

# Gunite Automatic Slack Adjuster

## Product Catalog and Cross Reference



Assembled in the USA



Your only single source for industry-leading wheel end solutions.  
STEEL & ALUMINUM WHEELS | DRUMS | HUBS | ROTORS | SLACK ADJUSTERS



## Gunite Automatic Slack Adjuster Identification

With the launch of Gunite's new state-of-the-art automatic slack adjuster assembly line there has been a change to the identification information formatting. The identification information now includes the part number, date code and serial number (TYPE II). The identification information is located on the end cap facing the brake chamber. Please reference the below illustrations for the identification information and formatting.

### Automatic Slack Adjuster Data Code Illustration

#### Type I

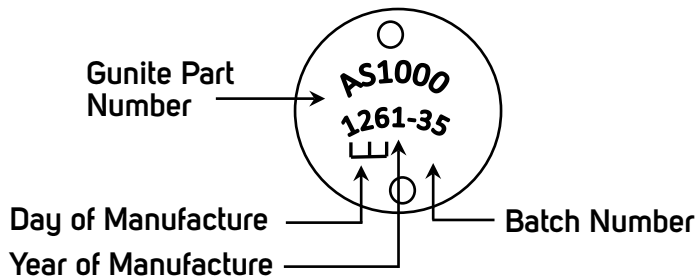

#### Type II

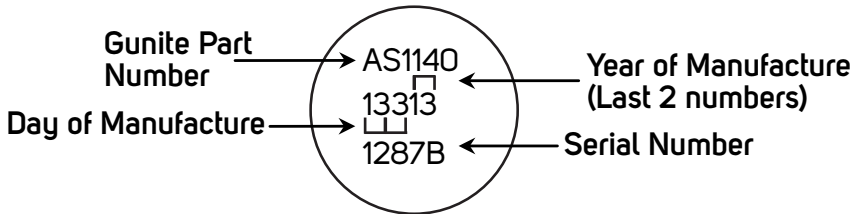

Please continue to supply the part number and date code information on all warranty claims as has been done in the past. For further information, contact Gunite Field Engineering at (800) 677-3786.

# TABLE OF CONTENTS

Identification.....	Inside Cover
Table of Contents.....	1
Warranty.....	2-3
Features and Benefits	
Automatic Slack Adjusters	
Other Brands Comparison.....	2
Numerical Listing	
Automatic Slack Adjusters.....	3
Clevis Kits.....	4
Service Kits.....	4
Axle Applications	
Front (Steer) Axle Applications.....	5
Rear (Drive) Axle Applications.....	5
Trailer Axle Applications.....	5
Obsolete Products	
Obsolescence Listing.....	6
Cross References	
Gunite Production to Gunite Aftermarket.....	7-10
OEM Part Number to Gunite.....	11-15
Other Brands to Gunite	
Bendix Corporation.....	16-19
Crewson Industries.....	19-21
Eagle.....	21-22
Dana/Eaton Corporation.....	22-25
Euclid.....	25-29
Haldex Brake Systems.....	29-34
Meritor.....	34-41
Haldex Brake Systems – Midland.....	41-44
Sloan.....	44

The Gunite® part numbering system is proprietary to Gunite Corporation. Any improper or unauthorized use of these numbering systems, including adoption or use of any Gunite part number, even where the subject is one of modification or addition, is strictly prohibited and will be prosecuted by Gunite Corporation as a violation of U. S. and foreign copyright, trademark, and unfair competition laws. In addition, use of any Gunite trademark, trade name, packaging scheme, system, color, or design is likewise considered a violation of the trademark, trade name, and trade identity rights of Gunite Corporation.

The interchange information shown in this catalog is based on the best available information at the time of publication. Although reasonable care has been taken to ensure the accuracy of this information, Gunite Corporation does not assume any liability for errors, changes, omissions, or harm resulting from the use of this information. It is recommended that all parts be thoroughly checked to ensure proper fit, form, and function prior to installation.



## ACCURIDE WHEEL END SOLUTIONS (AWES) LIMITED WARRANTY TO FILE A WARRANTY CLAIM, CALL (800) 869-2275 ext 1

Accuride Wheels and Wheel End Solutions (AWES) warrants to the original purchaser or the original end user that its products are free from defects in material and workmanship. The limited warranty time-frame (reference table below) is based on the date of product manufacture and shall be void if the product is altered, modified, misapplied, misused, neglected, repaired or not maintained in accordance with the instructions printed in the product-specific Accuride's Safety & Service Manuals<sup>(2)</sup>.

### GENERAL PRODUCT OVERVIEW

Product Type	8 years/ 96 months	5 years/ 60 months	2 years/ 200,000 miles <sup>(1)</sup>	1 year/ 12 months
Accuride Aluminum Wheels <sup>(2)</sup>		Industry Standard Aluminum Wheels Duplex <sup>®</sup> Aluminum Wheels ACCU-SHIELD <sup>®</sup> Wheels ACCU-ARMOR <sup>™</sup> Wheels	Flange Wear on ACCU-FLANGE <sup>™</sup> Wheels	
Accuride Steel Wheels <sup>(2)</sup>	EverSteel <sup>®</sup> <sup>(7)</sup> Corrosion Only <sup>(6)</sup>	Extra Service Wheels <sup>™</sup> (ESW) Styled Steel Wheels Tubeless Wheels and Demountable Rims Steel Armor <sup>™</sup> <sup>(6)</sup>		ProFinish <sup>™</sup> Corrosion Only <sup>(6)</sup> Duplex <sup>®</sup> Steel Disc Wheels Duplex <sup>®</sup> Demountable Rims Tube-Type Wheels & Demountable Rims Light Truck Wheels Steel Bolt-Together Specialty Wheels

Product Type	6 years/ 1,000,000 miles <sup>(1)</sup>	5 years/ 500,000 miles <sup>(1)</sup>	4 years/ 400,000 miles <sup>(1)</sup>	3 years/ 350,000 miles <sup>(1)</sup>	3 years/ 300,000 miles <sup>(1)</sup>	2 years/ 200,000 miles <sup>(1)</sup>	Limited Warranty <sup>(2)</sup>
Gunite Slack Adjusters <sup>(2)</sup>	Over-The-Road/Line Operated Trucks and Trailers <sup>(4)</sup>	Over-The Road/Line Operated Trucks and Trailers <sup>(3)</sup>	School Bus/City Delivery Vehicles <sup>(4)</sup>		School Bus/City Delivery Vehicles <sup>(3)</sup>  Severe Service: Garbage/Refuse Trucks, Fire Trucks, Logging, etc. <sup>(4)</sup>	Severe Service: Garbage/Refuse Trucks, Fire Trucks, Logging, etc. <sup>(3)</sup>	
Gunite Hubs <sup>(2)</sup>		TRU-SET <sup>®</sup> Trailer		TRU-SET <sup>®</sup> Front/ Steer TRU-SET <sup>®</sup> Rear/ Drive			Industry Standard Hubs
Gunite Brake Drums <sup>(2)</sup>							Industry Standard Brake Drums
Gunite Disc Brake Rotors <sup>(2)(5)</sup>							Industry Standard Disc Brake Rotors
Gunite Spoke Wheels <sup>(2)</sup>							Industry Standard Spoke Wheels

(1) Time or miles, whichever occurs first. Time is measured from date of manufacture.

(2) See Remedies and Limitations of Remedies and refer to appropriate Accuride guide for additional limited warranty condition details: Accuride Rim/Wheel Safety & Service Manual, Gunite Heavy-Duty Brake Drums, Gunite Automatic Slack Adjuster Service Manual, Gunite Disc Brake Rotors Maintenance Manual, and Gunite Disc Wheel Hubs, High-Performance Hubs, Spoke Wheels Maintenance & Installation Manual, and Steel Wheel Refinishing Criteria.

(3) Manufactured prior to April 6, 2015.

(4) Manufactured on or after April 6, 2015.

(5) Limited warranty for life of product.\*

\* "Life of product" means such period until the product has reached its maximum/minimum brake surface limitation. Product remains subject to the terms and conditions in this limited warranty, including the provisions on additional product warranty criteria and remedies and limitation of remedies.

(6) Designated steel wheels are covered by a limited warranty to be free of "rust damage" from the date of manufacture indicated on the wheel: ProFinish<sup>™</sup> for twelve (12) months, Steel Armor<sup>™</sup> for sixty (60) months and EverSteel<sup>®</sup> for ninety-six (96) months. Rust damage is defined as rust sufficient to require refinishing as determined by Accuride in accordance with the most current version of Accuride's technical bulletin W2.043 Steel Wheel Refinishing Criteria. The Steel Armor<sup>™</sup> and EverSteel<sup>®</sup> Warranties do not cover, and expressly exclude, rust in the crevice between the disc and the rim. The Steel Armor<sup>™</sup> and EverSteel<sup>®</sup> coating limited warranties herein apply to wheels manufactured by Accuride on or after January 1, 2017. EverSteel<sup>®</sup> wheels manufactured before January 1, 2017 may be covered by a prior sixty (60) month warranty which is not changed by this update.

(7) Limited Availability.



## **ACCURIDE WHEEL END SOLUTIONS (AWES) LIMITED WARRANTY TO FILE A WARRANTY CLAIM, CALL (800) 869-2275 ext 1**

### **ADDITIONAL PRODUCT SPECIFIC LIMITED WARRANTY CRITERIA**

**Wheels and Rims:** The warranty shall be void if the product is used with improper tire sizes, inflation pressures, or exceeded load ratings. The warranty shall be void if the product is not properly maintained in accordance with the Accuride Rim/Wheel Safety & Service Manual. The warranty does not cover defects resulting from corrosion except as stated elsewhere in this document, other non-Accuride components, accident, excessive speed or other abnormal or severe operating conditions.

**ACCU-ARMOR™, ACCU-SHIELD®, ACCU-FLANGE™, STEEL ARMOR™, PROFINISH™ and EVERSTEEL®:** Accuride does not cover the following conditions: (i) Any damage in the areas of the mounting surfaces, such as the area under the mounting nuts, the area in contact with hubs or drums and the area in contact with other wheels in dual position, (ii) Any damage due to cleaning, including damage from the use of abrasives, abrasive brushes, steel wool, scouring pads, strong chemicals or corrosion except as stated elsewhere in this document, and/or (iii) Any damage to the wheel finish due to wheel/tire assembly, removal, balancing weight, misuse, or chipping, whether by contact with road obstacles such as stones, gravel, curbs, barriers, signs, tire changing equipment or otherwise. ACCU-SHIELD® products are not covered for corrosion. ACCU-FLANGE® products, after washing, can have wheel polish or carnauba wax applied with a 100% cotton cloth. The STEEL ARMOR™ and EVERSTEEL® limited warranties are void with respect to, and expressly exclude, all wheels that have been refinished or refurbished and, for wheels used without an Accuride Wheel-Guard®, the disc face and any other areas impacted by this failure. The EVERSTEEL® limited warranty is void with respect to, and expressly excludes wheels that have had the serial number sticker removed or defaced. The STEEL ARMOR™, PROFINISH™, and EVERSTEEL® warranties expressly exclude and do not cover (a) paint appearance, paint integrity, or paint adhesion to the wheels due to chipping effect and (b) corrosion in the crevice between the wheel disc and rim. Accuride recommends cleaning wheels with mild soap and water.

**Standard Brake Drums, Spoke Wheels, Disc Wheel Hubs, Automatic Slack Adjusters, and Hardware:** The above warranty shall be void if (i) any goods have exceeded Accuride's acceptable wear limits or have been subjected to accidents or abnormal conditions of use, temperature, moisture, dirt or corrosive matter, or (ii) the product fails as the result of another manufacturer's product. The TRU-SET® disc wheel hub requires the use of a seller-approved hubcap and lubricant

### **REMEDIES AND LIMITATIONS OF REMEDIES**

In the event of any material breach of the above limited warranties, Accuride agrees to repair or replace,\* at its sole option, without charge any and all of its warrantable product that fail during normal use and service due to defects in material and/or workmanship, all subject to the original purchaser providing written notice of the alleged breach within 30 days of failure. Time is of the essence herein, and original purchaser's failure to provide written notice to Accuride within the required time of any alleged breach of the foregoing warranty will release and discharge Accuride from any obligation or liability for that breach of warranty. In no event will Accuride be liable for any other costs associated with the replacement or repair of product covered under this warranty, including labor, installation or other costs incurred by customer.

\* - NOTWITHSTANDING THE ABOVE, THE SOLE REMEDY UNDER THE STEEL ARMOR™ AND EVERSTEEL® WARRANTIES SHALL BE THE PAYMENT OF US \$35 FOR STEEL ARMOR™ AND US \$45 FOR EVERSTEEL® OR THE REPAIR OR REPLACEMENT OF THE WHEEL (AT ACCURIDE'S SOLE OPTION) IF A WARRANTABLE PRODUCT FAILS DURING NORMAL USE AND SERVICE DUE TO DEFECTS IN MATERIAL AND/OR WORKMANSHIP. Only one claim per wheel may be paid under the Steel Armor™ and EverSteel® warranties. The remedy described in this paragraph is Accuride's sole and exclusive obligation under these warranties and in no event will Accuride be liable for special, incidental or consequential damages.

Customer must timely report the breach of warranty and demonstrate warrantability under the then applicable procedures during the warranty period. The remedies set forth herein shall be the sole and exclusive remedies available to the original purchaser so that Accuride repair, replacement, or payment as described above is a fulfillment of all Accuride obligations. Accuride SHALL NOT BE LIABLE FOR ANY CONSEQUENTIAL OR INCIDENTAL DAMAGES OF ANY KIND. FURTHER, UNDER NO CIRCUMSTANCE SHALL ACCURIDE BE LIABLE FOR DAMAGES BEYOND THE PRICE OF THE GOODS PURCHASED BY THE ORIGINAL PURCHASER, WHETHER IN CONTRACT, IN TORT OR UNDER ANY WARRANTY OR OTHER USE.

Accuride reserves the right to require product return and/or washing (as previously noted) prior to warranty assessment as a condition of eligibility for warranty remedies. Product return expense must be paid by the product owner and if the product is found warrantable, reasonable freight expenses may be reimbursed by Accuride. No goods are to be returned to Accuride without a Returned Goods Authorization (RGA). If Accuride determines that any of the returned goods are non-warrantable, Accuride reserves the right to charge the original purchaser for the recovery of all transportation costs and expenses incurred in examining, processing and handling such goods. Any controversy or claim that customer may wish to bring that is arising out of or related to this limited warranty or breach hereof must be commenced in writing within 30 days of notification of warrantable status or shall be deemed to be waived.

Any product deemed non-warrantable is the property of the original purchaser and can be returned to the original purchaser upon its request and at its sole cost and expense. Should the non-warrantable item(s) not be reclaimed, Accuride will disposition the product no sooner than 30 days after original purchaser notification has been made.

For all warranty related questions, please contact your Accuride warranty administrator at (800) 869-2275 Option 1 or submit questions or claims to [warrantyadmin@accuridecorp.com](mailto:warrantyadmin@accuridecorp.com).

THE ABOVE WARRANTY IS THE SOLE AND EXCLUSIVE WARRANTY GIVEN BY ACCURIDE AND IS IN LIEU OF ALL OTHER WARRANTIES EXPRESSED, STATUTORY OR IMPLIED, INCLUDING WARRANTIES OF MERCHANTABILITY AND FITNESS FOR A PARTICULAR PURPOSE, ALL OF WHICH ARE EXPRESSLY DISCLAIMED BY ACCURIDE. IN NO EVENT SHALL THIS WARRANTY BE DEEMED TO COVER INCIDENTAL, SPECIAL, INDIRECT OR CONSEQUENTIAL DAMAGES OF ANY KIND.

## FEATURES AND BENEFITS

Gunite slack adjusters are proven, year after year, as the standard of the industry in providing superior performance, reduced maintenance costs and consistent, long-term reliability, trip after trip. You can depend on Gunite quality.

- 5", 5-1/2", 6", 6-1/2" Arm Lengths
- Straight or Offset clevis with 1/2" or 5/8" threads
- Unhanded design
- Compact housing for easy installation
- Drilled worm wheel
- Factory lubricated and sealed
- Extended life clevis pin bushing
- O-Ring on spline gear
- Available in 10, 24, 28, or 37 spline configurations
- Threaded and welded clevis applications



### FEATURES AND BENEFITS

Feature	Gunite	Meritor	Bendix	Stemco Crewson	Haldex
Sensing Type	Clearance	Stroke	Clearance	Clearance	Clearance
Clutch	Cone Clutch	Ratcheting	Torsion Spring	Cone Clutch	Cone Clutch
Clutch Spring	Belleville Springs	No Spring	Torsion Spring	Coil	Coil
Adjustment Occurs	On Apply	On Return	On Apply	On Return	On Return
Drilled Gear	Drilled	Drilled	Optional	Drilled	No
Gear Thread	Buttress	Buttress	Symmetric	Symmetric	Buttress
Non-Handed	Yes	No	Yes	Yes	Yes
External Attachments	No	No	No	No	Yes
SLIC Pin	Yes	No	No	No	No

Features and Benefits

Numerical Listings

Axle Applications

Obsolete Products

Cross References



## NUMERICAL LISTING

### GUNITE AUTOMATIC SLACK ADJUSTER KITS

Gunite P/N	Packaged Weight	Arm Length	Number of Splines	Splines Diameter	Clevis Kit
		A	B	C	D
AS1131	8.0	5"	10	1-1/2"	AS3016
AS1132	8.0	5-1/2"	10	1-1/2"	AS3019
AS1133	8.0	6"	10	1-1/2"	AS3016
AS1134	8.0	6-1/2"	10	1-1/2"	AS3016
AS1135	8.0	5"	10	1-1/4"	AS3019
AS1136	8.0	5-1/2"	10	1-1/4"	AS3019
AS1137	8.0	5"	24	1-1/4"	AS3019
AS1138	8.0	5-1/2"	24	1-1/4"	AS3019
AS1139	8.0	5"	28	1-1/2"	AS3016
AS1140	8.0	5-1/2"	28	1-1/2"	AS3019
AS1141	8.0	6"	28	1-1/2"	AS3016
AS1142	8.0	6-1/2"	28	1-1/2"	AS3016
AS1143 <sup>(1)</sup>	8.0	5-1/2"	37	1-5/8"	AS3018
AS1144 <sup>(1)</sup>	8.0	6"	37	1-5/8"	AS3018
AS1145 <sup>(1)</sup>	8.0	6-1/2"	37	1-5/8"	AS3018
AS1146 <sup>(1)</sup>	8.0	5-1/2"	10	1-1/2"	AS3018
AS1147 <sup>(1)</sup>	8.0	6"	10	1-1/2"	AS3018
AS1148 <sup>(1)</sup>	8.0	6-1/2"	10	1-1/2"	AS3018
AS1149 <sup>(1)</sup>	8.0	5-1/2"	28	1-1/2"	AS3018
AS1150 <sup>(1)</sup>	8.0	6"	28	1-1/2"	AS3018
AS1151 <sup>(1)</sup>	8.0	6-1/2"	28	1-1/2"	AS3018
AS1152 <sup>(2)</sup>	8.0	5-1/2"	10	1-1/4"	AS3002
AS1153 <sup>(3)</sup>	8.0	5-1/2"	10	1-1/4"	AS3003
AS1154 <sup>(2)</sup>	8.0	5-1/2"	24	1-1/4"	AS3002
AS1155 <sup>(3)</sup>	8.0	5-1/2"	24	1-1/4"	AS3003
AS1156 <sup>(3)</sup>	8.0	5-1/2"	10	1-1/2"	AS3003
AS1157 <sup>(3)</sup>	8.0	5-1/2"	28	1-1/2"	AS3003
AS1159 <sup>(4)</sup>	8.0	5-1/2"	37	1-5/8"	AS3021
AS1160 <sup>(4)</sup>	8.0	6"	37	1-5/8"	AS3021
AS1161 <sup>(4)</sup>	8.0	6-1/2"	37	1-5/8"	AS3021
AS1162 <sup>(4)</sup>	8.0	5-1/2"	10	1-1/2"	AS3021
AS1163 <sup>(4)</sup>	8.0	6"	10	1-1/2"	AS3021
AS1164 <sup>(4)</sup>	8.0	6-1/2"	10	1-1/2"	AS3021
AS1165 <sup>(4)</sup>	8.0	5-1/2"	28	1-1/2"	AS3021
AS1166 <sup>(4)</sup>	8.0	6"	28	1-1/2"	AS3021
AS1167 <sup>(4)</sup>	8.0	6-1/2"	28	1-1/2"	AS3021

Above referenced Automatic Slack Adjuster Kits are furnished with a Clevis that has a 1.02" pin center distance.

<sup>(1)</sup> Extended length Clevis included for trailer applications.

<sup>(2)</sup> .625" offset, 1/2" - 20 thread Clevis.

<sup>(3)</sup> .625" offset, 5/8" - 18 thread Clevis.

<sup>(4)</sup> Extended length collar lock Clevis with stainless steel pins.

### GUNITE 2000 AUTOMATIC SLACK ADJUSTERS

Gunite P/N	Packaged Weight	Arm Length	Number of Splines	Splines Diameter	Clevis Kit
		A	B	C	D
AS1168	8.0	5-1/2"	10	1-1/2"	n/a
AS1169	8.0	6"	10	1-1/2"	n/a
AS1170	8.0	5-1/2"	10	1-1/4"	n/a
AS1171	8.0	5-1/2"	24	1-1/4"	n/a
AS1172	8.0	5-1/2"	28	1-1/2"	n/a
AS1173	8.0	6"	28	1-1/2"	n/a
AS1174	8.0	6-1/2"	10	1-1/2"	n/a
AS1175	8.0	6-1/2"	28	1-1/2"	n/a
AS2168 <sup>(1)</sup>	8.0	5-1/2"	10	1-1/2"	n/a
AS2169 <sup>(1)</sup>	8.0	6"	10	1-1/2"	n/a
AS2170 <sup>(1)</sup>	8.0	5-1/2"	10	1-1/4"	n/a
AS2171 <sup>(1)</sup>	8.0	5-1/2"	24	1-1/4"	n/a
AS2172 <sup>(1)</sup>	8.0	5-1/2"	28	1-1/2"	n/a
AS2173 <sup>(1)</sup>	8.0	6"	28	1-1/2"	n/a
AS2174 <sup>(1)</sup>	8.0	6-1/2"	10	1-1/2"	n/a
AS2175 <sup>(1)</sup>	8.0	6-1/2"	28	1-1/2"	n/a

Above referenced Automatic Slack Adjusters require the use of a Clevis with a 1.3" pin center distance. **DO NOT** attempt to install a Gunite 2000 Automatic Slack Adjuster using a Gunite standard (1.02" pin center distance) collar lock or threaded clevis kit, as this will cause improper brake function.

<sup>(1)</sup>The Enhanced Gunite 2000 design can be installed on a range of OEM applications currently in use today. It is recommended for use with vehicles manufactured after Phase I RSD requirements took effect in August 2011.

**VMRS**  
**#13-001-030 (Front Axles)**  
**#13-002-0028 (Rear Axles)**

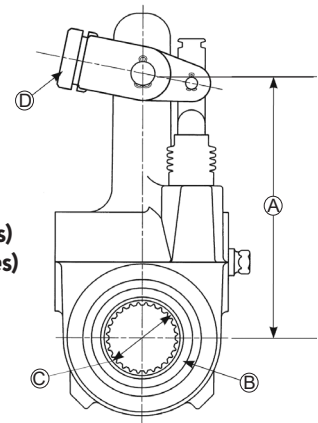

# NUMERICAL LISTING

## VMRS #13-002-056 (Clevis)



Standard Length Threaded



Standard Length Collar Lock



Standard Length Threaded, Offset



Extended Length Threaded



Extended Length Collar Lock

### CLEVIS KITS - D

Gunite P/N	Packaged Weight	Clevis Type	Style	Push Rod Thread	Special Notes
AS3000	0.8	Threaded	Straight	5/8-18"	
AS3001	0.8	Threaded	Straight	1/2-20"	
AS3002	0.9	Threaded	5/8" Offset	1/2-20"	
AS3003	0.9	Threaded	5/8" Offset	5/8-18"	
AS3011 <sup>(5)</sup>	0.8	Threaded	Straight	5/8-18"	For applications with 5/8" Clevis Pins
AS3012 <sup>(5)</sup>	0.8	Threaded	Straight	1/2-20"	For applications with 5/8" Clevis Pins
AS3013	1.0	Extended Threaded	Straight	5/8-18"	
AS3015	1.0	Extended Threaded	Straight	5/8-18"	Furnished with Stainless Steel Clevis Pins
AS3016	0.8	Collar Lock	Straight	5/8-18"	
AS3017	0.9	Collar Lock	Straight	1/2-20"	
AS3018	0.9	Extended Collar Lock	Straight	5/8-18"	
AS3019	1.0	Collar Lock	Straight	1/2-20" & 5/8-18"	Furnished with (1) 1/2" and (1) 5/8" Collar Nuts
AS3021	0.9	Extended Collar Lock	Straight	5/8-18"	With Stainless Steel Clevis Pins

Above referenced Automatic Slack Adjusters Kits are furnished with a Clevis that has a 1.02" pin center distance. When installing or replacing a Gunite Automatic Slack Adjuster, it is recommended that a new clevis assembly be installed in accordance with the Gunite Automatic Slack Adjuster Service manual.



1/4" SLIC Pin



1/2" SLIC Pin

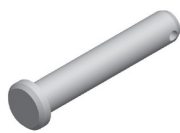

1/4" Clevis Pin

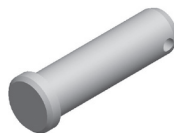

1/2" Clevis Pin



Cotter Pin

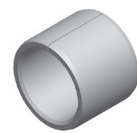

Arm Bushing

### SERVICE KITS

Gunite P/N	Packaged Weight	Description	Contents	Special Notes
AS4004	0.8	Clevis Pin Kit	(6) 1/2" Clevis Pins, (6) 1/4" Clevis Pins, (12) Cotter Pins	
AS4008	0.7	Installation Gauge	OEM Installation Gauge	
AS4012	0.9	Stainless Steel Clevis Pin Kit	(6) 1/2" Clevis Pins, (6) 1/4" Clevis Pins, (12) Cotter Pins	Stainless Steel Components
AS4013	0.5	Collar Lock Nuts	(4) 1-1/4" Locking Nuts, (4) 5/8"-18 Collar Nuts	
AS4014	0.5	Collar Lock Nuts	(4) 1-1/4" Locking Nuts, (4) 1/2"-20 Collar Nuts	
AS4015	0.4	Arm Bushing Kit	(24) 1/2" Steel Arm Bushings	
AS4650	0.7	Template	(50) Per Package	For Standard Slack Adjuster

NOTE: (#) equals quantity.



## AXLE APPLICATION

### FRONT (STEER) AXLE APPLICATIONS

Gunitite P/N	Packaged Weight	Arm Length		Splines Diameter	Clevis Kit
		A	B		
AS1135	8.0	5"	10	1-1/4"	AS3019
AS1136	8.0	5-1/2"	10	1-1/4"	AS3019
AS1152 <sup>(6)</sup>	8.0	5-1/2"	10	1-1/4"	AS3002
AS1153 <sup>(7)</sup>	8.0	5-1/2"	10	1-1/4"	AS3003
AS1170	8.0	5-1/2"	10	1-1/4"	n/a
AS2170	8.0	5-1/2"	10	1-1/4"	n/a
AS1132	8.0	5-1/2"	10	1-1/2"	AS3019
AS1168	8.0	5-1/2"	10	1-1/2"	n/a
AS2168	8.0	5-1/2"	10	1-1/2"	n/a
AS1137	8.0	5"	24	1-1/4"	AS3019
AS1138	8.0	5-1/2"	24	1-1/4"	AS3019
AS1154 <sup>(6)</sup>	8.0	5-1/2"	24	1-1/4"	AS3002
AS1155 <sup>(7)</sup>	8.0	5-1/2"	24	1-1/4"	AS3003
AS1171	8.0	5-1/2"	24	1-1/4"	n/a
AS2171	8.0	5-1/2"	24	1-1/4"	n/a
AS1140	8.0	5-1/2"	28	1-1/2"	AS3019
AS1172	8.0	5-1/2"	28	1-1/2"	n/a
AS2172	8.0	5-1/2"	28	1-1/2"	n/a

### REAR (DRIVE) AXLE APPLICATIONS

Gunitite P/N	Packaged Weight	Arm Length		Splines Diameter	Clevis Kit
		A	B		
AS1131	8.0	5"	10	1-1/2"	AS3016
AS1132	8.0	5-1/2"	10	1-1/2"	AS3019
AS1156 <sup>(7)</sup>	8.0	5-1/2"	10	1-1/2"	AS3003
AS1168	8.0	5-1/2"	10	1-1/2"	n/a
AS2168	8.0	5-1/2"	10	1-1/2"	n/a
AS1133	8.0	6"	10	1-1/2"	AS3016
AS1169	8.0	6"	10	1-1/2"	n/a
AS2169	8.0	6"	10	1-1/2"	n/a
AS1134	8.0	6-1/2"	10	1-1/2"	AS3016
AS1174	8.0	6-1/2"	10	1-1/2"	n/a
AS2174	8.0	6-1/2"	10	1-1/2"	n/a
AS1139	8.0	5"	28	1-1/2"	AS3016
AS1140	8.0	5-1/2"	28	1-1/2"	AS3019
AS1157 <sup>(7)</sup>	8.0	5-1/2"	28	1-1/2"	AS3003
AS1172	8.0	5-1/2"	28	1-1/2"	n/a
AS2172	8.0	5-1/2"	28	1-1/2"	n/a
AS1141	8.0	6"	28	1-1/2"	AS3016
AS1173	8.0	6"	28	1-1/2"	n/a
AS2173	8.0	6"	28	1-1/2"	n/a
AS1142	8.0	6-1/2"	28	1-1/2"	AS3016
AS1175	8.0	6-1/2"	28	1-1/2"	n/a
AS2175	8.0	6-1/2"	28	1-1/2"	n/a

### TRAILER AXLE APPLICATIONS

Gunitite P/N	Packaged Weight	Arm Length		Splines Diameter	Clevis Kit
		A	B		
AS1146	8.0	5-1/2"	10	1-1/2"	AS3018
AS1162 <sup>(6)</sup>	8.0	5-1/2"	10	1-1/2"	AS3021
AS1168	8.0	5-1/2"	10	1-1/2"	n/a
AS2168	8.0	5-1/2"	10	1-1/2"	n/a
AS1147	8.0	6"	10	1-1/2"	AS3018
AS1163 <sup>(6)</sup>	8.0	6"	10	1-1/2"	AS3021
AS1169	8.0	6"	10	1-1/2"	n/a
AS2169	8.0	6"	10	1-1/2"	n/a
AS1148	8.0	6-1/2"	10	1-1/2"	AS3018
AS1164 <sup>(6)</sup>	8.0	6-1/2"	10	1-1/2"	AS3021
AS1174	8.0	6-1/2"	10	1-1/2"	n/a
AS1149	8.0	5-1/2"	28	1-1/2"	AS3018
AS1165 <sup>(6)</sup>	8.0	5-1/2"	28	1-1/2"	AS3021
AS1172	8.0	5-1/2"	28	1-1/2"	n/a
AS2172	8.0	5-1/2"	28	1-1/2"	n/a
AS1150	8.0	6"	28	1-1/2"	AS3018
AS1166 <sup>(6)</sup>	8.0	6"	28	1-1/2"	AS3021
AS1173	8.0	6"	28	1-1/2"	n/a
AS2173	8.0	6"	28	1-1/2"	n/a
AS1151	8.0	6-1/2"	28	1-1/2"	AS3018
AS1167 <sup>(6)</sup>	8.0	6-1/2"	28	1-1/2"	AS3021
AS1175	8.0	6-1/2"	28	1-1/2"	n/a
AS2175	8.0	6-1/2"	28	1-1/2"	n/a
AS1143	8.0	5-1/2"	37	1-5/8"	AS3018
AS1159 <sup>(6)</sup>	8.0	5-1/2"	37	1-5/8"	AS3021
AS1144	8.0	6"	37	1-5/8"	AS3018
AS1160 <sup>(6)</sup>	8.0	6"	37	1-5/8"	AS3021
AS1145	8.0	6-1/2"	37	1-5/8"	AS3018
AS1161 <sup>(6)</sup>	8.0	6-1/2"	37	1-5/8"	AS3021

<sup>(6)</sup> .625" offset, 1/2" - 20 thread Clevis.

<sup>(7)</sup> .625" offset, 5/8" - 18 thread Clevis.

<sup>(8)</sup> Extended length collar lock Clevis with stainless steel pins.

## OBSOLETE PRODUCTS

### GUNITE PART NUMBER – WITH CLEVIS KIT INCLUDED

Obsolete Service Number	Gunite P/N-Direct Replacement	No Offset Front (Steer) Axles	.625" Offset Front (Steer) Axles		Rear (Drive) Axles	.625" Offset Rear (Drive) Axles	Trailer Axles
		Front (Steer) Axle Applications	.500-20 Thread	.625-18 Thread			
AS1000	AS1133				AS1133		AS1147
AS1001	AS1141				AS1141		AS1150
AS1002	AS1144						AS1144
AS1005	AS1136	AS1136	AS1152	AS1153			
AS1007	AS1138	AS1138	AS1154	AS1155			
AS1011	AS1138	AS1138	AS1154	AS1155			
AS1012	AS1140	AS1140			AS1140	AS1157	AS1149
AS1013	AS1135	AS1135					
AS1014	AS1131				AS1131		
AS1015	AS1137	AS1137					
AS1016	AS1139				AS1139		
AS1017	AS1137	AS1137					
AS1018	AS1139				AS1139		
AS1019	AS1132	AS1132			AS1132	AS1156	AS1146
AS1020	AS1140	AS1140			AS1140	AS1157	AS1149
AS1021	AS1143						AS1143
AS1025	AS1134				AS1134		AS1148
AS1026	AS1142				AS1142		AS1151
AS1031	AS1131				AS1131		
AS1032	AS1132	AS1132			AS1132	AS1156	AS1146
AS1033	AS1133				AS1133		AS1147
AS1034	AS1134				AS1134		AS1148
AS1035	AS1135	AS1135					
AS1036	AS1136	AS1136	AS1152	AS1153			
AS1037	AS1137	AS1137					
AS1038	AS1138	AS1138	AS1154	AS1155			
AS1039	AS1139				AS1139		
AS1040	AS1140	AS1140			AS1140	AS1157	AS1149
AS1041	AS1141				AS1141		AS1150
AS1042	AS1142				AS1142		AS1151
AS1043	AS1143						AS1143
AS1044	AS1144						AS1144



## CROSS REFERENCES

### GUNITE PRODUCTION TO GUNITE AFTERMARKET

Gunite Production P/N	Gunite Aftermarket P/N	Gunite Clevis Kit P/N	Gunite Production P/N	Gunite Aftermarket P/N	Gunite Clevis Kit P/N	Gunite Production P/N	Gunite Aftermarket P/N	Gunite Clevis Kit P/N
00-20125	AS1040 <sup>(9)</sup>		550010	AS1036		SA00501	AS1040	AS3000
00-20125	AS1042 <sup>(10)</sup>		556510	AS1032 <sup>(9)</sup>		SA00502	AS1041	AS3000
00-20126	AS1032 <sup>(9)</sup>		556510	AS1034 <sup>(10)</sup>		SA00503	AS1042	AS3000
00-20126	AS1034 <sup>(10)</sup>		556528	AS1040 <sup>(9)</sup>		SA00601	AS1043	AS3000
98-20010	AS3000		556528	AS1042 <sup>(10)</sup>		SA00602	AS1044	AS3000
98-20072	AS3003		600010	AS1033		SA00603	AS1045	AS3000
98-20074	AS3002		600028	AS1041		SA00701		AS3000
98-20076	AS3001		600037	AS1044		SA00702		AS3001
ACF4205-1	AS1044		10345901	AS1033		SA00703		AS3003
APA0994-2	AS1040 <sup>(9)</sup>		10345902	AS1041		SA00704		AS3002
APA0994-2	AS1042 <sup>(10)</sup>		10345903	AS1044		SA00801	AS1033	AS3000
D00-20002	AS1041		10345904	AS1032 <sup>(9)</sup>		SA00802	AS1032 <sup>(9)</sup>	AS3000
D00-20003	AS1044		10345904	AS1034 <sup>(10)</sup>		SA00802	AS1034 <sup>(10)</sup>	AS3000
D00-20011	AS1040 <sup>(9)</sup>		10345905	AS1040 <sup>(9)</sup>		SA00803	AS1156	
D00-20011	AS1042 <sup>(10)</sup>		10345905	AS1042 <sup>(10)</sup>		SA00804	AS1036	AS3000
D00-20080	AS1036		10345906	AS1043 <sup>(9)</sup>		SA00805	AS1032	AS3000
KN5220	AS1044		10345906	AS1045 <sup>(10)</sup>		SA00806	AS1034	AS3000
KN52200	AS1033		10345907	AS1032 <sup>(9)</sup>		SA00807	AS1152	
KN52210	AS1041		10345907	AS1034 <sup>(10)</sup>		SA00808	AS1153	
KN52230	AS1032 <sup>(9)</sup>		10345908	AS1040 <sup>(9)</sup>		SA00901	AS1041	AS3000
KN52230	AS1034 <sup>(10)</sup>		10345908	AS1042 <sup>(10)</sup>		SA00902	AS1040 <sup>(9)</sup>	AS3000
KN52240	AS1040 <sup>(9)</sup>		10345909	AS1043 <sup>(9)</sup>		SA00902	AS1042 <sup>(10)</sup>	AS3000
KN52240	AS1042 <sup>(10)</sup>		10345909	AS1045 <sup>(10)</sup>		SA00903	AS1040	AS3000
KN52260	AS1043 <sup>(9)</sup>		10345910	AS1032 <sup>(9)</sup>		SA00904	AS1042	AS3000
KN52260	AS1045 <sup>(10)</sup>		10345910	AS1034 <sup>(10)</sup>		SA00905	AS1040	AS3003
SA00101	AS1033		10345911	AS1040 <sup>(9)</sup>		SA00906	AS1040	AS3001
SA00102	AS1032		10345911	AS1042 <sup>(10)</sup>		SA00907	AS1041	AS3021
SA00103	AS1034		10345912	AS1036		SA00908	AS1040	AS3021
SA00104	AS1032 <sup>(9)</sup>		10480401	AS1033		SA01001	AS1044	AS3000
SA00104	AS1034 <sup>(10)</sup>		10480501	AS1041		SA01002	AS1043	AS3000
SA00105	AS1036		10480601	AS1044		SA01003	AS1045	AS3000
SA00106	AS1035		10480701	AS1032 <sup>(9)</sup>		SA01101	AS1032	AS3000
SA00107	AS1031		10480701	AS1034 <sup>(10)</sup>		SA01102	AS1033	AS3000
SA00201	AS1041		10480801	AS1040 <sup>(9)</sup>		SA01103	AS1034	AS3000
SA00202	AS1040		10480801	AS1042 <sup>(10)</sup>		SA01201	AS1040	AS3000
SA00203	AS1042		10480901	AS3000		SA01202	AS1041	AS3000
SA00204	AS1040 <sup>(9)</sup>		10481001	AS3003		SA01203	AS1042	AS3000
SA00204	AS1042 <sup>(10)</sup>		10661701	AS3002		SA01204	AS1040	AS3000
SA00205	AS1039		10661901	AS3001		SA01301	AS1043	AS3000
SA00206	AS1039		00-20105	AS1040 <sup>(9)</sup>		SA01302	AS1044	AS3000
SA00301	AS1044		00-20105	AS1042 <sup>(10)</sup>		SA01303	AS1045	AS3000
SA00302	AS1043		00-20106	AS1032 <sup>(9)</sup>		SA01304	AS1044	AS3000
SA00303	AS1045		00-20106	AS1034 <sup>(10)</sup>		SA01401		AS3000
SA00304	AS1043 <sup>(9)</sup>		00-20115	AS1041		SA01501		AS3003
SA00304	AS1045 <sup>(10)</sup>		00-20116	AS1033		SA01601		AS3002
SA00401	AS1032	AS3000	00-20124	AS1043 <sup>(9)</sup>		SA01701		AS3001
SA00402	AS1033	AS3000	00-20124	AS1045 <sup>(10)</sup>		SA01901	AS1040	AS3000
SA00403	AS1034							

<sup>(9)</sup> For 5.5" arm lengths only.

<sup>(10)</sup> For 6.5" arm lengths only.

# CROSS REFERENCES

## GUNITE PRODUCTION TO GUNITE AFTERMARKET

Gunite Production P/N	Gunite Aftermarket P/N	Gunite Clevis Kit P/N	Gunite Production P/N	Gunite Aftermarket P/N	Gunite Clevis Kit P/N	Gunite Production P/N	Gunite Aftermarket P/N	Gunite Clevis Kit P/N
SA02001	AS1044	AS3000	SA03102	AS1137		SA05703	AS1034	AS3018
SA02101	AS1133		SA03103	AS1038	AS3000	SA05704	AS1163	
SA02104	AS1132		SA03112	AS1155		SA05801	AS1140	AS3018
SA02105	AS1134		SA03113	AS1155		SA05802	AS1041	AS3018
SA02106	AS1131		SA03114	AS1038	AS3003	SA05803	AS1042	AS3018
SA02110	AS1156		SA03301	AS1038		SA05804	AS1040	AS3021
SA02111	AS1156		SA03401	AS1138		SA05805	AS1166	
SA02112	AS1031	AS3002	SA03501	AS1040		SA05901	AS1143	
SA02113	AS1031	AS3002	SA03601	AS1140		SA05902	AS1144	
SA02114	AS1033	AS3003	SA03602	AS1141		SA05903	AS1145	
SA02115	AS1033	AS3003	SA04101	AS1138		SA06001		AS3013
SA02201	AS1141		SA04103	AS1137		SA06002		AS3015
SA02203	AS1140		SA04201	AS1140		SA06201	AS1036	AS3018
SA02204	AS1142		SA04202	AS1141		SA06401	AS1131	
SA02205	AS1139		SA04203	AS1139		SA06402	AS1132	
SA02206	AS1041	AS3021	SA04301	AS1038		SA06403	AS1133	
SA02207	AS1040	AS3021	SA04331	AS4001		SA06404	AS1134	
SA02210	AS1041	AS3003	SA04332	AS4007		SA06502	AS1146	
SA02211	AS1041	AS3003	SA04333	AS4007		SA06503	AS1033	AS3018
SA02212	AS1157		SA04401	AS1040		SA06504	AS1034	AS3018
SA02213	AS1157		SA04431	AS4015		SA06513	AS1163	
SA02301	AS1044	AS3019	SA04432	AS4005		SA06601	AS1135	
SA02302	AS1043	AS3019	SA04532	AS4006		SA06602	AS1136	
SA02303	AS1045	AS3019	SA04632	AS4008		SA06702	AS1036	AS3018
SA02304	AS1043	AS3019	SA04701	AS1037		SA06801	AS1137	
SA02304	AS1045	AS3019	SA04702	AS1038		SA06802	AS1138	
SA02401	AS1132		SA04801	AS1039		SA06901	AS1137	
SA02402	AS1133		SA04802	AS1040		SA06902	AS1138	
SA02403	AS1134		SA04803	AS1041		SA07001	AS1139	
SA02501	AS1140		SA04901	AS4004		SA07002	AS1140	
SA02502	AS1141		SA04902	AS4006		SA07003	AS1141	
SA02503	AS1142		SA05301	AS1038	AS3000	SA07004	AS1142	
SA02601	AS1043	AS3019	SA05401	AS1032	AS3015	SA07012	AS1040	AS3021
SA02602	AS1044	AS3019	SA05402	AS1033	AS3015	SA07013	AS1041	AS3021
SA02603	AS1045	AS3019	SA05403	AS1034	AS3013	SA07101	AS1139	
SA02701	AS1136		SA05501	AS1040	AS3013	SA07102	AS1140	
SA02702	AS1135		SA05502	AS1041	AS3013	SA07103	AS1141	
SA02712	AS1153		SA05503	AS1042	AS3013	SA07202	AS1040	AS3018
SA02713	AS1153		SA05504	AS1040	AS3015	SA07203	AS1041	AS3018
SA02801		AS3000	SA05505	AS1041	AS3021	SA07204	AS1042	AS3018
SA02901		AS3001	SA05601	AS1043	AS3013	SA07212	AS1040	AS3021
SA03001	AS1038		SA05602	AS1044	AS3013	SA07213	AS1166	
SA03002	AS1037		SA05603	AS1045	AS3013	SA07302	AS1043	AS3019
SA03003	AS1037		SA05701	AS1146		SA07303	AS1044	AS3019
SA03101	AS1138		SA05702	AS1033	AS3018	SA07304	AS1045	AS3019

Replacement of other brands of stack adjusters should be done in axle sets. Industry Part Numbers referencing more than a single interchange is the result of Gunite offering the option of ordering its Automatic Slack Adjusters with or without the clevis kit.



## CROSS REFERENCES

### GUNITE PRODUCTION TO GUNITE AFTERMARKET

Gunite Production P/N	Gunite Aftermarket P/N	Gunite Clevis Kit P/N	Gunite Production P/N	Gunite Aftermarket P/N	Gunite Clevis Kit P/N	Gunite Production P/N	Gunite Aftermarket P/N	Gunite Clevis Kit P/N
SA07402	AS1143		SA09102	AS1032	AS3015	SA10803	AS1041	AS3018
SA07403	AS1144		SA09103	AS1033	AS3015	SA10804	AS1042	AS3018
SA07404	AS1145		SA09104	AS1034	AS3013	SA10812	AS1040	AS3015
SA07501		AS3016	SA09202	AS1040	AS3013	SA10813	AS1166	
SA07502		AS3017	SA09203	AS1041	AS3013	SA10902	AS1143	
SA07505		AS3019	SA09204	AS1042	AS3013	SA10903	AS1144	
SA07601		AS3018	SA09212	AS1040	AS3015	SA10904	AS1145	
SA07602		AS3015	SA09213	AS1041	AS3021	SA10913	AS1160	
SA07701	AS4013		SA09302	AS1043	AS3013	SA11001	AS1031	AS3018
SA07702	AS4014		SA09303	AS1044	AS3013	SA11002	AS1146	
SA07705	AS4013		SA09304	AS1045	AS3013	SA11003	AS1033	AS3018
SA07706	AS4014		SA09402	AS1152		SA11101	AS1039	AS3018
SA07801	AS1031		SA09502	AS1156		SA11102	AS1040	AS3018
SA07802	AS1032		SA09503	AS1033	AS3003	SA11103	AS1041	AS3018
SA07803	AS1033		SA09602	AS1153		SA11202	AS1132	
SA07804	AS1034		SA09702	AS1155		SA11203	AS1133	
SA07901	AS1035		SA09802	AS1040	AS3003	SA11302	AS1140	
SA07902	AS1036		SA09901	AS1131		SA11303	AS1141	
SA08001	AS1037		SA09902	AS1132		SA11402	AS1136	
SA08002	AS1038		SA09903	AS1133		SA11502	AS1138	
SA08101	AS1039		SA09904	AS1134		SA11602	AS1168	
SA08102	AS1040		SA10001	AS1135		SA11603	AS1169	
SA08103	AS1041		SA10002	AS1136		SA11604	AS1174	
SA08104	AS1042		SA10101	AS1137		SA11702	AS1170	
SA08202	AS1043		SA10102	AS1138		SA11802	AS1038	
SA08203	AS1044		SA10201	AS1139		SA11902	AS1172	
SA08204	AS1045		SA10202	AS1140		SA11903	AS1173	
SA08301	AS1037		SA10203	AS1141		SA11904	AS1175	
SA08302	AS1038		SA10204	AS1142		SA21602	AS2168	
SA08401	AS1039		SA10212	AS1040	AS3021	SA21603	AS2169	
SA08402	AS1040		SA10213	AS1041	AS3021	SA21702	AS2170	
SA08403	AS1041		SA10302	AS1043	AS3019	SA21802	AS2171	
SA08502	AS1040	AS3001	SA10303	AS1044	AS3019	SA21902	AS2172	
SA08602	AS1032	AS3000	SA10304	AS1045	AS3019	SA21903	AS2173	
SA08603	AS1033	AS3000	SA10401	AS1137		SA21604	AS2174	
SA08604	AS1034	AS3013	SA10402	AS1138		SA21904	AS2175	
SA08702	AS1036	AS3000	SA10501	AS1139		SAS1000	AS1033	
SA08802	AS1038	AS3000	SA10502	AS1140		SAS1001	AS1041	
SA08902	AS1040	AS3000	SA10503	AS1141		SAS1002	AS1044	
SA08903	AS1041	AS3000	SA10602	AS1146		SAS1003	AS1032 <sup>(1)</sup>	
SA08904	AS1042	AS3000	SA10603	AS1033	AS3018	SAS1003	AS1034 <sup>(12)</sup>	
SA08912	AS1040	AS3021	SA10604	AS1034	AS3018	SAS1004	AS1040 <sup>(1)</sup>	
SA08913	AS1041	AS3021	SA10613	AS1033	AS3015	SAS1004	AS1042 <sup>(12)</sup>	
SA09002	AS1043	AS3000	SA10702	AS1036	AS3018	SAS1005	AS1036	
SA09003	AS1044	AS3000	SA10801	AS1039	AS3018	SAS1006	AS1043 <sup>(1)</sup>	
SA09004	AS1045	AS3000	SA10802	AS1040	AS3018	SAS1006	AS1045 <sup>(12)</sup>	

<sup>(1)</sup> For 5.5" arm lengths only.

<sup>(12)</sup> For 6.5" arm lengths only.

The Enhanced Gunite 2000 design can be installed on a range of OEM applications currently in use today. It is recommended for use with vehicles manufactured after Phase I RSD requirements took effect in August 2011.

## CROSS REFERENCES

### GUNITE PRODUCTION TO GUNITE AFTERMARKET

Gunite Production P/N	Gunite Aftermarket P/N	Gunite Clevis Kit P/N	Gunite Production P/N	Gunite Aftermarket P/N	Gunite Clevis Kit P/N	Gunite Production P/N	Gunite Aftermarket P/N	Gunite Clevis Kit P/N
SAS1007	AS1038		SAS1048	AS1131		SAS1162	AS1162	
SAS1008	AS1140		SAS1049	AS1132		SAS1163	AS1163	
SAS1009	AS1140		SAS1050	AS1133		SAS1164	AS1164	
SAS1010	AS1138		SAS1051	AS1136		SAS1165	AS1165	
SAS1011	AS1038		SAS1052	AS1138		SAS1166	AS1166	
SAS1008	AS1140		SAS1053	AS1139		SAS1167	AS1167	
SAS1009	AS1140		SAS1054	AS1140		SAS1168	AS1168	
SAS1010	AS1138		SAS1055	AS1141		SAS1169	AS1169	
SAS1011	AS1038		SAS1056	AS1044	AS3019	SAS1170	AS1170	
SAS1012	AS1040		SAS1057	AS1141		SAS1171	AS1171	
SAS1013	AS1035		SAS1058	AS1141		SAS1172	AS1172	
SAS1014	AS1031		SAS1059	AS1040	AS3000	SAS1173	AS1173	
SAS1015	AS1037		SAS1060	AS1033	AS3000	SAS1174	AS1174	
SAS1016	AS1039		SAS1061	AS1140		SAS1175	AS1175	
SAS1017	AS1037		SAS1062	AS1141		SAS3000	AS3000	
SAS1018	AS1039		SAS1131	AS1131		SAS3001	AS3001	
SAS1019	AS1032		SAS1132	AS1132		SAS3002	AS3002	
SAS1020	AS1040		SAS1133	AS1133		SAS3003	AS3003	
SAS1021	AS1043		SAS1134	AS1134		SAS3004	AS3016	
SAS1022	AS1140		SAS1135	AS1135		SAS3005	AS3017	
SAS1023	AS1140		SAS1136	AS1136		SAS3011	AS3011	
SAS1024	AS1138		SAS1137	AS1137		SAS3012	AS3012	
SAS1025	AS1034		SAS1138	AS1138		SAS3013	AS3013	
SAS1026	AS1042		SAS1139	AS1139		SAS3015	AS3015	
SAS1027	AS1045		SAS1140	AS1140		SAS3016	AS3016	
SAS1028	AS1138		SAS1141	AS1141		SAS3017	AS3017	
SAS1029	AS1140		SAS1142	AS1142		SAS3018	AS3018	
SAS1030	AS1140		SAS1143	AS1143		SAS3019	AS3019	
SAS1031	AS1031		SAS1144	AS1144		SAS3021	AS3021	
SAS1032	AS1032		SAS1145	AS1145		SAS4001	AS4001	
SAS1033	AS1033		SAS1146	AS1146		SAS4004	AS4004	
SAS1034	AS1034		SAS1147	AS1147		SAS4005	AS4005	
SAS1035	AS1035		SAS1148	AS1148		SAS4006	AS4006	
SAS1036	AS1036		SAS1149	AS1149		SAS4007	AS4007	
SAS1037	AS1037		SAS1150	AS1150		SAS4008	AS4008	
SAS1038	AS1038		SAS1151	AS1151		SAS4012	AS4012	
SAS1039	AS1039		SAS1152	AS1152		SAS4013	AS4013	
SAS1040	AS1040		SAS1153	AS1153		SAS4014	AS4014	
SAS1041	AS1041		SAS1154	AS1154		SAS4015	AS4015	
SAS1042	AS1042		SAS1155	AS1155				
SAS1043	AS1043		SAS1156	AS1156				
SAS1044	AS1044		SAS1157	AS1157				
SAS1045	AS1045		SAS1159	AS1159				
SAS1046	AS1138		SAS1160	AS1160				
SAS1047	AS1140		SAS1161	AS1161				

## CROSS REFERENCES

### OEM TO GUNITE

OEM P/N	Gunite Production P/N	Gunite Aftermarket P/N
<b>Arvin Meritor</b>		
1227S1553	SD06301	
2245D1200	SD06201	
A2-3275-N1079	SA03101	AS1138
A13-3275M1079	SA10102	AS1138
A15-3275M1079	SA10502	AS1140
A18-3275M1079	SA08903	AS1041 <sup>(13)</sup>
A24-3275M1079	SA08902	AS1140 <sup>(13)</sup>
A26-3275M1079	SA08502	AS1140 <sup>(13)</sup>
A27-3275M1079	SA09802	AS1040 <sup>(13)</sup>
A28-3275M1079	SA08103	AS1041
A30-3275M1079	SA08102	AS1040
A31-3275M1079	SA10202	AS1140
A32-3275M1079	SA10802	AS1040 <sup>(13)</sup>
A34-3275M1079	SA08104	AS1042
A35-3275M1079	SA10204	AS1142
<b>Dana Corporation</b>		
25QD51	SA10202	AS1140
25QD51P2	SA09902	AS1132
25QD51P3	SA10203	AS1141
25QD365	SA07701	AS4013
25QD415	SA08903	AS1041 <sup>(13)</sup>
974294	SA09902	AS1132
974295	SA09903	AS1133
974296	SA10002	AS1136
M16WR1331	SA02101	AS1133
M16WR1331	SA11003	AS1033 <sup>(13)</sup>
M16WR1332	SA02201	AS1141
M16WR1332	SA11103	AS1041 <sup>(13)</sup>
M16WR1333	SA02104	AS1132
M16WR1334	SA11102	AS1040 <sup>(13)</sup>
M16WR1335	SA02105	AS1134
<b>Dexter Axle</b>		
055-011-05	SA02101	AS1133
055-040-04	SA02201	AS1141
055-040-05	SA05802	AS1041 <sup>(13)</sup>
<b>Dorsey Trailer</b>		
1191037	SA02201	AS1141
1191037	SA05802	AS1041 <sup>(13)</sup>
1191037	SA10803	AS1041 <sup>(13)</sup>

OEM P/N	Gunite Production P/N	Gunite Aftermarket P/N
<b>Ford Motor Company</b>		
87HU2314AA	SA02203	AS1140
E7HZ2314A	SA02203	AS1140
E9HT2308B	SA03101	AS1138
E9HT2308BA	SA03401	AS1138
E9HT2308BB	SA04101	AS1138
E9HT2314AA	SA03602	AS1141
E9HT2314BA	SA03601	AS1140
E9HT2314BB	SA04201	AS1140
E9HZ2308B		AS1138
E9HZ2314B		AS1140
F1HS2314AA	SA04203	AS1139
F2HS-2N038-CA	SD05001	AS4006
F2HS-2N038-DA	SD00601	AS4006
F2HS-9825-CA	SD00501	AS4006
F2HS-9825-DA	SD00701	AS4006
F2HS2308BA	SA04801	AS1039
F2HS2308CA	SA04802	AS1040
F2HS2308DA	SA04803	AS1041
F2HS2314CA	SA04701	AS1037
F2HS2314DA	SA04702	AS1038
F2HS2314EA	SA04703	
F8HT2314AA	SA10502	AS1140
F8HT2314BA	SA10503	AS1141
F8HZ2308AA	SAS1046	AS1138
F8HZ2314AA	SAS1047	AS1140
F8HZ2314BA	SAS1058	AS1141
F8HZ2N220AA	SAS3019	AS3019
<b>Freightliner LLC</b>		
6814100849	SA03101	AS1138
6814200849	SA03101	AS1138
6814201949	SA02204	AS1142
6814202049	SA02212	AS1157
6814202149	SA02213	AS1157
6814205538	SA02701	AS1136
6814205539	SA02701	AS1136
6814205638	SA02203	AS1140
6814205738	SA02104	AS1132
6814230050	SD04401	AS3000
76404-3410	SD06201	
76404-3412	SA07702	
76404-3413	SA07701	
76401-3509	SA10203	AS1141

OEM P/N	Gunite Production P/N	Gunite Aftermarket P/N
<b>Freightliner LLC (continued)</b>		
76401-3510	SA10204	AS1142
76401-3505	SA09902	AS1132
76401-3506	SA09903	AS1133
76401-3508	SA10202	AS1140
76401-3526	SA09502	AS1156
76401-3527	SA09802	AS1040 <sup>(13)</sup>
F8HT 2314 AA	SA10502	AS1140
F8HT 2314 BA	SA10503	AS1141
GUN AS1031		AS1031
GUN AS1032		AS1032
GUN AS1033		AS1033
GUN AS1034		AS1034
GUN AS1035		AS1035
GUN AS1036		AS1036
GUN AS1037		AS1037
GUN AS1038		AS1038
GUN AS1039		AS1039
GUN AS1040		AS1040
GUN AS1041		AS1041
GUN AS1042		AS1042
GUN AS1043		AS1043
GUN AS1044		AS1044
GUN AS1045		AS1045
GUN AS1131		AS1131
GUN AS1132		AS1132
GUN AS1133		AS1133
GUN AS1134		AS1134
GUN AS1135		AS1135
GUN AS1136		AS1136
GUN AS1137		AS1137
GUN AS1138		AS1138
GUN AS1139		AS1139
GUN AS1140		AS1140
GUN AS1141		AS1141
GUN AS1142		AS1142
GUN AS1143		AS1143
GUN AS1144		AS1144
GUN AS1145		AS1145
GUN AS1146		AS1146
GUN AS1147		AS1147
GUN AS1148		AS1148
GUN AS1149		AS1149
GUN AS1150		AS1150

Gunite Production part numbers that are in the third column of each table are for reference only, and used only on original equipment installation.

<sup>(13)</sup> Consult either the Numerical Listing or the Gunite Production to Gunite Aftermarket Part Number listings to determine the appropriate Gunite Clevis Kit required.



# CROSS REFERENCES

## OEM TO GUNITE

OEM P/N	Gunite Production P/N	Gunite Aftermarket P/N
<b>Freightliner LLC (continued)</b>		
GUN AS1151		AS1151
GUN AS1152		AS1152
GUN AS1153		AS1153
GUN AS1154		AS1154
GUN AS1155		AS1155
GUN AS1156		AS1156
GUN AS1157		AS1157
GUN AS1159		AS1159
GUN AS1160		AS1160
GUN AS1161		AS1161
GUN AS1162		AS1162
GUN AS1163		AS1163
GUN AS1164		AS1164
GUN AS1165		AS1165
GUN AS1166		AS1166
GUN AS1167		AS1167
GUN AS1168		AS1168
GUN AS1169		AS1169
GUN AS1170		AS1170
GUN AS1171		AS1171
GUN AS1172		AS1172
GUN AS1173		AS1173
GUN AS1174		AS 1174
GUN AS1175		AS1175
GUN AS3000		AS3000
GUN AS3001		AS3001
GUN AS3002		AS3002
GUN AS3003		AS3003
GUN AS3011		AS3011
GUN AS3012		AS3012
GUN AS3013		AS3013
GUN AS3015		AS3015
GUN AS3016		AS3016
GUN AS3017		AS3017
GUN AS3018		AS3018
GUN AS3019		AS3019
GUN AS3021		AS3021
GUN AS4001		AS4001
GUN AS4004		AS4004
GUN AS4005		AS4005
GUN AS4006		AS4006
GUN AS4007		AS4007
GUN AS4008		AS4008

OEM P/N	Gunite Production P/N	Gunite Aftermarket P/N
<b>Freightliner LLC (continued)</b>		
GUN AS4012		AS4012
GUN AS4013		AS4013
GUN AS4014		AS4014
GUN AS4015		AS4015
GUNASA02110	SA02110	AS1156
GUNASA02111	SA02111	AS1156
GUNASD06001	SD06001	
GUNASD06001	SD06001	
GUNASD06201	SD06201	
GUNASD06202	SD06202	
GUNASD06301	SD06301	
GUNASF00301	SA01501	AS3003
GUNASF01502	SA07501	AS3016
GUNSA085 02	SA08502	AS1040 <sup>(13)</sup>
GUNSA089 02	SA08902	AS1040 <sup>(13)</sup>
GUNSA095 02	SA09502	AS1156
GUNSA098 02	SA09802	AS1040 <sup>(13)</sup>
GUNSA099 02	SA09902	AS1132
GUNSA099 03	SA09903	AS1133
GUNSA100 02	SA10002	AS1136
GUNSA102 02	SA10202	AS1140
GUNSA102 03	SA10203	AS1141
GUNSA11602	SA11602	AS1146
GUNSA11603	SA11603	AS1169 <sup>(13)</sup>
GUNSA11702	SA11702	AS1170
GUNSA11902	SA11902	AS1172
GUNSA11903	SA11903	AS1173
GUNSD004 01	SD00401	
GUNSD004 02	SD00402	
GUNSD006 01	SD00601	
GUNSD006 02	SD00602	
<b>Freuehauf Corporation</b>		
00-20105	SA01201	AS1040 <sup>(13)</sup>
00-20106	SA01101	AS1032 <sup>(13)</sup>
00-20114	SA01302	AS1044 <sup>(13)</sup>
00-20115	SA01202	AS1041 <sup>(13)</sup>
00-20116	SA01002	AS1043 <sup>(13)</sup>
00-20124	SA01303	AS1045 <sup>(13)</sup>
00-20125	SA01203	AS1042 <sup>(13)</sup>
00-20126	SA01103	AS1034 <sup>(13)</sup>
ACF004205810	SA02402	AS1133
ACF004205828	SA02502	AS1141
ACF004205937	SA02601	AS1043 <sup>(13)</sup>

OEM P/N	Gunite Production P/N	Gunite Aftermarket P/N
<b>Freuehauf Corporation (continued)</b>		
ACF004205810	SA09103	AS1033 <sup>(13)</sup>
ACF004205828	SA09203	AS1041 <sup>(13)</sup>
ACF004205837	SA09302	AS1043 <sup>(13)</sup>
ACF3411-1	SA02301	AS1044 <sup>(13)</sup>
ACF3411-2	SA05601	AS1043 <sup>(13)</sup>
ACF3411-2	SA02302	AS1043 <sup>(13)</sup>
ANB25191	SA05901	AS1143
<b>Great Dane Trailer</b>		
42521	SA02201	AS1141
40501501	SA05802	AS1041 <sup>(13)</sup>
40501502	SA05801	AS1040 <sup>(13)</sup>
40501502	SA10803	AS1041 <sup>(13)</sup>
40501502	SA10802	AS1040 <sup>(13)</sup>
<b>Hendrickson Trailer Suspension</b>		
A-15156	SA09903	AS1133
A-15189	SA10602	AS1146
A-8651	SA10603	AS1033 <sup>(13)</sup>
A-14767	SA10802	AS1040 <sup>(13)</sup>
A-14768	SA10803	AS1041 <sup>(13)</sup>
006126	SA10101	AS1137
<b>International Truck &amp; Engine</b>		
2014290C1	SA01401	AS3000
2014291C1	SA01701	AS3001
2014292C1	SA01501	AS3003
2014293C1	SA01601	AS3002
ZBRAS1031		AS1031
ZBRAS1032		AS1032
ZBRAS1033		AS1033
ZBRAS1034		AS1034
ZBRAS1035		AS1035
ZBRAS1036		AS1036
ZBRAS1037		AS1037
ZBRAS1038		AS1038
ZBRAS1039		AS1039
ZBRAS1040		AS1040
ZBRAS1041		AS1041
ZBRAS1042		AS1042
ZBRAS1043		AS1043
ZBRAS1044		AS1044
ZBRAS1045		AS1045
ZBRAS1131		AS1131
ZBRAS1134		AS1134
ZBRAS1135		AS1135

Gunite Production part numbers that are in the third column of each table are for reference only, and used only on original equipment installation.

<sup>(13)</sup> Consult either the Numerical Listing or the Gunite Production to Gunite Aftermarket Part Number listings to determine the appropriate Gunite Clevis Kit required.

## CROSS REFERENCES

### OEM TO GUNITE

OEM P/N	Gunite Production P/N	Gunite Aftermarket P/N
<b>International Truck &amp; Engine (continued)</b>		
ZBRAS1136		AS1136
ZBRAS1137		AS1137
ZBRAS1138		AS1138
ZBRAS1139		AS1139
ZBRAS1140		AS1140
ZBRAS1141		AS1141
ZBRAS1142		AS1142
ZBRAS1143		AS1143
ZBRAS1144		AS1144
ZBRAS1145		AS1145
ZBRAS1146		AS1146
ZBRAS1147		AS1147
ZBRAS1148		AS1148
ZBRAS1149		AS1149
ZBRAS1150		AS1150
ZBRAS1151		AS1151
ZBRAS1152		AS1152
ZBRAS1153		AS1153
ZBRAS1154		AS1154
ZBRAS1155		AS1155
ZBRAS1156		AS1156
ZBRAS1157		AS1157
ZBRAS1159		AS1159
ZBRAS1160		AS1160
ZBRAS1161		AS1161
ZBRAS1162		AS1162
ZBRAS1163		AS1163
ZBRAS1164		AS1164
ZBRAS1165		AS1165
ZBRAS1166		AS1166
ZBRAS1167		AS1167
ZBRAS1168		AS1168
ZBRAS1169		AS1169
ZBRAS1170		AS1170
ZBRAS1171		AS1171
ZBRAS1172		AS1172
ZBRAS1173		AS1173
ZBRAS1174		AS 1174
ZBRAS1175		AS1175
ZBRAS1176		AS1176
ZBRAS1179		AS1179
ZBRAS3000		AS3000
ZBRAS3001		AS3001

OEM P/N	Gunite Production P/N	Gunite Aftermarket P/N
<b>International Truck &amp; Engine (continued)</b>		
ZBRAS3002		AS3002
ZBRAS3003		AS3003
ZBRAS3011		AS3011
ZBRAS3012		AS3012
ZBRAS3013		AS3013
ZBRAS3015		AS3015
ZBRAS3016		AS3016
ZBRAS3017		AS3017
ZBRAS3018		AS3018
ZBRAS3019		AS3019
ZBRAS3021		AS3021
ZBRAS3022		AS3022
ZBRAS3023		AS3023
ZBRAS3024		AS3024
ZBRAS4001		AS4001
ZBRAS4004		AS4004
ZBRAS4005		AS4005
ZBRAS4006		AS4006
ZBRAS4007		AS4007
ZBRAS4008		AS4008
ZBRAS4012		AS4012
ZBRAS4013		AS4013
ZBRAS4014		AS4014
ZBRAS4015		AS4015
3820002201	SA02201	AS1141
3820002203	SA02203	AS1140
3820007202	SA07203	AS1041 <sup>(13)</sup>
3820010802	SA10802	AS1040 <sup>(13)</sup>
3820010803	SA10803	AS1041 <sup>(13)</sup>
<b>Hyundai Translead</b>		
10000031	SA10803	AS1041 <sup>(13)</sup>
10000033	SA10802	AS1040 <sup>(13)</sup>
10000083	SD00402	
10000084	SD00602	
10009560	SA07601	AS3018
10007048	SD02801	
10010717	SA10602	AS1146
10010800	SA10603	AS1033 <sup>(13)</sup>
10010801	SA07801	AS1031
10010802	SA07601	AS3018
10012509	SA10903	AS1144

OEM P/N	Gunite Production P/N	Gunite Aftermarket P/N
<b>Mack Trucks Incorporated</b>		
25QD51	SA10202	AS1140
25QD51P2	SA09902	AS1132
25QD51P3	SA10203	AS1141
25QD365	SA07701	AS4013
25QD365P3	SA07703	n/a
25QD415	SA08903	AS1041 <sup>(13)</sup>
25QD419	SA11602	AS1168
25QD419P2	SA11902	AS1172
25QD419P3	SA11603	AS1169
25QD419P4	SA11903	AS1173
3398-AS1031		AS1031
3398-AS1032		AS1032
3398-AS1033		AS1033
3398-AS1034		AS1034
3398-AS1035		AS1035
3398-AS1036		AS1036
3398-AS1037		AS1037
3398-AS1038		AS1038
3398-AS1039		AS1039
3398-AS1040		AS1040
3398-AS1041		AS1041
3398-AS1042		AS1042
3398-AS1043		AS1043
3398-AS1044		AS1044
3398-AS1045		AS1045
3398-AS1131		AS1131
3398-AS1132		AS1132
3398-AS1133		AS1133
3398-AS1134		AS1134
3398-AS1135		AS1135
3398-AS1136		AS1136
3398-AS1137		AS1137
3398-AS1138		AS1138
3398-AS1139		AS1139
3398-AS1140		AS1140
3398-AS1141		AS1141
3398-AS1142		AS1142
3398-AS1143		AS1143
3398-AS1144		AS1144
3398-AS1145		AS1145
3398-AS1146		AS1146
3398-AS1147		AS1147
3398-AS1148		AS1148

Gunite Production part numbers that are in the third column of each table are for reference only, and used only on original equipment installation.

<sup>(13)</sup> Consult either the Numerical Listing or the Gunite Production to Gunite Aftermarket Part Number listings to determine the appropriate Gunite Clevis Kit required.

# CROSS REFERENCES

## OEM TO GUNITE

OEM P/N	Gunite Production P/N	Gunite Aftermarket P/N
<b>Mack Trucks Incorporated (continued)</b>		
3398-AS1149		AS1149
3398-AS1150		AS1150
3398-AS1151		AS1151
3398-AS1152		AS1152
3398-AS1153		AS1153
3398-AS1154		AS1154
3398-AS1155		AS1155
3398-AS1156		AS1156
3398-AS1157		AS1157
3398-AS1159		AS1159
3398-AS1160		AS1160
3398-AS1161		AS1161
3398-AS1162		AS1162
3398-AS1163		AS1163
3398-AS1164		AS1164
3398-AS1165		AS1165
3398-AS1166		AS1166
3398-AS1167		AS1167
3398-AS1168		AS1168
3398-AS1169		AS1169
3398-AS1170		AS1170
3398-AS1171		AS1171
3398-AS1172		AS1172
3398-AS1173		AS1173
3398-AS1174		AS 1174
3398-AS1175		AS1175
3398-AS1176		AS1176
3398-AS1179		AS1179
3398-AS3000		AS3000
3398-AS3001		AS3001
3398-AS3002		AS3002
3398-AS3003		AS3003
3398-AS3011		AS3011
3398-AS3012		AS3012
3398-AS3013		AS3013
3398-AS3015		AS3015
3398-AS3016		AS3016
3398-AS3017		AS3017
3398-AS3018		AS3018
3398-AS3019		AS3019
3398-AS3021		AS3021
3398-AS3022		AS3022
3398-AS3023		AS3023
3398-AS3024		AS3024
3398-AS4001		AS4001

OEM P/N	Gunite Production P/N	Gunite Aftermarket P/N
<b>Mack Trucks Incorporated (continued)</b>		
3398-AS4004		AS4004
3398-AS4005		AS4005
3398-AS4006		AS4006
3398-AS4007		AS4007
3398-AS4008		AS4008
3398-AS4012		AS4012
3398-AS4013		AS4013
3398-AS4014		AS4014
3398-AS4015		AS4015
<b>Peterbilt Motors Company</b>		
10480701	SA02104	AS1132
10480801	SA02203	AS1140
02-01736	SA02701	AS1136
02-02245	SA02701	AS1136
03-05136	SA02203	AS1140
03-05229	SA02203	AS1140
03-05459	SA02204	AS1142
03-06008	SA02104	AS1132
<b>Stoughton</b>		
046034700100	SA10802	AS1149
<b>Strick Corporation</b>		
03637/16167	SA05801	AS1040 <sup>(13)</sup>
R21097003	SA02203	AS1140
R21097004	SA02201	AS1141
<b>Trailmobile Incorporated</b>		
17A23127	SA02203	AS1140
17A2314355	SA07202	AS1040 <sup>(13)</sup>
17A2314355	SA10802	AS1040 <sup>(13)</sup>
17A2314360	SA10803	AS1041 <sup>(13)</sup>
4017A23665	SA02201	AS1141
<b>Volvo Trucks North America</b>		
1090339		AS1033
1090340		AS1041
1090341		AS1044
1090342		AS1032
1090343		AS1040
1090344		AS3000
1090345		AS3001
1091671		AS1038
1092019		AS1040
1092020		AS1038
1099346		AS4001
20434458	SA10204	AS1142
20527305	SA11602	AS1168
20527306	SA11702	AS1170

OEM P/N	Gunite Production P/N	Gunite Aftermarket P/N
<b>Volvo Trucks North America (continued)</b>		
20527307	SA11902	AS1172
20714924	SA11903	AS1173
20714928	SA11603	AS1169
3918358		AS1032
3918359		AS1034
3918360		AS1040
3918361		AS1042
3918977		AS3001
3919764		AS3003
3919765		AS3002
3936094	SA00105	AS1036
3936096	SA00102	AS1032
3936102	SA01701	AS3001
3936103	SA01401	AS3000
3947846		AS1033
3947847		AS1032
3947848		AS1036
3947849		AS1041
3948150		AS1040
3948970		AS1038
3949413		AS1042
3949441		AS1034
3949442		AS1044
76401-0100	SA02201	AS1141
76401-0103	SA02101	AS1133
76401-0110	SA02203	AS1140
76401-0111	SA02701	AS1136
76401-0134	SA02104	AS1132
76401-0149	SA03101	AS1138
76401-3805	SA02104	AS1132
76401-3806	SA02204	AS1142
76403-0003	SD04401	AS3000
76403-0004	SD04402	AS3001
8060850	SA02101	AS1133
8060851	SA02104	AS1132
8060852	SA03101	AS1138
8060853	SA02701	AS1136
8060858	SA02201	AS1141
8060859	SA02203	AS1140
8060999	SA02212	AS1157
8061000	SA02213	AS1157
8084128	SA09903	AS1133
8084129	SA09902	AS1132
8084131	SA10002	AS1136

Gunite Production part numbers that are in the third column of each table are for reference only, and used only on original equipment installation.

<sup>(13)</sup> Consult either the Numerical Listing or the Gunite Production to Gunite Aftermarket Part Number listings to determine the appropriate Gunite Clevis Kit required.

Features and Benefits  
Numerical Listings  
Axle Applications  
Obsolete Products  
Cross References



## CROSS REFERENCES

### OEM TO GUNITE

OEM P/N	Gunite Production P/N	Gunite Aftermarket P/N
<b>Volvo Trucks North America (continued)</b>		
8084131	SA10002	AS1136
8084132	SA10203	AS1141
8084133	SA10202	AS1140
8084136	SD06301	n/a
8084138	SD06203	n/a
8160525	SD06002	AS4011
8160526	SD06001	AS4010
<b>Wabash National Corporation</b>		
10600055	SA02201	AS1141
10600059	SA10802	AS1149
10600361	SA05502	AS1041 <sup>(13)</sup>
<b>Western Star Truck</b>		
76401-3455	SA02104	AS1132
76401-3457	SA02701	AS1136
76401-3462	SA02203	AS1140
76401-3469	SA03101	AS1138
76401-3498	SA06402	AS1132
76401-3499	SA06403	AS1133
76401-3501	SA06602	AS1136
76401-3502	SA07002	AS1140
76401-3505	SA09902	AS1132
76401-3506	SA09903	AS1133
76401-3507	SA10002	AS1136
76401-3508	SA10202	AS1140
76401-3509	SA10203	AS1141
76401-3510	SA10204	AS1142

Gunite Production part numbers that are in the third column of each table are for reference only, and used only on original equipment installation.

<sup>(13)</sup> Consult either the Numerical Listing or the Gunite Production to Gunite Aftermarket Part Number listings to determine the appropriate Gunite Clevis Kit required.

# CROSS REFERENCES

## INDUSTRY TO GUNITE

Industry P/N	Gunité Aftermarket P/N	Special Information
<b>Bendix Corporation</b>		
065162	AS1035	Requires the use of AS3002 clevis kit.
065163	AS1036	Requires the use of AS3003 clevis kit.
065163	AS1153	
065164	AS1036	Requires the use of either AS3001 or AS3017 clevis kits.
065164	AS1136	
065166	AS1037	Requires the use of AS3002 clevis kit.
065167	AS1038	Requires the use of either AS3000 or AS3016 clevis kits.
065167	AS1138	
065168	AS1031	Requires the use of AS3001 clevis kit.
065169	AS1032	Requires the use of AS3002 clevis kit.
065169	AS1156	
065170	AS1032	Requires the use of either AS3000 or AS3016 clevis kits.
065170	AS1132	
065172	AS1033	Requires the use of either AS3000 or AS3016 clevis kits.
065172	AS1133	
065173	AS1039	Requires the use of AS3001 clevis kit.
065174	AS1040	Requires the use of either AS3000 or AS3016 clevis kits.
065174	AS1140	
065175	AS1041	Requires the use of either AS3000 or AS3016 clevis kits.
065175	AS1141	
065176	AS1041	Requires the use of either AS3000 or AS3016 clevis kits.
065176	AS1141	
065177	AS1044	Requires the use of either AS3000 or AS3016 clevis kits.
065178	AS1043	Requires the use of either AS3000 or AS3016 clevis kits.
065179	AS1044	Requires the use of either AS3000 or AS3016 clevis kits.
065182	AS1043	Requires the use of either AS3000 or AS3016 clevis kits.
065221	AS1040	Requires the use of either AS3001 or AS3017 clevis kits.
065221	AS1140	
065244	AS1036	Requires the use of AS3002 clevis kit.
065244	AS1152	
065245	AS1040	Requires the use of AS3002 clevis kit.
065247	AS1040	Requires the use of either AS3000 or AS3016 clevis kits.
065247	AS1140	
065274	AS1038	Requires the use of either AS3001 or AS3017 clevis kits.
065274	AS1138	
065276	AS1041	Requires the use of AS3002 clevis kit.
065306	AS1038	Requires the use of AS3002 clevis kit.
065306	AS1154	
065335	AS1038	Requires the use of either AS3001 or AS3017 clevis kits.
065335	AS1138	
065344	AS1033	Requires the use of either AS3000 or AS3016 clevis kits.
065344	AS1133	
065403	AS1038	Requires the use of either AS3000 or AS3016 clevis kits.
065403	AS1138	

Industry P/N	Gunité Aftermarket P/N	Special Information
<b>Bendix Corporation (continued)</b>		
065488	AS1032	Requires the use of AS3003 clevis kit.
065508	AS1031	Requires the use of either AS3000 or AS3016 clevis kits.
065508	AS1131	
065700	AS1032	Requires the use of either AS3000 or AS3016 clevis kits.
065700	AS1132	
101261	AS1040	Requires the use of either AS3000 or AS3016 clevis kits.
101261	AS1140	
101262	AS1040	Requires the use of either AS3000 or AS3016 clevis kits.
101262	AS1140	
101453	AS1036	Requires the use of either AS3001 or AS3017 clevis kits.
101453	AS1136	
101454	AS1036	Requires the use of either AS3001 or AS3017 clevis kits.
101454	AS1136	
101539	AS1036	Requires the use of either AS3001 or AS3017 clevis kits.
101539	AS1136	
101540	AS1036	Requires the use of either AS3001 or AS3017 clevis kits.
101540	AS1136	
101628	AS1032	Requires the use of AS3002 clevis kit.
101628	AS1156	
101629	AS1032	Requires the use of AS3002 clevis kit.
101629	AS1156	
101769	AS1040	Requires the use of either AS3000 or AS3016 clevis kits.
101769	AS1140	
101770	AS1040	Requires the use of either AS3000 or AS3016 clevis kits.
101770	AS1140	
106900	AS1039	Requires the use of AS3001 clevis kit.
106902	AS1039	Requires the use of AS3001 clevis kit.
106194	AS1033	Requires the use of either AS3000 or AS3016 clevis kits.
106194	AS1133	
106195	AS1032	Requires the use of either AS3000 or AS3016 clevis kits.
106195	AS1132	
106196	AS1031	Requires the use of AS3001 clevis kit.
106197	AS1036	Requires the use of AS3003 clevis kit.
106197	AS1153	
106198	AS1036	Requires the use of AS3003 clevis kit.
106198	AS1153	
106201	AS1041	Requires the use of either AS3000 or AS3016 clevis kits.
106201	AS1141	
106202	AS1044	Requires the use of either AS3000 or AS3016 clevis kits.
106203	AS1036	Requires the use of either AS3001 or AS3017 clevis kits.
106203	AS1136	
106204	AS1040	Requires the use of either AS3000 or AS3016 clevis kits.
106204	AS1140	
106205	AS1032	Requires the use of either AS3000 or AS3016 clevis kits.

**Replacement of other brands of slack adjusters should be done in axle sets.** Industry Part Numbers referencing more than a single interchange is the result of Gunité offering the option of ordering its Automatic Slack Adjusters with or without the clevis kit.

Features and Benefits

Numerical Listings

Axle Applications

Obsolete Products

Cross References

## CROSS REFERENCES

### INDUSTRY TO GUNITE

Industry P/N	Gunite Aftermarket P/N	Special Information
<b>Bendix Corporation (continued)</b>		
106205	AS1132	
106206	AS1036	Requires the use of either AS3001 or AS3017 clevis kits.
106206	AS1136	
106207	AS1040	Requires the use of either AS3000 or AS3016 clevis kits.
106207	AS1140	
106208	AS1036	Requires the use of AS3002 clevis kit.
106208	AS1152	
106209	AS1036	Requires the use of AS3002 clevis kit.
106209	AS1152	
106321	AS1032	Requires the use of AS3002 clevis kit.
106321	AS1156	
106322	AS1032	Requires the use of AS3002 clevis kit.
106322	AS1156	
106901	AS1031	Requires the use of AS3001 clevis kit.
106903	AS1037	Requires the use of AS3002 clevis kit.
106905	AS1037	Requires the use of AS3002 clevis kit.
106906	AS1037	Requires the use of AS3002 clevis kit.
106908	AS1037	Requires the use of AS3002 clevis kit.
106926	AS1041	Requires the use of either AS3000 or AS3016 clevis kits.
106926	AS1141	
107100	AS1033	Requires the use of either AS3000 or AS3016 clevis kits.
107100	AS1133	
107101	AS1041	Requires the use of either AS3000 or AS3016 clevis kits.
107101	AS1141	
107102	AS1044	Requires the use of either AS3000 or AS3016 clevis kits.
107103	AS1032	Requires the use of either AS3000 or AS3016 clevis kits.
107103	AS1132	
107104	AS1036	Requires the use of either AS3001 or AS3017 clevis kits.
107104	AS1136	
107105	AS1040	Requires the use of either AS3000 or AS3016 clevis kits.
107105	AS1140	
107106	AS1032	Requires the use of either AS3000 or AS3016 clevis kits.
107106	AS1132	
107107	AS1036	Requires the use of either AS3001 or AS3017 clevis kits.
107107	AS1136	
107108	AS1040	Requires the use of either AS3000 or AS3016 clevis kits.
107108	AS1140	
107109	AS1031	Requires the use of AS3001 clevis kit.
107110	AS1039	Requires the use of AS3001 clevis kit.
107111	AS1031	Requires the use of AS3001 clevis kit.
107112	AS1039	Requires the use of AS3001 clevis kit.
107113	AS1036	Requires the use of AS3003 clevis kit.
107113	AS1153	
107114	AS1036	Requires the use of AS3002 clevis kit.

Industry P/N	Gunite Aftermarket P/N	Special Information
<b>Bendix Corporation (continued)</b>		
107114	AS1152	
107115	AS1032	Requires the use of AS3002 clevis kit.
107115	AS1156	
107116	AS1036	Requires the use of AS3003 clevis kit.
107116	AS1153	
107117	AS1036	Requires the use of AS3002 clevis kit.
107117	AS1152	
107118	AS1032	Requires the use of AS3002 clevis kit.
107118	AS1156	
107120	AS1037	Requires the use of AS3002 clevis kit.
107122	AS1037	Requires the use of AS3002 clevis kit.
107124	AS1037	Requires the use of AS3002 clevis kit.
107126	AS1037	Requires the use of AS3002 clevis kit.
107127	AS1041	Requires the use of either AS3000 or AS3016 clevis kits.
107127	AS1141	
107142	AS1038	Requires the use of either AS3001 or AS3017 clevis kits.
107142	AS1138	
107143	AS1040	Requires the use of either AS3000 or AS3016 clevis kits.
107143	AS1140	
107144	AS1040	Requires the use of either AS3000 or AS3016 clevis kits.
107144	AS1140	
107176	AS1032	Requires the use of either AS3000 or AS3016 clevis kits.
107176	AS1132	
107177	AS1036	Requires the use of either AS3001 or AS3017 clevis kits.
107177	AS1136	
107178	AS1038	Requires the use of either AS3001 or AS3017 clevis kits.
107178	AS1138	
107179	AS1040	Requires the use of either AS3000 or AS3016 clevis kits.
107179	AS1140	
107246	AS1038	Requires the use of either AS3000 or AS3016 clevis kits.
107246	AS1138	
107247	AS1038	Requires the use of either AS3000 or AS3016 clevis kits.
107247	AS1138	
107254	AS1043	Requires the use of either AS3000 or AS3016 clevis kits.
107256	AS1038	Requires the use of either AS3000 or AS3016 clevis kits.
107256	AS1138	
107262	AS1032	Requires the use of either AS3000 or AS3016 clevis kits.
107262	AS1132	
107263	AS1036	Requires the use of either AS3001 or AS3017 clevis kits.
107263	AS1136	
107264	AS1044	Requires the use of either AS3000 or AS3016 clevis kits.
107265	AS1044	Requires the use of either AS3000 or AS3016 clevis kits.
107267	AS1036	Requires the use of either AS3001 or AS3017 clevis kits.
107267	AS1136	

**Replacement of other brands of slack adjusters should be done in axle sets.** Industry Part Numbers referencing more than a single interchange is the result of Gunite offering the option of ordering its Automatic Slack Adjusters with or without the clevis kit.



# CROSS REFERENCES

## INDUSTRY TO GUNITE

Industry P/N	Gunite Aftermarket P/N	Special Information
<b>Bendix Corporation (continued)</b>		
107269	AS1037	Requires the use of AS3002 clevis kit.
107270	AS1038	Requires the use of either AS3000 or AS3016 clevis kits.
107270	AS1138	
107271	AS1031	Requires the use of AS3001 clevis kit.
107272	AS1032	Requires the use of AS3002 clevis kit.
107272	AS1156	
107273	AS1032	Requires the use of either AS3000 or AS3016 clevis kits.
107273	AS1132	
107274	AS1033	Requires the use of either AS3000 or AS3016 clevis kits.
107274	AS1133	
107275	AS1039	Requires the use of AS3001 clevis kit.
107276	AS1040	Requires the use of either AS3000 or AS3016 clevis kits.
107276	AS1140	
107277	AS1041	Requires the use of either AS3000 or AS3016 clevis kits.
107277	AS1141	
107278	AS1041	Requires the use of either AS3000 or AS3016 clevis kits.
107278	AS1141	
107279	AS1044	Requires the use of either AS3000 or AS3016 clevis kits.
107280	AS1043	Requires the use of either AS3000 or AS3016 clevis kits.
107281	AS1044	Requires the use of either AS3000 or AS3016 clevis kits.
107297	AS1036	Requires the use of either AS3001 or AS3017 clevis kits. Check Spline diameter.
107297	AS1136	Check Spline diameter.
107297	AS1032	Requires the use of either AS3000 or AS3016 clevis kits. Check Spline diameter.
107297	AS1132	Check Spline diameter.
107400	AS1033	Requires the use of either AS3000 or AS3016 clevis kits.
107400	AS1133	
107401	AS1033	Requires the use of either AS3000 or AS3016 clevis kits.
107401	AS1133	
107402	AS1040	Requires the use of either AS3000 or AS3016 clevis kits.
107402	AS1140	
107403	AS1040	Requires the use of either AS3000 or AS3016 clevis kits.
107403	AS1140	
107407	AS1043	Requires the use of either AS3000 or AS3016 clevis kits.
107408	AS1043	Requires the use of either AS3000 or AS3016 clevis kits.
107409	AS1043	Requires the use of either AS3000 or AS3016 clevis kits.
107420	AS1038	Requires the use of either AS3000 or AS3016 clevis kits.
107420	AS1138	
107421	AS1040	Requires the use of either AS3000 or AS3016 clevis kits.
107421	AS1140	
107477	AS1036	Requires the use of either AS3001 or AS3017 clevis kits.
107477	AS1136	
107536	AS1040	Requires the use of either AS3000 or AS3016 clevis kits.
107536	AS1140	

Industry P/N	Gunite Aftermarket P/N	Special Information
<b>Bendix Corporation (continued)</b>		
107687	AS1040	Requires the use of either AS3001 or AS3017 clevis kits.
107687	AS1140	
107688	AS1040	Requires the use of either AS3001 or AS3017 clevis kits.
107688	AS1140	
107689	AS1040	Requires the use of either AS3001 or AS3017 clevis kits.
107689	AS1140	
107729	AS1036	Requires the use of AS3002 clevis kit.
107729	AS1152	
107730	AS1036	Requires the use of AS3002 clevis kit.
107730	AS1152	
107734	AS1040	Requires the use of AS3002 clevis kit.
107735	AS1040	Requires the use of AS3002 clevis kit.
107736	AS1041	Requires the use of either AS3000 or AS3016 clevis kits.
107736	AS1141	
107739	AS1040	Requires the use of either AS3000 or AS3016 clevis kits.
107739	AS1140	
107772	AS1041	Requires the use of either AS3000 or AS3016 clevis kits.
107772	AS1141	
107773	AS1041	Requires the use of either AS3000 or AS3016 clevis kits.
107773	AS1141	
107774	AS1041	Requires the use of AS3002 clevis kit.
107775	AS1041	Requires the use of AS3002 clevis kit.
107787	AS1041	Requires the use of either AS3000 or AS3016 clevis kits.
107787	AS1141	
107788	AS1040	Requires the use of either AS3000 or AS3016 clevis kits.
107788	AS1140	
107789	AS1040	Requires the use of AS3002 clevis kit.
107790	AS1040	Requires the use of AS3002 clevis kit.
107907	AS1031	Requires the use of AS3001 clevis kit.
107944	AS1033	Requires the use of either AS3000 or AS3016 clevis kits.
107944	AS1133	
107991	AS1040	Requires the use of either AS3000 or AS3016 clevis kits.
107991	AS1140	
107992	AS1038	Requires the use of either AS3000 or AS3016 clevis kits.
107992	AS1138	
107993	AS1033	Requires the use of either AS3000 or AS3016 clevis kits.
107993	AS1133	
107994	AS1041	Requires the use of either AS3000 or AS3016 clevis kits.
107994	AS1141	
107995	AS1032	Requires the use of either AS3000 or AS3016 clevis kits.
107995	AS1132	
107996	AS1040	Requires the use of either AS3000 or AS3016 clevis kits.
107996	AS1140	
107997	AS1040	Requires the use of either AS3000 or AS3016 clevis kits.

**Replacement of other brands of slack adjusters should be done in axle sets.** Industry Part Numbers referencing more than a single interchange is the result of Gunite offering the option of ordering its Automatic Slack Adjusters with or without the clevis kit.

Features and Benefits

Numerical Listings

Axle Applications

Obsolete Products

Cross References

## CROSS REFERENCES

### INDUSTRY TO GUNITE

Industry P/N	Gunite Aftermarket P/N	Special Information
<b>Bendix Corporation (continued)</b>		
107997	AS1140	
107998	AS1036	Requires the use of either AS3001 or AS3017 clevis kits.
107998	AS1136	
107999	AS1032	Requires the use of either AS3000 or AS3016 clevis kits.
107999	AS1132	
108000	AS1038	Requires the use of either AS3001 or AS3017 clevis kits.
108000	AS1138	
108001	AS1031	Requires the use of AS3001 clevis kit.
108068	AS1040	Requires the use of either AS3000 or AS3016 clevis kits.
108068	AS1140	
108091	AS1041	Requires the use of either AS3000 or AS3016 clevis kits.
108091	AS1141	
108092	AS1033	Requires the use of either AS3000 or AS3016 clevis kits.
108092	AS1133	
108093	AS1041	Requires the use of either AS3000 or AS3016 clevis kits.
108093	AS1141	
108117	AS1041	Requires the use of either AS3000 or AS3016 clevis kits.
108117	AS1141	
108118	AS1040	Requires the use of either AS3000 or AS3016 clevis kits.
108118	AS1140	
108119	AS1040	Requires the use of AS3002 clevis kit.
108120	AS1040	Requires the use of AS3002 clevis kit.
108292	AS1038	Requires the use of AS3002 clevis kit.
108292	AS1154	
108293	AS1038	Requires the use of AS3002 clevis kit.
108293	AS1154	
108371	AS1040	Requires the use of either AS3000 or AS3016 clevis kits.
108371	AS1140	
108430	AS1041	Requires the use of either AS3000 or AS3016 clevis kits.
108430	AS1141	
108431	AS1033	Requires the use of either AS3000 or AS3016 clevis kits.
108431	AS1133	
108555	AS1038	Requires the use of either AS3001 or AS3017 clevis kits.
108555	AS1138	
108617	AS1033	Requires the use of either AS3000 or AS3016 clevis kits.
108617	AS1133	
108644	AS1036	Requires the use of either AS3001 or AS3017 clevis kits.
108644	AS1136	
108645	AS1040	Requires the use of either AS3000 or AS3016 clevis kits.
108645	AS1140	
108646	AS1038	Requires the use of either AS3000 or AS3016 clevis kits.
108646	AS1138	
108647	AS1032	Requires the use of either AS3000 or AS3016 clevis kits.
108647	AS1132	

Industry P/N	Gunite Aftermarket P/N	Special Information
<b>Bendix Corporation (continued)</b>		
108966	AS1038	Requires the use of AS3002 clevis kit.
108966	AS1154	
108967	AS1038	Requires the use of AS3002 clevis kit.
108967	AS1154	
108974	AS1038	Requires the use of either AS3001 or AS3017 clevis kits.
108974	AS1138	
109038	AS1038	Requires the use of either AS3001 or AS3017 clevis kits.
109038	AS1138	
109271	AS1032	Requires the use of AS3003 clevis kit.
109272	AS1032	Requires the use of AS3003 clevis kit.
109277	AS1038	Requires the use of AS3002 clevis kit.
109277	AS1154	
109278	AS1038	Requires the use of AS3002 clevis kit.
108278	AS1154	
109357	AS1031	Requires the use of either AS3000 or AS3016 clevis kits.
109357	AS1131	
109344	AS1032	Requires the use of AS3002 clevis kit.
109344	AS1156	
109345	AS1032	Requires the use of AS3002 clevis kit.
109345	AS1156	
109516	AS1040	Requires the use of AS3002 clevis kit.
109517	AS1038	Requires the use of AS3002 clevis kit.
109517	AS1154	
109518	AS1040	Requires the use of either AS3000 or AS3016 clevis kits.
109518	AS1140	
109519	AS1041	Requires the use of either AS3000 or AS3016 clevis kits.
109519	AS1141	
109627	AS1041	Requires the use of AS3002 clevis kit.
109628	AS1041	Requires the use of AS3002 clevis kit.
131026	AS1032	Requires the use of either AS3000 or AS3016 clevis kits.
131026	AS1132	
289304	AS1036	Requires the use of AS3002 clevis kit.
289304	AS1152	
289305	AS1036	Requires the use of AS3002 clevis kit.
289305	AS1152	
289312	AS1041	Requires the use of either AS3000 or AS3016 clevis kits.
289312	AS1141	
289313	AS1041	Requires the use of either AS3000 or AS3016 clevis kits.
289313	AS1141	
289314	AS1040	Requires the use of either AS3000 or AS3016 clevis kits.
289314	AS1140	
289315	AS1040	Requires the use of either AS3000 or AS3016 clevis kits.
289315	AS1140	
289325	AS1044	Requires the use of either AS3000 or AS3016 clevis kits.

**Replacement of other brands of slack adjusters should be done in axle sets.** Industry Part Numbers referencing more than a single interchange is the result of Gunite offering the option of ordering its Automatic Slack Adjusters with or without the clevis kit.

# CROSS REFERENCES

## INDUSTRY TO GUNITE

Industry P/N	Gunite Aftermarket P/N	Special Information
<b>Bendix Corporation (continued)</b>		
289652	AS1033	Requires the use of either AS3000 or AS3016 clevis kits.
289652	AS1133	
289653	AS1033	Requires the use of either AS3000 or AS3016 clevis kits.
289653	AS1133	
289654	AS1032	Requires the use of either AS3000 or AS3016 clevis kits.
289654	AS1132	
289655	AS1032	Requires the use of either AS3000 or AS3016 clevis kits.
289655	AS1132	
289741	AS1033	Requires the use of either AS3000 or AS3016 clevis kits.
289741	AS1133	
289742	AS1033	Requires the use of either AS3000 or AS3016 clevis kits.
289742	AS1133	
289746	AS1032	Requires the use of either AS3000 or AS3016 clevis kits.
289746	AS1132	
289747	AS1032	Requires the use of either AS3000 or AS3016 clevis kits.
289747	AS1132	
289746	AS1032	Requires the use of either AS3000 or AS3016 clevis kits.
289746	AS1132	
289747	AS1032	Requires the use of either AS3000 or AS3016 clevis kits.
289747	AS1132	
289748	AS1032	Requires the use of either AS3000 or AS3016 clevis kits.
289748	AS1132	
289749	AS1032	Requires the use of either AS3000 or AS3016 clevis kits.
289749	AS1132	
289933	AS1041	Requires the use of either AS3000 or AS3016 clevis kits.
289933	AS1141	
289934	AS1041	Requires the use of either AS3000 or AS3016 clevis kits.
289934	AS1141	
5001334	AS1036	Requires the use of either AS3001 or AS3017 clevis kits.
5001334	AS1136	
801351	AS1036	Requires the use of either AS3000 or AS3016 clevis kits.
801351	AS1136	
801352	AS1031	Requires the use of either AS3000 or AS3016 clevis kits.
801352	AS1131	
801353	AS1032	Requires the use of either AS3001 or AS3017 clevis kits.
801353	AS1132	
801354	AS1039	Requires the use of either AS3000 or AS3016 clevis kits.
801354	AS1139	
801355	AS1040	Requires the use of either AS3001 or AS3017 clevis kits.
801355	AS1140	
801356	AS1041	Requires the use of AS3001 clevis kit.
801357	AS1037	Requires the use of AS3003 clevis kit.
801358	AS1032	Requires the use of AS3003 clevis kit.
801359	AS1035	Requires the use of AS3003 clevis kit.

Industry P/N	Gunite Aftermarket P/N	Special Information
<b>Bendix Corporation (continued)</b>		
801353	AS1132	
801354	AS1039	Requires the use of either AS3000 or AS3016 clevis kits.
801354	AS1139	
801355	AS1040	Requires the use of either AS3001 or AS3017 clevis kits.
801355	AS1140	
801356	AS1041	Requires the use of AS3001 clevis kit.
801357	AS1037	Requires the use of AS3003 clevis kit.
801358	AS1032	Requires the use of AS3003 clevis kit.
801359	AS1035	Requires the use of AS3003 clevis kit.
<b>Stemco Crewson</b>		
MB21102	AS1032	Requires the use of either AS3000 or AS3016 clevis kits. 5.5" arm length only.
MB21102	AS1132	5.5" arm length only.
MB21102	AS1034	Requires the use of either AS3000 or AS3016 clevis kits. 6.5" arm length only.
MB21102	AS1134	6.5" arm length only.
MB21103	AS1031	Requires the use of either AS3000 or AS3016 clevis kits. 5.0" arm length only.
MB21103	AS1131	5.0" arm length only.
MB21103	AS1033	Requires the use of either AS3000 or AS3016 clevis kits. 6.0" arm length only.
MB21103	AS1133	6.0" arm length only.
MB21104	AS1033	Requires the use of either AS3000 or AS3016 clevis kits. 6.0" arm length only.
MB21104	AS1133	6.0" arm length only.
MB21182	AS1032	Requires the use of either AS3000 or AS3016 clevis kits. 5.5" arm length only.
MB21182	AS1132	5.5" arm length only.
MB21182	AS1034	Requires the use of either AS3000 or AS3016 clevis kits. 6.5" arm length only.
MB21182	AS1134	6.5" arm length only.
MB21184	AS1033	Requires the use of either AS3000 or AS3016 clevis kits. 6.0" arm length only.
MB21184	AS1133	6.0" arm length only.
MB21182	AS1034	Requires the use of either AS3000 or AS3016 clevis kits. 6.5" arm length only.
MB21182	AS1134	6.5" arm length only.
MB21184	AS1033	Requires the use of either AS3000 or AS3016 clevis kits. 6.0" arm length only.
MB21184	AS1133	6.0" arm length only.
MB21183	AS1031	Requires the use of either AS3000 or AS3016 clevis kits. 5.0" arm length only.
MB21183	AS1131	5.0" arm length only.
MB21183	AS1033	Requires the use of either AS3000 or AS3016 clevis kits. 6.0" arm length only.
MB21183	AS1133	6.0" arm length only.
MB21952	AS1032	Requires the use of either AS3000 or AS3016 clevis kits. 5.5" arm length only.
MB21952	AS1132	5.5" arm length only.
MB21952	AS1034	Requires the use of either AS3000 or AS3016 clevis kits. 6.5" arm length only.
MB21952	AS1134	6.5" arm length only.
MB21953	AS1031	Requires the use of either AS3000 or AS3016 clevis kits. 5.0" arm length only.

**Replacement of other brands of slack adjusters should be done in axle sets.** Industry Part Numbers referencing more than a single interchange is the result of Gunite offering the option of ordering its Automatic Slack Adjusters with or without the clevis kit.

Features and Benefits  
Numerical Listings  
Axle Applications  
Obsolete Products  
Cross References



## CROSS REFERENCES

### INDUSTRY TO GUNITE

Industry P/N	Gunite Aftermarket P/N	Special Information
<b>Stemco Crewson (continued)</b>		
MB21953	AS1131	5.0" arm length only.
MB21953	AS1033	Requires the use of either AS3000 or AS3016 clevis kits. 6.0" arm length only.
MB21953	AS1133	6.0" arm length only.
MB22102	AS1040	Requires the use of either AS3000 or AS3016 clevis kits. 5.5" arm length only.
MB22102	AS1140	5.5" arm length only.
MB22102	AS1042	Requires the use of either AS3000 or AS3016 clevis kits. 6.5" arm length only.
MB22102	AS1142	6.5" arm length only.
MB22103	AS1039	Requires the use of either AS3000 or AS3016 clevis kits. 5.0" arm length only.
MB22103	AS1139	5.0" arm length only.
MB22103	AS1041	Requires the use of either AS3000 or AS3016 clevis kits. 6.0" arm length only.
MB22103	AS1141	6.0" arm length only.
MB22104	AS1041	Requires the use of either AS3000 or AS3016 clevis kits. 6.0" arm length only.
MB22104	AS1141	6.0" arm length only.
MB22182	AS1040	Requires the use of either AS3000 or AS3016 clevis kits. 5.5" arm length only.
MB22182	AS1140	5.5" arm length only.
MB22182	AS1042	Requires the use of either AS3000 or AS3016 clevis kits. 6.5" arm length only.
MB22182	AS1142	6.5" arm length only.
MB22183	AS1039	Requires the use of either AS3000 or AS3016 clevis kits. 5.0" arm length only.
MB22183	AS1139	5.0" arm length only.
MB22183	AS1041	Requires the use of either AS3000 or AS3016 clevis kits. 6.0" arm length only.
MB22183	AS1141	6.0" arm length only.
MB22184	AS1041	Requires the use of either AS3000 or AS3016 clevis kits. 6.0" arm length only.
MB22184	AS1141	6.0" arm length only.
MB22952	AS1040	Requires the use of either AS3000 or AS3016 clevis kits. 5.5" arm length only.
MB22952	AS1140	5.5" arm length only.
MB22953	AS1039	Requires the use of either AS3000 or AS3016 clevis kits. 5.0" arm length only.
MB22953	AS1139	5.0" arm length only.
MB22953	AS1041	Requires the use of either AS3000 or AS3016 clevis kits. 6.0" arm length only.
MB22953	AS1141	6.0" arm length only.
MB23102	AS1043	Requires the use of either AS3000 or AS3016 clevis kits. 5.5" arm length only.
MB23102	AS1143	5.5" arm length only.
MB23106	AS1044	Requires the use of either AS3000 or AS3016 clevis kits.
MB23106	AS1144	
MB23952	AS1043	Requires the use of either AS3000 or AS3016 clevis kits. 5.5" arm length only.
MB23952	AS1143	5.5" arm length only.
MB23952	AS1045	Requires the use of either AS3000 or AS3016 clevis kits. 6.5" arm length only.
MB23952	AS1145	6.5" arm length only.
MB23953	AS1044	Requires the use of either AS3000 or AS3016 clevis kits. 6.0" arm length only.

Industry P/N	Gunite Aftermarket P/N	Special Information
<b>Stemco Crewson (continued)</b>		
MB23953	AS1144	6.0" arm length only.
MB24102	AS1036	Requires the use of either AS3000 or AS3016 clevis kits. 5.5" arm length only.
MB24102	AS1136	5.5" arm length only.
MB24103	AS1035	Requires the use of either AS3000 or AS3016 clevis kits. 5.0" arm length only.
MB24103	AS1135	5.0" arm length only.
MB24300	AS1036	Requires the use of AS3003 clevis kit.
MB25102	AS1038	Requires the use of either AS3000 or AS3016 clevis kits. 5.5" arm length only.
MB25102	AS1138	5.5" arm length only.
MB25103	AS1037	Requires the use of either AS3000 or AS3016 clevis kits. 5.0" arm length only.
MB25103	AS1137	5.0" arm length only.
MB25300	AS1038	Requires the use of AS3003 clevis kit.
MB34100	AS1036	Requires the use of either AS3000 or AS3016 clevis kits.
MB34100	AS1136	
MB34200	AS1036	Requires the use of either AS3000 or AS3016 clevis kits.
MB34200	AS1136	
MB35100	AS1038	Requires the use of either AS3000 or AS3016 clevis kits.
MB35100	AS1138	
MB35200	AS1038	Requires the use of either AS3001 or AS3017 clevis kits.
MB35200	AS1138	
MB41100	AS1032	Requires the use of either AS3000 or AS3016 clevis kits.
MB41100	AS1132	
MB41101	AS1034	Requires the use of either AS3000 or AS3016 clevis kits.
MB41101	AS1134	
MB41106	AS1033	Requires the use of either AS3000 or AS3016 clevis kits.
MB41106	AS1133	
MB41180	AS1032	Requires the use of either AS3000 or AS3016 clevis kits.
MB41180	AS1132	
MB41186	AS1033	Requires the use of either AS3000 or AS3016 clevis kits.
MB41186	AS1133	
MB42100	AS1040	Requires the use of either AS3000 or AS3016 clevis kits.
MB42100	AS1140	
MB42101	AS1042	Requires the use of either AS3000 or AS3016 clevis kits.
MB42101	AS1142	
MB42106	AS1041	Requires the use of either AS3000 or AS3016 clevis kits.
MB42106	AS1141	
MB42180	AS1040	Requires the use of either AS3000 or AS3016 clevis kits.
MB42180	AS1140	
MB42186	AS1041	Requires the use of either AS3000 or AS3016 clevis kits.
MB42186	AS1141	
MB43100	AS1043	Requires the use of either AS3000 or AS3016 clevis kits.
MB43100	AS1143	
MB43106	AS1044	Requires the use of either AS3000 or AS3016 clevis kits.
MB43106	AS1144	

**Replacement of other brands of slack adjusters should be done in axle sets.** Industry Part Numbers referencing more than a single interchange is the result of Gunite offering the option of ordering its Automatic Slack Adjusters with or without the clevis kit.

# CROSS REFERENCES

## INDUSTRY TO GUNITE

Industry P/N	Gunite Aftermarket P/N	Special Information
<b>Stemco Crewson (continued)</b>		
MB43180	AS1043	Requires the use of either AS3000 or AS3016 clevis kits.
MB43180	AS1143	
MB43186	AS1044	Requires the use of either AS3000 or AS3016 clevis kits.
MB43186	AS1144	
MB71100	AS1032	Requires the use of either AS3000 or AS3016 clevis kits.
MB71100	AS1132	
MB71106	AS1033	Requires the use of either AS3000 or AS3016 clevis kits.
MB71106	AS1133	
MB72100	AS1040	Requires the use of either AS3000 or AS3016 clevis kits.
MB72100	AS1140	
MB72106	AS1041	Requires the use of either AS3000 or AS3016 clevis kits.
MB72106	AS1141	
MB73106	AS1044	Requires the use of either AS3000 or AS3016 clevis kits.
MB73106	AS1144	
CI21102	AS1032	Requires the use of either AS3000 or AS3016 clevis kits. 5.5" arm length only.
CI21102	AS1132	5.5" arm length only.
CI21102	AS1034	Requires the use of either AS3000 or AS3016 clevis kits. 6.5" arm length only.
CI21102	AS1134	6.5" arm length only.
CI211A2	AS1032	Requires the use of either AS3000 or AS3016 clevis kits. 5.5" arm length only.
CI211A2	AS1132	5.5" arm length only.
CI211A2	AS1034	Requires the use of either AS3000 or AS3016 clevis kits. 6.5" arm length only.
CI211A2	AS1134	6.5" arm length only.
CI21103	AS1031	Requires the use of either AS3000 or AS3016 clevis kits. 5.0" arm length only.
CI21103	AS1131	5.0" arm length only.
CI211A3	AS1031	Requires the use of either AS3000 or AS3016 clevis kits. 5.0" arm length only.
CI211A3	AS1131	5.0" arm length only.
CI211A3	AS1033	Requires the use of either AS3000 or AS3016 clevis kits. 6.0" arm length only.
CI211A3	AS1133	6.0" arm length only.
CI22102	AS1040	Requires the use of either AS3000 or AS3016 clevis kits. 5.5" arm length only.
CI22102	AS1140	5.5" arm length only.
CI22102	AS1042	Requires the use of either AS3000 or AS3016 clevis kits. 6.5" arm length only.
CI22102	AS1142	6.5" arm length only.
CI221A2	AS1040	Requires the use of either AS3000 or AS3016 clevis kits. 5.5" arm length only.
CI221A2	AS1140	5.5" arm length only.
CI221A2	AS1042	Requires the use of either AS3000 or AS3016 clevis kits. 6.5" arm length only.
CI221A2	AS1142	6.5" arm length only.
CI22103	AS1039	Requires the use of either AS3000 or AS3016 clevis kits. 5.0" arm length only.
CI22103	AS1139	5.0" arm length only.
CI22103	AS1041	Requires the use of either AS3000 or AS3016 clevis kits. 6.0" arm length only.
CI22103	AS1141	6.0" arm length only.

Industry P/N	Gunite Aftermarket P/N	Special Information
<b>Stemco Crewson (continued)</b>		
CI221A3	AS1039	Requires the use of either AS3000 or AS3016 clevis kits. 5.0" arm length only.
CI221A3	AS1139	5.0" arm length only.
CI221A3	AS1041	Requires the use of either AS3000 or AS3016 clevis kits. 6.0" arm length only.
CI221A3	AS1141	6.0" arm length only.
CI23103	AS1044	Requires the use of either AS3000 or AS3016 clevis kits. 6.0" arm length only.
CI23103	AS1144	6.0" arm length only.
CI24102	AS1036	Requires the use of either AS3000 or AS3016 clevis kits. 5.5" arm length only.
CI24102	AS1136	5.5" arm length only.
CI24103	AS1035	Requires the use of either AS3000 or AS3016 clevis kits. 5.0" arm length only.
CI24103	AS1135	5.0" arm length only.
CI25102	AS1038	Requires the use of either AS3000 or AS3016 clevis kits. 5.5" arm length only.
CI25102	AS1138	5.5" arm length only.
CI25103	AS1037	Requires the use of either AS3000 or AS3016 clevis kits. 5.0" arm length only.
CI25103	AS1137	5.0" arm length only.
CI34100	AS1036	Requires the use of either AS3000 or AS3016 clevis kits.
CI34100	AS1136	
CI34200	AS1038	Requires the use of either AS3001 or AS3017 clevis kits.
CI34200	AS1138	
CI41100	AS1032	Requires the use of either AS3000 or AS3016 clevis kits.
CI41100	AS1132	
CI411A0	AS1032	Requires the use of either AS3000 or AS3016 clevis kits.
CI411A0	AS1132	
CI41106	AS1033	Requires the use of either AS3000 or AS3016 clevis kits.
CI41106	AS1133	
CI411A6	AS1033	Requires the use of either AS3000 or AS3016 clevis kits.
CI411A6	AS1133	
CI42100	AS1040	Requires the use of either AS3000 or AS3016 clevis kits.
CI42100	AS1140	
CI421A0	AS1040	Requires the use of either AS3000 or AS3016 clevis kits.
CI421A0	AS1140	
CI42106	AS1041	Requires the use of either AS3000 or AS3016 clevis kits.
CI42106	AS1141	
CI421A6	AS1041	Requires the use of either AS3000 or AS3016 clevis kits.
CI421A6	AS1141	
CI43100	AS1043	Requires the use of either AS3000 or AS3016 clevis kits.
CI43100	AS1143	
CI43106	AS1044	Requires the use of either AS3000 or AS3016 clevis kits.
CI43106	AS1144	
CI71100	AS1032	Requires the use of either AS3000 or AS3016 clevis kits.
CI71100	AS1132	
CI71106	AS1033	Requires the use of either AS3000 or AS3016 clevis kits.
CI71106	AS1133	

**Replacement of other brands of slack adjusters should be done in axle sets.** Industry Part Numbers referencing more than a single interchange is the result of Gunite offering the option of ordering its Automatic Slack Adjusters with or without the clevis kit.

Features and Benefits

Numerical Listings

Axle Applications

Obsolete Products

Cross References

## CROSS REFERENCES

### INDUSTRY TO GUNITE

Industry P/N	Gunite Aftermarket P/N	Special Information
<b>Stemco Crewson (continued)</b>		
CI72100	AS1040	Requires the use of either AS3000 or AS3016 clevis kits.
CI72100	AS1140	
CI72106	AS1041	Requires the use of either AS3000 or AS3016 clevis kits.
CI72106	AS1141	
CI73106	AS1044	Requires the use of either AS3000 or AS3016 clevis kits.
CI73106	AS1144	
<b>Eagle</b>		
52510	AS1032	Requires the use of a Gunite clevis kit.
52510	AS1132	
52511	AS1033	Requires the use of a Gunite clevis kit.
52511	AS1133	
52512	AS1032	Requires the use of a Gunite clevis kit.
52512	AS1132	
52513	AS1036	Requires the use of a Gunite clevis kit.
52513	AS1136	
52528	AS1040	Requires the use of a Gunite clevis kit.
52528	AS1140	
52529	AS1041	Requires the use of a Gunite clevis kit.
52529	AS1141	
52530	AS1040	Requires the use of a Gunite clevis kit.
52530	AS1140	
52538	AS1044	Requires the use of a Gunite clevis kit.
52538	AS1144	
<b>Dana Corporation</b>		
805812	AS1042	Requires the use of a Gunite clevis kit.
808112	AS1033	Haldex ASA. Requires a Gunite straight style clevis kit.
808113	AS1041	Haldex ASA. Requires a Gunite straight style clevis kit.
808114	AS1031	Haldex ASA. Requires a Gunite straight style clevis kit. 5.0" arm length only.
808114	AS1033	Haldex ASA. Requires a Gunite straight style clevis kit. 6.0" arm length only.
808115	AS1040	Haldex ASA. Requires a Gunite straight style clevis kit. 5.5" arm length only.
808115	AS1042	Haldex ASA. Requires a Gunite straight style clevis kit. 6.5" arm length only.
808116	AS1032	Haldex ASA. Requires a Gunite straight style clevis kit.
808119	AS1032	Haldex ASA. Requires a Gunite .625" offset style clevis kit.
808120	AS1032	Haldex ASA. Requires a Gunite .625" offset style clevis kit.
808121	AS1036	Haldex ASA. Requires a Gunite .625" offset style clevis kit.
808122	AS1036	Haldex ASA. Requires a Gunite .625" offset style clevis kit.
808123	AS1036	Haldex ASA. Requires a Gunite straight style clevis kit.
808124	AS1031	Haldex ASA. Requires a Gunite straight style clevis kit. 5.0" arm length only.
808124	AS1033	Haldex ASA. Requires a Gunite straight style clevis kit. 6.0" arm length only.
808125	AS1032	Haldex ASA. Requires a Gunite straight style clevis kit. 5.5" arm length only.
808125	AS1034	Haldex ASA. Requires a Gunite straight style clevis kit. 6.5" arm length only.

Industry P/N	Gunite Aftermarket P/N	Special Information
<b>Dana Corporation (continued)</b>		
808126	AS1041	Haldex ASA. Requires a Gunite straight style clevis kit.
808129	AS1039	Haldex ASA. Requires a Gunite straight style clevis kit. 5.0" arm length only.
808129	AS1041	Haldex ASA. Requires a Gunite straight style clevis kit. 6.0" arm length only.
808131	AS1040	Haldex ASA. Requires a Gunite straight style clevis kit.
808132	AS1040	Haldex ASA. Requires a Gunite straight style clevis kit. 5.5" arm length only.
808132	AS1042	Haldex ASA. Requires a Gunite straight style clevis kit. 6.5" arm length only.
808133	AS1044	Haldex ASA. Requires a Gunite straight style clevis kit.
808134	AS1040	Haldex ASA. Requires a Gunite straight style clevis kit. 5.5" arm length only.
808134	AS1042	Haldex ASA. Requires a Gunite straight style clevis kit. 6.5" arm length only.
808135	AS1033	Haldex ASA. Requires a Gunite straight style clevis kit.
808136	AS1032	Haldex ASA. Requires a Gunite straight style clevis kit.
808137	AS1041	Haldex ASA. Requires a Gunite straight style clevis kit.
808138	AS1040	Haldex ASA. Requires a Gunite straight style clevis kit.
808139	AS1032	Haldex ASA. Requires a Gunite straight style clevis kit. 5.5" arm length only.
808139	AS1034	Haldex ASA. Requires a Gunite straight style clevis kit. 6.5" arm length only.
808140	AS1031	Haldex ASA. Requires a Gunite straight style clevis kit. 5.0" arm length only.
808140	AS1033	Haldex ASA. Requires a Gunite straight style clevis kit. 6.0" arm length only.
808141	AS1040	Haldex ASA. Requires a Gunite straight style clevis kit. 5.5" arm length only.
808141	AS1042	Haldex ASA. Requires a Gunite straight style clevis kit. 6.5" arm length only.
808142	AS1039	Haldex ASA. Requires a Gunite straight style clevis kit. 5.0" arm length only.
808142	AS1041	Haldex ASA. Requires a Gunite straight style clevis kit. 6.0" arm length only.
808143	AS1032	Haldex ASA. Requires a Gunite straight style clevis kit. 5.5" arm length only.
808143	AS1034	Haldex ASA. Requires a Gunite straight style clevis kit. 6.5" arm length only.
808147	AS1038	Haldex ASA. Requires a Gunite straight style clevis kit.
808148	AS1033	Haldex ASA. Requires a Gunite straight style clevis kit.
808149	AS1041	Haldex ASA. Requires a Gunite straight style clevis kit.
808150	AS1031	Haldex ASA. Requires a Gunite straight style clevis kit. 5.0" arm length only.
808150	AS1033	Haldex ASA. Requires a Gunite straight style clevis kit. 6.0" arm length only.
808151	AS1040	Haldex ASA. Requires a Gunite straight style clevis kit. 5.5" arm length only.
808151	AS1042	Haldex ASA. Requires a Gunite straight style clevis kit. 6.5" arm length only.
808152	AS1032	Haldex ASA. Requires a Gunite straight style clevis kit.
808156	AS1032	Haldex ASA. Requires a Gunite .625" offset style clevis kit.
808157	AS1032	Haldex ASA. Requires a Gunite .625" offset style clevis kit.
808158	AS1036	Haldex ASA. Requires a Gunite .625" offset style clevis kit.
808159	AS1036	Haldex ASA. Requires a Gunite .625" offset style clevis kit.
808160	AS1036	Haldex ASA. Requires a Gunite straight style clevis kit.
808161	AS1031	Haldex ASA. Requires a Gunite straight style clevis kit. 5.0" arm length only.

**Replacement of other brands of slack adjusters should be done in axle sets.** Industry Part Numbers referencing more than a single interchange is the result of Gunite offering the option of ordering its Automatic Slack Adjusters with or without the clevis kit.

# CROSS REFERENCES

## INDUSTRY TO GUNITE

Industry P/N	Gunite Aftermarket P/N	Special Information
<b>Dana Corporation</b>		
808161	AS1033	Haldex ASA. Requires a Gunite straight style clevis kit. 6.0" arm length only.
808162	AS1032	Haldex ASA. Requires a Gunite straight style clevis kit. 5.5" arm length only.
808162	AS1034	Haldex ASA. Requires a Gunite straight style clevis kit. 6.5" arm length only.
808163	AS1041	Haldex ASA. Requires a Gunite straight style clevis kit.
808166	AS1039	Haldex ASA. Requires a Gunite straight style clevis kit. 5.0" arm length only.
808166	AS1041	Haldex ASA. Requires a Gunite straight style clevis kit. 6.0" arm length only.
808168	AS1040	Haldex ASA. Requires a Gunite straight style clevis kit.
808169	AS1040	Haldex ASA. Requires a Gunite straight style clevis kit. 5.5" arm length only.
808169	AS1042	Haldex ASA. Requires a Gunite straight style clevis kit. 6.5" arm length only.
808170	AS1044	Haldex ASA. Requires a Gunite straight style clevis kit.
808171	AS1040	Haldex ASA. Requires a Gunite straight style clevis kit. 5.5" arm length only.
808171	AS1042	Haldex ASA. Requires a Gunite straight style clevis kit. 6.5" arm length only.
808172	AS1033	Haldex ASA. Requires a Gunite straight style clevis kit.
808173	AS1032	Haldex ASA. Requires a Gunite straight style clevis kit.
808174	AS1041	Haldex ASA. Requires a Gunite straight style clevis kit.
808175	AS1040	Haldex ASA. Requires a Gunite straight style clevis kit.
808176	AS1032	Haldex ASA. Requires a Gunite straight style clevis kit. 5.5" arm length only.
808176	AS1034	Haldex ASA. Requires a Gunite straight style clevis kit. 6.5" arm length only.
808177	AS1031	Haldex ASA. Requires a Gunite straight style clevis kit. 5.0" arm length only.
808177	AS1033	Haldex ASA. Requires a Gunite straight style clevis kit. 6.0" arm length only.
808178	AS1040	Haldex ASA. Requires a Gunite straight style clevis kit. 5.5" arm length only.
808178	AS1042	Haldex ASA. Requires a Gunite straight style clevis kit. 6.5" arm length only.
808179	AS1039	Haldex ASA. Requires a Gunite straight style clevis kit. 5.0" arm length only.
808179	AS1041	Haldex ASA. Requires a Gunite straight style clevis kit. 6.0" arm length only.
808180	AS1032	Haldex ASA. Requires a Gunite straight style clevis kit. 5.5" arm length only.
808180	AS1034	Haldex ASA. Requires a Gunite straight style clevis kit. 6.5" arm length only.
808184	AS1038	Haldex ASA. Requires a Gunite straight style clevis kit.
808254	AS1140	Requires the use of a Gunite clevis kit. 5.5" arm length only.
808254	AS1142	6.5" arm length only.
808255	AS1031	Requires the use of a Gunite clevis kit.
808255	AS1131	
808354	AS1033	Haldex ASA. Requires a Gunite straight style clevis kit.
808375	AS1033	Haldex ASA. Requires a Gunite straight style clevis kit.
808382	AS1033	Haldex ASA. Requires a Gunite straight style clevis kit.
808679	AS1032	Haldex ASA. Requires a Gunite straight style clevis kit. 5.5" arm length only.
808679	AS1034	Haldex ASA. Requires a Gunite straight style clevis kit. 6.5" arm length only.
808684	AS1032	Haldex ASA. Requires a Gunite straight style clevis kit.

Industry P/N	Gunite Aftermarket P/N	Special Information
<b>Dana Corporation</b>		
808685	AS1039	Haldex ASA. Requires a Gunite straight style clevis kit. 5.0" arm length only.
808685	AS1041	Haldex ASA. Requires a Gunite straight style clevis kit. 6.0" arm length only.
808687	AS1033	Requires the use of a Gunite clevis kit.
808687	AS1133	
808688	AS1032	Haldex ASA. Requires a Gunite straight style clevis kit. 5.5" arm length only.
808688	AS1034	Haldex ASA. Requires a Gunite straight style clevis kit. 6.5" arm length only.
808689	AS1036	Haldex ASA. Requires a Gunite .625" offset style clevis kit.
808690	AS1036	Haldex ASA. Requires a Gunite .625" offset style clevis kit.
808691	AS1040	Haldex ASA. Requires a Gunite straight style clevis kit. 5.5" arm length only.
808691	AS1042	Haldex ASA. Requires a Gunite straight style clevis kit. 6.5" arm length only.
808692	AS1040	Haldex ASA. Requires a Gunite straight style clevis kit. 5.5" arm length only.
808692	AS1042	Haldex ASA. Requires a Gunite straight style clevis kit. 6.5" arm length only.
808693	AS1036	Haldex ASA. Requires a Gunite straight style clevis kit.
808694	AS1031	Requires the use of a Gunite clevis kit. 5.0" arm length only.
808694	AS1131	5.0" arm length only.
808694	AS1033	Requires the use of a Gunite clevis kit. 6.0" arm length only.
808694	AS1133	6.0" arm length only.
808695	AS1036	Haldex ASA. Requires a Gunite straight style clevis kit.
808746	AS1038	Haldex ASA. Requires a Gunite straight style clevis kit.
809490	AS1038	Requires the use of a Gunite clevis kit.
809490	AS1138	
809609	AS1032	Haldex ASA. Requires a Gunite straight style clevis kit.
809610	AS1032	Haldex ASA. Requires a Gunite straight style clevis kit.
809611	AS1040	Haldex ASA. Requires a Gunite straight style clevis kit.
809612	AS1040	Haldex ASA. Requires a Gunite straight style clevis kit.
809613	AS1032	Haldex ASA. Requires a Gunite straight style clevis kit.
809614	AS1039	Requires the use of a Gunite clevis kit. 5.0" arm length only.
809614	AS1139	5.0" arm length only.
809614	AS1041	Requires the use of a Gunite clevis kit. 6.0" arm length only.
809614	AS1141	6.0" arm length only.
809615	AS1031	Requires the use of a Gunite clevis kit. 5.0" arm length only.
809615	AS1131	5.0" arm length only.
809615	AS1033	Requires the use of a Gunite clevis kit. 6.0" arm length only.
809615	AS1133	6.0" arm length only.
809616	AS1033	Requires the use of a Gunite clevis kit.
809616	AS1133	
809617	AS1033	Requires the use of a Gunite clevis kit.
809617	AS1133	
809754	AS1036	Haldex ASA. Requires a Gunite straight style clevis kit.

**Replacement of other brands of slack adjusters should be done in axle sets.** Industry Part Numbers referencing more than a single interchange is the result of Gunite offering the option of ordering its Automatic Slack Adjusters with or without the clevis kit.

Features and Benefits  
Numerical Listings  
Axle Applications  
Obsolete Products  
Cross References



## CROSS REFERENCES

### INDUSTRY TO GUNITE

Industry P/N	Gunite Aftermarket P/N	Special Information
<b>Dana Corporation</b>		
809774	AS1036	Haldex ASA. Requires a Gunite straight style clevis kit.
809774	AS1136	
809775	AS1036	Requires the use of a Gunite clevis kit. 5.5" arm length only.
809775	AS1136	5.5" arm length only.
810047	AS1040	Haldex ASA. Requires a Gunite straight style clevis kit. 5.5" arm length only.
810047	AS1042	Haldex ASA. Requires a Gunite straight style clevis kit. 6.5" arm length only.
810180	AS1032	Haldex ASA. Requires a Gunite straight style clevis kit. 5.5" arm length only.
810180	AS1034	Haldex ASA. Requires a Gunite straight style clevis kit. 6.5" arm length only.
810336	AS1040	Requires the use of a Gunite clevis kit.
810336	AS1140	
810358	AS1038	Haldex ASA. Requires a Gunite straight style clevis kit.
810359	AS1038	Haldex ASA. Requires a Gunite straight style clevis kit.
810600	AS1040	Haldex ASA. Requires a Gunite straight style clevis kit. 5.5" arm length only.
810600	AS1042	Haldex ASA. Requires a Gunite straight style clevis kit. 6.5" arm length only.
810601	AS1039	Haldex ASA. Requires a Gunite straight style clevis kit. 5.0" arm length only.
810601	AS1041	Haldex ASA. Requires a Gunite straight style clevis kit. 6.0" arm length only.
810602	AS1040	Haldex ASA. Requires a Gunite straight style clevis kit. 5.5" arm length only.
810602	AS1042	Haldex ASA. Requires a Gunite straight style clevis kit. 6.5" arm length only.
810603	AS1039	Haldex ASA. Requires a Gunite straight style clevis kit. 5.0" arm length only.
810603	AS1041	Haldex ASA. Requires a Gunite straight style clevis kit. 6.0" arm length only.
810686	AS1043	Haldex ASA. Requires a Gunite straight style clevis kit.
810728	AS1032	Haldex ASA. Requires a Gunite straight style clevis kit. 5.5" arm length only.
810728	AS1034	Haldex ASA. Requires a Gunite straight style clevis kit. 6.5" arm length only.
810729	AS1036	Requires the use of a Gunite clevis kit.
810729	AS1136	
810730	AS1038	Requires the use of a Gunite clevis kit.
810730	AS1138	
810731	AS1040	Haldex ASA. Requires a Gunite straight style clevis kit. 5.5" arm length only.
810731	AS1042	Haldex ASA. Requires a Gunite straight style clevis kit. 6.5" arm length only.
810815	AS1032	Haldex ASA. Requires a Gunite straight style clevis kit. 5.5" arm length only.
810815	AS1034	Haldex ASA. Requires a Gunite straight style clevis kit. 6.5" arm length only.
810838	AS1031	Haldex ASA. Requires a Gunite straight style clevis kit. 5.0" arm length only.
810838	AS1033	Haldex ASA. Requires a Gunite straight style clevis kit. 6.0" arm length only.
810843	AS1040	Haldex ASA. Requires a Gunite straight style clevis kit. 5.5" arm length only.
810843	AS1042	Haldex ASA. Requires a Gunite straight style clevis kit. 6.5" arm length only.
811120	AS1040	Requires the use of a Gunite clevis kit. 5.5" arm length only.

Industry P/N	Gunite Aftermarket P/N	Special Information
<b>Dana Corporation</b>		
811120	AS1140	5.5" arm length only.
811120	AS1042	6.5" arm length only.
811120	AS1142	6.5" arm length only.
811121	AS1040	Haldex ASA. Requires a Gunite straight style clevis kit. 5.5" arm length only.
811121	AS1042	Haldex ASA. Requires a Gunite straight style clevis kit. 6.5" arm length only.
811336	AS1040	Haldex ASA. Requires a Gunite straight style clevis kit.
812351	AS1040	Haldex ASA. Requires a Gunite straight style clevis kit. 5.5" arm length only.
812351	AS1042	Haldex ASA. Requires a Gunite straight style clevis kit. 6.5" arm length only.
812642	AS1036	Requires the use of a Gunite clevis kit.
812642	AS1136	
812643	AS1036	Requires the use of a Gunite clevis kit.
812643	AS1136	
812926	AS1038	Haldex ASA. Requires a Gunite .625" offset style clevis kit.
812927	AS1038	Haldex ASA. Requires a Gunite .625" offset style clevis kit.
813246	AS1032	Requires the use of a Gunite clevis kit.
813246	AS1132	
813247	AS1032	Requires the use of a Gunite clevis kit.
813247	AS1132	
813638	AS1040	Haldex ASA. Requires a Gunite straight style clevis kit.
813639	AS1041	Haldex ASA. Requires a Gunite straight style clevis kit.
813640	AS1043	Haldex ASA. Requires a Gunite straight style clevis kit.
813641	AS1044	Haldex ASA. Requires a Gunite straight style clevis kit.
813642	AS1032	Haldex ASA. Requires a Gunite straight style clevis kit.
813643	AS1033	Haldex ASA. Requires a Gunite straight style clevis kit.
813648	AS1040	Haldex ASA. Requires a Gunite straight style clevis kit.
813649	AS1041	Haldex ASA. Requires a Gunite straight style clevis kit.
813650	AS1043	Haldex ASA. Requires a Gunite straight style clevis kit.
813651	AS1044	Haldex ASA. Requires a Gunite straight style clevis kit.
813652	AS1032	Haldex ASA. Requires a Gunite straight style clevis kit.
813653	AS1033	Haldex ASA. Requires a Gunite straight style clevis kit.
815787	AS1039	Requires the use of a Gunite clevis kit. 5.0" arm length only.
815787	AS1139	5.0" arm length only.
815787	AS1041	Requires the use of a Gunite clevis kit. 6.0" arm length only.
815787	AS1141	6.0" arm length only.
815788	AS1040	Requires the use of a Gunite clevis kit. 5.5" arm length only.
815788	AS1140	5.5" arm length only.
815788	AS1042	6.5" arm length only.
815788	AS1142	6.5" arm length only.
815789	AS1031	Requires the use of a Gunite clevis kit. 5.0" arm length only.
815789	AS1131	5.0" arm length only.
815789	AS1033	Requires the use of a Gunite clevis kit. 6.0" arm length only.

**Replacement of other brands of slack adjusters should be done in axle sets.** Industry Part Numbers referencing more than a single interchange is the result of Gunite offering the option of ordering its Automatic Slack Adjusters with or without the clevis kit.

# CROSS REFERENCES

## INDUSTRY TO GUNITE

Industry P/N	Gunite Aftermarket P/N	Special Information
<b>Dana Corporation</b>		
815789	AS1133	6.0" arm length only.
815790	AS1032	Requires the use of a Gunite clevis kit. 5.5" arm length only.
815790	AS1132	5.5" arm length only.
815790	AS1034	6.5" arm length only.
815790	AS1134	6.5" arm length only.
815792	AS1041	Requires the use of a Gunite clevis kit.
815792	AS1141	
815793	AS1040	Requires the use of a Gunite clevis kit. 5.5" arm length only.
815793	AS1140	5.5" arm length only.
815793	AS1042	6.5" arm length only.
815793	AS1142	6.5" arm length only.
815794	AS1033	Requires the use of a Gunite clevis kit.
815794	AS1133	
815795	AS1036	Requires the use of a Gunite clevis kit.
815795	AS1136	
815796	AS1036	Requires the use of a Gunite clevis kit.
815796	AS1136	
815797	AS1036	Requires the use of a Gunite clevis kit.
815797	AS1136	
815798	AS1038	Requires the use of a Gunite clevis kit.
815798	AS1138	
815799	AS1038	Requires the use of a Gunite clevis kit.
815799	AS1138	
815800	AS1038	Requires the use of a Gunite clevis kit.
815800	AS1138	
815801	AS1032	Requires the use of a Gunite clevis kit.
815801	AS1132	
815802	AS1040	Requires the use of a Gunite clevis kit.
815802	AS1140	
815806	AS1039	Haldex ASA. Requires a Gunite straight style clevis kit. 5.0" arm length only.
815806	AS1041	Haldex ASA. Requires a Gunite straight style clevis kit. 6.0" arm length only.
815807	AS1040	Haldex ASA. Requires a Gunite straight style clevis kit. 5.5" arm length only.
815807	AS1042	Haldex ASA. Requires a Gunite straight style clevis kit. 6.5" arm length only.
815808	AS1031	Haldex ASA. Requires a Gunite straight style clevis kit. 5.0" arm length only.
815808	AS1033	Haldex ASA. Requires a Gunite straight style clevis kit. 6.0" arm length only.
815809	AS1032	Haldex ASA. Requires a Gunite straight style clevis kit. 5.5" arm length only.
815809	AS1034	Haldex ASA. Requires a Gunite straight style clevis kit. 6.5" arm length only.
815811	AS1041	Haldex ASA. Requires a Gunite straight style clevis kit.
815812	AS1040	Haldex ASA. Requires a Gunite straight style clevis kit. 5.5" arm length only.
815812	AS1042	Haldex ASA. Requires a Gunite straight style clevis kit. 6.5" arm length only.

Industry P/N	Gunite Aftermarket P/N	Special Information
<b>Dana Corporation (continued)</b>		
815813	AS1033	Haldex ASA. Requires a Gunite straight style clevis kit.
815814	AS1036	Haldex ASA. Requires a Gunite straight style clevis kit.
815815	AS1036	Haldex ASA. Requires a Gunite .625" offset style clevis kit.
815816	AS1036	Haldex ASA. Requires a Gunite .625" offset style clevis kit.
815817	AS1038	Haldex ASA. Requires a Gunite straight style clevis kit.
815818	AS1038	Haldex ASA. Requires a Gunite .625" offset style clevis kit.
815819	AS1038	Haldex ASA. Requires a Gunite .625" offset style clevis kit.
815820	AS1032	Haldex ASA. Requires a Gunite straight style clevis kit.
815821	AS1040	Haldex ASA. Requires a Gunite straight style clevis kit.
815829	AS1041	Haldex ASA. Requires a Gunite straight style clevis kit.
<b>Euclid</b>		
E-051K	AS1031	Haldex ASA. Requires the use of a Gunite straight style clevis kit. 5.0" arm length only.
E-051K	AS1033	Haldex ASA. Requires the use of a Gunite straight style clevis kit. 6.0" arm length only.
E-070K	AS1041	Haldex ASA. Requires the use of a Gunite straight style clevis kit.
E-086K	AS1031	Requires the use of a Gunite clevis kit. 5.0" arm length only.
E-086K	AS1131	5.0" arm length only.
E-086K	AS1033	Requires the use of a Gunite clevis kit. 6.0" arm length only.
E-086K	AS1133	6.0" arm length only.
E-091K	AS1040	Requires the use of a Gunite clevis kit. 5.5" arm length only.
E-091K	AS1140	5.5" arm length only.
E-091K	AS1042	6.5" arm length only.
E-091K	AS1142	6.5" arm length only.
E-099K	AS1044	Haldex ASA. Requires the use of a Gunite straight style clevis kit.
E-108K	AS1032	Haldex ASA. Requires the use of a Gunite straight style clevis kit. 5.5" arm length only.
E-108K	AS1034	Haldex ASA. Requires the use of a Gunite straight style clevis kit. 6.5" arm length only.
E-108K1	AS1032	Haldex ASA. Requires the use of a Gunite straight style clevis kit. 5.5" arm length only.
E-108K1	AS1034	Haldex ASA. Requires the use of a Gunite straight style clevis kit. 6.5" arm length only.
E-111K	AS1031	Requires the use of a Gunite clevis kit. 5.0" arm length only.
E-111K	AS1131	5.0" arm length only.
E-111K	AS1033	Requires the use of a Gunite clevis kit. 6.0" arm length only.
E-111K	AS1133	6.0" arm length only.
E-112K	AS1032	Haldex ASA. Requires the use of a Gunite .625" offset style clevis kit.
E-112K1	AS1032	Haldex ASA. Requires the use of a Gunite .625" offset style clevis kit.
E-113K	AS1032	Haldex ASA. Requires the use of a Gunite .625" offset style clevis kit.
E-113K1	AS1032	Haldex ASA. Requires the use of a Gunite .625" offset style clevis kit.
E-114K	AS1036	Haldex ASA. Requires the use of a Gunite .625" offset style clevis kit.

**Replacement of other brands of slack adjusters should be done in axle sets.** Industry Part Numbers referencing more than a single interchange is the result of Gunite offering the option of ordering its Automatic Slack Adjusters with or without the clevis kit.

Features and Benefits  
Numerical Listings  
Axle Applications  
Obsolete Products  
Cross References

## CROSS REFERENCES

### INDUSTRY TO GUNITE

Industry P/N	Gunite Aftermarket P/N	Special Information
<b>Euclid (continued)</b>		
E-114K1	AS1036	Haldex ASA. Requires the use of a Gunite .625" offset style clevis kit.
E-115K	AS1036	Haldex ASA. Requires the use of a Gunite .625" offset style clevis kit.
E-115K1	AS1036	Haldex ASA. Requires the use of a Gunite .625" offset style clevis kit.
E-128K	AS1036	Haldex ASA. Requires the use of a Gunite straight style clevis kit.
E-128K1	AS1036	Haldex ASA. Requires the use of a Gunite straight style clevis kit.
E-129K	AS1031	Requires the use of a Gunite clevis kit. 5.0" arm length only.
E-129K	AS1131	5.0" arm length only.
E-129K	AS1033	Requires the use of a Gunite clevis kit. 6.0" arm length only.
E-129K	AS1133	6.0" arm length only.
E-130K	AS1031	Haldex ASA. Requires the use of a Gunite straight style clevis kit. 5.0" arm length only.
E-130K	AS1033	Haldex ASA. Requires the use of a Gunite straight style clevis kit. 6.0" arm length only.
E-135K	AS1032	Haldex ASA. Requires the use of a Gunite straight style clevis kit. 5.5" arm length only.
E-135K	AS1034	Haldex ASA. Requires the use of a Gunite straight style clevis kit. 6.5" arm length only.
E-146K	AS1039	Haldex ASA. Requires the use of a Gunite straight style clevis kit. 5.0" arm length only.
E-146K	AS1041	Haldex ASA. Requires the use of a Gunite straight style clevis kit. 6.0" arm length only.
E-149K	AS1039	Haldex ASA. Requires the use of a Gunite straight style clevis kit. 5.0" arm length only.
E-149K	AS1041	Haldex ASA. Requires the use of a Gunite straight style clevis kit. 6.0" arm length only.
E-150K	AS1040	Haldex ASA. Requires the use of a Gunite straight style clevis kit.
E-167K	AS1039	Haldex ASA. Requires the use of a Gunite straight style clevis kit. 5.0" arm length only.
E-167K	AS1041	Haldex ASA. Requires the use of a Gunite straight style clevis kit. 6.0" arm length only.
E-167K1	AS1039	Haldex ASA. Requires the use of a Gunite straight style clevis kit. 5.0" arm length only.
E-167K1	AS1041	Haldex ASA. Requires the use of a Gunite straight style clevis kit. 6.0" arm length only.
E-168K	AS1040	Haldex ASA. Requires the use of a Gunite straight style clevis kit. 5.5" arm length only.
E-168K	AS1042	Haldex ASA. Requires the use of a Gunite straight style clevis kit. 6.5" arm length only.
E-168K1	AS1040	Haldex ASA. Requires the use of a Gunite straight style clevis kit. 5.5" arm length only.
E-168K1	AS1042	Haldex ASA. Requires the use of a Gunite straight style clevis kit. 6.5" arm length only.
E-211K	AS1031	Requires the use of a Gunite clevis kit. 5.0" arm length only.
E-211K	AS1131	5.0" arm length only.
E-211K	AS1033	Requires the use of a Gunite clevis kit. 6.0" arm length only.
E-211K	AS1133	6.0" arm length only.
E-215K	AS1040	Haldex ASA. Requires the use of a Gunite straight style clevis kit. 5.5" arm length only.
E-215K	AS1042	Haldex ASA. Requires the use of a Gunite straight style clevis kit. 6.5" arm length only.
E-218K	AS1044	Haldex ASA. Requires the use of a Gunite straight style clevis kit.
E-229K	AS1040	Haldex ASA. Requires the use of a Gunite straight style clevis kit. 5.5" arm length only.

Industry P/N	Gunite Aftermarket P/N	Special Information
<b>Euclid (continued)</b>		
E-229K	AS1042	Haldex ASA. Requires the use of a Gunite straight style clevis kit. 6.5" arm length only.
E-230K	AS1031	Haldex ASA. Requires the use of a Gunite straight style clevis kit. 5.0" arm length only.
E-230K	AS1033	Haldex ASA. Requires the use of a Gunite straight style clevis kit. 6.0" arm length only.
E-231K	AS1031	Haldex ASA. Requires the use of a Gunite straight style clevis kit. 5.0" arm length only.
E-231K	AS1033	Haldex ASA. Requires the use of a Gunite straight style clevis kit. 6.0" arm length only.
E-232K	AS1032	Haldex ASA. Requires the use of a Gunite straight style clevis kit. 5.5" arm length only.
E-232K	AS1034	Haldex ASA. Requires the use of a Gunite straight style clevis kit. 6.5" arm length only.
E-233K	AS1032	Haldex ASA. Requires the use of a Gunite straight style clevis kit. 5.5" arm length only.
E-233K	AS1034	Haldex ASA. Requires the use of a Gunite straight style clevis kit. 6.5" arm length only.
E-234K	AS1039	Haldex ASA. Requires the use of a Gunite straight style clevis kit. 5.0" arm length only.
E-234K	AS1041	Haldex ASA. Requires the use of a Gunite straight style clevis kit. 6.0" arm length only.
E-235K	AS1039	Haldex ASA. Requires the use of a Gunite straight style clevis kit. 5.0" arm length only.
E-235K	AS1041	Haldex ASA. Requires the use of a Gunite straight style clevis kit. 6.0" arm length only.
E-236K	AS1040	Haldex ASA. Requires the use of a Gunite straight style clevis kit. 5.5" arm length only.
E-236K	AS1042	Haldex ASA. Requires the use of a Gunite straight style clevis kit. 6.5" arm length only.
E-237K	AS1040	Haldex ASA. Requires the use of a Gunite straight style clevis kit. 5.5" arm length only.
E-237K	AS1042	Haldex ASA. Requires the use of a Gunite straight style clevis kit. 6.5" arm length only.
E-238K	AS1032	Haldex ASA. Requires the use of a Gunite straight style clevis kit. 5.5" arm length only.
E-238K	AS1034	Haldex ASA. Requires the use of a Gunite straight style clevis kit. 6.5" arm length only.
E-239K	AS1031	Haldex ASA. Requires the use of a Gunite straight style clevis kit. 5.0" arm length only.
E-239K	AS1033	Haldex ASA. Requires the use of a Gunite straight style clevis kit. 6.0" arm length only.
E-240K	AS1040	Haldex ASA. Requires the use of a Gunite straight style clevis kit. 5.5" arm length only.
E-240K	AS1042	Haldex ASA. Requires the use of a Gunite straight style clevis kit. 6.5" arm length only.
E-241K	AS1039	Haldex ASA. Requires the use of a Gunite straight style clevis kit. 5.0" arm length only.
E-241K	AS1041	Haldex ASA. Requires the use of a Gunite straight style clevis kit. 6.0" arm length only.
E-247K	AS1031	Haldex ASA. Requires the use of a Gunite straight style clevis kit. 5.0" arm length only.
E-247K	AS1033	Haldex ASA. Requires the use of a Gunite straight style clevis kit. 6.0" arm length only.
E-294K	AS1032	Requires the use of a Gunite clevis kit. 5.5" arm length only.
E-294K	AS1132	5.5" arm length only.
E-294K	AS1034	6.5" arm length only.
E-294K	AS1134	6.5" arm length only.
E-318K	AS1031	Requires the use of a Gunite clevis kit. 5.0" arm length only.
E-318K	AS1131	5.0" arm length only.
E-318K	AS1033	Requires the use of a Gunite clevis kit. 6.0" arm length only.

**Replacement of other brands of slack adjusters should be done in axle sets.** Industry Part Numbers referencing more than a single interchange is the result of Gunite offering the option of ordering its Automatic Slack Adjusters with or without the clevis kit.

# CROSS REFERENCES

## INDUSTRY TO GUNITE

Industry P/N	Gunite Aftermarket P/N	Special Information
<b>Euclid (continued)</b>		
E-318K	AS1133	6.0" arm length only.
E-319K	AS1038	Requires the use of a Gunite clevis kit.
E-319K	AS1138	
E-325K	AS1036	Requires the use of a Gunite clevis kit.
E-325K	AS1136	
E-10779A	AS1040	Crewson Industries ASA. Requires the use of either AS3000 or AS3016 clevis kits.
E-10779A	AS1140	Crewson Industries ASA.
E-10780A	AS1032	Crewson Industries ASA. Requires the use of either AS3000 or AS3016 clevis kits.
E-10780A	AS1132	Crewson Industries ASA.
E-10781A	AS1041	Crewson Industries ASA. Requires the use of either AS3000 or AS3016 clevis kits.
E-10781A	AS1141	Crewson Industries ASA.
E-10782A	AS1033	Crewson Industries ASA. Requires the use of either AS3000 or AS3016 clevis kits.
E-10782A	AS1133	Crewson Industries ASA.
E-10783A	AS1044	Crewson Industries ASA. Requires the use of either AS3000 or AS3016 clevis kits.
E-10783A	AS1144	Crewson Industries ASA.
E-10784A	AS1036	Crewson Industries ASA. Requires the use of either AS3000 or AS3016 clevis kits.
E-10784A	AS1136	Crewson Industries ASA.
E-10785A	AS1040	Crewson Industries ASA. Requires the use of either AS3000 or AS3016 clevis kits.
E-10785A	AS1140	Crewson Industries ASA.
E-10786A	AS1032	Crewson Industries ASA. Requires the use of either AS3000 or AS3016 clevis kits.
E-10786A	AS1132	Crewson Industries ASA.
E-10787A	AS1044	Crewson Industries ASA. Requires the use of either AS3000 or AS3016 clevis kits.
E-10787A	AS1144	Crewson Industries ASA.
E-10788A	AS1041	Crewson Industries ASA. Requires the use of either AS3000 or AS3016 clevis kits.
E-10788A	AS1141	Crewson Industries ASA.
E-10789A	AS1033	Crewson Industries ASA. Requires the use of either AS3000 or AS3016 clevis kits.
E-10789A	AS1133	Crewson Industries ASA.
E-10892	AS1032	Requires the use of either AS3000 or AS3001 clevis kits.
E-10892	AS1132	
E-10893	AS1040	Requires the use of either AS3000 or AS3001 clevis kits.
E-10893	AS1140	
E-11395	AS1036	Requires the use of either AS3001 or AS3017 clevis kits.
E-11395	AS1136	
E-11396	AS1038	Requires the use of either AS3001 or AS3017 clevis kits.
E-11396	AS1138	
E-11398	AS1032	Requires the use of either AS3000 or AS3016 clevis kits.
E-11398	AS1132	
E-11399	AS1033	Requires the use of either AS3000 or AS3016 clevis kits.
E-11399	AS1133	
E-11400	AS1040	Requires the use of either AS3000 or AS3016 clevis kits.

Industry P/N	Gunite Aftermarket P/N	Special Information
<b>Euclid (continued)</b>		
E-11400	AS1140	
E-11401	AS1040	Requires the use of either AS3000 or AS3016 clevis kits.
E-11401	AS1140	
E-11402	AS1041	Requires the use of either AS3000 or AS3016 clevis kits.
E-11402	AS1141	
E-11403	AS1042	Requires the use of either AS3000 or AS3016 clevis kits.
E-11403	AS1142	
E-11404	AS1040	Requires the use of either AS3000 or AS3016 clevis kits.
E-11404	AS1140	
E-11405	AS1043	Requires the use of either AS3000 or AS3016 clevis kits.
E-11405	AS1143	
E-11406	AS1044	Requires the use of either AS3000 or AS3016 clevis kits.
E-11406	AS1144	
E-11407	AS1038	Requires the use of either AS3000 or AS3016 clevis kits.
E-11407	AS1138	
E-11408	AS1038	Requires the use of either AS3000 or AS3016 clevis kits.
E-11408	AS1138	
E-11409	AS1032	Requires the use of either AS3000 or AS3016 clevis kits.
E-11409	AS1132	
E-11410	AS1032	Requires the use of either AS3000 or AS3016 clevis kits.
E-11410	AS1132	
E-11411	AS1032	Requires the use of either AS3000 or AS3016 clevis kits.
E-11411	AS1132	
E-11412	AS1032	Requires the use of either AS3000 or AS3016 clevis kits.
E-11412	AS1132	
E-11415	AS1040	Requires the use of either AS3000 or AS3016 clevis kits.
E-11415	AS1140	
E-11416	AS1040	Requires the use of either AS3000 or AS3016 clevis kits.
E-11416	AS1140	
E-11417	AS1040	Requires the use of either AS3000 or AS3016 clevis kits.
E-11417	AS1140	
E-11418	AS1040	Requires the use of either AS3000 or AS3016 clevis kits.
E-11418	AS1140	
E-11419	R802462	AS1040
E-11419	R802462	AS1140
E-11420	AS1040	Requires the use of either AS3000 or AS3016 clevis kits.
E-11420	AS1140	
E-11421	AS1041	Requires the use of either AS3000 or AS3016 clevis kits.
E-11421	AS1141	
E-11422	AS1041	Requires the use of either AS3000 or AS3016 clevis kits.
E-11422	AS1141	
E-11423	AS1041	Requires the use of either AS3000 or AS3016 clevis kits.
E-11423	AS1141	
E-11424	AS1041	Requires the use of either AS3000 or AS3016 clevis kits.

**Replacement of other brands of slack adjusters should be done in axle sets.** Industry Part Numbers referencing more than a single interchange is the result of Gunite offering the option of ordering its Automatic Slack Adjusters with or without the clevis kit.

Features and Benefits  
Numerical Listings  
Axle Applications  
Obsolete Products  
Cross References



## CROSS REFERENCES

### INDUSTRY TO GUNITE

Industry P/N	Gunite Aftermarket P/N	Special Information
<b>Euclid (continued)</b>		
E-11424	AS1141	
E-11425	AS1032	Requires the use of either AS3000 or AS3016 clevis kits.
E-11425	AS1032	
E-11426	AS1032	Requires the use of either AS3000 or AS3016 clevis kits.
E-11426	AS1132	
E-11873	AS1042	Crewson Industries ASA. Requires the use of either AS3000 or AS3016 clevis kits.
E-11875	AS1045	Crewson Industries ASA. Requires the use of either AS3000 or AS3016 clevis kits.
E-11877	AS1038	Crewson Industries ASA. Requires the use of either AS3001 or AS3017 clevis kits.
E-11877	AS1138	Crewson Industries ASA.
E-11879	AS1038	Crewson Industries ASA. Requires the use of either AS3001 or AS3017 clevis kits.
E-11879	AS1138	Crewson Industries ASA.
E-11880	AS1036	Crewson Industries ASA. Requires the use of either AS3001 or AS3017 clevis kits.
E-11880	AS1136	Crewson Industries ASA.
E-11902	AS1042	Requires the use of either AS3000 or AS3016 clevis kits.
E-11902	AS1142	
E-6900	AS1036	Requires the use of either AS3000 or AS3001 clevis kits.
E-6900	AS1136	
E-6900A	AS1036	Haldex ASA. Requires the use of either AS3000 or AS3001 clevis kits.
E-6900A	AS1136	Haldex ASA.
E-6901	AS1036	Requires the use of either AS3000 or AS3001 clevis kits.
E-6901	AS1136	
E-6902	AS1038	Requires the use of either AS3000 or AS3016 clevis kits.
E-6902	AS1138	
E-6902A	AS1038	Haldex ASA. Requires the use of either AS3000 or AS3001 clevis kits.
E-6902A	AS1138	Haldex ASA.
E-6903	AS1032	Requires the use of either AS3000 or AS3016 clevis kits.
E-6903	AS1132	
E-6903A	AS1032	Haldex ASA. Requires the use of either AS3000 or AS3001 clevis kits.
E-6903A	AS1132	Haldex ASA.
E-6904	AS1039	Requires the use of a Gunite clevis kit. 5.0" arm length only.
E-6904	AS1139	5.0" arm length only.
E-6904	AS1041	Requires the use of a Gunite clevis kit. 6.0" arm length only.
E-6904	AS1141	6.0" arm length only.
E-6905	AS1040	Requires the use of either AS3000 or AS3016 clevis kits.
E-6905	AS1140	
E-6905A	AS1040	Haldex ASA. Requires the use of either AS3000 or AS3001 clevis kits.
E-6905A	AS1140	Haldex ASA.
E-6906	AS1036	Requires the use of either AS3002 or AS3003 clevis kits.
E-6906A	AS1036	Haldex ASA. Requires the use of either AS3002 or AS3003 clevis kits.
E-6907	AS1036	Requires the use of either AS3002 or AS3003 clevis kits.

Industry P/N	Gunite Aftermarket P/N	Special Information
<b>Euclid (continued)</b>		
E-6907A	AS1036	Haldex ASA. Requires the use of either AS3002 or AS3003 clevis kits.
E-6908	AS1032	Requires the use of a Gunite clevis kit. 5.5" arm length only.
E-6908	AS1132	5.5" arm length only.
E-6909	AS1032	Requires the use of a Gunite clevis kit. 5.5" arm length only.
E-6909	AS1132	5.5" arm length only.
E-6914	AS1033	Haldex ASA. Requires the use of either AS3000 or AS3001 clevis kits.
E-6914A	AS1033	Haldex ASA. Requires the use of either AS3000 or AS3001 clevis kits.
E-6915	AS1032	Haldex ASA. Requires the use of either AS3000 or AS3001 clevis kits. 5.5" arm length only.
E-6915	AS1132	Haldex ASA. Requires the use of either AS3000 or AS3001 clevis kits. 6.5" arm length only.
E-6918	AS1041	Haldex ASA. Requires the use of either AS3000 or AS3001 clevis kits.
E-6918	AS1141	Haldex ASA.
E-6918A	AS1041	Haldex ASA. Requires the use of either AS3000 or AS3001 clevis kits.
E-6918A	AS1141	Haldex ASA.
E-6919	AS1040	Haldex ASA. Requires the use of either AS3000 or AS3001 clevis kits. 5.5" arm length only.
E-6919	AS1140	Haldex ASA. 5.5" arm length only.
E-6919	AS1042	Haldex ASA. Requires the use of either AS3000 or AS3001 clevis kits. 6.5" arm length only.
E-6919	AS1142	Haldex ASA. 6.5" arm length only.
E-6919A	AS1040	Haldex ASA. Requires the use of either AS3000 or AS3001 clevis kits. 5.5" arm length only.
E-6919A	AS1140	Haldex ASA. 5.5" arm length only.
E-6919A	AS1042	Haldex ASA. Requires the use of either AS3000 or AS3001 clevis kits. 6.5" arm length only.
E-6919A	AS1142	Haldex ASA. 6.5" arm length only.
E-6920	AS1040	Haldex ASA. Requires the use of either AS3000 or AS3001 clevis kits. 5.5" arm length only.
E-6920	AS1042	Haldex ASA. Requires the use of either AS3000 or AS3001 clevis kits. 6.5" arm length only.
E-6923	AS1031	Haldex ASA. Requires the use of either AS3000 or AS3001 clevis kits. 5.0" arm length only.
E-6923	AS1033	Haldex ASA. Requires the use of either AS3000 or AS3001 clevis kits. 6.0" arm length only.
E-6923A	AS1031	Haldex ASA. Requires the use of either AS3000 or AS3001 clevis kits. 5.0" arm length only.
E-6923A	AS1033	Haldex ASA. Requires the use of either AS3000 or AS3001 clevis kits. 6.0" arm length only.
E-6923B	AS1031	Haldex ASA. Requires the use of either AS3000 or AS3001 clevis kits. 5.0" arm length only.
E-6923B	AS1033	Haldex ASA. Requires the use of either AS3000 or AS3001 clevis kits. 6.0" arm length only.
E-6924	AS1032	Haldex ASA. Requires the use of either AS3000 or AS3001 clevis kits. 5.5" arm length only.
E-6924	AS1034	Haldex ASA. Requires the use of either AS3000 or AS3001 clevis kits. 6.5" arm length only.
E-6924A	AS1032	Haldex ASA. Requires the use of either AS3000 or AS3001 clevis kits. 5.5" arm length only.
E-6924A	AS1034	Haldex ASA. Requires the use of either AS3000 or AS3001 clevis kits. 6.5" arm length only.
E-6924B	AS1032	Haldex ASA. Requires the use of either AS3000 or AS3001 clevis kits. 5.5" arm length only.
E-6924B	AS1034	Haldex ASA. Requires the use of either AS3000 or AS3001 clevis kits. 6.5" arm length only.

**Replacement of other brands of slack adjusters should be done in axle sets.** Industry Part Numbers referencing more than a single interchange is the result of Gunite offering the option of ordering its Automatic Slack Adjusters with or without the clevis kit.

# CROSS REFERENCES

## INDUSTRY TO GUNITE

Industry P/N	Gunite Aftermarket P/N	Special Information
<b>Euclid (continued)</b>		
E-6925	AS1039	Haldex ASA. Requires the use of either AS3000 or AS3001 clevis kits. 5.0" arm length only.
E-6925	AS1041	Haldex ASA. Requires the use of either AS3000 or AS3001 clevis kits. 6.0" arm length only.
E-6925A	AS1039	Haldex ASA. Requires the use of either AS3000 or AS3001 clevis kits. 5.0" arm length only.
E-6925A	AS1041	Haldex ASA. Requires the use of either AS3000 or AS3001 clevis kits. 6.0" arm length only.
E-6925B	AS1039	Haldex ASA. Requires the use of either AS3000 or AS3001 clevis kits. 5.0" arm length only.
E-6925B	AS1041	Haldex ASA. Requires the use of either AS3000 or AS3001 clevis kits. 6.0" arm length only.
E-6926	AS1040	Requires the use of a Gunite clevis kit.
E-6926	AS1140	
E-6927	AS1040	Haldex ASA. Requires the use of either AS3000 or AS3001 clevis kits. 5.5" arm length only.
E-6927	AS1042	Haldex ASA. Requires the use of either AS3000 or AS3001 clevis kits. 6.5" arm length only.
E-6927A	AS1040	Haldex ASA. Requires the use of either AS3000 or AS3001 clevis kits. 5.5" arm length only.
E-6927A	AS1042	Haldex ASA. Requires the use of either AS3000 or AS3001 clevis kits. 6.5" arm length only.
E-6927B	AS1040	Haldex ASA. Requires the use of either AS3000 or AS3001 clevis kits. 5.5" arm length only.
E-6927B	AS1042	Haldex ASA. Requires the use of either AS3000 or AS3001 clevis kits. 6.5" arm length only.
E-6936	AS1033	Haldex ASA. Requires the use of either AS3000 or AS3001 clevis kits.
E-6936	AS1133	Haldex ASA.
E-6937	AS1033	Requires the use of a Gunite clevis kit.
E-6937	AS1133	
E-6938	AS1031	Requires the use of a Gunite clevis kit. 5.0" arm length only.
E-6938	AS1131	5.0" arm length only.
E-6938	AS1033	Requires the use of a Gunite clevis kit. 6.0" arm length only.
E-6938	AS1133	6.0" arm length only.
E-6939	AS1033	Haldex ASA. Requires the use of either AS3000 or AS3001 clevis kits.
E-6939	AS1133	Haldex ASA.
E-6940	AS1032	Haldex ASA. Requires the use of either AS3000 or AS3001 clevis kits.
E-6940	AS1132	Haldex ASA.
E-6941	AS1032	Haldex ASA. Requires the use of either AS3000 or AS3001 clevis kits.
E-6941	AS1132	Haldex ASA.
E-6942	AS1041	Haldex ASA. Requires the use of either AS3000 or AS3001 clevis kits.
E-6943	AS1041	Haldex ASA. Requires the use of either AS3000 or AS3001 clevis kits.
E-6944	AS1040	Haldex ASA. Requires the use of either AS3000 or AS3001 clevis kits.
E-6944	AS1140	Haldex ASA.
E-6945	AS1040	Requires the use of a Gunite clevis kit.
E-6945	AS1140	
E-6946	AS1044	Haldex ASA. Requires the use of either AS3000 or AS3001 clevis kits.
E-6947	AS1043	Haldex ASA. Requires the use of either AS3000 or AS3001 clevis kits.

Industry P/N	Gunite Aftermarket P/N	Special Information
<b>Euclid (continued)</b>		
E-6948	AS1044	Requires the use of a Gunite clevis kit.
E-6948	AS1144	
E-6949	AS1031	Requires the use of a Gunite clevis kit.
E-6949	AS1131	
E-6981	AS1038	Haldex ASA. Requires the use of either AS3002 or AS3003 clevis kits.
E-6982	AS1038	Haldex ASA. Requires the use of either AS3002 or AS3003 clevis kits.
E-6987	AS1036	Requires the use of a Gunite clevis kit.
E-6987	AS1136	
E-6987A	AS1036	Crewson Industries ASA. Requires the use of AS3001 or AS3016 clevis kit.
E-6987A	AS1136	Crewson Industries ASA.
E-6988	AS1036	Requires the use of a Gunite clevis kit.
E-6988	AS1036	Requires the use of a Gunite clevis kit.
E-6988A	AS1036	Crewson Industries ASA. Requires the use of AS3003 clevis kit.
E-6989	AS1038	Requires the use of a Gunite clevis kit.
E-6989A	AS1038	Crewson Industries ASA. Requires the use of AS3003 clevis kit.
E-6989A	AS1138	
E-6990	AS1038	Requires the use of a Gunite clevis kit.
E-6990	AS1138	
E-6990A	AS1038	Crewson Industries ASA. Requires the use of AS3003 clevis kit.
E-6990A	AS1138	
E-6991	AS1031	Requires the use of a Gunite clevis kit. 5.0" arm length only.
E-6991	AS1131	5.0" arm length only.
E-6991	AS1033	Requires the use of a Gunite clevis kit. 6.0" arm length only.
E-6991	AS1133	6.0" arm length only.
E-6991A	AS1031	Crewson Industries ASA. 5.0" arm length only. Requires the use of either AS3000 or AS3016 clevis kits.
E-6991A	AS1131	Crewson Industries ASA. 5.0" arm length only.
E-6991A	AS1033	Crewson Industries ASA. 6.0" arm length only. Requires the use of either AS3000 or AS3016 clevis kits.
E-6991A	AS1133	Crewson Industries ASA. 6.0" arm length only.
E-6992	AS1032	Requires the use of a Gunite clevis kit. 5.5" arm length only.
E-6992	AS1132	5.5" arm length only.
E-6992	AS1034	6.5" arm length only.
E-6992	AS1134	6.5" arm length only.
E-6992A	AS1032	Crewson Industries ASA. 5.5" arm length only. Requires the use of either AS3000 or AS3016 clevis kits.
E-6992A	AS1132	Crewson Industries ASA. 5.5" arm length only.
E-6992A	AS1034	Crewson Industries ASA. 6.5" arm length only. Requires the use of either AS3000 or AS3016 clevis kits.
E-6992A	AS1134	Crewson Industries ASA. 6.5" arm length only.
E-6993	AS1039	Requires the use of a Gunite clevis kit. 5.0" arm length only.
E-6993	AS1139	5.0" arm length only.

**Replacement of other brands of slack adjusters should be done in axle sets.** Industry Part Numbers referencing more than a single interchange is the result of Gunite offering the option of ordering its Automatic Slack Adjusters with or without the clevis kit.

## CROSS REFERENCES

### INDUSTRY TO GUNITE

Industry P/N	Gunite Aftermarket P/N	Special Information
<b>Euclid (continued)</b>		
E-6993	AS1041	Requires the use of a Gunite clevis kit. 6.0" length only.
E-6993	AS1141	6.0" arm length only.
E-6993A	AS1039	Crewson Industries ASA. 5.0" arm length only. Requires the use of either AS3000 or AS3016 clevis kits.
E-6993A	AS1139	Crewson Industries ASA. 5.0" arm length only.
E-6993A	AS1041	Crewson Industries ASA. 6.0" arm length only. Requires the use of either AS3000 or AS3016 clevis kits.
E-6993A	AS1141	Crewson Industries ASA. 6.0" arm length only.
E-6994	AS1040	Requires the use of a Gunite clevis kit. 5.5" arm length only.
E-6994	AS1140	5.5" arm length only.
E-6994	AS1042	6.5" arm length only.
E-6994	AS1142	6.5" arm length only.
E-6994A	AS1040	Crewson Industries ASA. 5.5" arm length only. Requires the use of either AS3000 or AS3016 clevis kits.
E-6994A	AS1140	Crewson Industries ASA. 5.5" arm length only.
E-6994A	AS1042	Crewson Industries ASA. 6.5" arm length only. Requires the use of either AS3000 or AS3016 clevis kits.
E-6994A	AS1142	Crewson Industries ASA. 6.5" arm length only.
E-6995	AS1044	Requires the use of a Gunite clevis kit. 6.0" arm length only.
E-6995	AS1144	6.0" arm length only.
E-6995A	AS1044	Crewson Industries ASA. 6.0" arm length only. Requires the use of either AS3000 or AS3016 clevis kits.
E-6995A	AS1144	Crewson Industries ASA. 6.0" arm length only.
E-6996	AS1043	Requires the use of a Gunite clevis kit. 5.5" arm length only.
E-6996	AS1143	5.5" arm length only.
E-6996	AS1045	6.5" arm length only.
E-6996	AS1145	6.5" arm length only.
E-6996A	AS1043	Crewson Industries ASA. 5.5" arm length only. Requires the use of either AS3000 or AS3016 clevis kits.
E-6996A	AS1143	Crewson Industries ASA. 5.5" arm length only.
E-6996A	AS1045	Crewson Industries ASA. 6.5" arm length only. Requires the use of either AS3000 or AS3016 clevis kits.
E-6996A	AS1145	Crewson Industries ASA. 6.5" arm length only.
<b>Haldex Brake Systems</b>		
400-10001	AS1036	Requires a Gunite straight style clevis kit.
400-10002	AS1036	Requires a Gunite .625" offset style clevis kit.
400-10003	AS1036	Requires a Gunite .625" offset style clevis kit.
400-10004	AS1038	Requires a Gunite straight style clevis kit.
400-10005	AS1032	Requires a Gunite straight style clevis kit.
400-10006	AS1032	Requires a Gunite .625" offset style clevis kit.
400-10007	AS1032	Requires a Gunite .625" offset style clevis kit.
400-10008	AS1040	Requires a Gunite straight style clevis kit.
400-10011	AS1040	Requires a Gunite straight style clevis kit. 5.5" arm length only.
400-10011	AS1042	Requires a Gunite straight style clevis kit. 6.5" arm length only.
400-10012	AS1032	Requires a Gunite straight style clevis kit. 5.5" arm length only.
400-10012	AS1034	Requires a Gunite straight style clevis kit. 6.5" arm length only.

Industry P/N	Gunite Aftermarket P/N	Special Information
<b>Haldex Brake Systems (continued)</b>		
400-10040	AS1038	Requires a Gunite .625" offset style clevis kit.
400-10041	AS1038	Requires a Gunite .625" offset style clevis kit.
400-10067	AS1039	Requires a Gunite straight style clevis kit. 5.0" arm length only.
400-10067	AS1041	Requires a Gunite straight style clevis kit. 6.0" arm length only.
400-10070	AS1040	Requires a Gunite straight style clevis kit.
400-10071	AS1032	Requires a Gunite straight style clevis kit.
400-10072	AS1036	Requires a Gunite straight style clevis kit.
400-10073	AS1038	Requires a Gunite straight style clevis kit.
400-10100	AS1039	Requires a Gunite straight style clevis kit. 5.0" arm length only.
400-10100	AS1041	Requires a Gunite straight style clevis kit. 6.0" arm length only.
400-10101	AS1040	Requires a Gunite straight style clevis kit. 5.5" arm length only.
400-10101	AS1042	Requires a Gunite straight style clevis kit. 6.5" arm length only.
400-10102	AS1031	Requires a Gunite straight style clevis kit. 5.0" arm length only.
400-10102	AS1033	Requires a Gunite straight style clevis kit. 6.0" arm length only.
400-10103	AS1032	Requires a Gunite straight style clevis kit. 5.5" arm length only.
400-10103	AS1034	Requires a Gunite straight style clevis kit. 6.5" arm length only.
400-10104	AS1041	Requires a Gunite straight style clevis kit.
400-10105	AS1033	Requires a Gunite straight style clevis kit.
400-10106	AS1040	Requires a Gunite straight style clevis kit. 5.5" arm length only.
400-10106	AS1042	Requires a Gunite straight style clevis kit. 6.5" arm length only.
400-10140	AS1039	Requires a Gunite straight style clevis kit. 5.0" arm length only.
400-10140	AS1041	Requires a Gunite straight style clevis kit. 6.0" arm length only.
400-10141	AS1040	Requires a Gunite straight style clevis kit.
400-10142	AS1031	Requires a Gunite straight style clevis kit. 5.0" arm length only.
400-10142	AS1033	Requires a Gunite straight style clevis kit. 6.0" arm length only.
400-10143	AS1032	Requires a Gunite straight style clevis kit. 5.5" arm length only.
400-10143	AS1034	Requires a Gunite straight style clevis kit. 6.5" arm length only.
400-10144	AS1041	Requires a Gunite straight style clevis kit.
400-10145	AS1033	Requires a Gunite straight style clevis kit.
400-10146	AS1040	Requires a Gunite straight style clevis kit. 5.5" arm length only.
400-10146	AS1042	Requires a Gunite straight style clevis kit. 6.5" arm length only.
400-10155	AS1032	Requires a Gunite straight style clevis kit.
400-10156	AS1040	Requires a Gunite straight style clevis kit.
400-10200	AS1041	Requires a Gunite straight style clevis kit.
400-10201	AS1040	Requires a Gunite straight style clevis kit.
400-10202	AS1033	Requires a Gunite straight style clevis kit.
400-10203	AS1032	Requires a Gunite straight style clevis kit.
400-10204	AS1044	Requires a Gunite straight style clevis kit.

**Replacement of other brands of slack adjusters should be done in axle sets.** Industry Part Numbers referencing more than a single interchange is the result of Gunite offering the option of ordering its Automatic Slack Adjusters with or without the clevis kit.



# CROSS REFERENCES

## INDUSTRY TO GUNITE

Industry P/N	Gunite Aftermarket P/N	Special Information
<b>Haldex Brake Systems (continued)</b>		
400-10205	AS1043	Requires a Gunite straight style clevis kit.
400-10206	AS1033	Requires a Gunite straight style clevis kit.
400-10207	AS1031	Requires a Gunite straight style clevis kit. 5.0" arm length only.
400-10207	AS1033	Requires a Gunite straight style clevis kit. 6.0" arm length only.
400-10211	AS1040	Requires a Gunite straight style clevis kit.
400-10212	AS1041	Requires a Gunite straight style clevis kit.
400-10213	AS1043	Requires a Gunite straight style clevis kit.
400-10214	AS1044	Requires a Gunite straight style clevis kit.
400-10215	AS1032	Requires a Gunite straight style clevis kit.
400-10216	AS1033	Requires a Gunite straight style clevis kit.
400-20211	AS1040	Requires a Gunite straight style clevis kit.
400-20212	AS1041	Requires a Gunite straight style clevis kit.
400-20213	AS1043	Requires a Gunite straight style clevis kit.
400-20214	AS1044	Requires a Gunite straight style clevis kit.
400-20215	AS1032	Requires a Gunite straight style clevis kit.
400-20216	AS1033	Requires a Gunite straight style clevis kit.
409-10011	AS1033	Requires a Gunite straight style clevis kit.
409-10051	AS1031	Requires a Gunite straight style clevis kit. 5.0" arm length only.
409-10051	AS1033	Requires a Gunite straight style clevis kit. 6.0" arm length only.
409-10070	AS1041	Requires a Gunite straight style clevis kit.
409-10071	AS1033	Requires a Gunite straight style clevis kit.
409-10085	AS1032	Requires a Gunite straight style clevis kit.
409-10086	AS1031	Requires a Gunite straight style clevis kit. 5.0" arm length only.
409-10086	AS1033	Requires a Gunite straight style clevis kit. 6.0" arm length only.
409-10091	AS1040	Requires a Gunite straight style clevis kit. 5.5" arm length only.
409-10091	AS1042	Requires a Gunite straight style clevis kit. 6.5" arm length only.
409-10093	AS1039	Requires a Gunite straight style clevis kit. 5.0" arm length only.
409-10093	AS1041	Requires a Gunite straight style clevis kit. 6.0" arm length only.
409-10094	AS1040	Requires a Gunite straight style clevis kit. 5.5" arm length only.
409-10094	AS1042	Requires a Gunite straight style clevis kit. 6.5" arm length only.
409-10099	AS1044	Requires a Gunite straight style clevis kit.
409-10101	AS1032	Requires a Gunite straight style clevis kit. 5.5" arm length only.
409-10101	AS1034	Requires a Gunite straight style clevis kit. 6.5" arm length only.
409-10102	AS1031	Requires a Gunite straight style clevis kit. 5.0" arm length only.
409-10102	AS1033	Requires a Gunite straight style clevis kit. 6.0" arm length only.
409-10108	AS1032	Requires a Gunite straight style clevis kit. 5.5" arm length only.
409-10108	AS1034	Requires a Gunite straight style clevis kit. 6.5" arm length only.
409-10112	AS1032	Requires a Gunite .625" offset style clevis kit.

Industry P/N	Gunite Aftermarket P/N	Special Information
<b>Haldex Brake Systems (continued)</b>		
409-10113	AS1032	Requires a Gunite .625" offset style clevis kit.
409-10114	AS1036	Requires a Gunite .625" offset style clevis kit.
409-10115	AS1036	Requires a Gunite .625" offset style clevis kit.
409-10120	AS1036	Requires a Gunite .625" offset style clevis kit.
409-10121	AS1036	Requires a Gunite .625" offset style clevis kit.
409-10124	AS1033	Requires a Gunite straight style clevis kit.
409-10125	AS1039	Requires a Gunite straight style clevis kit. 5.0" arm length only.
409-10125	AS1041	Requires a Gunite straight style clevis kit. 6.0" arm length only.
409-10126	AS1040	Requires a Gunite straight style clevis kit. 5.5" arm length only.
409-10126	AS1042	Requires a Gunite straight style clevis kit. 6.5" arm length only.
409-10128	AS1036	Requires a Gunite straight style clevis kit. 5.5" arm length only.
409-10130	AS1031	Requires a Gunite straight style clevis kit. 5.0" arm length only.
409-10130	AS1033	Requires a Gunite straight style clevis kit. 6.0" arm length only.
409-10134	AS1032	Requires a Gunite straight style clevis kit. 5.5" arm length only.
409-10134	AS1034	Requires a Gunite straight style clevis kit. 6.5" arm length only.
409-10135	AS1032	Requires a Gunite straight style clevis kit. 5.5" arm length only.
409-10135	AS1034	Requires a Gunite straight style clevis kit. 6.5" arm length only.
409-10146	AS1039	Requires a Gunite straight style clevis kit. 5.0" arm length only.
409-10146	AS1041	Requires a Gunite straight style clevis kit. 6.0" arm length only.
409-10149	AS1039	Requires a Gunite straight style clevis kit. 5.0" arm length only.
409-10149	AS1041	Requires a Gunite straight style clevis kit. 6.0" arm length only.
409-10150	AS1040	Requires a Gunite straight style clevis kit.
409-10167	AS1039	Requires a Gunite straight style clevis kit. 5.0" arm length only.
409-10167	AS1041	Requires a Gunite straight style clevis kit. 6.0" arm length only.
409-10168	AS1040	Requires a Gunite straight style clevis kit. 5.5" arm length only.
409-10172	AS1036	Requires a Gunite straight style clevis kit.
409-10174	AS1040	Requires a Gunite straight style clevis kit.
409-10178	AS1039	Requires a Gunite straight style clevis kit. 5.0" arm length only.
409-10178	AS1041	Requires a Gunite straight style clevis kit. 6.0" arm length only.
409-10197	AS1040	Requires a Gunite straight style clevis kit. 5.5" arm length only.
409-10197	AS1042	Requires a Gunite straight style clevis kit. 6.5" arm length only.
409-10215	AS1040	Requires a Gunite straight style clevis kit. 5.5" arm length only.
409-10215	AS1042	Requires a Gunite straight style clevis kit. 6.5" arm length only.
409-10218	AS1044	Requires a Gunite straight style clevis kit.
409-10221	AS1031	Requires a Gunite straight style clevis kit. 5.0" arm length only.
409-10221	AS1033	Requires a Gunite straight style clevis kit. 6.0" arm length only.

**Replacement of other brands of slack adjusters should be done in axle sets.** Industry Part Numbers referencing more than a single interchange is the result of Gunite offering the option of ordering its Automatic Slack Adjusters with or without the clevis kit.

Features and Benefits  
Numerical Listings  
Axle Applications  
Obsolete Products  
Cross References



## CROSS REFERENCES

### INDUSTRY TO GUNITE

Industry P/N	Gunite Aftermarket P/N	Special Information
<b>Haldex Brake Systems (continued)</b>		
409-10222	AS1040	Requires a Gunite straight style clevis kit. 5.5" arm length only.
409-10222	AS1042	Requires a Gunite straight style clevis kit. 6.5" arm length only.
409-10223	AS1032	Requires a Gunite straight style clevis kit.
409-10224	AS1036	Requires a Gunite straight style clevis kit.
409-10225	AS1039	Requires a Gunite straight style clevis kit. 5.0" arm length only.
409-10225	AS1041	Requires a Gunite straight style clevis kit. 6.0" arm length only.
409-10226	AS1031	Requires a Gunite straight style clevis kit. 5.0" arm length only.
409-10226	AS1033	Requires a Gunite straight style clevis kit. 6.0" arm length only.
409-10228	AS1040	Requires a Gunite straight style clevis kit. 5.5" arm length only.
409-10228	AS1042	Requires a Gunite straight style clevis kit. 6.5" arm length only.
409-10229	AS1040	Requires a Gunite straight style clevis kit. 5.5" arm length only.
409-10229	AS1042	Requires a Gunite straight style clevis kit. 6.5" arm length only.
409-10230	AS1031	Requires a Gunite straight style clevis kit. 5.0" arm length only.
409-10230	AS1033	Requires a Gunite straight style clevis kit. 6.0" arm length only.
409-10231	AS1031	Requires a Gunite straight style clevis kit. 5.0" arm length only.
409-10231	AS1033	Requires a Gunite straight style clevis kit. 6.0" arm length only.
409-10232	AS1032	Requires a Gunite straight style clevis kit. 5.5" arm length only.
409-10232	AS1034	Requires a Gunite straight style clevis kit. 6.5" arm length only.
409-10233	AS1032	Requires a Gunite straight style clevis kit. 5.5" arm length only.
409-10233	AS1034	Requires a Gunite straight style clevis kit. 6.5" arm length only.
409-10234	AS1038	Requires a Gunite straight style clevis kit. 5.0" arm length only.
409-10234	AS1041	Requires a Gunite straight style clevis kit. 6.0" arm length only.
409-10235	AS1038	Requires a Gunite straight style clevis kit. 5.0" arm length only.
409-10235	AS1041	Requires a Gunite straight style clevis kit. 6.0" arm length only.
409-10236	AS1040	Requires a Gunite straight style clevis kit. 5.5" arm length only.
409-10236	AS1042	Requires a Gunite straight style clevis kit. 6.5" arm length only.
409-10237	AS1040	Requires a Gunite straight style clevis kit. 5.5" arm length only.
409-10237	AS1042	Requires a Gunite straight style clevis kit. 6.5" arm length only.
409-10238	AS1032	Requires a Gunite straight style clevis kit. 5.5" arm length only.
409-10238	AS1034	Requires a Gunite straight style clevis kit. 6.5" arm length only.
409-10239	AS1031	Requires a Gunite straight style clevis kit. 5.0" arm length only.
409-10239	AS1033	Requires a Gunite straight style clevis kit. 6.0" arm length only.
409-10240	AS1040	Requires a Gunite straight style clevis kit. 5.5" arm length only.
409-10240	AS1042	Requires a Gunite straight style clevis kit. 6.5" arm length only.

Industry P/N	Gunite Aftermarket P/N	Special Information
<b>Haldex Brake Systems (continued)</b>		
409-10241	AS1039	Requires a Gunite straight style clevis kit. 5.0" arm length only.
409-10241	AS1041	Requires a Gunite straight style clevis kit. 6.0" arm length only.
409-10247	AS1031	Requires a Gunite straight style clevis kit. 5.0" arm length only.
409-10247	AS1033	Requires a Gunite straight style clevis kit. 6.0" arm length only.
409-10249	AS1036	Requires a Gunite .625" offset style clevis kit.
409-10250	AS1036	Requires a Gunite .625" offset style clevis kit.
409-10257	AS1032	Requires a Gunite straight style clevis kit.
409-10258	AS1040	Requires a Gunite straight style clevis kit.
409-10263	AS1032	Requires a Gunite .625" offset style clevis kit.
409-10264	AS1032	Requires a Gunite .625" offset style clevis kit.
409-10287	AS1033	Requires a Gunite straight style clevis kit.
409-10288	AS1041	Requires a Gunite straight style clevis kit.
409-10293	AS1032	Requires a Gunite straight style clevis kit. 5.5" arm length only.
409-10293	AS1034	Requires a Gunite straight style clevis kit. 6.5" arm length only.
409-10294	AS1032	Requires a Gunite straight style clevis kit. 5.5" arm length only.
409-10294	AS1034	Requires a Gunite straight style clevis kit. 6.5" arm length only.
409-10312	AS1040	Requires a Gunite straight style clevis kit. 5.5" arm length only.
409-10312	AS1042	Requires a Gunite straight style clevis kit. 6.5" arm length only.
409-10313	AS1032	Requires a Gunite straight style clevis kit. 5.5" arm length only.
409-10313	AS1034	Requires a Gunite straight style clevis kit. 6.5" arm length only.
409-10314	AS1039	Requires a Gunite straight style clevis kit. 5.0" arm length only.
409-10314	AS1041	Requires a Gunite straight style clevis kit. 6.0" arm length only.
409-10315	AS1031	Requires a Gunite straight style clevis kit. 5.0" arm length only.
409-10315	AS1033	Requires a Gunite straight style clevis kit. 6.0" arm length only.
409-10317	AS1031	Requires a Gunite straight style clevis kit. 5.0" arm length only.
409-10317	AS1033	Requires a Gunite straight style clevis kit. 6.0" arm length only.
409-10319	AS1038	Requires a Gunite straight style clevis kit.
409-10325	AS1036	Requires a Gunite .625" offset style clevis kit.
409-10326	AS1036	Requires a Gunite .625" offset style clevis kit.
409-10334	AS1038	Requires a Gunite .625" offset style clevis kit.
409-10335	AS1038	Requires a Gunite .625" offset style clevis kit.
409-10343	AS1039	Requires a Gunite straight style clevis kit. 5.0" arm length only.
409-10343	AS1041	Requires a Gunite straight style clevis kit. 6.0" arm length only.
409-10351	AS1043	Requires a Gunite straight style clevis kit.
409-10352	AS1041	Requires a Gunite straight style clevis kit.
409-10360	AS1039	Requires a Gunite straight style clevis kit. 5.0" arm length only.
409-10360	AS1041	Requires a Gunite straight style clevis kit. 6.0" arm length only.

**Replacement of other brands of slack adjusters should be done in axle sets.** Industry Part Numbers referencing more than a single interchange is the result of Gunite offering the option of ordering its Automatic Slack Adjusters with or without the clevis kit.

# CROSS REFERENCES

## INDUSTRY TO GUNITE

Industry P/N	Gunite Aftermarket P/N	Special Information
<b>Haldex Brake Systems (continued)</b>		
409-10361	AS1038	Requires a Gunite straight style clevis kit.
409-10362	AS1040	Requires a Gunite straight style clevis kit.
409-10364	AS1038	Requires a Gunite straight style clevis kit.
409-10365	AS1033	Requires a Gunite straight style clevis kit.
409-10370	AS1032	Requires a Gunite straight style clevis kit.
409-10384	AS1040	Requires a Gunite straight style clevis kit.
409-10385	AS1038	Requires a Gunite straight style clevis kit.
409-10386	AS1040	Requires a Gunite straight style clevis kit.
409-10390	AS1040	Requires a Gunite straight style clevis kit.
409-10391	AS1036	Requires a Gunite straight style clevis kit.
409-10392	AS1033	Requires a Gunite straight style clevis kit.
409-10393	AS1033	Requires a Gunite straight style clevis kit.
409-10394	AS1032	Requires a Gunite straight style clevis kit.
409-10395	AS1032	Requires a Gunite straight style clevis kit.
409-10396	AS1041	Requires a Gunite straight style clevis kit.
409-10397	AS1041	Requires a Gunite straight style clevis kit.
409-10398	AS1040	Requires a Gunite straight style clevis kit.
409-10399	AS1040	Requires a Gunite straight style clevis kit.
409-10404	AS1041	Requires a Gunite straight style clevis kit.
409-10405	AS1039	Requires a Gunite straight style clevis kit. 5.0" arm length only.
409-10405	AS1041	Requires a Gunite straight style clevis kit. 6.0" arm length only.
409-10406	AS1040	Requires a Gunite straight style clevis kit.
409-10407	AS1040	Requires a Gunite straight style clevis kit.
409-10408	AS1040	Requires a Gunite straight style clevis kit. 5.5" arm length only.
409-10408	AS1042	Requires a Gunite straight style clevis kit. 6.5" arm length only.
409-10410	AS1031	Requires a Gunite straight style clevis kit. 5.0" arm length only.
409-10410	AS1033	Requires a Gunite straight style clevis kit. 6.0" arm length only.
409-10412	AS1032	Requires a Gunite straight style clevis kit. 5.5" arm length only.
409-10412	AS1034	Requires a Gunite straight style clevis kit. 6.5" arm length only.
409-10416	AS1040	Requires a Gunite straight style clevis kit. 5.5" arm length only.
409-10416	AS1042	Requires a Gunite straight style clevis kit. 6.5" arm length only.
409-10417	AS1032	Requires a Gunite straight style clevis kit. 5.5" arm length only.
409-10417	AS1034	Requires a Gunite straight style clevis kit. 6.5" arm length only.
409-10426	AS1039	Requires a Gunite straight style clevis kit. 5.0" arm length only.
409-10426	AS1041	Requires a Gunite straight style clevis kit. 6.0" arm length only.
409-10429	AS1040	Requires a Gunite straight style clevis kit.
409-10430	AS1040	Requires a Gunite straight style clevis kit.
409-10432	AS1043	Requires a Gunite straight style clevis kit.
409-10443	AS1041	Requires a Gunite straight style clevis kit.

Industry P/N	Gunite Aftermarket P/N	Special Information
<b>Haldex Brake Systems (continued)</b>		
409-10444	AS1040	Requires a Gunite straight style clevis kit. 5.5" arm length only.
409-10444	AS1042	Requires a Gunite straight style clevis kit. 6.5" arm length only.
409-10455	AS1033	Requires a Gunite straight style clevis kit.
409-10457	AS1039	Requires a Gunite straight style clevis kit. 5.0" arm length only.
409-10457	AS1041	Requires a Gunite straight style clevis kit. 6.0" arm length only.
409-10458	AS1031	Requires a Gunite straight style clevis kit. 5.0" arm length only.
409-10458	AS1033	Requires a Gunite straight style clevis kit. 6.0" arm length only.
409-10465	AS1038	Requires a Gunite straight style clevis kit.
409-10466	AS1040	Requires a Gunite straight style clevis kit.
409-10471	AS1040	Requires a Gunite straight style clevis kit.
409-10472	AS1041	Requires a Gunite straight style clevis kit.
409-10473	AS1043	Requires a Gunite straight style clevis kit.
409-10474	AS1044	Requires a Gunite straight style clevis kit.
409-10475	AS1032	Requires a Gunite straight style clevis kit.
409-10476	AS1033	Requires a Gunite straight style clevis kit.
409-10495	AS1036	Requires a Gunite straight style clevis kit.
409-10496	AS1038	Requires a Gunite straight style clevis kit.
409-10497	AS1036	Requires a Gunite .625" offset style clevis kit.
409-10498	AS1036	Requires a Gunite .625" offset style clevis kit.
409-10499	AS1032	Requires a Gunite straight style clevis kit.
409-10502	AS1040	Requires a Gunite straight style clevis kit.
409-10504	AS1033	Requires a Gunite straight style clevis kit.
409-10505	AS1033	Requires a Gunite straight style clevis kit.
409-10506	AS1040	Requires a Gunite straight style clevis kit. 5.5" arm length only.
409-10506	AS1042	Requires a Gunite straight style clevis kit. 6.5" arm length only.
409-10509	AS1032	Requires a Gunite straight style clevis kit. 5.5" arm length only.
409-10509	AS1034	Requires a Gunite straight style clevis kit. 6.5" arm length only.
409-10512	AS1040	Requires a Gunite straight style clevis kit.
409-10529	AS1041	Requires a Gunite straight style clevis kit.
409-10530	AS1040	Requires a Gunite straight style clevis kit. 5.5" arm length only.
409-10530	AS1042	Requires a Gunite straight style clevis kit. 6.5" arm length only.
409-10531	AS1039	Requires a Gunite straight style clevis kit. 5.0" arm length only.
409-10531	AS1041	Requires a Gunite straight style clevis kit. 6.0" arm length only.
409-10532	AS1040	Requires a Gunite straight style clevis kit. 5.5" arm length only.
409-10532	AS1042	Requires a Gunite straight style clevis kit. 6.5" arm length only.
409-10533	AS1031	Requires a Gunite straight style clevis kit. 5.0" arm length only.
409-10533	AS1033	Requires a Gunite straight style clevis kit. 6.0" arm length only.
409-10535	AS1038	Requires a Gunite .625" offset style clevis kit.

**Replacement of other brands of slack adjusters should be done in axle sets.** Industry Part Numbers referencing more than a single interchange is the result of Gunite offering the option of ordering its Automatic Slack Adjusters with or without the clevis kit.

Features and Benefits  
Numerical Listings  
Axle Applications  
Obsolete Products  
Cross References

## CROSS REFERENCES

### INDUSTRY TO GUNITE

Industry P/N	Gunite Aftermarket P/N	Special Information
<b>Haldex Brake Systems (continued)</b>		
409-10536	AS1038	Requires a Gunite .625" offset style clevis kit.
409-10548	AS1032	Requires a Gunite straight style clevis kit. 5.5" arm length only.
409-10548	AS1034	Requires a Gunite straight style clevis kit. 6.5" arm length only.
409-10551	AS1040	Requires a Gunite straight style clevis kit. 5.5" arm length only.
409-10551	AS1042	Requires a Gunite straight style clevis kit. 6.5" arm length only.
409-10552	AS1039	Requires a Gunite straight style clevis kit. 5.0" arm length only.
409-10552	AS1041	Requires a Gunite straight style clevis kit. 6.0" arm length only.
409-10553	AS1040	Requires a Gunite straight style clevis kit. 5.5" arm length only.
409-10553	AS1042	Requires a Gunite straight style clevis kit. 6.5" arm length only.
409-10561	AS1039	Requires a Gunite straight style clevis kit. 5.0" arm length only.
409-10561	AS1041	Requires a Gunite straight style clevis kit. 6.0" arm length only.
409-10564	AS1031	Requires a Gunite straight style clevis kit. 5.0" arm length only.
409-10564	AS1033	Requires a Gunite straight style clevis kit. 6.0" arm length only.
409-10565	AS1032	Requires a Gunite straight style clevis kit. 5.5" arm length only.
409-10565	AS1034	Requires a Gunite straight style clevis kit. 6.5" arm length only.
409-10566	AS1039	Requires a Gunite straight style clevis kit. 5.0" arm length only.
409-10566	AS1041	Requires a Gunite straight style clevis kit. 6.0" arm length only.
409-10579	AS1041	Requires a Gunite straight style clevis kit.
409-10580	AS1040	Requires a Gunite straight style clevis kit. 5.5" arm length only.
409-10580	AS1042	Requires a Gunite straight style clevis kit. 6.5" arm length only.
409-10581	AS1033	Requires a Gunite straight style clevis kit.
409-10605	AS1040	Requires a Gunite straight style clevis kit.
409-10615	AS1039	Requires a Gunite straight style clevis kit. 5.0" arm length only.
409-10615	AS1041	Requires a Gunite straight style clevis kit. 6.0" arm length only.
409-10626	AS1031	Requires a Gunite straight style clevis kit. 5.0" arm length only.
409-10626	AS1033	Requires a Gunite straight style clevis kit. 6.0" arm length only.
409-10627	AS1032	Requires a Gunite straight style clevis kit. 5.5" arm length only.
409-10627	AS1034	Requires a Gunite straight style clevis kit. 6.5" arm length only.
409-10628	AS1040	Requires a Gunite straight style clevis kit.
409-10635	AS1032	Requires a Gunite straight style clevis kit.
409-10637	AS1040	Requires a Gunite straight style clevis kit.
409-10648	AS1040	Requires a Gunite straight style clevis kit.
409-10649	AS1032	Requires a Gunite straight style clevis kit. 5.5" arm length only.
409-10649	AS1034	Requires a Gunite straight style clevis kit. 6.5" arm length only.
409-10650	AS1040	Requires a Gunite straight style clevis kit.

Industry P/N	Gunite Aftermarket P/N	Special Information
<b>Haldex Brake Systems (continued)</b>		
409-10653	AS1040	Requires a Gunite straight style clevis kit.
409-10658	AS1036	Requires a Gunite straight style clevis kit.
409-10659	AS1038	Requires a Gunite straight style clevis kit.
409-10660	AS1036	Requires a Gunite .625" offset style clevis kit.
409-10661	AS1036	Requires a Gunite .625" offset style clevis kit.
409-10662	AS1032	Requires a Gunite straight style clevis kit.
409-10663	AS1040	Requires a Gunite straight style clevis kit.
409-10664	AS1038	Requires a Gunite .625" offset style clevis kit.
409-10665	AS1038	Requires a Gunite .625" offset style clevis kit.
409-10670	AS1040	Requires a Gunite straight style clevis kit.
409-10673	AS1041	Requires a Gunite straight style clevis kit.
409-10674	AS1044	Requires a Gunite straight style clevis kit.
409-10675	AS1033	Requires a Gunite straight style clevis kit.
409-10678	AS1041	Requires a Gunite straight style clevis kit.
409-10679	AS1040	Requires a Gunite straight style clevis kit. 5.5" arm length only.
409-10679	AS1042	Requires a Gunite straight style clevis kit. 6.5" arm length only.
409-10680	AS1033	Requires a Gunite straight style clevis kit.
409-10682	AS1040	Requires a Gunite straight style clevis kit. 5.5" arm length only.
409-10682	AS1042	Requires a Gunite straight style clevis kit. 6.5" arm length only.
409-10683	AS1040	Requires a Gunite straight style clevis kit.
409-10684	AS1043	Requires a Gunite straight style clevis kit.
409-10685	AS1032	Requires a Gunite straight style clevis kit.
409-10731	AS1031	Requires a Gunite straight style clevis kit. 5.0" arm length only.
409-10731	AS1033	Requires a Gunite straight style clevis kit. 6.0" arm length only.
409-10732	AS1039	Requires a Gunite straight style clevis kit. 5.0" arm length only.
409-10732	AS1041	Requires a Gunite straight style clevis kit. 6.0" arm length only.
409-10733	AS1032	Requires a Gunite straight style clevis kit. 5.5" arm length only.
409-10733	AS1034	Requires a Gunite straight style clevis kit. 6.5" arm length only.
409-10741	AS1031	Requires a Gunite straight style clevis kit. 5.0" arm length only.
409-10741	AS1033	Requires a Gunite straight style clevis kit. 6.0" arm length only.
409-10742	AS1039	Requires a Gunite straight style clevis kit. 5.0" arm length only.
409-10742	AS1041	Requires a Gunite straight style clevis kit. 6.0" arm length only.
409-10759	AS1040	Requires a Gunite straight style clevis kit.
409-10760	AS1032	Requires a Gunite straight style clevis kit.
409-10761	AS1036	Requires a Gunite straight style clevis kit.
409-10762	AS1038	Requires a Gunite straight style clevis kit.
409-10774	AS1032	Requires a Gunite .625" offset style clevis kit.
409-10775	AS1032	Requires a Gunite .625" offset style clevis kit.
409-10787	AS1032	Requires a Gunite straight style clevis kit.

**Replacement of other brands of slack adjusters should be done in axle sets.** Industry Part Numbers referencing more than a single interchange is the result of Gunite offering the option of ordering its Automatic Slack Adjusters with or without the clevis kit.



# CROSS REFERENCES

## INDUSTRY TO GUNITE

Industry P/N	Gunite Aftermarket P/N	Special Information
<b>Haldex Brake Systems (continued)</b>		
409-10797	AS1032	Requires a Gunite straight style clevis kit. 5.5" arm length only.
409-10797	AS1034	Requires a Gunite straight style clevis kit. 6.5" arm length only.
409-10813	AS1032	Requires a Gunite straight style clevis kit. 5.5" arm length only.
409-10813	AS1034	Requires a Gunite straight style clevis kit. 6.5" arm length only.
409-10814	AS1040	Requires a Gunite straight style clevis kit.
409-10815	AS1031	Requires a Gunite straight style clevis kit. 5.0" arm length only.
409-10815	AS1033	Requires a Gunite straight style clevis kit. 6.0" arm length only.
409-10816	AS1039	Requires a Gunite straight style clevis kit. 5.0" arm length only.
409-10816	AS1041	Requires a Gunite straight style clevis kit. 6.0" arm length only.
409-10843	AS1031	Requires a Gunite straight style clevis kit. 5.0" arm length only.
409-10843	AS1033	Requires a Gunite straight style clevis kit. 6.0" arm length only.
409-10858	AS1039	Requires a Gunite straight style clevis kit. 5.0" arm length only.
409-10858	AS1041	Requires a Gunite straight style clevis kit. 6.0" arm length only.
409-10859	AS1031	Requires a Gunite straight style clevis kit. 5.0" arm length only.
409-10859	AS1033	Requires a Gunite straight style clevis kit. 6.0" arm length only.
409-10860	AS1032	Requires a Gunite straight style clevis kit. 5.5" arm length only.
409-10860	AS1034	Requires a Gunite straight style clevis kit. 6.5" arm length only.
409-10861	AS1040	Requires a Gunite straight style clevis kit.
409-10862	AS1031	Requires a Gunite straight style clevis kit. 5.0" arm length only.
409-10862	AS1033	Requires a Gunite straight style clevis kit. 6.0" arm length only.
409-10868	AS1039	Requires a Gunite straight style clevis kit. 5.0" arm length only.
409-10868	AS1041	Requires a Gunite straight style clevis kit. 6.0" arm length only.
409-10869	AS1032	Requires a Gunite straight style clevis kit. 5.5" arm length only.
409-10869	AS1034	Requires a Gunite straight style clevis kit. 6.5" arm length only.
409-10870	AS1040	Requires a Gunite straight style clevis kit.
409-10871	AS1032	Requires a Gunite straight style clevis kit. 5.5" arm length only.
409-10871	AS1034	Requires a Gunite straight style clevis kit. 6.5" arm length only.
409-10872	AS1040	Requires a Gunite straight style clevis kit.
409-10890	AS1040	Requires a Gunite straight style clevis kit.
409-10893	AS1040	Requires a Gunite straight style clevis kit.
409-10894	AS1040	Requires a Gunite straight style clevis kit.
409-10895	AS1040	Requires a Gunite straight style clevis kit.
409-10896	AS1039	Requires a Gunite straight style clevis kit. 5.0" arm length only.
409-10896	AS1041	Requires a Gunite straight style clevis kit. 6.0" arm length only.
409-10909	AS1032	Requires a Gunite straight style clevis kit. 5.5" arm length only.

Industry P/N	Gunite Aftermarket P/N	Special Information
<b>Haldex Brake Systems (continued)</b>		
409-10909	AS1034	Requires a Gunite straight style clevis kit. 6.5" arm length only.
409-10910	AS1031	Requires a Gunite straight style clevis kit. 5.0" arm length only.
409-10910	AS1033	Requires a Gunite straight style clevis kit. 6.0" arm length only.
409-10946	AS1039	Requires a Gunite straight style clevis kit. 5.0" arm length only.
409-10946	AS1041	Requires a Gunite straight style clevis kit. 6.0" arm length only.
409-10947	AS1039	Requires a Gunite straight style clevis kit. 5.0" arm length only.
409-10947	AS1041	Requires a Gunite straight style clevis kit. 6.0" arm length only.
409-10948	AS1031	Requires a Gunite straight style clevis kit. 5.0" arm length only.
409-10948	AS1033	Requires a Gunite straight style clevis kit. 6.0" arm length only.
409-10949	AS1040	Requires a Gunite straight style clevis kit.
409-10979	AS1040	Requires a Gunite straight style clevis kit.
409-10983	AS1039	Requires a Gunite straight style clevis kit. 5.0" arm length only.
409-10983	AS1041	Requires a Gunite straight style clevis kit. 6.0" arm length only.
409-10984	AS1039	Requires a Gunite straight style clevis kit. 5.0" arm length only.
409-10984	AS1041	Requires a Gunite straight style clevis kit. 6.0" arm length only.
409-20000	AS1032	Requires a Gunite straight style clevis kit.
409-20002	AS1040	Requires a Gunite straight style clevis kit.
409-20004	AS1033	Requires a Gunite straight style clevis kit.
409-20006	AS1041	Requires a Gunite straight style clevis kit.
409-20024	AS1043	Requires a Gunite straight style clevis kit.
409-20025	AS1044	Requires a Gunite straight style clevis kit.
409-10224	AS1036	Requires a Gunite straight style clevis kit.
429-10228	AS1040	Requires a Gunite straight style clevis kit.
429-10238	AS1032	Requires a Gunite straight style clevis kit. 5.5" arm length only.
429-10238	AS1034	Requires a Gunite straight style clevis kit. 6.5" arm length only.
429-10257	AS1032	Requires a Gunite straight style clevis kit.
429-10370	AS1032	Requires a Gunite straight style clevis kit.
CS52315	AS1031	Crewson Industries ASA. Requires the use of either AS3000 or AS3016 clevis kits. 5.0" arm length only.
CS52315	AS1131	Crewson Industries ASA. 5.0" arm length only.
CS52315	AS1033	Crewson Industries ASA. Requires the use of either AS3000 or AS3016 clevis kits. 6.0" arm length only.
CS52315	AS1133	Crewson Industries ASA. 6.0" arm length only.
CS52316	AS1032	Crewson Industries ASA. Requires the use of either AS3000 or AS3016 clevis kits. 5.5" arm length only.
CS52316	AS1132	Crewson Industries ASA. 5.5" arm length only.
CS52316	AS1034	Crewson Industries ASA. Requires the use of either AS3000 or AS3016 clevis kits. 6.5" arm length only.
CS52316	AS1134	Crewson Industries ASA. 6.5" arm length only.
CS52320	AS1040	Crewson Industries ASA. Requires the use of either AS3000 or AS3016 clevis kits. 5.5" arm length only.
CS52320	AS1140	Crewson Industries ASA. 5.5" arm length only.

**Replacement of other brands of slack adjusters should be done in axle sets.** Industry Part Numbers referencing more than a single interchange is the result of Gunite offering the option of ordering its Automatic Slack Adjusters with or without the clevis kit.

Features and Benefits  
Numerical Listings  
Axle Applications  
Obsolete Products  
Cross References



## CROSS REFERENCES

### INDUSTRY TO GUNITE

Industry P/N	Gunite Aftermarket P/N	Special Information
<b>Haldex Systems (continued)</b>		
CS52320	AS1042	Crewson Industries ASA. Requires the use of either AS3000 or AS3016 clevis kits. 6.5" arm length only.
CS52320	AS1142	Crewson Industries ASA. 6.5" arm length only.
CS52321	AS1039	Crewson Industries ASA. Requires the use of either AS3000 or AS3016 clevis kits. 5.0" arm length only.
CS52321	AS1139	Crewson Industries ASA. 5.0" arm length only.
CS52321	AS1041	Crewson Industries ASA. Requires the use of either AS3000 or AS3016 clevis kits. 6.0" arm length only.
CS52321	AS1141	Crewson Industries ASA. 6.0" arm length only.
CS52330	AS1036	Crewson Industries ASA. Requires the use of either AS3000 or AS3016 clevis kits. 5.5" arm length only.
CS52330	AS1136	Crewson Industries ASA. 5.5" arm length only.
CS52331	AS1036	Crewson Industries ASA. Requires the use of AS3003 clevis kit.
CS52332	AS1035	Crewson Industries ASA. Requires the use of either AS3000 or AS3016 clevis kits. 5.0" arm length only.
CS52332	AS1135	Crewson Industries ASA. 5.0" arm length only.
CS52335	AS1038	Crewson Industries ASA. Requires the use of either AS3000 or AS3016 clevis kits. 5.5" arm length only.
CS52335	AS1138	Crewson Industries ASA. 5.5" arm length only.
CS52337	AS1037	Crewson Industries ASA. Requires the use of either AS3000 or AS3016 clevis kits. 5.0" arm length only.
CS52337	AS1137	Crewson Industries ASA. 5.0" arm length only.
<b>Meritor</b>		
A-3275-X-596	AS1039	Requires a Gunite clevis kit. 5.0" arm length only.
A-3275-X-596	AS1139	5.0" arm length only.
A-3275-X-596	AS1041	Requires a Gunite clevis kit. 6.0" arm length only.
A-3275-X-596	AS1141	6.0" arm length only.
A1-3275A1119	AS1042	Requires a Gunite clevis kit.
A1-3275A1119	AS1142	
A1-3275A599S	AS1032	Requires a Gunite clevis kit.
A1-3275A599S	AS1132	
A1-3275B600S	AS1033	Requires a Gunite clevis kit.
A1-3275B600S	AS1133	
A1-3275C601S	AS1034	Requires a Gunite clevis kit.
A1-3275C601S	AS1134	
A1-3275K1051S	AS1031	Requires a Gunite clevis kit.
A1-3275K1051S	AS1131	
A1-3275L792S	AS1033	Requires a Gunite clevis kit.
A1-3275L792S	AS1133	
A1-3275N716S	AS1033	Requires a Gunite clevis kit.
A1-3275N716S	AS1133	
A1-3275N768S	AS1032	Requires a Gunite clevis kit.
A1-3275N768S	AS1132	
A1-3275P718S	AS1034	Requires a Gunite clevis kit.
A1-3275P718S	AS1134	
A1-3275Q1083S	AS1040	Requires a Gunite clevis kit.
A1-3275Q1083S	AS1140	
A1-3275R1084S	AS1040	Requires a Gunite clevis kit.

Industry P/N	Gunite Aftermarket P/N	Special Information
<b>Meritor (continued)</b>		
A1-3275R1084S	AS1140	
A1-3275S1085	AS1039	Requires a Gunite clevis kit.
A1-3275S1085	AS1139	
A1-3275T1086	AS1039	Requires a Gunite clevis kit.
A1-3275T1086	AS1139	
A1-3275T592S	AS1031	Requires a Gunite clevis kit.
A1-3275T592S	AS1131	
A1-3275U593S	AS1032	Requires a Gunite clevis kit.
A1-3275U593S	AS1132	
A1-3275V1139S	AS1032	Requires a Gunite clevis kit.
A1-3275V1139S	AS1132	
A1-3275V594S	AS1033	Requires a Gunite clevis kit.
A1-3275V594S	AS1133	
A1-3275W1089S	AS1040	Requires a Gunite clevis kit.
A1-3275W1089S	AS1140	
A1-3275W595S	AS1034	Requires a Gunite clevis kit.
A1-3275W595S	AS1134	
A1-3275X1090S	AS1040	Requires a Gunite clevis kit.
A1-3275X1090S	AS1140	
A1-3275Y1091S	AS1033	Requires a Gunite clevis kit.
A1-3275Y1091S	AS1133	
A1-3275Z1092S	AS1033	Requires a Gunite clevis kit.
A1-3275Z1092S	AS1133	
A1-3275Z118S	AS1042	Requires a Gunite clevis kit.
A1-3275Z118S	AS1142	
A1-3275Z598S	AS1031	Requires a Gunite clevis kit.
A1-3275Z598S	AS1131	
A2-3275A1119S	AS1042	Requires a Gunite clevis kit.
A2-3275A1119S	AS1142	
A2-3275A599S	AS1040	Requires a Gunite clevis kit.
A2-3275A599S	AS1140	
A2-3275B600S	AS1041	Requires a Gunite clevis kit.
A2-3275B600S	AS1141	
A2-3275C601S	AS1042	Requires a Gunite clevis kit.
A2-3275C601S	AS1142	
A2-3275K1051S	AS1039	Requires a Gunite clevis kit.
A2-3275K1051S	AS1139	
A2-3275L792S	AS1041	Requires a Gunite clevis kit.
A2-3275L792S	AS1141	
A2-3275N1079	AS1038	Requires a Gunite clevis kit.
A2-3275N1079	AS1138	
A2-3275N716S	AS1041	Requires a Gunite clevis kit.
A2-3275N716S	AS1141	
A2-3275N768S	AS1040	Requires a Gunite clevis kit.

**Replacement of other brands of slack adjusters should be done in axle sets.** Industry Part Numbers referencing more than a single interchange is the result of Gunite offering the option of ordering its Automatic Slack Adjusters with or without the clevis kit.

# CROSS REFERENCES

## INDUSTRY TO GUNITE

Industry P/N	Gunite Aftermarket P/N	Special Information
Meritor (continued)		
A2-3275N768S	AS1140	
A2-3275P718S	AS1042	Requires a Gunite clevis kit.
A2-3275P718S	AS1142	
A2-3275Q1083	AS1032	Requires a Gunite clevis kit.
A2-3275Q1083	AS1132	
A2-3275R1084	AS1032	Requires a Gunite clevis kit.
A2-3275R1084	AS1132	
A2-3275T592S	AS1039	Requires a Gunite clevis kit.
A2-3275T592S	AS1139	
A2-3275U1087S	AS1039	Requires a Gunite clevis kit.
A2-3275U1087S	AS1139	
A2-3275U1139S	AS1040	Requires a Gunite clevis kit.
A2-3275U1139S	AS1140	
A2-3275U593S	AS1040	Requires a Gunite clevis kit.
A2-3275U593S	AS1140	
A2-3275V1088S	AS1039	Requires a Gunite clevis kit.
A2-3275V1088S	AS1139	
A2-3275V594S	AS1041	Requires a Gunite clevis kit.
A2-3275V594S	AS1141	
A2-3275W1089S	AS1040	Requires a Gunite clevis kit.
A2-3275W1089S	AS1140	
A2-3275W595S	AS1042	Requires a Gunite clevis kit.
A2-3275W595S	AS1142	
A2-3275W59S	AS1042	Requires a Gunite clevis kit.
A2-3275W59S	AS1142	
A2-3275X1090S	AS1040	Requires a Gunite clevis kit.
A2-3275X1090S	AS1140	
A2-3275Y1091S	AS1041	Requires a Gunite clevis kit.
A2-3275Y1091S	AS1141	
A2-3275Z1092S	AS1041	Requires a Gunite clevis kit.
A2-3275Z1092S	AS1141	
A2-3275Z598S	AS1039	Requires a Gunite clevis kit.
A2-3275Z598S	AS1139	
A2-3276A599S	AS1040	Requires a Gunite clevis kit.
A2-3276A599S	AS1140	
A3-3275B1042S	AS1039	Requires a Gunite clevis kit.
A3-3275B1042S	AS1139	
A3-3275N716S	AS1044	Requires a Gunite clevis kit.
A3-3275N716S	AS1144	
A3-3275P718S	AS1034	Requires a Gunite clevis kit.
A3-3275P718S	AS1134	
A3-3275W1089S	AS1032	Requires a Gunite clevis kit.
A3-3275W1089S	AS1132	
A3-3275X1090S	AS1032	Requires a Gunite clevis kit.

Industry P/N	Gunite Aftermarket P/N	Special Information
Meritor (continued)		
A3-3275X1090S	AS1132	
A4-3275B1042S	AS1031	Requires a Gunite clevis kit.
A4-3275B1042S	AS1131	
A4-3275N716S	AS1033	Requires a Gunite clevis kit.
A4-3275N716S	AS1133	
A4-3275N768S	AS1036	Requires a Gunite clevis kit.
A4-3275N768S	AS1136	
A4-3275P718S	AS1042	Requires a Gunite clevis kit.
A4-3275P718S	AS1142	
A4-3275W1089S	AS1032	Requires a Gunite clevis kit.
A4-3275W1089S	AS1132	
A4-3275X1090S	AS1032	Requires a Gunite clevis kit.
A4-3275X1090S	AS1132	
A4-3780A27	AS1036	Requires a Gunite clevis kit.
A4-3780A27	AS1136	
A4-3780B28	AS1032	Requires a Gunite clevis kit.
A4-3780B28	AS1132	
A4-3780C29	AS1032	Requires a Gunite clevis kit.
A4-3780C29	AS1132	
A4-3780H8	AS1036	Requires a Gunite clevis kit.
A4-3780H8	AS1136	
A4-3780K11	AS1032	Requires a Gunite clevis kit.
A4-3780K11	AS1132	
A4-3780M13	AS1032	Requires a Gunite clevis kit.
A4-3780M13	AS1132	
A4-3780Z26	AS1036	Requires a Gunite clevis kit.
A4-3780Z26	AS1136	
A5-3275-A-599S	AS1043	Requires a Gunite clevis kit.
A5-3275-A-599S	AS1143	
A5-3275-B-600S	AS1044	Requires a Gunite clevis kit.
A5-3275-B-600S	AS1144	
A5-3275-C-601S	AS1045	Requires a Gunite clevis kit.
A5-3275-C-601S	AS1145	
A5-3275-N-716S	AS1041	Requires a Gunite clevis kit.
A5-3275-N-716S	AS1141	
A5-3275-N-768S	AS1040	Requires a Gunite clevis kit.
A5-3275-N-768S	AS1140	
A5-3275-U-593S	AS1043	Requires a Gunite clevis kit.
A5-3275-U-593S	AS1143	
A5-3275-V-594S	AS1044	Requires a Gunite clevis kit.
A5-3275-V-594S	AS1144	
A5-3275-W-595S	AS1045	Requires a Gunite clevis kit.
A5-3275-W-595S	AS1145	
A6-3275-A-599S	AS1032	Requires a Gunite clevis kit.

**Replacement of other brands of slack adjusters should be done in axle sets.** Industry Part Numbers referencing more than a single interchange is the result of Gunite offering the option of ordering its Automatic Slack Adjusters with or without the clevis kit.

Features and Benefits

Numerical Listings

Axle Applications

Obsolete Products

Cross References

## CROSS REFERENCES

### INDUSTRY TO GUNITE

Industry P/N	Gunite Aftermarket P/N	Special Information
<b>Meritor (continued)</b>		
A6-3275-A-599S	AS1132	
A6-3275-N-768S	AS1040	Requires a Gunite clevis kit.
A6-3275-N-768S	AS1140	
A6-3275-T-592S	AS1035	Requires a Gunite clevis kit.
A6-3275-T-592S	AS1135	
A6-3275-Z-598S	AS1035	Requires a Gunite clevis kit.
A6-3275-Z-598S	AS1135	
A7-3275-A-599S	AS1036	Requires a Gunite clevis kit.
A7-3275-A-599S	AS1136	
A7-3275-N-768S	AS1032	Requires a Gunite clevis kit.
A7-3275-N-768S	AS1132	
A7-3275-T-592S	AS1035	Requires a Gunite clevis kit.
A7-3275-T-592S	AS1135	
A7-3275-U-593S	AS1032	Requires a Gunite clevis kit.
A7-3275-U-593S	AS1132	
A7-3275-Z-592S	AS1035	Requires a Gunite clevis kit.
A7-3275-Z-592S	AS1135	
A7-3275-Z-598S	AS1036	Requires a Gunite clevis kit.
A7-3275-Z-598S	AS1136	
A8-3275-A-599S	AS1036	Requires a Gunite clevis kit.
A8-3275-A-599S	AS1136	
A8-3275-N-716S	AS1033	Requires a Gunite clevis kit.
A8-3275-N-716S	AS1133	
A8-3275-N-768S	AS1040	Requires a Gunite clevis kit.
A8-3275-N-768S	AS1140	
A8-3275-T-592S	AS1031	Requires a Gunite clevis kit.
A8-3275-T-592S	AS1131	
A8-3275-U-593S	AS1036	Requires a Gunite clevis kit.
A8-3275-U-593S	AS1136	
A8-3275-Z-598S	AS1031	Requires a Gunite clevis kit.
A8-3275-Z-598S	AS1131	
A9-3275-A-599S	AS1037	Requires a Gunite clevis kit.
A9-3275-A-599S	AS1137	
A9-3275-N-716S	AS1033	Requires a Gunite clevis kit.
A9-3275-N-716S	AS1133	
A9-3275-T-592S	AS1031	Requires a Gunite clevis kit.
A9-3275-T-592S	AS1131	
A9-3275-U-593S	AS1036	Requires a Gunite clevis kit.
A9-3275-U-593S	AS1136	
A9-3275-Z-598S	AS1031	Requires a Gunite clevis kit.
A9-3275-Z-598S	AS1131	
A10-3275A599S	AS1032	Requires a Gunite clevis kit.
A10-3275A599S	AS1132	
A10-3275E1045S	AS1036	Requires a Gunite clevis kit.

Industry P/N	Gunite Aftermarket P/N	Special Information
<b>Meritor (continued)</b>		
A10-3275E1045S	AS1136	
A10-3275F1046S	AS1036	Requires a Gunite clevis kit.
A10-3275F1046S	AS1136	
A10-3275N716S	AS1041	Requires a Gunite clevis kit.
A10-3275N716S	AS1141	
A10-3275T592S	AS1039	Requires a Gunite clevis kit.
A10-3275T592S	AS1139	
A10-3275U593S	AS1032	Requires a Gunite clevis kit.
A10-3275U593S	AS1132	
A10-3275Z598S	AS1039	Requires a Gunite clevis kit.
A10-3275Z598S	AS1139	
A11-3275A599S	AS1036	Requires a Gunite clevis kit.
A11-3275A599S	AS1136	
A11-3275C601S	AS1034	Requires a Gunite clevis kit.
A11-3275C601S	AS1134	
A11-3275N716S	AS1041	Requires a Gunite clevis kit.
A11-3275N716S	AS1141	
A11-3275N768S	AS1036	Requires a Gunite clevis kit.
A11-3275N768S	AS1136	
A11-3275U593S	AS1032	Requires a Gunite clevis kit.
A11-3275U593S	AS1132	
A11-3275W595S	AS1034	Requires a Gunite clevis kit.
A11-3275W595S	AS1134	
A12-3275A599S	AS1036	Requires a Gunite clevis kit.
A12-3275A599S	AS1136	
A12-3275C601S	AS1042	Requires a Gunite clevis kit.
A12-3275C601S	AS1142	
A12-3275N716S	AS1044	Requires a Gunite clevis kit.
A12-3275N716S	AS1144	
A12-3275N768S	AS1036	Requires a Gunite clevis kit.
A12-3275N768S	AS1136	
A12-3275T592S	AS1039	Requires a Gunite clevis kit.
A12-3275T592S	AS1139	
A12-3275U593S	AS1036	Requires a Gunite clevis kit.
A12-3275U593S	AS1136	
A12-3275W595S	AS1042	Requires a Gunite clevis kit.
A12-3275W595S	AS1142	
A12-3275Z598S	AS1039	Requires a Gunite clevis kit.
A12-3275Z598S	AS1139	
A13-3275A599S	AS1036	Requires a Gunite clevis kit.
A13-3275A599S	AS1136	
A13-3275C601S	AS1045	Requires a Gunite clevis kit.
A13-3275C601S	AS1145	
A13-3275N716S	AS1033	Requires a Gunite clevis kit.

**Replacement of other brands of slack adjusters should be done in axle sets.** Industry Part Numbers referencing more than a single interchange is the result of Gunite offering the option of ordering its Automatic Slack Adjusters with or without the clevis kit.

## CROSS REFERENCES

### INDUSTRY TO GUNITE

Industry P/N	Gunite Aftermarket P/N	Special Information
Meritor (continued)		
A13-3275N716S	AS1133	
A13-3275N768S	AS1040	Requires a Gunite clevis kit.
A13-3275N768S	AS1140	
A13-3275U593S	AS1036	Requires a Gunite clevis kit.
A13-3275U593S	AS1136	
A13-3275W595S	AS1045	Requires a Gunite clevis kit.
A13-3275W595S	AS1145	
A14-3275A599S	AS1036	Requires a Gunite clevis kit.
A14-3275A599S	AS1136	
A14-3275B600S	AS1033	Requires a Gunite clevis kit.
A14-3275B600S	AS1133	
A14-3275C601S	AS1034	Requires a Gunite clevis kit.
A14-3275C601S	AS1134	
A14-3275N716S	AS1033	Requires a Gunite clevis kit.
A14-3275N716S	AS1133	
A14-3275U593S	AS1036	Requires a Gunite clevis kit.
A14-3275U593S	AS1136	
A14-3275V594S	AS1033	Requires a Gunite clevis kit.
A14-3275W595S	AS1034	Requires a Gunite clevis kit.
A14-3275W595S	AS1134	
A15-3275A599S	AS1032	Requires a Gunite clevis kit.
A15-3275A599S	AS1132	
A15-3275B600S	AS1033	Requires a Gunite clevis kit.
A15-3275B600S	AS1133	
A15-3275C601S	AS1042	Requires a Gunite clevis kit.
A15-3275C601S	AS1142	
A15-3275N716S	AS1041	Requires a Gunite clevis kit.
A15-3275N716S	AS1141	
A15-3275U593S	AS1036	Requires a Gunite clevis kit.
A15-3275U593S	AS1136	
A15-3275V594S	AS1033	Requires a Gunite clevis kit.
A15-3275V594S	AS1133	
A15-3275W595S	AS1042	Requires a Gunite clevis kit.
A15-3275W595S	AS1142	
A16-3275A599S	AS1040	Requires a Gunite clevis kit.
A16-3275A599S	AS1140	
A16-3275B600S	AS1041	Requires a Gunite clevis kit.
A16-3275B600S	AS1141	
A16-3275N716S	AS1041	Requires a Gunite clevis kit.
A16-3275N716S	AS1141	
A16-3275N768S	AS1038	Requires a Gunite clevis kit.
A16-3275N768S	AS1138	
A16-3275U593S	AS1032	Requires a Gunite clevis kit.
A16-3275U593S	AS1132	

Industry P/N	Gunite Aftermarket P/N	Special Information
Meritor (continued)		
A16-3275V594S	AS1041	Requires a Gunite clevis kit.
A16-3275V594S	AS1141	
A16-3276A599S	AS1040	Requires a Gunite clevis kit.
A16-3276A599S	AS1140	
A17-3275A599S	AS1040	Requires a Gunite clevis kit.
A17-3275A599S	AS1140	
A17-3275B600S	AS1041	Requires a Gunite clevis kit.
A17-3275B600S	AS1141	
A17-3275N716S	AS1044	Requires a Gunite clevis kit.
A17-3275N716S	AS1144	
A17-3275U593S	AS1040	Requires a Gunite clevis kit.
A17-3275U593S	AS1140	
A17-3275V594S	AS1041	Requires a Gunite clevis kit.
A17-3275V594S	AS1141	
A18-3275B600S	AS1044	Requires a Gunite clevis kit.
A18-3275B600S	AS1144	
A18-3275N716S	AS1044	Requires a Gunite clevis kit.
A18-3275N716S	AS1144	
A18-3275N768S	AS1040	Requires a Gunite clevis kit.
A18-3275N768S	AS1140	
A18-3275U593S	AS1040	Requires a Gunite clevis kit.
A18-3275U593S	AS1140	
A18-3275V594S	AS1044	Requires a Gunite clevis kit.
A18-3275V594S	AS1144	
A19-3275N716S	AS1041	Requires a Gunite clevis kit.
A19-3275N716S	AS1141	
A19-3275N768S	AS1040	Requires a Gunite clevis kit.
A19-3275N768S	AS1140	
A20-3275N716S	AS1041	Requires a Gunite clevis kit.
A20-3275N716S	AS1141	
A20-3275N768S	AS1043	Requires a Gunite clevis kit.
A20-3275N768S	AS1143	
A20-3275T592S	AS1031	Requires a Gunite clevis kit.
A20-3275T592S	AS1131	
A20-3275Z598S	AS1031	Requires a Gunite clevis kit.
A20-3275Z598S	AS1131	
A21-3275A599S	AS1040	Requires a Gunite clevis kit.
A21-3275A599S	AS1140	
A21-3275B600S	AS1044	Requires a Gunite clevis kit.
A21-3275B600S	AS1144	
A21-3275N768S	AS1040	Requires a Gunite clevis kit.
A21-3275N768S	AS1140	
A21-3275U593S	AS1040	Requires a Gunite clevis kit.
A21-3275U593S	AS1140	

**Replacement of other brands of slack adjusters should be done in axle sets.** Industry Part Numbers referencing more than a single interchange is the result of Gunite offering the option of ordering its Automatic Slack Adjusters with or without the clevis kit.

Features and Benefits

Numerical Listings

Axle Applications

Obsolete Products

Cross References



## CROSS REFERENCES

### INDUSTRY TO GUNITE

Industry P/N	Gunite Aftermarket P/N	Special Information
<b>Meritor (continued)</b>		
A21-3275V594S	AS1044	Requires a Gunite clevis kit.
A21-3275V594S	AS1144	
A22-3275B600S	AS1041	Requires a Gunite clevis kit.
A22-3275B600S	AS1141	
A22-3275N768S	AS1032	Requires a Gunite clevis kit.
A22-3275N768S	AS1132	
A22-3275V594S	AS1041	Requires a Gunite clevis kit.
A22-3275V594S	AS1141	
A23-3275N768S	AS1040	Requires a Gunite clevis kit.
A23-3275N768S	AS1140	
A24-3275N768S	AS1040	Requires a Gunite clevis kit.
A24-3275N768S	AS1140	
A25-3275A599S	AS1040	Requires a Gunite clevis kit.
A25-3275A599S	AS1140	
A25-3275M1079	AS1041	Requires a Gunite clevis kit.
A25-3275M1079	AS1141	
A25-3275N768S	AS1038	Requires a Gunite clevis kit.
A25-3275N768S	AS1138	
A25-3275T592S	AS1031	Requires a Gunite clevis kit.
A25-3275T592S	AS1131	
A25-3275U593S	AS1040	Requires a Gunite clevis kit.
A25-3275U593S	AS1140	
A25-3275Z598S	AS1031	Requires a Gunite clevis kit.
A25-3275Z598S	AS1131	
A26-3275N768S	AS1032	Requires a Gunite clevis kit.
A26-3275N768S	AS1132	
A27-3275N768S	AS1036	Requires a Gunite clevis kit.
A27-3275N768S	AS1136	
A3275X596	AS1039	Requires a Gunite clevis kit.
A3275X596	AS1139	
A3275X596	AS1041	Requires a Gunite clevis kit.
A3275X596	AS1141	
A33-3275N768S	AS1040	Requires a Gunite clevis kit.
A33-3275N768S	AS1140	
A38-3275A599	AS1038	Requires a Gunite clevis kit.
A38-3275A599	AS1138	
A38-3275U593	AS1038	Requires a Gunite clevis kit.
A38-3275U593	AS1138	
A40-3275A599S	AS1038	Requires a Gunite clevis kit.
A40-3275A599S	AS1138	
A40-3275U593S	AS1038	Requires a Gunite clevis kit.
A40-3275U593S	AS1138	
A41-3275A599S	AS1038	Requires a Gunite clevis kit.
A41-3275A599S	AS1138	

Industry P/N	Gunite Aftermarket P/N	Special Information
<b>Meritor (continued)</b>		
A41-3275U593S	AS1038	Requires a Gunite clevis kit.
A41-3275U593S	AS1138	
A42-3275A599S	AS1032	Requires a Gunite clevis kit.
A42-3275A599S	AS1132	
A42-3275G501	AS1036	Requires a Gunite clevis kit.
A42-3275G501	AS1136	
A42-3275U593S	AS1032	Requires a Gunite clevis kit.
A42-3275U593S	AS1132	
A43-3275A599S	AS1032	Requires a Gunite clevis kit.
A43-3275A599S	AS1132	
A43-3275G501	AS1036	Requires a Gunite clevis kit.
A43-3275G501	AS1136	
A43-3275U593S	AS1032	Requires a Gunite clevis kit.
A43-3275U593S	AS1132	
A44-3275A599S	AS1040	Requires a Gunite clevis kit.
A44-3275A599S	AS1140	
A44-3275U593S	AS1040	Requires a Gunite clevis kit.
A44-3275U593S	AS1140	
A45-3275A599S	AS1043	Requires a Gunite clevis kit.
A45-3275A599S	AS1143	
A45-3275U593S	AS1043	Requires a Gunite clevis kit.
A45-3275U593S	AS1143	
A46-3275A599S	AS1036	Requires a Gunite clevis kit.
A46-3275A599S	AS1136	
A46-3275U593S	AS1036	Requires a Gunite clevis kit.
A46-3275U593S	AS1136	
A47-3275A599S	AS1036	Requires a Gunite clevis kit.
A47-3275A599S	AS1136	
A47-3275U593S	AS1036	Requires a Gunite clevis kit.
A47-3275U593S	AS1136	
A49-3275A599S	AS1032	Requires a Gunite clevis kit.
A49-3275A599S	AS1132	
A49-3275U593S	AS1032	Requires a Gunite clevis kit.
A49-3275U593S	AS1132	
A51-3275A599	AS1038	Requires a Gunite clevis kit.
A51-3275A599	AS1138	
A51-3275U593	AS1038	Requires a Gunite clevis kit.
A51-3275U593	AS1138	
A52-3275A599S	AS1038	Requires a Gunite clevis kit.
A52-3275A599S	AS1138	
A52-3275U593S	AS1038	Requires a Gunite clevis kit.
A52-3275U593S	AS1138	
A53-3275A599	AS1038	Requires a Gunite clevis kit.
A53-3275A599	AS1138	

**Replacement of other brands of slack adjusters should be done in axle sets.** Industry Part Numbers referencing more than a single interchange is the result of Gunite offering the option of ordering its Automatic Slack Adjusters with or without the clevis kit.

## CROSS REFERENCES

### INDUSTRY TO GUNITE

Industry P/N	Gunite Aftermarket P/N	Special Information	Industry P/N	Gunite Aftermarket P/N	Special Information
<b>Meritor (continued)</b>			<b>Meritor (continued)</b>		
A53-3275U593	AS1038	Requires a Gunite clevis kit.	R801040	AS1033	Requires a Gunite clevis kit.
A53-3275U593	AS1138		R801040	AS1133	
A55-3275A599S	AS1038	Requires a Gunite clevis kit.	R801041	AS1032	Requires the use of either AS3000 or AS3016 clevis kits.
A55-3275A599S	AS1138		R801041	AS1132	
A55-3275U593S	AS1038	Requires a Gunite clevis kit.	R801042	AS1033	Requires the use of either AS3000 or AS3016 clevis kits.
A55-3275U593S	AS1138		R801042	AS1133	
A56-3275A599S	AS1040	Requires a Gunite clevis kit.	R801043	AS1032	Requires a Gunite clevis kit.
A56-3275A599S	AS1140		R801043	AS1132	
A56-3275U593S	AS1040	Requires a Gunite clevis kit.	R801044	AS1033	Requires a Gunite clevis kit.
A56-3275U593S	AS1140		R801044	AS1133	
A58-3275A599S	AS1040	Requires a Gunite clevis kit.	R801045	AS1034	Requires a Gunite clevis kit.
A58-3275A599S	AS1140		R801045	AS1134	
A58-3275U593S	AS1040	Requires a Gunite clevis kit.	R801046	AS1031	Requires a Gunite clevis kit.
A58-3275U593S	AS1140		R801046	AS1131	
A59-3275A599S	AS1040	Requires a Gunite clevis kit.	R801047	AS1031	Requires a Gunite clevis kit.
A59-3275A599S	AS1140		R801047	AS1131	
A59-3275U593S	AS1040	Requires a Gunite clevis kit.	R801048	AS1034	Requires a Gunite clevis kit.
A59-3275U593S	AS1140		R801048	AS1134	
A60-3275A599S	AS1032	Requires a Gunite clevis kit.	R801049	AS1033	Requires a Gunite clevis kit.
A60-3275A599S	AS1132		R801049	AS1133	
A60-3275U593S	AS1032	Requires a Gunite clevis kit.	R801050	AS1032	Requires a Gunite clevis kit.
A60-3275U593S	AS1132		R801050	AS1132	
A85-3275G501	AS1036	Requires a Gunite clevis kit.	R801069	AS1041	Requires a Gunite clevis kit.
A85-3275G501	AS1136		R801069	AS1141	
A86-3275G501	AS1036	Requires a Gunite clevis kit.	R801070	AS1040	Requires a Gunite clevis kit.
A86-3275G501	AS1136		R801070	AS1140	
A92-3275G501	AS1031	Requires a Gunite clevis kit. 5.0" arm length only.	R801071	AS1041	Requires a Gunite clevis kit.
A92-3275G501	AS1131	5.0" arm length only.	R801071	AS1141	
A92-3275G501	AS1033	Requires a Gunite clevis kit. 6.0" arm length only.	R801072	AS1040	Requires the use of either AS3000 or AS3016 clevis kits.
A92-3275G501	AS1133	6.0" arm length only.	R801072	AS1140	
B17-3275G501	AS1031	Requires a Gunite clevis kit. 5.0" arm length only.	R801073	AS1040	Requires the use of either AS3000 or AS3016 clevis kits.
B17-3275G501	AS1131	5.0" arm length only.	R801073	AS1140	
B17-3275G501	AS1033	Requires a Gunite clevis kit. 6.0" arm length only.	R801074	AS1041	Requires the use of either AS3000 or AS3016 clevis kits.
B17-3275G501	AS1133	6.0" arm length only.	R801074	AS1141	
R801001	AS1036	Requires the use of either AS3001 or AS3017 clevis kits.	R801075	AS1041	Requires a Gunite clevis kit.
R801001	AS1136		R801075	AS1141	
R801002	AS1038	Requires the use of either AS3001 or AS3017 clevis kits.	R801076	AS1042	Requires a Gunite clevis kit.
R801002	AS1138		R801076	AS1142	
R801004	AS1036	Requires a Gunite clevis kit.	R801077	AS1039	Requires a Gunite clevis kit.
R801004	AS1136		R801077	AS1139	
R801005	AS1036	Requires a Gunite clevis kit.	R801078	AS1039	Requires a Gunite clevis kit.
R801005	AS1136		R801078	AS1139	
R801006	AS1036	Requires a Gunite clevis kit.	R801079	AS1040	Requires the use of either AS3000 or AS3016 clevis kits.
R801006	AS1136		R801079	AS1140	

**Replacement of other brands of stack adjusters should be done in axle sets.** Industry Part Numbers referencing more than a single interchange is the result of Gunite offering the option of ordering its Automatic Slack Adjusters with or without the clevis kit.

## CROSS REFERENCES

### INDUSTRY TO GUNITE

Industry P/N	Gunite Aftermarket P/N	Special Information
<b>Meritor (continued)</b>		
R801080	AS1040	Requires a Gunite clevis kit.
R801080	AS1140	
R801081	AS1042	Requires a Gunite clevis kit.
R801081	AS1142	
R801082	AS1040	Requires a Gunite clevis kit.
R801082	AS1140	
R801083	AS1040	Requires a Gunite clevis kit.
R801083	AS1140	
R801084	AS1040	Requires a Gunite clevis kit.
R801084	AS1140	
R801085	AS1040	Requires a Gunite clevis kit.
R801085	AS1140	
R801086	AS1041	Requires a Gunite clevis kit.
R801086	AS1141	
R801087	AS1041	Requires a Gunite clevis kit.
R801087	AS1141	
R801088	AS1040	Requires a Gunite clevis kit.
R801088	AS1140	
R801100	AS1044	Requires a Gunite clevis kit.
R801100	AS1144	
R801101	AS1043	Requires the use of either AS3000 or AS3016 clevis kits.
R801101	AS1143	
R801102	AS1044	Requires the use of either AS3000 or AS3016 clevis kits.
R801102	AS1144	
R802000	AS1035	Requires a Gunite clevis kit.
R802000	AS1135	
R802001	AS1035	Requires a Gunite clevis kit.
R802001	AS1135	
R802002	AS1035	Requires a Gunite clevis kit.
R802002	AS1135	
R802003	AS1035	Requires a Gunite clevis kit.
R802003	AS1135	
R802008	AS1035	Requires a Gunite clevis kit.
R802008	AS1135	
R802009	AS1035	Requires a Gunite clevis kit.
R802009	AS1135	
R802020	AS1036	Requires a Gunite clevis kit.
R802020	AS1136	
R802021	AS1036	Requires a Gunite clevis kit.
R802021	AS1136	
R802022	AS1036	Requires a Gunite clevis kit.
R802022	AS1136	
R802023	AS1036	Requires a Gunite clevis kit.
R802023	AS1136	

Industry P/N	Gunite Aftermarket P/N	Special Information
<b>Meritor (continued)</b>		
R802030	AS1036	Requires a Gunite clevis kit.
R802030	AS1136	
R802031	AS1036	Requires a Gunite clevis kit.
R802031	AS1136	
R802032	AS1036	Requires a Gunite clevis kit.
R802032	AS1136	
R802033	AS1036	Requires a Gunite clevis kit.
R802033	AS1136	
R802040	AS1036	Requires a Gunite clevis kit.
R802040	AS1136	
R802041	AS1036	Requires a Gunite clevis kit.
R802041	AS1136	
R802042	AS1036	Requires a Gunite clevis kit.
R802042	AS1136	
R802043	AS1036	Requires a Gunite clevis kit.
R802043	AS1136	
R802044	AS1036	Requires a Gunite clevis kit.
R802044	AS1136	
R802045	AS1036	Requires a Gunite clevis kit.
R802045	AS1136	
R802050	AS1038	Requires a Gunite clevis kit.
R802050	AS1138	
R802051	AS1038	Requires a Gunite clevis kit.
R802051	AS1138	
R802052	AS1038	Requires a Gunite clevis kit.
R802052	AS1138	
R802053	AS1038	Requires a Gunite clevis kit.
R802053	AS1138	
R802060	AS1038	Requires a Gunite clevis kit.
R802060	AS1138	
R802061	AS1038	Requires a Gunite clevis kit.
R802061	AS1138	
R802062	AS1038	Requires a Gunite clevis kit.
R802062	AS1138	
R802063	AS1038	Requires a Gunite clevis kit.
R802063	AS1138	
R802070	AS1038	Requires the use of either AS3000 or AS3016 clevis kits.
R802070	AS1138	
R802071	AS1038	Requires the use of either AS3000 or AS3016 clevis kits.
R802071	AS1138	
R802072	AS1038	Requires a Gunite clevis kit.
R802072	AS1138	
R802073	AS1038	Requires a Gunite clevis kit.
R802073	AS1138	

**Replacement of other brands of slack adjusters should be done in axle sets.** Industry Part Numbers referencing more than a single interchange is the result of Gunite offering the option of ordering its Automatic Slack Adjusters with or without the clevis kit.

## CROSS REFERENCES

### INDUSTRY TO GUNITE

Industry P/N	Gunite Aftermarket P/N	Special Information
<b>Meritor (continued)</b>		
R802074	AS1038	Requires a Gunite clevis kit.
R802074	AS1138	
R802075	AS1038	Requires a Gunite clevis kit.
R802075	AS1138	
R802260	AS1031	Requires a Gunite clevis kit.
R802260	AS1131	
R802261	AS1031	Requires a Gunite clevis kit.
R802261	AS1131	
R802262	AS1031	Requires a Gunite clevis kit.
R802262	AS1131	
R802263	AS1031	Requires a Gunite clevis kit.
R802263	AS1131	
R802270	AS1031	Requires a Gunite clevis kit.
R802270	AS1131	
R802271	AS1031	Requires a Gunite clevis kit.
R802271	AS1131	
R802276	AS1031	Requires a Gunite clevis kit.
R802276	AS1131	
R802277	AS1031	Requires a Gunite clevis kit.
R802277	AS1131	
R802280	AS1031	Requires a Gunite clevis kit.
R802280	AS1131	
R802281	AS1031	Requires a Gunite clevis kit.
R802281	AS1131	
R802290	AS1032	Requires a Gunite clevis kit.
R802290	AS1132	
R802291	AS1032	Requires a Gunite clevis kit.
R802291	AS1132	
R802292	AS1032	Requires a Gunite clevis kit.
R802292	AS1132	
R802293	AS1032	Requires a Gunite clevis kit.
R802293	AS1132	
R802300	AS1032	Requires a Gunite clevis kit.
R802300	AS1132	
R802301	AS1032	Requires a Gunite clevis kit.
R802301	AS1132	
R802302	AS1032	Requires a Gunite clevis kit.
R802302	AS1132	
R802303	AS1032	Requires a Gunite clevis kit.
R802303	AS1132	
R802310	AS1032	Requires a Gunite clevis kit.
R802310	AS1132	
R802311	AS1032	Requires a Gunite clevis kit.
R802311	AS1132	

Industry P/N	Gunite Aftermarket P/N	Special Information
<b>Meritor (continued)</b>		
R802312	AS1032	Requires a Gunite clevis kit.
R802312	AS1132	
R802313	AS1032	Requires a Gunite clevis kit.
R802313	AS1132	
R802314	AS1032	Requires a Gunite clevis kit.
R802314	AS1132	
R802315	AS1032	Requires a Gunite clevis kit.
R802315	AS1132	
R802316	AS1032	Requires the use of either AS3000 or AS3016 clevis kits.
R802316	AS1132	
R802317	AS1032	Requires the use of either AS3000 or AS3016 clevis kits.
R802317	AS1132	
R802318	AS1032	Requires a Gunite clevis kit.
R802318	AS1132	
R802319	AS1032	Requires a Gunite clevis kit.
R802319	AS1132	
R802320	AS1032	Requires a Gunite clevis kit.
R802320	AS1132	
R802321	AS1032	Requires a Gunite clevis kit.
R802321	AS1132	
R802330	AS1032	Requires a Gunite clevis kit.
R802330	AS1132	
R802331	AS1032	Requires a Gunite clevis kit.
R802331	AS1132	
R802332	AS1032	Requires the use of either AS3000 or AS3016 clevis kits.
R802332	AS1132	
R802333	AS1032	Requires the use of either AS3000 or AS3016 clevis kits.
R802333	AS1132	
R802350	AS1033	Requires a Gunite clevis kit.
R802350	AS1133	
R802351	AS1033	Requires a Gunite clevis kit.
R802351	AS1133	
R802354	AS1033	Requires a Gunite clevis kit.
R802354	AS1133	
R802355	AS1033	Requires a Gunite clevis kit.
R802355	AS1133	
R802356	AS1033	Requires a Gunite clevis kit.
R802356	AS1133	
R802357	AS1033	Requires a Gunite clevis kit.
R802357	AS1133	
R802360	AS1034	Requires a Gunite clevis kit.
R802360	AS1134	
R802361	AS1034	Requires a Gunite clevis kit.
R802361	AS1134	

**Replacement of other brands of slack adjusters should be done in axle sets.** Industry Part Numbers referencing more than a single interchange is the result of Gunite offering the option of ordering its Automatic Slack Adjusters with or without the clevis kit.

Features and Benefits

Numerical Listings

Axle Applications

Obsolete Products

Cross References



## CROSS REFERENCES

### INDUSTRY TO GUNITE

Industry P/N	Gunite Aftermarket P/N	Special Information
<b>Meritor (continued)</b>		
R802362	AS1034	Requires a Gunite clevis kit.
R802362	AS1134	
R802363	AS1034	Requires a Gunite clevis kit.
R802363	AS1134	
R802370	AS1034	Requires a Gunite clevis kit.
R802370	AS1134	
R802371	AS1034	Requires a Gunite clevis kit.
R802371	AS1134	
R802400	AS1039	Requires a Gunite clevis kit.
R802400	AS1139	
R802401	AS1039	Requires a Gunite clevis kit.
R802401	AS1139	
R802402	AS1039	Requires a Gunite clevis kit.
R802402	AS1139	
R802403	AS1039	Requires a Gunite clevis kit.
R802403	AS1139	
R802410	AS1039	Requires a Gunite clevis kit.
R802410	AS1139	
R802411	AS1039	Requires a Gunite clevis kit.
R802411	AS1139	
R802412	AS1039	Requires a Gunite clevis kit.
R802412	AS1139	
R802413	AS1039	Requires a Gunite clevis kit.
R802413	AS1139	
R802414	AS1039	Requires a Gunite clevis kit.
R802414	AS1139	
R802415	AS1039	Requires a Gunite clevis kit.
R802415	AS1139	
R802416	AS1039	Requires a Gunite clevis kit.
R802416	AS1139	
R802417	AS1039	Requires a Gunite clevis kit.
R802417	AS1139	
R802420	AS1040	Requires a Gunite clevis kit.
R802420	AS1140	
R802421	AS1040	Requires a Gunite clevis kit.
R802421	AS1140	
R802422	AS1040	Requires a Gunite clevis kit.
R802422	AS1140	
R802423	AS1040	Requires a Gunite clevis kit.
R802423	AS1140	
R802430	AS1040	Requires a Gunite clevis kit.
R802430	AS1140	
R802431	AS1040	Requires a Gunite clevis kit.
R802431	AS1140	

Industry P/N	Gunite Aftermarket P/N	Special Information
<b>Meritor (continued)</b>		
R802432	AS1040	Requires a Gunite clevis kit.
R802432	AS1140	
R802433	AS1040	Requires a Gunite clevis kit.
R802433	AS1140	
R802440	AS1040	Requires a Gunite clevis kit.
R802440	AS1140	
R802441	AS1040	Requires a Gunite clevis kit.
R802441	AS1140	
R802442	AS1040	Requires a Gunite clevis kit.
R802442	AS1140	
R802443	AS1040	Requires a Gunite clevis kit.
R802443	AS1140	
R802444	AS1040	Requires the use of either AS3000 or AS3016 clevis kits.
R802444	AS1140	
R802445	AS1040	Requires the use of either AS3000 or AS3016 clevis kits.
R802445	AS1140	
R802446	AS1040	Requires the use of either AS3000 or AS3016 clevis kits.
R802446	AS1140	
R802447	AS1040	Requires the use of either AS3000 or AS3016 clevis kits.
R802447	AS1140	
R802448	AS1040	Requires a Gunite clevis kit.
R802448	AS1140	
R802449	AS1040	Requires a Gunite clevis kit.
R802449	AS1140	
R802450	AS1040	Requires a Gunite clevis kit.
R802450	AS1140	
R802451	AS1040	Requires a Gunite clevis kit.
R802451	AS1140	
R802452	AS1040	Requires a Gunite clevis kit.
R802452	AS1140	
R802453	AS1040	Requires a Gunite clevis kit.
R802453	AS1140	
R802462	AS1040	Requires the use of either AS3000 or AS3016 clevis kits.
R802462	AS1140	
R802463	AS1040	Requires the use of either AS3000 or AS3016 clevis kits.
R802463	AS1140	
R802470	AS1040	Requires a Gunite clevis kit.
R802470	AS1140	
R802471	AS1040	Requires a Gunite clevis kit.
R802471	AS1140	
R802480	AS1041	Requires a Gunite clevis kit.
R802480	AS1141	
R802481	AS1041	Requires a Gunite clevis kit.
R802481	AS1141	

**Replacement of other brands of slack adjusters should be done in axle sets.** Industry Part Numbers referencing more than a single interchange is the result of Gunite offering the option of ordering its Automatic Slack Adjusters with or without the clevis kit.

# CROSS REFERENCES

## INDUSTRY TO GUNITE

Industry P/N	Gunite Aftermarket P/N	Special Information
<b>Meritor (continued)</b>		
R802482	AS1041	Requires a Gunite clevis kit.
R802482	AS1141	
R802483	AS1041	Requires a Gunite clevis kit.
R802483	AS1141	
R802486	AS1041	Requires the use of either AS3000 or AS3016 clevis kits.
R802486	AS1141	
R802487	AS1041	Requires the use of either AS3000 or AS3016 clevis kits.
R802487	AS1141	
R802488	AS1041	Requires a Gunite clevis kit.
R802488	AS1141	
R802489	AS1041	Requires a Gunite clevis kit.
R802489	AS1141	
R802490	AS1041	Requires the use of either AS3000 or AS3016 clevis kits.
R802490	AS1141	
R802491	AS1041	Requires the use of either AS3000 or AS3016 clevis kits.
R802491	AS1141	
R802492	AS1041	Requires a Gunite clevis kit.
R802492	AS1141	
R802493	AS1041	Requires a Gunite clevis kit.
R802493	AS1141	
R802500	AS1042	Requires a Gunite clevis kit.
R802500	AS1142	
R802501	AS1042	Requires a Gunite clevis kit.
R802501	AS1142	
R802502	AS1042	Requires a Gunite clevis kit.
R802502	AS1142	
R802503	AS1042	Requires a Gunite clevis kit.
R802503	AS1142	
R802504	AS1042	Requires a Gunite clevis kit.
R802504	AS1142	
R802505	AS1042	Requires a Gunite clevis kit.
R802505	AS1142	
R802510	AS1042	Requires a Gunite clevis kit.
R802510	AS1142	
R802511	AS1042	Requires a Gunite clevis kit.
R802511	AS1142	
R802512	AS1042	Requires the use of either AS3000 or AS3016 clevis kits.
R802512	AS1142	
R802513	AS1042	Requires the use of either AS3000 or AS3016 clevis kits.
R802513	AS1142	
R802610	AS1043	Requires a Gunite clevis kit.
R802610	AS1143	
R802611	AS1043	Requires a Gunite clevis kit.
R802611	AS1143	

Industry P/N	Gunite Aftermarket P/N	Special Information
<b>Haldex Brake Systems - Midland</b>		
R802616	AS1044	Requires a Gunite clevis kit.
R802616	AS1144	
R802617	AS1044	Requires a Gunite clevis kit.
R802617	AS1144	
R802620	AS1044	Requires a Gunite clevis kit.
R802620	AS1144	
R802621	AS1044	Requires a Gunite clevis kit.
R802621	AS1144	
R802630	AS1045	Requires a Gunite clevis kit.
R802630	AS1145	
R802631	AS1045	Requires a Gunite clevis kit.
R802631	AS1145	
R802666	AS1032	Requires the use of either AS3000 or AS3016 clevis kits.
R802666	AS1032	
R802667	AS1032	Requires the use of either AS3000 or AS3016 clevis kits.
R802667	AS1132	
C365930	AS4015	
CQ19112	AS4006	
CQ19113	AS4004	
CQ36541	AS3000	
CQ36544	AS3016	
CQ36545	AS3018	
CQ36551	AS3001	
CQ36555	AS3017	
CQ36561	AS3003	
CQ36563	AS3012	
CQ36564	AS3011	
CQ36571	AS3002	
CQ36591	AS3013	
CQ36592	AS4001	
CQ36593	AS3019	
CS52315	AS1031	Crewson Industries ASA. Requires the use of either AS3000 or AS3016 clevis kits. 5.0" arm length only.
CS52315	AS1131	Crewson Industries ASA. 5.0" arm length only.
CS52315	AS1033	Crewson Industries ASA. Requires the use of either AS3000 or AS3016 clevis kits. 6.0" arm length only.
CS52315	AS1133	Crewson Industries ASA. 6.0" arm length only.
CS52316	AS1032	Crewson Industries ASA. Requires the use of either AS3000 or AS3016 clevis kits. 5.5" arm length only.
CS52316	AS1132	Crewson Industries ASA. 5.5" arm length only.
CS52316	AS1034	Crewson Industries ASA. Requires the use of either AS3000 or AS3016 clevis kits. 6.5" arm length only.
CS52316	AS1134	Crewson Industries ASA. 6.5" arm length only.
CS52317	AS1033	Crewson Industries ASA. Requires the use of either AS3000 or AS3016 clevis kits. 6.0" arm length only.
CS52317	AS1133	Crewson Industries ASA. 6.0" arm length only.
CS52320	AS1040	Crewson Industries ASA. Requires the use of either AS3000 or AS3016 clevis kits. 5.5" arm length only.

**Replacement of other brands of slack adjusters should be done in axle sets.** Industry Part Numbers referencing more than a single interchange is the result of Gunite offering the option of ordering its Automatic Slack Adjusters with or without the clevis kit.

Features and Benefits

Numerical Listings

Axle Applications

Obsolete Products

Cross References

## CROSS REFERENCES

### INDUSTRY TO GUNITE

Industry P/N	Gunite Aftermarket P/N	Special Information
<b>Haldex Brake Systems - Midland (continued)</b>		
CS52320	AS1140	Crewson Industries ASA. 5.5" arm length only.
CS52320	AS1042	Crewson Industries ASA. Requires the use of either AS3000 or AS3016 clevis kits. 6.5" arm length only.
CS52320	AS1142	Crewson Industries ASA. 6.5" arm length only.
CS52321	AS1039	Crewson Industries ASA. Requires the use of either AS3000 or AS3016 clevis kits. 5.0" arm length only.
CS52321	AS1139	Crewson Industries ASA. 5.0" arm length only.
CS52321	AS1041	Crewson Industries ASA. Requires the use of either AS3000 or AS3016 clevis kits. 6.0" arm length only.
CS52321	AS1141	Crewson Industries ASA. 6.0" arm length only.
CS52322	AS1041	Crewson Industries ASA. Requires the use of either AS3000 or AS3016 clevis kits. 6.0" arm length only.
CS52322	AS1141	Crewson Industries ASA. 6.0" arm length only.
CS52325	AS1043	Crewson Industries ASA. Requires the use of either AS3000 or AS3016 clevis kits. 5.5" arm length only.
CS52325	AS1143	Crewson Industries ASA. 5.5" arm length only.
CS52326	AS1044	Crewson Industries ASA. Requires the use of either AS3000 or AS3016 clevis kits.
CS52326	AS1144	Crewson Industries ASA.
CS52330	AS1036	Crewson Industries ASA. Requires the use of either AS3000 or AS3016 clevis kits. 5.5" arm length only.
CS52330	AS1136	Crewson Industries ASA. 5.5" arm length only.
CS52331	AS1036	Crewson Industries ASA. Requires the use of AS3003 clevis kit.
CS52332	AS1035	Crewson Industries ASA. Requires the use of either AS3000 or AS3016 clevis kits. 5.0" arm length only.
CS52332	AS1135	Crewson Industries ASA. 5.0" arm length only.
CS52335	AS1038	Crewson Industries ASA. Requires the use of either AS3000 or AS3016 clevis kits. 5.5" arm length only.
CS52335	AS1138	Crewson Industries ASA. 5.5" arm length only.
CS52336	AS1038	Crewson Industries ASA. Requires the use of AS3003 clevis kit.
CS52337	AS1037	Crewson Industries ASA. Requires the use of either AS3000 or AS3016 clevis kits. 5.0" arm length only.
CS52337	AS1137	Crewson Industries ASA. 5.0" arm length only.
CS52344	AS1033	Crewson Industries ASA. Requires the use of either AS3000 or AS3016 clevis kits. 6.0" arm length only.
CS52344	AS1133	Crewson Industries ASA. 6.0" arm length only.
CS52345	AS1041	Crewson Industries ASA. Requires the use of either AS3000 or AS3016 clevis kits. 6.0" arm length only.
CS52345	AS1141	Crewson Industries ASA. 6.0" arm length only.
CS52346	AS1032	Crewson Industries ASA. Requires the use of either AS3000 or AS3016 clevis kits.
CS52346	AS1132	Crewson Industries ASA.
CS52347	AS1040	Crewson Industries ASA. Requires the use of either AS3000 or AS3016 clevis kits.
CS52347	AS1140	Crewson Industries ASA.
CS52348	AS1033	Crewson Industries ASA. Requires the use of either AS3000 or AS3016 clevis kits.
CS52348	AS1133	Crewson Industries ASA.
CS52349	AS1041	Crewson Industries ASA. Requires the use of either AS3000 or AS3016 clevis kits.
CS52349	AS1141	Crewson Industries ASA.
CS52350	AS1044	Crewson Industries ASA. Requires the use of either AS3000 or AS3016 clevis kits.
CS52350	AS1144	Crewson Industries ASA.
CS52353	AS1033	Crewson Industries ASA. Requires the use of either AS3000 or AS3016 clevis kits. 6.0" arm length only.

Industry P/N	Gunite Aftermarket P/N	Special Information
<b>Haldex Brake Systems - Midland (continued)</b>		
CS52353	AS1133	Crewson Industries ASA. 6.0" arm length only.
CS52354	AS1032	Crewson Industries ASA. Requires the use of either AS3000 or AS3016 clevis kits. 5.5" arm length only.
CS52354	AS1132	Crewson Industries ASA. 5.5" arm length only.
CS52354	AS1034	Crewson Industries ASA. Requires the use of either AS3000 or AS3016 clevis kits. 6.5" arm length only.
CS52354	AS1134	Crewson Industries ASA. 6.5" arm length only.
CS52355	AS1039	Crewson Industries ASA. Requires the use of either AS3000 or AS3016 clevis kits. 5.0" arm length only.
CS52355	AS1139	Crewson Industries ASA. 5.0" arm length only.
CS52355	AS1041	Crewson Industries ASA. Requires the use of either AS3000 or AS3016 clevis kits. 6.0" arm length only.
CS52355	AS1141	Crewson Industries ASA. 6.0" arm length only.
CS52356	AS1040	Crewson Industries ASA. Requires the use of either AS3000 or AS3016 clevis kits. 5.5" arm length only.
CS52356	AS1140	Crewson Industries ASA. 5.5" arm length only.
CS52356	AS1042	Crewson Industries ASA. Requires the use of either AS3000 or AS3016 clevis kits. 6.5" arm length only.
CS52356	AS1142	Crewson Industries ASA. 6.5" arm length only.
CS52357	AS1043	Crewson Industries ASA. Requires the use of either AS3000 or AS3016 clevis kits.
CS52357	AS1143	Crewson Industries ASA.
CS52358	AS1036	Crewson Industries ASA. Requires the use of either AS3000 or AS3016 clevis kits.
CS52358	AS1136	Crewson Industries ASA.
CS52359	AS1038	Crewson Industries ASA. Requires the use of either AS3000 or AS3016 clevis kits.
CS52359	AS1138	Crewson Industries ASA.
CS52360	AS1036	Crewson Industries ASA. Requires the use of either AS3000 or AS3016 clevis kits.
CS52360	AS1136	Crewson Industries ASA.
CS52361	AS1038	Crewson Industries ASA. Requires the use of either AS3001 or AS3017 clevis kits.
CS52361	AS1138	Crewson Industries ASA.
CS52362	AS1032	Crewson Industries ASA. Requires the use of either AS3000 or AS3016 clevis kits.
CS52362	AS1132	Crewson Industries ASA.
CS52363	AS1033	Crewson Industries ASA. Requires the use of either AS3000 or AS3016 clevis kits.
CS52363	AS1133	Crewson Industries ASA.
CS52364	AS1040	Crewson Industries ASA. Requires the use of either AS3000 or AS3016 clevis kits.
CS52364	AS1140	Crewson Industries ASA.
CS52365	AS1041	Crewson Industries ASA. Requires the use of either AS3000 or AS3016 clevis kits.
CS52365	AS1141	Crewson Industries ASA.
CS52366	AS1044	Crewson Industries ASA. Requires the use of either AS3000 or AS3016 clevis kits.
CS52366	AS1144	Crewson Industries ASA.
CS56000	AS1034	Requires a Gunite clevis kit.
CS56000	AS1134	
CS56001	AS1042	Requires a Gunite clevis kit.
CS56001	AS1142	
CS56002	AS1045	Requires a Gunite clevis kit.
CS56002	AS1145	

**Replacement of other brands of slack adjusters should be done in axle sets.** Industry Part Numbers referencing more than a single interchange is the result of Gunite offering the option of ordering its Automatic Slack Adjusters with or without the clevis kit.

## CROSS REFERENCES

### INDUSTRY TO GUNITE

Industry P/N	Gunite Aftermarket P/N	Special Information
<b>Haldex Brake Systems - Midland (continued)</b>		
CS56003	AS1033	Requires a Gunite clevis kit
CS56003	AS1133	
CS56004	AS1041	Requires a Gunite clevis kit
CS56004	AS1141	
CS56005	AS1044	Requires a Gunite clevis kit
CS56005	AS1144	
CS56006	AS1032	Requires a Gunite clevis kit
CS56006	AS1132	
CS56007	AS1040	Requires a Gunite clevis kit
CS56007	AS1140	
CS56008	AS1043	Requires a Gunite clevis kit
CS56008	AS1143	
CS56009	AS1035	Requires a Gunite clevis kit
CS56009	AS1135	
CS56010	AS1031	Requires a Gunite clevis kit
CS56010	AS1131	
CS56011	AS1037	Requires a Gunite clevis kit
CS56011	AS1137	
CS56012	AS1039	Requires a Gunite clevis kit
CS56012	AS1139	
CS56013	AS1036	Requires a Gunite clevis kit
CS56013	AS1136	
CS56014	AS1038	Requires a Gunite clevis kit
CS56014	AS1138	
CS56031	AS1131	
CS56032	AS1132	
CS56033	AS1133	
CS56034	AS1134	
CS56035	AS1135	
CS56036	AS1136	
CS56037	AS1137	
CS56038	AS1138	
CS56039	AS1139	
CS56040	AS1140	
CS56041	AS1141	
CS56042	AS1142	
CS56043	AS1143	
CS56044	AS1144	
CS56045	AS1145	
CS56046	AS1146	
CS56047	AS1147	
CS56048	AS1148	
CS56049	AS1149	
CS56050	AS1150	

Industry P/N	Gunite Aftermarket P/N	Special Information
<b>Haldex Brake Systems - Midland (continued)</b>		
CS56051	AS1151	
CS56052	AS1152	
CS56053	AS1153	
CS56054	AS1154	
CS56055	AS1155	
CS56056	AS1156	
CS56057	AS1157	
KN36540	AS3000	
KN36550	AS3001	
KN36560	AS3003	
KN36570	AS3002	
KN36580	AS4001	
KN36581	AS4009	
KN44041	AS1044	Requires a Gunite clevis kit
KN44041	AS1144	
KN44051	AS1041	Requires a Gunite clevis kit
KN44051	AS1141	
KN44061	AS1040	Requires a Gunite clevis kit. 5.5" arm length only.
KN44061	AS1140	5.5" arm length only.
KN44061	AS1042	Requires a Gunite clevis kit. 6.5" arm length only.
KN44061	AS1142	6.5" arm length only.
KN47001	AS1033	Requires a Gunite clevis kit
KN47001	AS1133	
KN47011	AS1032	Requires a Gunite clevis kit. 5.5" arm length only.
KN47011	AS1132	5.5" arm length only.
KN47011	AS1034	Requires a Gunite clevis kit. 6.5" arm length only.
KN47011	AS1134	6.5" arm length only.
KN47081	AS1033	Requires a Gunite clevis kit
KN47081	AS1133	
KN48031	AS1036	Requires a Gunite clevis kit
KN48031	AS1136	
KN52200	AS1033	Requires a Gunite clevis kit
KN52200	AS1133	
KN52201	AS1033	Requires a Gunite clevis kit
KN52201	AS1133	
KN52202	AS1033	Requires a Gunite clevis kit
KN52202	AS1133	
KN52203	AS1033	Requires a Gunite clevis kit
KN52203	AS1133	
KN52204	AS1033	Requires a Gunite clevis kit
KN52204	AS1133	
KN52210	AS1041	Requires a Gunite clevis kit
KN52210	AS1141	
KN52211	AS1041	Requires a Gunite clevis kit

**Replacement of other brands of slack adjusters should be done in axle sets.** Industry Part Numbers referencing more than a single interchange is the result of Gunite offering the option of ordering its Automatic Slack Adjusters with or without the clevis kit.

Features and Benefits

Numerical Listings

Axle Applications

Obsolete Products

Cross References



## CROSS REFERENCES

### INDUSTRY TO GUNITE

Industry P/N	Gunite Aftermarket P/N	Special Information
<b>Haldex Brake Systems - Midland (continued)</b>		
KN52211	AS1141	
KN52212	AS1041	Requires a Gunite clevis kit
KN52212	AS1141	
KN52213	AS1041	Requires a Gunite clevis kit
KN52213	AS1141	
KN52214	AS1041	Requires a Gunite clevis kit
KN52214	AS1141	
KN52220	AS1044	Requires a Gunite clevis kit
KN52220	AS1144	
KN52221	AS1044	Requires a Gunite clevis kit
KN52221	AS1144	
KN52222	AS1044	Requires a Gunite clevis kit
KN52222	AS1144	
KN52223	AS1044	Requires a Gunite clevis kit
KN52223	AS1144	
KN52224	AS1044	Requires a Gunite clevis kit
KN52224	AS1144	
KN52230	AS1032	Requires a Gunite clevis kit. 5.5" arm length only.
KN52230	AS1132	5.5" arm length only.
KN52230	AS1034	Requires a Gunite clevis kit. 6.5" arm length only.
KN52230	AS1134	6.5" arm length only.
KN52231	AS1032	Requires a Gunite clevis kit. 5.5" arm length only.
KN52231	AS1132	5.5" arm length only.
KN52231	AS1034	Requires a Gunite clevis kit. 6.5" arm length only.
KN52231	AS1134	6.5" arm length only.
KN52232	AS1032	Requires a Gunite clevis kit. 5.5" arm length only.
KN52232	AS1132	5.5" arm length only.
KN52232	AS1034	Requires a Gunite clevis kit. 6.5" arm length only.
KN52232	AS1134	6.5" arm length only.
KN52233	AS1032	Requires a Gunite clevis kit. 5.5" arm length only.
KN52233	AS1132	5.5" arm length only.
KN52233	AS1034	Requires a Gunite clevis kit. 6.5" arm length only.
KN52233	AS1134	6.5" arm length only.
KN52234	AS1032	Requires a Gunite clevis kit. 5.5" arm length only.
KN52234	AS1132	5.5" arm length only.
KN52234	AS1034	Requires a Gunite clevis kit. 6.5" arm length only.
KN52234	AS1134	6.5" arm length only.
KN52240	AS1040	Requires a Gunite clevis kit. 5.5" arm length only.
KN52240	AS1140	5.5" arm length only.
KN52240	AS1042	Requires a Gunite clevis kit. 6.5" arm length only.
KN52240	AS1142	6.5" arm length only.
KN52241	AS1040	Requires a Gunite clevis kit. 5.5" arm length only.
KN52241	AS1140	5.5" arm length only.
KN52241	AS1042	Requires a Gunite clevis kit. 6.5" arm length only.

Industry P/N	Gunite Aftermarket P/N	Special Information
<b>Haldex Brake Systems - Midland (continued)</b>		
KN52241	AS1142	6.5" arm length only.
KN52242	AS1040	Requires a Gunite clevis kit. 5.5" arm length only.
KN52242	AS1140	5.5" arm length only.
KN52242	AS1042	Requires a Gunite clevis kit. 6.5" arm length only.
KN52242	AS1142	6.5" arm length only.
KN52243	AS1040	Requires a Gunite clevis kit. 5.5" arm length only.
KN52243	AS1140	5.5" arm length only.
KN52243	AS1042	Requires a Gunite clevis kit. 6.5" arm length only.
KN52243	AS1142	6.5" arm length only.
KN52244	AS1040	Requires a Gunite clevis kit. 5.5" arm length only.
KN52244	AS1140	5.5" arm length only.
KN52244	AS1042	Requires a Gunite clevis kit. 6.5" arm length only.
KN52244	AS1142	6.5" arm length only.
KN52250	AS1036	Requires a Gunite clevis kit
KN52250	AS1136	
KN52251	AS1036	Requires a Gunite clevis kit
KN52251	AS1136	
KN52252	AS1036	Requires a Gunite clevis kit
KN52252	AS1136	
KN52253	AS1036	Requires a Gunite clevis kit
KN52253	AS1136	
KN52254	AS1036	Requires a Gunite clevis kit
KN52254	AS1136	
KN52260	AS1043	Requires a Gunite clevis kit. 5.5" arm length only.
KN52260	AS1143	5.5" arm length only.
KN52260	AS1045	Requires a Gunite clevis kit. 6.5" arm length only.
KN52260	AS1145	6.5" arm length only.
KN52261	AS1043	Requires a Gunite clevis kit. 5.5" arm length only.
KN52261	AS1143	5.5" arm length only.
KN52261	AS1045	Requires a Gunite clevis kit. 6.5" arm length only.
KN52261	AS1145	6.5" arm length only.
KN52262	AS1043	Requires a Gunite clevis kit. 5.5" arm length only.
KN52262	AS1143	5.5" arm length only.
KN52262	AS1045	Requires a Gunite clevis kit. 6.5" arm length only.
KN52262	AS1145	6.5" arm length only.
KN52263	AS1043	Requires a Gunite clevis kit. 5.5" arm length only.
KN52263	AS1143	5.5" arm length only.
KN52263	AS1045	Requires a Gunite clevis kit. 6.5" arm length only.
KN52263	AS1145	6.5" arm length only.
KN52264	AS1043	Requires a Gunite clevis kit. 5.5" arm length only.
KN52264	AS1143	5.5" arm length only.
KN52264	AS1045	Requires a Gunite clevis kit. 6.5" arm length only.
KN52264	AS1145	6.5" arm length only.
KN52270	AS1038	Requires a Gunite clevis kit

**Replacement of other brands of slack adjusters should be done in axle sets.** Industry Part Numbers referencing more than a single interchange is the result of Gunite offering the option of ordering its Automatic Slack Adjusters with or without the clevis kit.

## CROSS REFERENCES

### INDUSTRY TO GUNITE

Industry P/N	Gunite Aftermarket P/N	Special Information
<b>Haldex Brake Systems - Midland (continued)</b>		
KN52270	AS1138	
KN52271	AS1038	Requires a Gunite clevis kit
KN52271	AS1138	
KN52272	AS1038	Requires a Gunite clevis kit
KN52272	AS1138	
KN52273	AS1038	Requires a Gunite clevis kit
KN52273	AS1138	
KN52274	AS1038	Requires a Gunite clevis kit
KN52274	AS1138	
KN52280	AS1035	Requires a Gunite clevis kit
KN52280	AS1135	
KN52290	AS1031	Requires a Gunite clevis kit
KN52290	AS1131	
KN52300	AS1037	Requires a Gunite clevis kit
KN52300	AS1137	
KN52310	AS1039	Requires a Gunite clevis kit
KN52310	AS1139	
N12684C	AS1040	Requires a Gunite clevis kit
N12684C	AS1140	
<b>Sloan</b>		
2010	AS1031	Requires a Gunite clevis kit. 5.0" arm length only.
2010	AS1131	5.0" arm length only.
2010	AS1033	Requires a Gunite clevis kit. 6.0" arm length only.
2010	AS1133	6.0" arm length only.
2011	AS1039	Requires a Gunite clevis kit. 5.0" arm length only.
2011	AS1139	5.0" arm length only.
2011	AS1041	Requires a Gunite clevis kit. 6.0" arm length only.
2011	AS1141	6.0" arm length only.
2012	AS1044	Requires a Gunite clevis kit.
2012	AS1144	
2014	AS1031	Requires a Gunite clevis kit. 5.0" arm length only.
2014	AS1131	5.0" arm length only.
2014	AS1033	Requires a Gunite clevis kit. 6.0" arm length only.
2014	AS1133	6.0" arm length only.
2020	AS1032	Requires a Gunite clevis kit. 5.5" arm length only.
2020	AS1132	5.5" arm length only.
2020	AS1034	6.5" arm length only.
2020	AS1134	6.5" arm length only.
2035	AS1035	Requires a Gunite clevis kit.
2035	AS1135	
2045	AS1033	Requires a Gunite clevis kit.
2045	AS1133	
2046	AS1033	Requires a Gunite clevis kit.
2046	AS1133	

**Replacement of other brands of slack adjusters should be done in axle sets.** Industry Part Numbers referencing more than a single interchange is the result of Gunite offering the option of ordering its Automatic Slack Adjusters with or without the clevis kit.







**Your only single source for industry-leading wheel end solutions.**  
STEEL & ALUMINUM WHEELS | DRUMS | HUBS | ROTORS | SLACK ADJUSTERS

**(800) 677-3786 | (815) 964-3301 | [accuridecorp.com](http://accuridecorp.com)**

**Gunite | 302 Peoples Avenue | Rockford, IL 61104-7092**