

# PRODUCT CATALOG

---

ENGINE HEATERS  
OIL HEATERS  
CONTROLS  
ACCESSORIES



HOTSTART® 

# TABLE OF CONTENTS

## HOTflow® ONLINE TECHNICIAN CERTIFICATION TRAINING

- Page 7

## HEATER INSTALLATION

- Page 18 (Thermosiphon)
- Page 47 (In-block)

## HOW TO SPECIFY AN ENGINE HEATER

- Page 50

## CONVERSION CHARTS

- Page 50

## CUSTOM PRODUCTS

Call for information on:

- Wiring Harnesses
- APUs
- Forced Circulation Heating Systems
- Other Specialty Products

- 1** PAGES 4 - 6
- HOTflow® Engine Heaters  
CTM, CKM, CSM Models

- PAGES 8 - 15
- Thermosiphon Engine Heaters  
Weathertight Design  
TPS, CB, CL, SB, SL, WL, OEM Replacement Models

- PAGES 16 - 17
- Thermosiphon Engine Heaters  
Hazardous Location  
EE Models

- 2** PAGES 20 - 25
- Lube Oil Heaters (AC and DC)
  - Industrial Immersion Heaters  
Thread-in and Threadless Models

- 3** PAGES 27 - 32
- Remote Thermostats for Lube Oil Heaters
  - Temperature Controls for Thermosiphon Engine Heaters
  - Complete Control Systems

- 4** PAGES 34 - 36
- Battery Warming Pads & Accessories
  - Blanket Style Battery Warmers - UL Recognized
  - Silicone Hot Pads

- 5** PAGES 38 - 49
- In-block Heaters
  - Electrical Cords for In-block Heaters
  - Thermocords and TwinStat™
  - Flush Mount Kits and Accessories

## SECTION 1

---



# HOTflow® Engine Heaters

## CTM Model Single Phase

1000–2500 Watts



Meets requirements for installation on any UL 2200 listed generator.

## Isolation Mounting Kit (optional)

CTM-IMK

HOTSTART's HOTflow® engine heater (CTM Model) features an integrated pump that combines the benefits of forced circulation with a compact design that can mount to a variety of small engine applications. Forced circulation of the coolant delivers uniform heating throughout the entire engine, extends element life and offers a significant reduction in electrical consumption.

Thermostat Range	
ON	OFF
100°F (38°C)	120°F (49°C)

Engine Displacement CID/Liter	Power Supply			kW	Amps	Model Number
	Volts	Ø	Hz			
<b>CTM w/8' (2.4 m) cord and NEMA plug*</b>						
0–500CID 0–8L	120	1	60	1	8.8	CTM10110-N00 CTM10210-N00
	240	1	50/60	1	4.4	
500–750CID 8–12L	120	1	60	1.5	13.0	CTM15110-N00 CTM15210-N00
	240	1	50/60	1.5	6.5	
750–1200CID 12–20L	120	1	60	2.5	21.3	CTM25110-N00 CTM25210-N00
	240	1	50/60	2.5	10.7	
<b>CTM w/9.8' (3 m) cord, without plug</b>						
0–500CID 0–8L	120	1	60	1	8.8	CTM10110-A00 CTM10210-A00
	240	1	50/60	1	4.4	
500–750CID 8–12L	120	1	60	1.5	13.0	CTM15110-A00 CTM15210-A00
	240	1	50/60	1.5	6.5	
750–1200CID 12–20L	120	1	60	2.5	21.3	CTM25110-A00 CTM25210-A00
	240	1	50/60	2.5	10.7	
<b>CTM w/6.6' (2 m) cord and Schuko plug (Euro)**</b>						
0–500CID 0–8L	240	1	50/60	1	4.4	CTM10210-E00
500–750CID 8–12L	240	1	50/60	1.5	6.5	CTM15210-E00
750–1200CID 12–20L	240	1	50/60	2.5	10.7	CTM25210-E00

\* - UL/C-US listed  
\*\* - CE compliant

Other voltages available. Consult the factory.

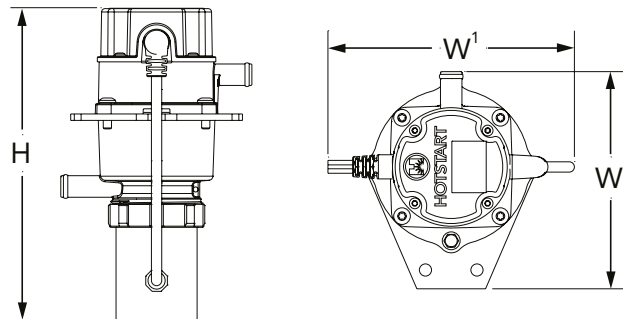

Height (H)	Width1 (W <sup>1</sup> )	Width2 (W <sup>2</sup> )	Weight
9.1" 230mm	7.0" 145mm	6.3" 161mm	3.5 lbs. 1.6 kg



Engine Displacement CID/Liter	Power Supply			kW	Amps	Model Number
	Volts	Ø	Hz			
1000–1500 CID 15–23 L	120	1	60	3	25.0	CKM1030160-000
	230	1	50	3	13.0	* CKM1030250-000
	240	1	60	3	13.0	CKM1030260-000
1500–2000 CID 23–30 L	230	1	50	4	13.0	* CKM1040250-000
	240	1	60	4	16.7	CKM1040260-000
2000 – 2500 CID 30–38 L	230	1	50	5	21.7	* CKM1050250-000
	240	1	60	5	20.8	CKM1050260-000
2500–3000 CID 38–50 L	230	1	50	6	26.1	* CKM1060250-000
	240	1	60	6	25.0	CKM1060260-000

\* CE compliant  
All other models – UL/C-US recognized

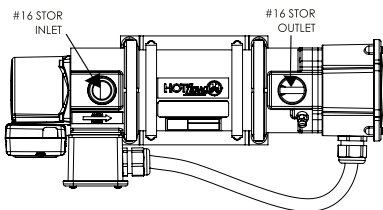
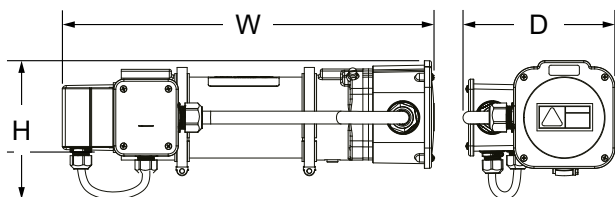

Height (H)	Width (W)	Depth (D)	Weight
6.9"	18.4"	8.5"	13.2 lbs.
175 mm	467 mm	216 mm	6.0 kg

#### ADAPTER FITTINGS (CKM MODELS ONLY)

For the use of 0.75" or 1" ID heater hose, hose barb adapters are available. See below.

HB-16STORX3/4HB	#16 STOR to 3/4" hosebarb adapter. Installs in #16 STOR female inlet or outlet of heater.
HB-16STORX1HB	#16 STOR to 1" hosebarb adapter. Installs in #16 STOR female inlet or outlet of heater.

## HOTflow® Engine Heaters

### CKM Model Single Phase

3000–6000 Watts



Meets requirements for installation on any UL 2200 listed generator.

HOTSTART's HOTflow® engine heater (CKM Model) is a thermostatically controlled heater with an integrated pump, built in bleed screw and a high-limit thermostat that can be manually reset. The CKM is designed for the technician in mind, allowing for easy access to all major components. Forced circulation of the coolant delivers uniform heating throughout the entire engine, extends element life and offers a significant reduction in electrical consumption.

Thermostat Range	
ON	OFF
100°F (38°C)	120°F (49°C)

# HOTflow® Engine Heaters

## CSM Model Single & Three Phase

3000–12000 Watts



Meets requirements for installation on any UL 2200 listed generator.

HOTSTART's HOTflow® engine heater (CSM Model) features a thermostat, pump and all required controls. Forced circulation of the coolant delivers uniform heating throughout the entire engine, extends element life and offers a significant reduction in electrical consumption.

The HOTflow® CSM operates automatically when provided contacts are supplied with a 24 V DC signal from the engine.

Thermostat Range	
ON	OFF
100°F (38°C)	120°F (49°C)

Engine Displacement CID/Liter	Power Supply			kW	Amps	Style	Model Number
	Volts	Ø	Hz				
1000–1500 CID 15–25L	120	1	60	3	26.3	A	CSM10301-000
	208	1	60	3	15.1	A	CSM10308-000
	208	3	60	3	8.7	B	CSM30308-000
	230	1	50	3	13.7	A	* CSM1030J-5A0
	240	1	60	3	13.1	A	CSM10302-000
	400	3	50	3	4.9	B	* CSM3030A-5A0
	480	1	60	3	7.0	B	CSM10304-000
	480	3	60	3	4.4	B	CSM30304-000
1500–3000 CID 25–50L	208	1	60	6	29.6	A	CSM10608-000
	208	3	60	6	17.1	B	CSM30608-000
	230	1	50	6	26.7	A	* CSM1060J-5A0
	240	1	60	6	25.6	A	CSM10602-000
	400	3	50	6	8.9	B	* CSM3060A-5A0
	440	3	60	6	8.1	B	* CSM3060F-5A1
	480	1	60	6	12.8	B	CSM10604-000
	480	3	60	6	7.4	B	CSM30604-000
575	3	60	6	6.2	B	CSM30605-000	
3000–4500 CID 50–75L	208	1	60	9	44.0	A	CSM10908-000
	208	3	60	9	25.4	B	CSM30908-000
	230	1	50	9	39.8	A	* CSM1090J-5A0
	240	1	60	9	38.1	A	CSM10902-000
	400	3	50	9	13.2	B	* CSM3090A-5A0
	440	3	60	9	12.2	B	* CSM3090F-5A1
	480	1	60	9	19.1	B	CSM10904-000
	480	3	60	9	11.0	B	CSM30904-000
575	3	60	9	9.2	B	CSM30905-000	
4500–6000 CID 75–100L	208	1	60	10.5	51.2	B	CSM11058-000
	208	3	60	12	33.7	B	CSM31208-000
	230	1	50	12	52.8	B	* CSM1120J-5A0
	240	1	60	12	50.6	B	CSM11202-000
	400	3	50	12	17.5	B	* CSM3120A-5A0
	440	3	60	12	15.9	B	* CSM3120F-5A2
	480	1	60	12	25.3	B	CSM11204-000
	480	3	60	12	14.6	B	CSM31204-000
575	3	60	12	12.2	B	CSM31205-000	

\* CE compliant/union pump configuration  
Other voltages available. Consult the factory.

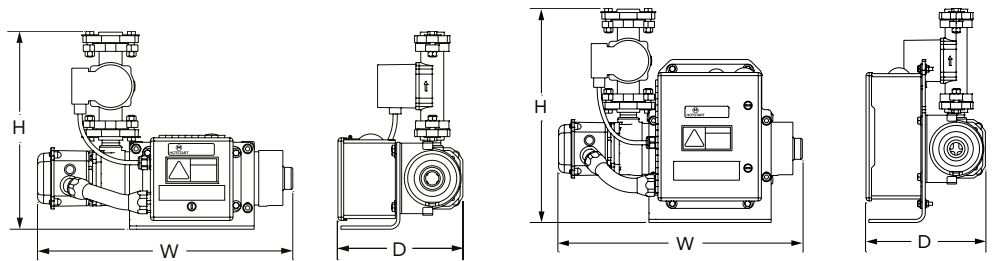

Height (H)	Width (W)	Depth (D)	Weight	Height (H)	Width (W)	Depth (D)	Weight
15.0"	19.4"	9.5"	37 lbs.	17.0"	19.4"	9.5"	54 lbs.
383 mm	493 mm	242 mm	16.8 kg	434 mm	493 mm	242 mm	24.5 kg

\* If a union pump is installed, the model's height (H) will decrease by approximately 1.5" (38mm)



# HOTflow® Technician Certification Training

HOTSTART's HOTflow® Technician Certification Training is an online webinar developed to train technicians in the field on how to install HOTflow® heaters to optimize engine preheating. Field technicians see heater applications everyday when servicing a generator. HOTSTART strives to provide the best tools and tips to these field experts to maximize the heater's performance in real world applications.

## WEBINAR TOPICS INCLUDE:

- Introduction of HOTflow® Heating Systems
- Safety and Preparation
- Heater Connections
- Heater Installation
- Plumbing
- Start-up and Commissioning the Heater
- Common Problems
- Best Practices

Go online to [www.hotstart.com](http://www.hotstart.com) to register or call Robert Fridye at 509-536-8660 to sign up today!

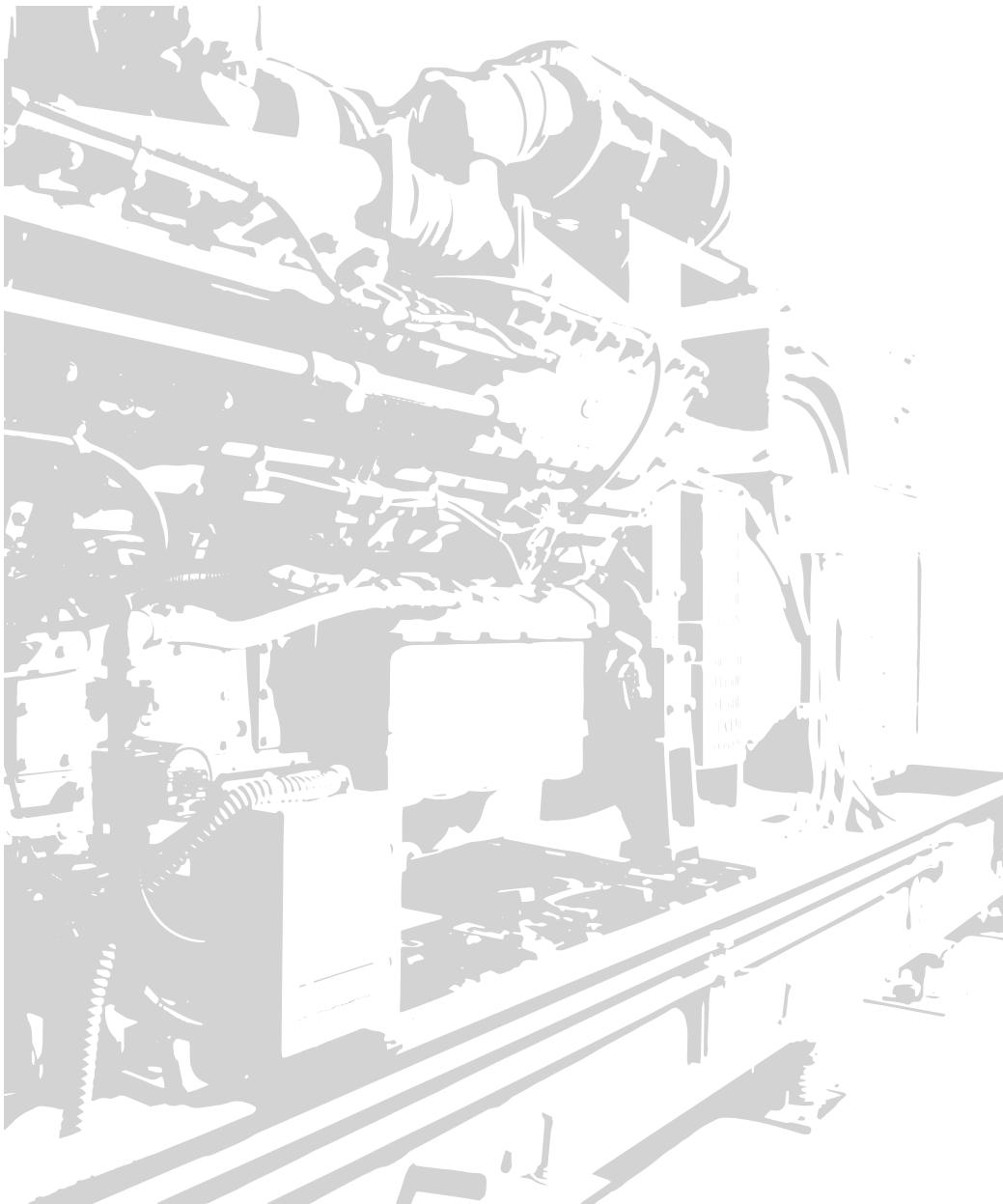

# Thermosiphon Engine Heaters

TPS Model Single Phase

500–2000 Watts



Temperature Range		Numerical Code
ON	OFF	
80°F (27°C)	100°F (38°C)	8
100°F (38°C)	120°F (49°C)	10
120°F (49°C)	140°F (60°C)	12

Engine Displacement	Watts	Model Number 120V	Amps	Model Number 240V	Amps	Model Number 277V	Amps
150 CID 2.5L	500	TPS051GT8-000	4.2	TPS052GT8-000	2.1	TPS057GT10-000	1.8
		TPS051GT10-000	4.2	TPS052GT10-000	2.1		
		TPS051GT12-000	4.2	TPS052GT10-013	2.1		
		—	—	TPS052GT12-000	2.1		
		—	—	—	—		
350 CID 5.7L	1000	TPS101GT8-000	8.4	TPS102GT8-000	4.2	TPS107GT10-000	3.6
		TPS101GT10-000	8.4	TPS102GT10-000	4.2		
		TPS101GT12-000	8.4	TPS102GT10-013	4.2		
		—	—	TPS102GT12-000	4.2		
350 – 500 CID 5.7 – 8.2L	1500	TPS151GT8-000	12.5	TPS152GT8-000	6.3	TPS157GT10-000	5.4
		TPS151GT10-000	12.5	TPS152GT10-000	6.3		
		TPS151GT12-000	12.5	TPS152GT10-013	6.3		
		—	—	TPS152GT12-000	6.3		
		—	—	—	—		
500 – 700 CID 8.2 – 11.5L	1800	TPS181GT8-000	15	—	—	—	—
	2000	TPS181GT10-000	15	TPS202GT8-000	8.3	TPS207GT10-000	7.2
		TPS181GT12-000	15				
—	—	—	—				
				TPS202GT10-013	8.3		
				TPS202GT12-000	8.3		

Power cord length on all models – 48" (1219mm)

TPS engine preheaters include a fixed setting thermostat. A single or double digit numeral at the end of the model number prefix designates the temperature range. **Example:** TPS101GT10-000 (see chart in left column)

-013 Engine preheater features 2 meter round cord and Schuko plug - CE compliant

## Replacement Parts

For TPS Models

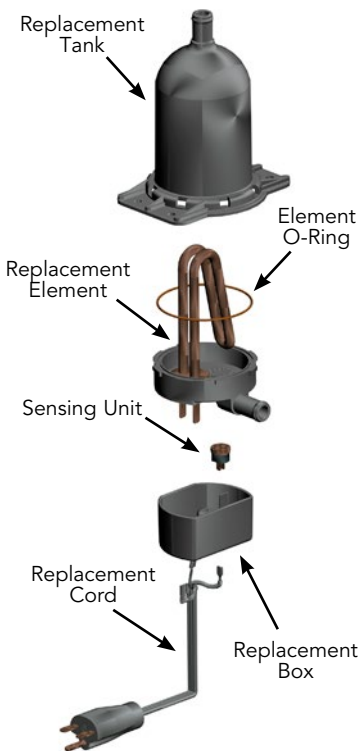

Model Number	Replacement Parts					
	Sensing Unit	Element	Tank	Box	Power Cord	Element O-ring
TPS051GT8-000	LSU-8	REPS051T8	TPS-T	CPS-1	11P48UU	TPS-BOR
TPS051GT10-000	LSU-10	REPS051T10	TPS-T	CPS-1	11P48UU	TPS-BOR
TPS051GT12-000	LSU-12	REPS051T12	TPS-T	CPS-1	11P48UU	TPS-BOR
TPS052GT8-000	LSU-8	REPS052T8	TPS-T	CPS-1	21P48UU	TPS-BOR
TPS052GT10-000	LSU-10	REPS052T10	TPS-T	CPS-1	21P48UU	TPS-BOR
TPS052GT10-013	LSU-10	REPS052T10	TPS-T	CPS-2	21SCH81UU	TPS-BOR
TPS052GT12-000	LSU-12	REPS052T12	TPS-T	CPS-1	21P48UU	TPS-BOR
TPS057GT10-000	LSU-10	REPS057T10	TPS-T	CPS-1	16H48UU	TPS-BOR
TPS101GT8-000	LSU-8	REPS101T8	TPS-T	CPS-1	11P48UU	TPS-BOR
TPS101GT10-000	LSU-10	REPS101T10	TPS-T	CPS-1	11P48UU	TPS-BOR
TPS101GT12-000	LSU-12	REPS101T12	TPS-T	CPS-1	11P48UU	TPS-BOR
TPS102GT8-000	LSU-8	REPS102T8	TPS-T	CPS-1	21P48UU	TPS-BOR
TPS102GT10-000	LSU-10	REPS102T10	TPS-T	CPS-1	21P48UU	TPS-BOR
TPS102GT10-013	LSU-10	REPS102T10	TPS-T	CPS-2	21SCH81UU	TPS-BOR
TPS102GT12-000	LSU-12	REPS102T12	TPS-T	CPS-1	21P48UU	TPS-BOR
TPS107GT10-000	LSU-10	REPS107T10	TPS-T	CPS-1	16H48UU	TPS-BOR
TPS151GT8-000	LSU-8	REPS151T8	TPS-T	CPS-1	11P48UU	TPS-BOR
TPS151GT10-000	LSU-10	REPS151T10	TPS-T	CPS-1	11P48UU	TPS-BOR
TPS151GT12-000	LSU-12	REPS151T12	TPS-T	CPS-1	11P48UU	TPS-BOR
TPS152GT8-000	LSU-8	REPS152T8	TPS-T	CPS-1	21P48UU	TPS-BOR
TPS152GT10-000	LSU-10	REPS152T10	TPS-T	CPS-1	21P48UU	TPS-BOR
TPS152GT10-013	LSU-10	REPS152T10	TPS-T	CPS-2	21SCH81UU	TPS-BOR
TPS152GT12-000	LSU-12	REPS152T12	TPS-T	CPS-1	21P48UU	TPS-BOR
TPS157GT10-000	LSU-10	REPS157T10	TPS-T	CPS-1	16H48UU	TPS-BOR
TPS181GT8-000	LSU-8	REPS181T8	TPS-T	CPS-1	12P16H48UU	TPS-BOR
TPS181GT10-000	LSU-10	REPS181T10	TPS-T	CPS-1	12P16H48UU	TPS-BOR
TPS181GT12-000	LSU-12	REPS181T12	TPS-T	CPS-1	12P16H48UU	TPS-BOR
TPS202GT8-000	LSU-8	REPS202T8	TPS-T	CPS-1	21P48UU	TPS-BOR
TPS202GT10-000	LSU-10	REPS202T10	TPS-T	CPS-1	21P48UU	TPS-BOR
TPS202GT10-013	LSU-10	REPS202T10	TPS-T	CPS-2	21SCH81UU	TPS-BOR
TPS202GT12-000	LSU-12	REPS202T12	TPS-T	CPS-1	21P48UU	TPS-BOR
TPS207GT10-000	LSU-10	REPS207T10	TPS-T	CPS-1	16H48UU	TPS-BOR



Engine Displacement	Model Number	Volts	Watts	Phase	Amps	Thermostat Range	
						On	Off
150CID 2.5L	TPS051GT12-001	120	500	1	4.2	100°F (38°C)	120°F (49°C)
	TPS051GT12-A00	120	500	1	4.2	ADJUSTABLE	
	TPS052GT12-001	240	500	1	2.1	100°F (38°C)	120°F (49°C)
	TPS052GT12-A00	240	500	1	2.1	ADJUSTABLE	
350CID 5.7L	TPS101GT12-001	120	1000	1	8.4	100°F (38°C)	120°F (49°C)
	TPS101GT12-A00	120	1000	1	8.4	ADJUSTABLE	
	TPS102GT12-001	240	1000	1	4.2	100°F (38°C)	120°F (49°C)
	TPS102GT12-A00	240	1000	1	4.2	ADJUSTABLE	
350 – 500CID 5.7 – 8.2L	TPS151GT12-001	120	1500	1	12.5	100°F (38°C)	120°F (49°C)
	TPS151GT12-A00	120	1500	1	12.5	ADJUSTABLE	
	TPS152GT12-001	240	1500	1	6.3	100°F (38°C)	120°F (49°C)
	TPS152GT12-A00	240	1500	1	6.3	ADJUSTABLE	
500 – 700CID 8.2 – 11.5L	TPS181GT12-001	120	1800	1	15	100°F (38°C)	120°F (49°C)
	TPS181GT12-A00	120	1800	1	15	ADJUSTABLE	
	TPS202GT12-001	240	2000	1	8.3	100°F (38°C)	120°F (49°C)
	TPS202GT12-A00	240	2000	1	8.3	ADJUSTABLE	

-001 Remote thread-in fixed temperature thermostat

Adjustable 90° – 130°F (32° – 54°C)  
On differential -20°F (-7°C)

### In-line thermostat options:

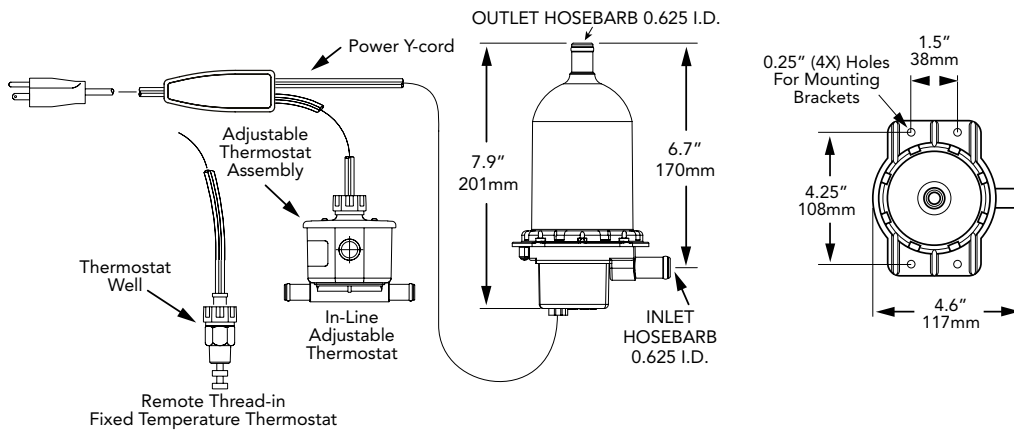

Model Number	Volts	Watts	Replacement Parts			
			Sensing Unit	Element	Power Y-cord	Thermostat Well
TPS051GT12-001	120	500	LSU-10	REPS051T12	TPS-YC1	TW2374-1
TPS051GT12-A00	120	500	RSU90-130	REPS051T12	#	#
TPS052GT12-001	240	500	LSU-10	REPS052T12	TPS-YC2	TW2374-1
TPS052GT12-A00	240	500	RSU90-130	REPS052T12	#	#
TPS101GT12-001	120	1000	LSU-10	REPS101T12	TPS-YC1	TW2374-1
TPS101GT12-A00	120	1000	RSU90-130	REPS101T12	#	#
TPS102GT12-001	240	1000	LSU-10	REPS102T12	TPS-YC2	TW2374-1
TPS102GT12-A00	240	1000	RSU90-130	REPS102T12	#	#
TPS151GT12-001	120	1500	LSU-10	REPS151T12	TPS-YC1	TW2374-1
TPS151GT12-A00	120	1500	RSU90-130	REPS151T12	#	#
TPS152GT12-001	240	1500	LSU-10	REPS152T12	TPS-YC2	TW2374-1
TPS152GT12-A00	240	1500	RSU90-130	REPS152T12	#	#
TPS181GT12-001	120	1800	LSU-10	REPS181T12	12P16H54S54X10UU	TW2374-1
TPS181GT12-A00	120	1800	RSU90-130	REPS181T12	#	#
TPS202GT12-001	240	2000	LSU-10	REPS202T12	TPS-YC2	TW2374-1
TPS202GT12-A00	240	2000	RSU90-130	REPS202T12	#	#

-001 Remote thread-in fixed temperature thermostat

# Call Factory

## Thermosiphon Engine Heaters

TPS Model w/in-line adjustable and remote thread-in fixed thermostat.

Single Phase

500–2000 Watts



Remote Adjustable Thermostat Assembly

Part Number | TFTA-5/8HB

## Replacement Parts

For TPS Model w/in-line adjustable and remote thread-in fixed thermostat.

Single Phase

Common replacement parts for all TPS engine preheaters:

- Tank
- Box
- Element O-ring

See table on page 8

# Thermosiphon Engine Heaters

## CB Model Weathertight Single Phase

1500-2500 Watts



CB Model without thermostat



CB Model with thermostat

Engine Displacement	Model Number without Thermostat	Model Number with Thermostat see chart 1	Volts	Watts	Phase	Amps
350 – 500 CID 5.7 – 8.2 L	CB115100-000	CB1151XX-200	120	1500	1	12.5
	CB115800-000	CB1158XX-200	208	1500	1	7.2
	CB115200-000	CB1152XX-200	240	1500	1	6.3
	CB115700-000	CB1157XX-200	277	1500	1	5.4
	CB115300-000	CB1153XX-200	380	1500	1	3.9
	CB115400-000	CB1154XX-200	480	1500	1	3.1
500 – 600 CID 8.2 – 9.8 L	CB120100-000	CB1201XX-200	120	2000	1	16.7
	CB120800-000	CB1208XX-200	208	2000	1	9.6
	CB120200-000	CB1202XX-200	240	2000	1	8.3
	CB120300-000	CB1203XX-200	380	2000	1	5.3
	CB120400-000	CB1204XX-200	480	2000	1	4.2
600 – 800 CID 9.8 – 13.1 L	CB125100-000	CB1251XX-200	120	2500	1	20.8
	CB125800-000	CB1258XX-200	208	2500	1	12.0
	CB125200-000	CB1252XX-200	240	2500	1	10.4
	CB125700-000	CB1257XX-200	277	2500	1	9.0
	CB125300-000	CB1253XX-200	380	2500	1	6.6
	CB125400-000	CB1254XX-200	480	2500	1	5.2

### CB Model

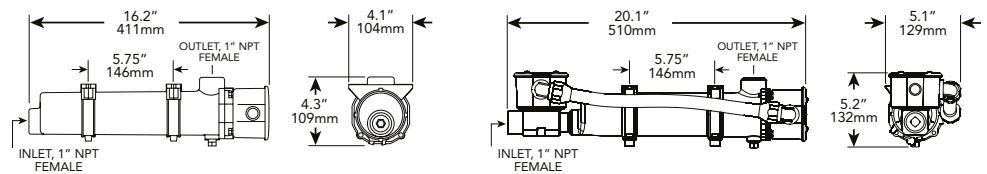

## CL Model Weathertight Single Phase

3000-5000 Watts



CL Model without thermostat



CL Model with thermostat

Engine Displacement	Model Number without Thermostat	Model Number with Thermostat see chart 1	Volts	Watts	Phase	Amps
800 – 1000 CID 13.1 – 16.4 L	CL130100-100	CL1301XX-200	120	3000	1	25.0
	CL130800-100	CL1308XX-200	208	3000	1	14.4
	CL130200-100	CL1302XX-200	240	3000	1	12.5
	CL130700-100	CL1307XX-200	277	3000	1	10.8
	CL130300-100	CL1303XX-200	380	3000	1	7.9
	CL130400-100	CL1304XX-200	480	3000	1	6.3
1000 – 1350 CID 16.4 – 22.1 L	CL140800-100	CL1408XX-200	208	4000	1	19.2
	CL140200-100	CL1402XX-200	240	4000	1	16.7
	CL140700-100	CL1407XX-200	277	4000	1	14.4
	CL140300-100	CL1403XX-200	380	4000	1	10.5
1350 – 1650 CID 22.1 – 27.0 L	CL150800-100	CL1508XX-200	208	5000	1	24.0
	CL150200-100	CL1502XX-200	240	5000	1	20.8
	CL150700-100	CL1507XX-200	277	5000	1	18.1
	CL150300-100	CL1503XX-200	380	5000	1	13.2
CL150400-100	CL1504XX-200	480	5000	1	10.4	

### CL Model

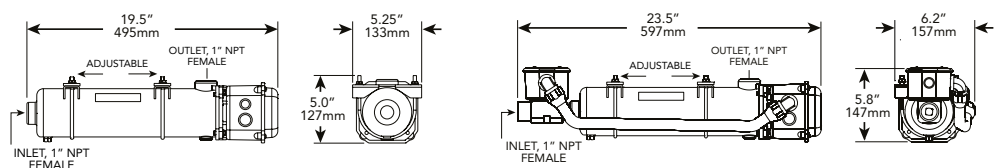

### CHART 1

#### Heaters with Thermostats

To specify temperature range of thermostat, insert numerical code from chart in place of the **XX** in model number.

#### Example:

Desired Temp. Range: 100° – 120°F  
Model Number: CB1151**XX**-200  
Order as: CB1151**10**-200

Temperature Range		Numerical Code
ON	OFF	
80°F (27°C)	100°F (38°C)	08
100°F (38°C)	120°F (49°C)	10
120°F (49°C)	140°F (60°C)	12
Adjustable 90° – 130°F (32° – 54°C)		A3

# Replacement Parts

For thermosiphon engine heaters CB/CL Models

## CHART 2

### Heaters with Thermostats

Temperature Range		Sensing Unit
ON	OFF	
80°F (27°C)	100°F (38°C)	FSU8
100°F (38°C)	120°F (49°C)	FSU10
120°F (49°C)	140°F (60°C)	FSU12
Adjustable 90° – 130°F (32° – 54°C)		FSU90-130

### Example:

Model Number: CB115110-200  
T-Stat Replacement: FSU10

## ADAPTER FITTINGS

For the use of 0.75" or 1" ID heater hose, hose barb adapters are available. See below.

HB-1	1" NPT to 1" hose barb adapter. Installs in 1" NPT female inlet or outlet of the heater.
HB-3/4	1" NPT to 0.75" hose barb adapter. Installs in 1" NPT female inlet or outlet of the heater.

Model Number without Thermostat	Model Number with Thermostat see chart 2	Element Replacement
CB115100-000 CB115800-000 CB115200-000 CB115700-000 CB115300-000 CB115400-000	CB1151XX-200 CB1158XX-200 CB1152XX-200 CB1157XX-200 CB1153XX-200 CB1154XX-200	RECB1151 RECB1158 RECB1152 RECB1157 RECB1153 RECB1154
CB120100-000 CB120800-000 CB120200-000 CB120300-000 CB120400-000	CB1201XX-200 CB1208XX-200 CB1202XX-200 CB1203XX-200 CB1204XX-200	RECB1201 RECB1208 RECB1202 RECB1203 RECB1204
CB125100-000 CB125800-000 CB125200-000 CB125700-000 CB125300-000 CB125400-000	CB1251XX-200 CB1258XX-200 CB1252XX-200 CB1257XX-200 CB1253XX-200 CB1254XX-200	RECB1251 RECB1258 RECB1252 RECB1257 RECB1253 RECB1254

Common Replacement Parts available for all listed heaters	
High Limit Control	HLC-165
Check Valve	RV-M
Element O-ring	TMM-OR
Tank	RTB
Box	RTBCB
Mounting Brackets	RTMMB

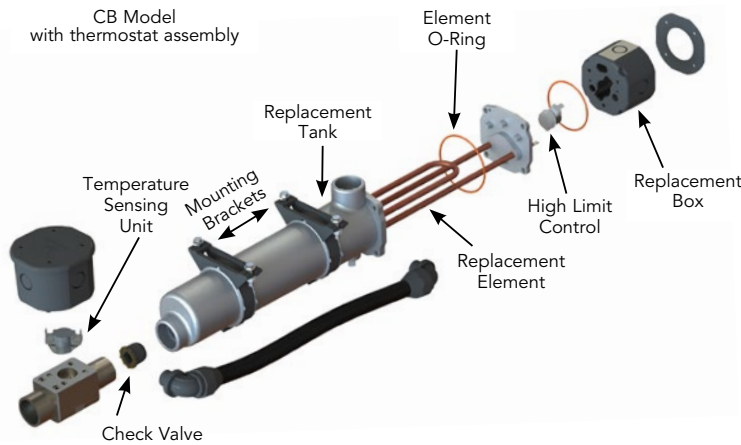

Model Number without Thermostat	Model Number with Thermostat see chart 2	Element Replacement
CL130100-100 CL130800-100 CL130200-100 CL130700-100 CL130300-100 CL130400-100	CL1301XX-200 CL1308XX-200 CL1302XX-200 CL1307XX-200 CL1303XX-200 CL1304XX-200	RECL1301-100 RECL1308-100 RECL1302-100 RECL1307-100 RECL1303-100 RECL1304-100
CL140800-100 CL140200-100 CL140700-100 CL140300-100 CL140400-100	CL1408XX-200 CL1402XX-200 CL1407XX-200 CL1403XX-200 CL1404XX-200	RECL1408-100 RECL1402-100 RECL1407-100 RECL1403-100 RECL1404-100
CL150800-100 CL150200-100 CL150700-100 CL150300-100 CL150400-100	CL1508XX-200 CL1502XX-200 CL1507XX-200 CL1503XX-200 CL1504XX-200	RECL1508-100 RECL1502-100 RECL1507-100 RECL1503-100 RECL1504-100

Common Replacement Parts available for all listed heaters	
High Limit Control	HLC-165
Check Valve	RV-M
Element O-ring	TML-OR
Tank	RTL
Box	RTBCL-100
Mounting Brackets	FK7

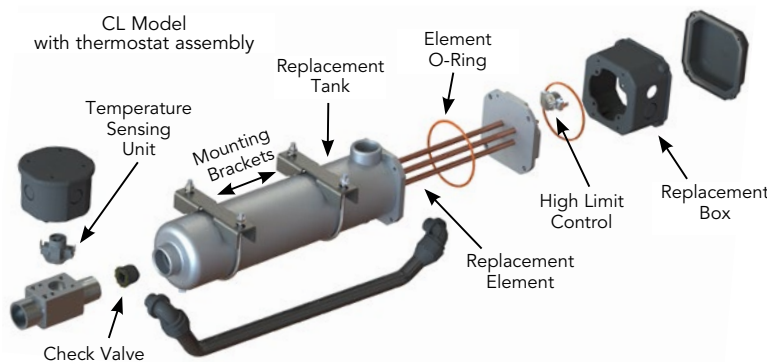

# Thermosiphon Engine Heaters

SB Model  
with power cord  
Weathertight  
Single Phase

1500–2500 Watts



SB Model with power cord no thermostat



SB Model with thermostat and power cord

SL Model  
with power cord  
Weathertight  
Single Phase

3000–4000 Watts



SL Model with power cord no thermostat



SL Model with thermostat and power cord

Engine Displacement	Model Number without Thermostat	Model Number with Thermostat see chart 1	Volts	Watts	Phase	Amps
350 – 500 CID 5.7 – 8.2L	SB115100-000	SB1151XX-200	120	1500	1	12.5
	SB115800-000	SB1158XX-200	208	1500	1	7.2
	SB115200-000	SB1152XX-200	240	1500	1	6.3
	SB115700-000	SB1157XX-200	277	1500	1	5.4
500 – 600 CID 8.2 – 9.8L	SB120100-000	SB1201XX-200	120	2000	1	16.7
	SB120800-000	SB1208XX-200	208	2000	1	9.6
	SB120200-000	SB1202XX-200	240	2000	1	8.3
600 – 800 CID 9.8 – 13.1 L	SB122100-000	SB1221XX-200	120	2250	1	18.8
	SB125800-000	SB1258XX-200	208	2500	1	12.0
	SB125200-000	SB1252XX-200	240	2500	1	10.4
	SB125700-000	SB1257XX-200	277	2500	1	9.0

Power cord length on all models – 72" (1829 mm)  
All 208 V and 277 V models come with cord only - no plug.

## SB Model

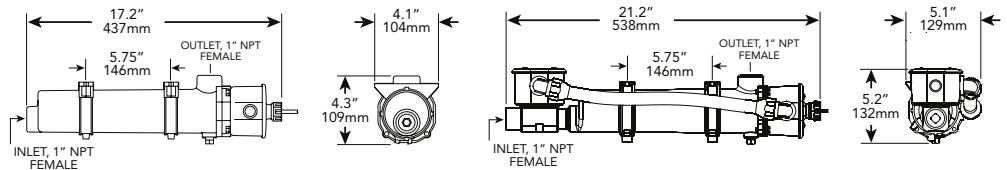

Engine Displacement	Model Number without Thermostat	Model Number with Thermostat see chart 1	Volts	Watts	Phase	Amps
800 – 1000 CID 13.1 – 16.4 L	SL130800-100	SL1308XX-200	208	3000	1	14.4
	SL130200-100	SL1302XX-200	240	3000	1	12.5
	SL130700-100	SL1307XX-200	277	3000	1	10.8
1000 – 1350 CID 16.4 – 22.1 L	SL140800-100	SL1408XX-200	208	4000	1	19.2
	SL140200-100	SL1402XX-200	240	4000	1	16.7
	SL140700-100	SL1407XX-200	277	4000	1	14.4

Power cord length on all models – 72" (1829mm)  
All 208 V and 277 V models come with cord only - no plug.

## SL Model

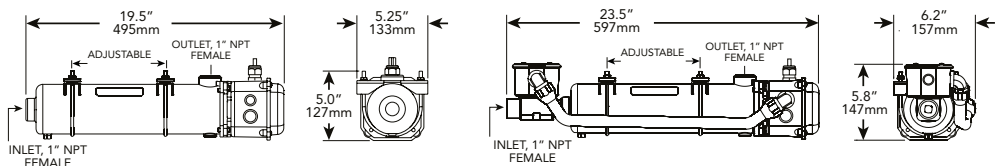

## CHART 1

### Heaters with Thermostats

To specify temperature range of thermostat, insert numerical code from chart in place of the **XX** in model number.

#### Example:

Desired Temp. Range: 100° – 120°F  
Model Number: SB1151**XX**-200  
Order as: SB1151**10**-200

Temperature Range		Numerical Code
ON	OFF	
80°F (27°C)	100°F (38°C)	08
100°F (38°C)	120°F (49°C)	10
120°F (49°C)	140°F (60°C)	12
Adjustable 90° – 130°F (32° – 54°C)		A3

# Replacement Parts

For thermosiphon engine heaters SB/SL Models

## CHART 2

### Heaters with Thermostats

Temperature Range		Sensing Unit
ON	OFF	
80°F (27°C)	100°F (38°C)	FSU8
100°F (38°C)	120°F (49°C)	FSU10
120°F (49°C)	140°F (60°C)	FSU12
Adjustable 90° - 130°F (32° - 54°C)		FSU90-130

### Example:

Model Number: SB115110-200  
T-Stat Replacement: FSU10

## ADAPTER FITTINGS

For the use of 0.75" or 1" ID heater hose, hose barb adapters are available. See below.

HB-1	1" NPT to 1" hose barb adapter. Installs in 1" NPT female inlet or outlet of the heater.
HB-3/4	1" NPT to 0.75" hose barb adapter. Installs in 1" NPT female inlet or outlet of the heater.

Model Number without Thermostat	Model Number with Thermostat see chart 2	Element Replacement	Power Cord
SB115100-000	SB1151XX-200	RESB1151	RHB-1-15
SB115800-000	SB1158XX-200	RESB1158	RHB-WOP
SB115200-000	SB1152XX-200	RESB1152	RHB-2-15
SB115700-000	SB1157XX-200	RESB1157	RHB-WOP
SB120100-000	SB1201XX-200	RESB1201	RHB-1-20
SB120800-000	SB1208XX-200	RESB1208	RHB-WOP
SB120200-000	SB1202XX-200	RESB1202	RHB-2-15
SB122100-000	SB1221XX-200	RESB1221	RHB-1-20
SB125800-000	SB1258XX-200	RESB1258	RHB-WOP
SB125200-000	SB1252XX-200	RESB1252	RHB-2-15
SB125700-000	SB1257XX-200	RESB1257	RHB-WOP

Common Replacement Parts available for all listed heaters	
High Limit Control	HLC-165
Check Valve	RV-M
Element O-ring	TMM-OR
Tank	RTB
Box	RTBSB
Mounting Brackets	RTMMB

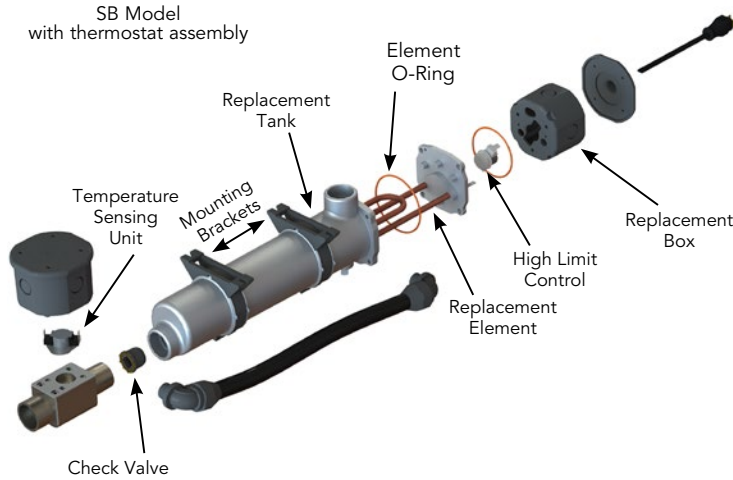

Model Number without Thermostat	Model Number with Thermostat see chart 2	Element Replacement	Power Cord
SL130800-100	SL1308XX-200	RESL1308-100	RHL-WOP
SL130200-100	SL1302XX-200	RESL1302-100	RHL-2-15
SL130700-100	SL1307XX-200	RESL1307-100	RHL-WOP
SL140800-100	SL1408XX-200	RESL1408-100	RHL-WOP
SL140200-100	SL1402XX-200	RESL1402-100	RHL-2-20
SL140700-100	SL1407XX-200	RESL1407-100	RHL-WOP

Common Replacement Parts available for all listed heaters	
High Limit Control	HLC-165
Check Valve	RV-M
Element O-ring	TML-OR
Tank	RTL
Box	RTBCL-100
Mounting Brackets	FK7

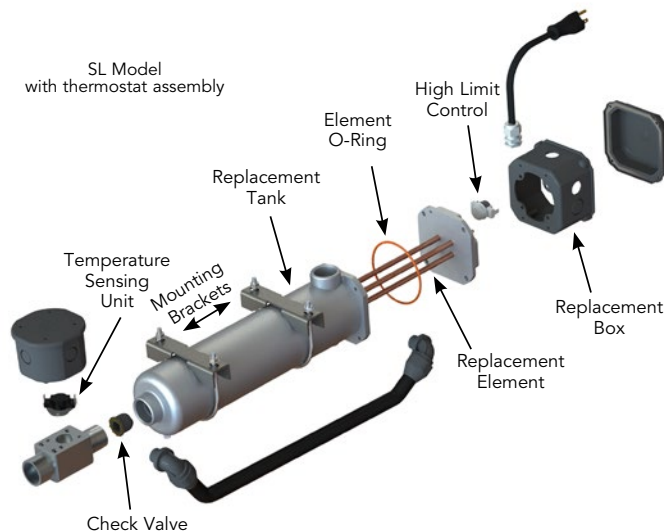



# Thermosiphon Engine Heaters

WL Series  
Weathertight  
Three Phase

2500-5000 Watts



WL Model without thermostat



WL Model with thermostat

## CHART 1

### Heaters with Thermostats

To specify temperature range of thermostat, insert numerical code from chart in place of the **XX** in model number.

#### Example:

Desired Temp. Range: 100° - 120°F  
Model Number: WL3252**XX**-200  
Order as: WL3252**10**-200

Temperature Range		Numerical Code
ON	OFF	
80°F (27C)	100°F (38C)	08
100°F (38C)	120°F (49C)	10
120°F (49C)	140°F (60C)	12
Adjustable 90° - 130°F (32° - 54°C)		A3

## CHART 2

### Heaters with Thermostats

Temperature Range		Sensing Unit
ON	OFF	
80°F (27°C)	100°F (38°C)	FSU8
100°F (38°C)	120°F (49°C)	FSU10
120°F (49°C)	140°F (60°C)	FSU12
Adjustable 90° - 130°F (32° - 54°C)		FSU90-130

#### Example:

Model Number: WL3252**10**-200  
T-Stat Replacement: FSU10

Engine Displacement	Model Number without Thermostat	Model Number with Thermostat see chart 1	Volts	Watts	Phase	Amps
600 - 800 CID 9.8 - 13.1 L	WL325800-000	WL3258XX-200	208	2500	3	6.9
	WL325200-000	WL3252XX-200	240	2500	3	6.0
	WL325A00-000	WL325AXX-200	400	2500	3	3.6
	WL325400-000	WL3254XX-200	480	2500	3	3.0
	WL325500-000	WL3255XX-200	575	2500	3	2.5
1000 - 1350 CID 16.4 - 22.1 L	WL340800-000	WL3408XX-200	208	4000	3	11.1
	WL340200-000	WL3402XX-200	240	4000	3	9.6
	WL340A00-000	WL340AXX-200	400	4000	3	5.8
	WL340400-000	WL3404XX-200	480	4000	3	4.8
	WL340500-000	WL3405XX-200	575	4000	3	4.0
1350 - 1650 CID 22.1 - 27.0 L	WL350800-000	WL3508XX-200	208	5000	3	13.9
	WL350200-000	WL3502XX-200	240	5000	3	12.0
	WL350A00-000	WL350AXX-200	400	5000	3	7.2
	WL350400-000	WL3504XX-200	480	5000	3	6.0
	WL350500-000	WL3505XX-200	575	5000	3	5.0

All 3 phase heaters with thermostat must use a control box.  
See Control Systems page 30.

## WL Model

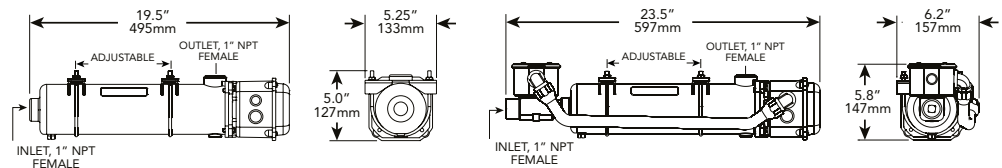

## Replacement Parts

Model Number without Thermostat	Model Number with Thermostat see chart 2	Element Replacement
WL325800-000	WL3258XX-200	REWL3258
WL325200-000	WL3252XX-200	REWL3252
WL325A00-000	WL325AXX-200	REWL325A
WL325400-000	WL3254XX-200	REWL3254
WL325500-000	WL3255XX-200	REWL3255
WL340800-000	WL3408XX-200	REWL3408
WL340200-000	WL3402XX-200	REWL3402
WL340A00-000	WL340AXX-200	REWL340A
WL340400-000	WL3404XX-200	REWL3404
WL340500-000	WL3405XX-200	REWL3405
WL350800-000	WL3508XX-200	REWL3508
WL350200-000	WL3502XX-200	REWL3502
WL350A00-000	WL350AXX-200	REWL350A
WL350400-000	WL3504XX-200	REWL3504
WL350500-000	WL3505XX-200	REWL3505

Common Replacement Parts available for all listed heaters	
High Limit Control	HLC-165
Check Valve	RV-M
Element O-ring	TML-OR
Tank	RTL
Mounting Brackets	FK7

### ADAPTER FITTINGS

For the use of 0.75" or 1" ID heater hose, hose barb adapters are available. See below.

HB-1	1" NPT to 1" hose barb adapter. Installs in 1" NPT female inlet or outlet of the heater.
HB-3/4	1" NPT to 0.75" hose barb adapter. Installs in 1" NPT female inlet or outlet of the heater.

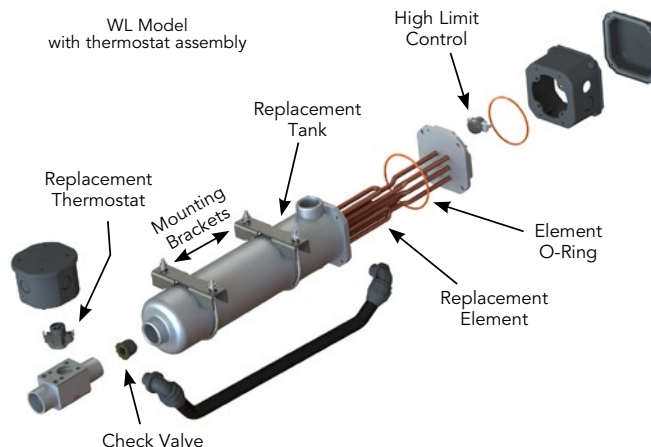



HOTSTART Model Number	Caterpillar Model Number	Volts	Pre-Wired at assembly	Watts	Phase	Amps
CL130DA2-000	7E-6247	120/240	120	3000	1	25.0 @ 120 V 12.5 @ 240 V
CL140EA2-000	—	240/480	240	4000	1	16.7 @ 240 V 8.3 @ 480 V
CL160EA2-000	7E-6248 (2006504)	240/480	240	6000	1	25.0 @ 240 V 12.5 @ 480 V
CL160CA2-000	7E-6249	120	2-120 V circuits	6000	1	25.0 per circuit

**NOTE:** Vertical installation ONLY

**For original equipment replacement:**

- Two 5" stainless steel clamps are included to mount heater to existing bracket.

**For new installations:**

- U-bolt mounting brackets available. Order kit number: **FK9**

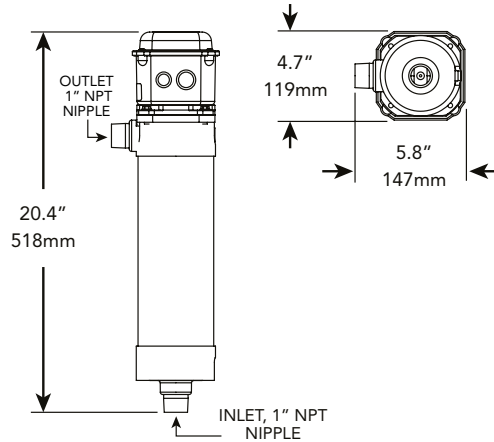

## Thermosiphon Engine Heaters

OEM Replacement  
Weathertight  
Single Phase

3000–6000 Watts



Vertical Mount  
OEM replacement

## Replacement Parts

HOTSTART Model Number	Element Replacement
CL130DA2-000	RECL130D
CL140EA2-000	RECL140E
CL160EA2-000	RECL160E
CL160CA2-000	RECL160C

Common Replacement Parts available for all OEM replacement heaters	
Thermostat	AMT70210-A2
Element O-ring	TML-OR
Tank	RTCSM
Box	RTBCL-100

### CL OEM Replacement

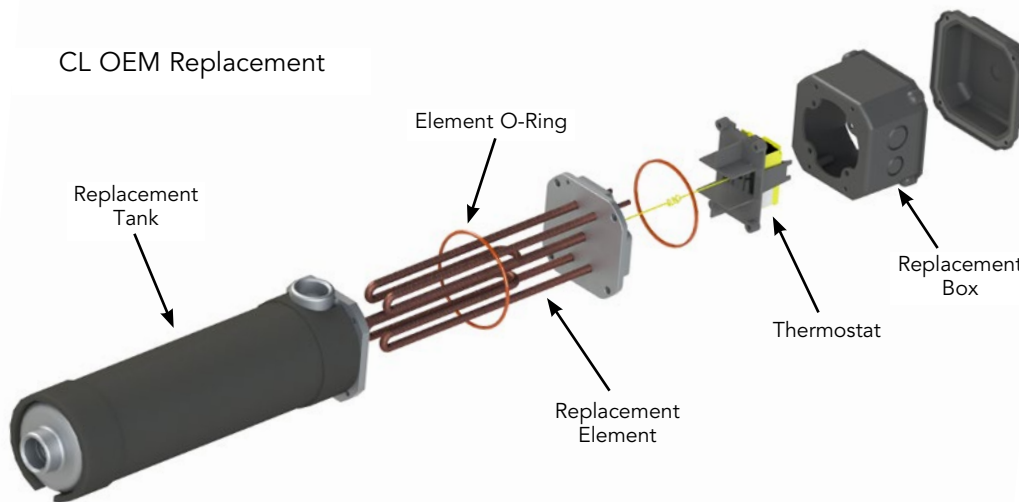

# Thermosiphon Engine Heaters

EE Model  
Hazardous Location  
Single Phase

1500-5000 Watts



EE Model without thermostat



EE Model with thermostat

### Heaters with Thermostats

EE Models are only available with a fixed setting temperature sensor.

Temperature Range		Numerical Code
ON	OFF	
100°F (38C)	120°F (49C)	10

All heaters over 480 V with a thermostat must use a control box. See Control Systems page 30.

### EE Replacement Thermostats

Example:

Model Number: EE130210-000  
T-Stat Replacement: RSU10

Temperature Range		Sensing Unit
ON	OFF	
100°F (38C)	120°F (49C)	RSU10

### ADAPTER FITTINGS

For the use of 0.75" or 1" ID heater hose, hose barb adapters are available. See below.

HB-1	1" NPT to 1" hose barb adapter. Installs in 1" NPT female inlet or outlet of the heater.
HB-3/4	1" NPT to 0.75" hose barb adapter. Installs in 1" NPT female inlet or outlet of the heater.

Engine Displacement	Model Number without Thermostat	Model Number with Thermostat	Volts	Watts	Phase	Amp
500 CID or less	EE115100-000	EE115110-000	120	1500	1	12.5
	EE115800-000	EE115810-000	208	1500	1	7.2
	EE115200-000	EE115210-000	240	1500	1	6.3
500 - 600 CID	EE120100-000	EE120110-000	120	2000	1	16.7
	EE120800-000	EE120810-000	208	2000	1	9.6
	EE120200-000	EE120210-000	240	2000	1	8.3
600 - 800 CID	EE125800-000	EE125810-000	208	2500	1	12.0
	EE125200-000	EE125210-000	240	2500	1	10.4
	EE125400-000	EE125410-000	480	2500	1	5.2
800 - 1000 CID	EE130800-000	EE130810-000	208	3000	1	14.4
	EE130200-000	EE130210-000	240	3000	1	12.5
	EE130400-000	EE130410-000	480	3000	1	6.3
1000 - 1350 CID	EE140800-000	EE140810-000	208	4000	1	19.2
	EE140200-000	EE140210-000	240	4000	1	16.7
	EE140400-000	EE140410-000	480	4000	1	8.3
1350 - 1650 CID	EE150400-000	EE150410-000	480	5000	1	10.4

### EE Model

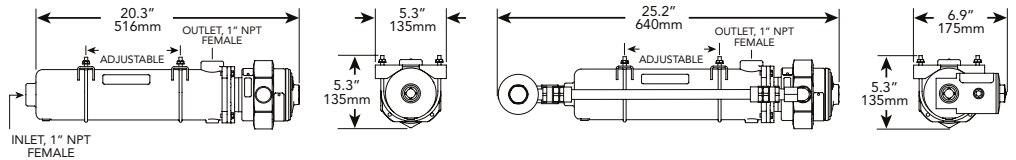

### Replacement Parts

Model Number without Thermostat	Model Number with Thermostat	Element Replacement
EE115100-000	EE115110-000	REEE1151
EE115800-000	EE115810-000	REEE1158
EE115200-000	EE115210-000	REEE1152
EE115400-000	EE115410-000	E01541E-50NA-00
EE120100-000	EE120110-000	REEE1201
EE120800-000	EE120810-000	REEE1208
EE120200-000	EE120210-000	REEE1202
EE120400-000	EE120410-000	E02041E-50NA-00
EE125800-000	EE125810-000	REEE1258
EE125200-000	EE125210-000	REEE1252
EE125400-000	EE125410-000	E02541E-CONA-00
EE130800-000	EE130810-000	REEE1308
EE130200-000	EE130210-000	REEE1302
EE130400-000	EE130410-000	E03041E-50NA-00
EE140800-000	EE140810-000	REEE1408
EE140200-000	EE140210-000	REEE1402
EE140400-000	EE140410-000	E04041E-50NA-00
EE150400-000	EE150410-000	E05041E-CONA-00

### Common Replacement Parts available for all listed heaters

Check Valve	RV-M
Flange	RF-L
Flange O-ring	TML-OR
Tank	RTL
MC-HL cable	PRP104301-029
Mounting Brackets	FK7

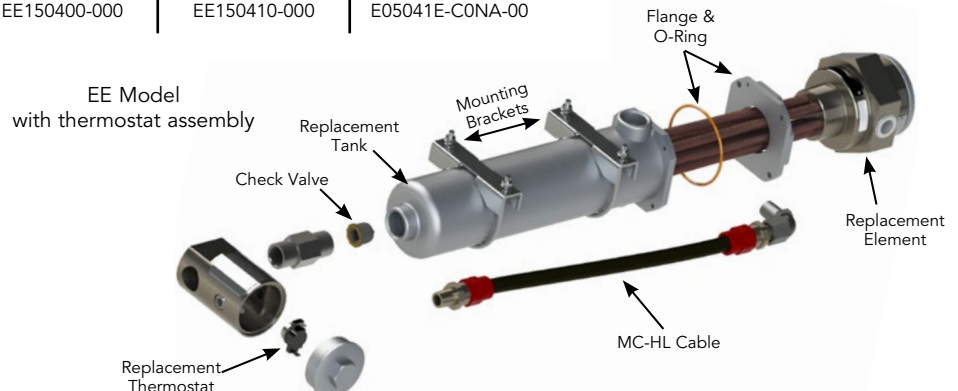

# Thermosiphon Engine Heaters

## EE Model Hazardous Location Three Phase

1500-5000 Watts



EE Model without thermostat



EE Model with thermostat

### Heaters with Thermostats

EE Models are only available with a fixed setting temperature sensor.

Temperature Range	Numerical Code
ON OFF	10
100°F (38C) 120°F (49C)	

All 3 phase heaters with thermostat must use a control box. See Control Systems page 30.

### EE Replacement Thermostats

Example:

Model Number: EE130210-000  
T-Stat Replacement: RSU10

Temperature Range	Sensing Unit
ON OFF	RSU10
100°F (38C) 120°F (49C)	

### ADAPTER FITTINGS

For the use of 0.75" or 1" ID heater hose, hose barb adapters are available. See below.

HB-1	1" NPT to 1" hose barb adapter. Installs in 1" NPT female inlet or outlet of the heater.
HB-3/4	1" NPT to 0.75" hose barb adapter. Installs in 1" NPT female inlet or outlet of the heater.

Engine Displacement	Model Number without Thermostat	Model Number with Thermostat	Volts	Watts	Phase	Amp
500 CID or less 8.2L or less	EE315800-000	EE315810-000	208	1500	3	4.2
	EE315200-000	EE315210-000	240	1500	3	3.6
	EE315400-000	EE315410-000	480	1500	3	1.8
500 - 600 CID 8.2 - 9.8L	EE320800-000	EE320810-000	208	2000	3	5.6
	EE320200-000	EE320210-000	240	2000	3	4.8
	EE320400-000	EE320410-000	480	2000	3	2.4
600 - 800 CID 9.8 - 13.1L	EE325800-000	EE325810-000	208	2500	3	6.9
	EE325200-000	EE325210-000	240	2500	3	6.0
	EE325400-000	EE325410-000	480	2500	3	3.0
800 - 1000 CID 13.1 - 16.4L	EE330800-000	EE330810-000	208	3000	3	8.3
	EE330200-000	EE330210-000	240	3000	3	7.2
	EE330400-000	EE330410-000	480	3000	3	3.6
1000 - 1350 CID 16.4 - 22.1L	EE340800-000	EE340810-000	208	4000	3	11.1
	EE340200-000	EE340210-000	240	4000	3	9.6
	EE340400-000	EE340410-000	480	4000	3	4.8
1350 - 1650 CID 22.1 - 27.0L	EE350800-000	EE350810-000	208	5000	3	13.9
	EE350200-000	EE350210-000	240	5000	3	12.0
	EE350400-000	EE350410-000	480	5000	3	6.0

## EE Model

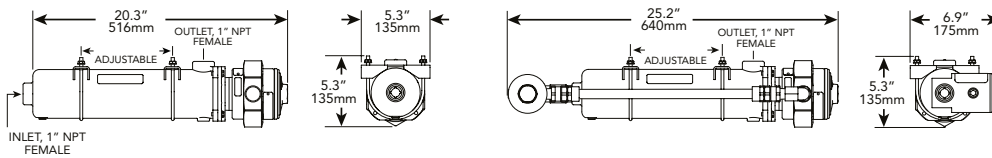

## Replacement Parts

Model Number without Thermostat	Model Number with Thermostat	Element Replacement
EE315800-000	EE315810-000	E01583E-15NA-00
EE315200-000	EE315210-000	E01523E-15NA-00
EE315400-000	EE315410-000	E01543E-15NA-00
EE320800-000	EE320810-000	E02083E-25NA-00
EE320200-000	EE320210-000	E02023E-25NA-00
EE320400-000	EE320410-000	E02043E-25NA-00
EE325800-000	EE325810-000	E02583E-30NA-00
EE325200-000	EE325210-000	E02523E-30NA-00
EE325400-000	EE325410-000	E02543E-30NA-00
EE330800-000	EE330810-000	E03083E-30NA-00
EE330200-000	EE330210-000	E03023E-30NA-00
EE330400-000	EE330410-000	E03043E-30NA-00
EE340800-000	EE340810-000	E04083E-50NA-00
EE340200-000	EE340210-000	E04023E-50NA-00
EE340400-000	EE340410-000	E04043E-50NA-00
EE350800-000	EE350810-000	E05083E-50NA-00
EE350200-000	EE350210-000	E05023E-50NA-00
EE350400-000	EE350410-000	E05043E-50NA-00

Common Replacement Parts available for all listed heaters	
Check Valve	RV-M
Flange	RF-L
Flange O-ring	TML-OR
Tank	RTL
MC-HL cable	PRP104301-029
Mounting Brackets	FK7

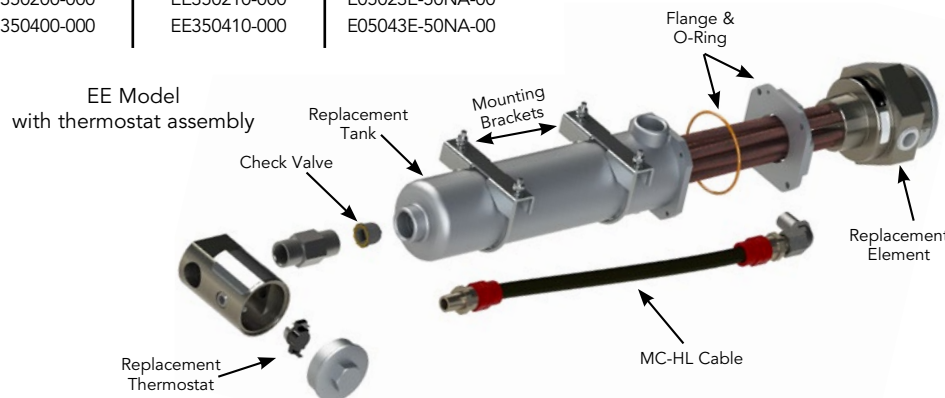

# Installation Instructions for Thermosiphon Engine Heaters

The HOTSTART engine heater uses thermosiphon action – the natural expansion and rising action of a heated fluid – to circulate heated coolant throughout an engine’s water jacket. Installation of the heating system is critical. Please refer to specific instructions that accompany your HOTSTART engine heater or visit [hotstart.com](http://hotstart.com) and search **Resources**.

**For “V” engines larger than eight cylinders or over 1000 CID (15 L), HOTSTART recommends using a HOTflow® heater. Please refer to pages 4-6 for heater selection.**

Prior to heater installation, inspect the coolant supply. When mixing coolant, only use deionized or distilled water and low-silicate antifreeze. Refer to your engine’s manufacturer recommendations. Do not exceed 60% antifreeze to 40% water ratio. Never add unmixed water and antifreeze to an engine. Do not add anti-leak or other coolant additives.

## PREPARING

- Drain and flush cooling system to remove any debris present in the engine’s cooling system.
- Select return port. The return port will allow heated coolant to return to the engine.
- Select supply port. The supply port will allow coolant to flow from the engine to the heater.
- Select fittings. Use the following table to determine the proper port fitting size for your heater:

CB/CL/SB/SL	500–3000 watts	1/2 inch NPT
CB/CL/SB/SL	3750–5000 watts	3/4 inch NPT
WL/EE	1500–5000 watts	3/4 inch NPT

- Select hoses. Use the following table to determine the minimum hose inner diameter for your heater:

CB/CL/SB/SL	500–3000 watts	3/4 inch
CB/CL/SB/SL	3750–5000 watts	1 inch
WL/EE	1500–5000 watts	1 inch

HOTSTART recommends installing valves to isolate the heating system in case of service. To minimize flow restriction, select full-flow ball isolation valves.

## MOUNTING

- Select a heater mounting position directly below the return port and at least 6 inches (15 cm) below the lowest point of the engine’s water jacket. Mount heater using the supplied mounting brackets and fasteners.

## PLUMBING

- Install isolation valves to port fittings.
- Route and install return hose. The return hose should continuously rise from the heater to the return port.
- Route and install supply hose. The supply hose should continuously descend from the supply port to the heater.
- Refill cooling system with coolant. To prevent air pockets, refill coolant with return hose removed.
- Start engine. Allow engine to run until engine thermostat opens, purging air from cooling system. Engine must be run to eliminate air from heating system before energizing heater.

## WIRING

- Connect heater to an appropriately rated power source. Ensure power source is grounded and in accordance with local and national electrical codes. If necessary, install control box:
  - If your heater is single-phase and rated up to 480 volts, your heater may be powered directly without the use of a control relay or contactor.
  - If your heater is three-phase or is single-phase and rated for over 480 volts, the heater thermostats must be used in a control circuit with a contactor for switching the main power to the heating elements.

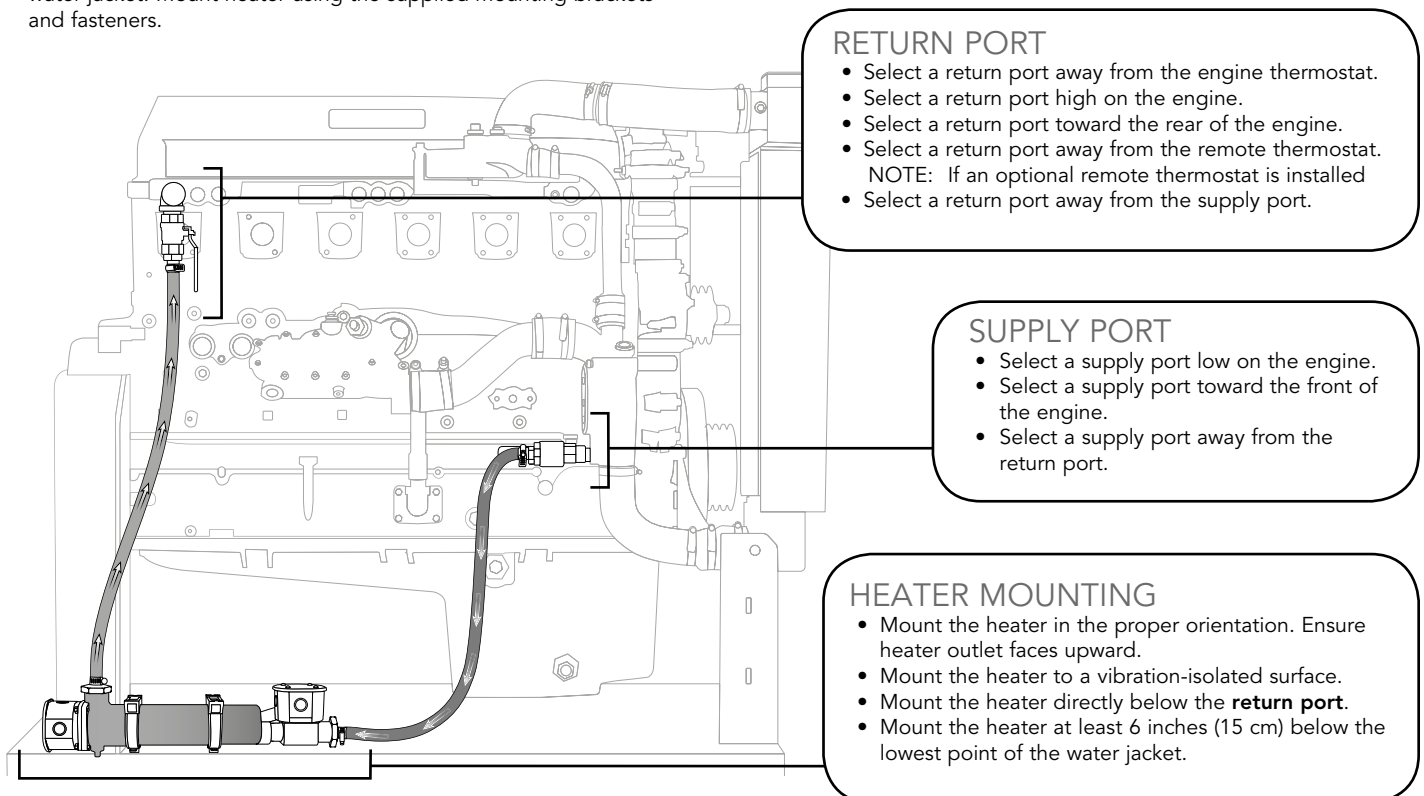

## SECTION 2

---





## Oil Heaters

Oil Heaters up to 277 V AC meet recognized CSA standards for safety or performance.

To specify temperature range of thermostat, insert code from chart in place of the **XX** in model number.

### Example:

Desired Temp. Range 80°–100°F  
Model Number: OW2121**XX**-000  
Order as: OW2121**08**-000

Temperature Range		Code
ON	OFF	
60°F (16°C)	80°F (27°C)	06
80°F (27°C)	100°F (38°C)	08
100°F (38°C)	120°F (49°C)	10

See p.21 for remote thermostat assembly part numbers.



Oil heater with Y-cord and remote thermostat.  
Complete with NEMA plug for 120/240 V only.

## DC Oil Heaters 12 V and 24 V

When used with a thermostat control, all DC oil heaters must use a DC relay.

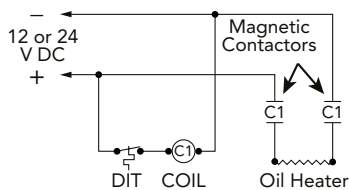

### 12 V DC/24 V DC CONTROL BOXES

25 Amps Maximum	12V 24V	JBMC330DC-12V JBMC330DC-24V
-----------------	------------	--------------------------------

Use a thermostat with all lube oil heaters to protect the oil from overheating. Lube oil heaters must always be installed in the sump with the entire heater submerged below the oil level at all times. See page 21 for remote thermostat part numbers.

**\*NOTE:** If heating gear oil (medium weight viscosity), HOTSTART recommends using low watt density heaters.

Oil Capacity	*Weathertight Heater Only	Weathertight With Thermostat	*Hazardous Location Heater Only	Volts	Watts	Amps	Watts/Sq Inch
<b>3/8" N.P.T. THREAD WITH A 2 1/8" (54mm) PROBE LENGTH</b>							
2 qt. (2L) or Less	OW005100-000	—	—	120	50	.4	20.0
	OW005200-000	—	—	240	50	.2	20.0
<b>1/2" N.P.T. THREAD WITH A 4" (101mm) PROBE LENGTH</b>							
2 - 6 qt. 2 - 5.7L	OW212100-000	OW2121XX-000	OE212100-000	120	125	1.0	24.6
	OW212200-000	OW2122XX-000	OE212200-000	240	125	.5	24.6
<b>3/4" N.P.T. THREAD WITH A 5" (127mm) PROBE LENGTH</b>							
1 - 5 gal. 3.8 - 19L	OW415100-000	OW4151XX-000	OE415100-000	120	150	1.3	<b>14.6*</b>
	OW415200-000	OW4152XX-000	OE415200-000	240	150	.6	<b>14.6*</b>
5 - 15 gal. 19 - 57L	OW430100-000	OW4301XX-000	OE430100-000	120	300	2.6	29.3
	OW430800-000	OW4308XX-000	OE430800-000	208	225	1.1	22.0
	OW430200-000	OW4302XX-000	OE430200-000	240	300	1.2	29.3
<b>1" N.P.T. THREAD WITH A 5 1/4" (133mm) PROBE LENGTH</b>							
1 - 5 gal. 3.8 - 19L	OW615100-000	OW6151XX-000	OE615100-000	120	150	1.3	<b>10.7*</b>
	OW615200-000	OW6152XX-000	OE615200-000	240	150	.6	<b>10.7*</b>
5 - 15 gal. 19 - 57L	OW630100-000	OW6301XX-000	OE630100-000	120	300	2.6	21.4
	OW630800-000	OW6308XX-000	OE630800-000	208	375	1.8	28.0
	OW630200-000	OW6302XX-000	OE630200-000	240	300	1.2	21.4
	—	—	OE630700-000	277	265	1.0	19.0
	—	—	OE630300-000	380	300	1.0	21.4
—	—	OE630400-000	480	300	0.6	21.4	
<b>1" N.P.T. THREAD WITH A 11 7/16" (297mm) PROBE LENGTH</b>							
15 - 30 gal. 57 - 113L	—	—	OE650100-100	120	500	4.2	15.0
	—	—	OE650200-100	240	500	2.1	15.0
	—	—	OE650400-100	480	500	1.0	15.0
	—	—	OE650500-100	575	500	0.9	15.0

\*Weathertight heater only models are furnished with a 4' (1.2m) oil- and heat-resistant power cord without plug. Hazardous Location heater only models are furnished with 18" (457mm) of lead wire for connection to the power leads in an approved splice box.

Oil Capacity	Volts	Watts	1/2" NPT with 4" (101mm) Probe Length	3/4" NPT with 4 7/8" (124mm) Probe Length	1" NPT with 5 3/8" (136mm) Probe Length	Amps	Watts Per Square Inch
2 qt. 2.0L or Less	12	75	OW207900-012	OW407900-012	—	6.3	1/2" — 14.7* WSI
	24	75	—	OW407900-024	—	3.1	3/4" — 7.3* WSI
2-6 qt. 2.0-2.7L	24	125	OW212900-024	—	—	5.2	24.6 WSI
1-5 gal. 3.8-19L	12	150	—	OW415900-012	OW615900-012	12.5	3/4" — 14.6* WSI
	24	150	—	OW415900-024	OW615900-024	6.3	1" — 10.7* WSI
5-15 gal. 19-57L	12	300	—	—	OW630900-012	25.0	3/4" — 29.3 WSI
	24	300	—	OW430900-024	OW630900-024	12.5	1" — 21.4 WSI
15-30 gal. 57-113L	24	500	—	—	OW650900-024	20.8	35.7 WSI

12 V DC and 24 V DC oil heaters can be powered directly from the battery, but will drain the battery very rapidly unless charged by an alternator or generator.



# Weathertight

OW Series Heater only

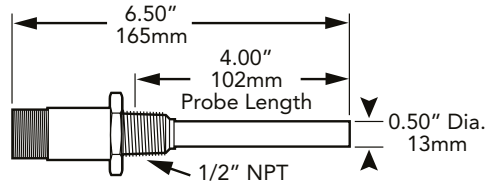
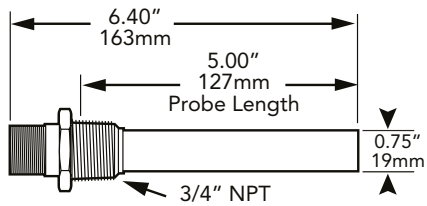
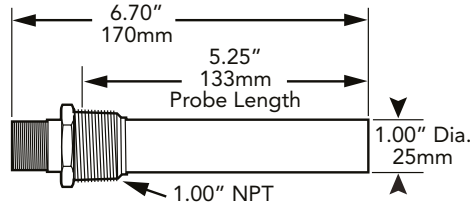

# Hazardous Location

OE Series Heater only

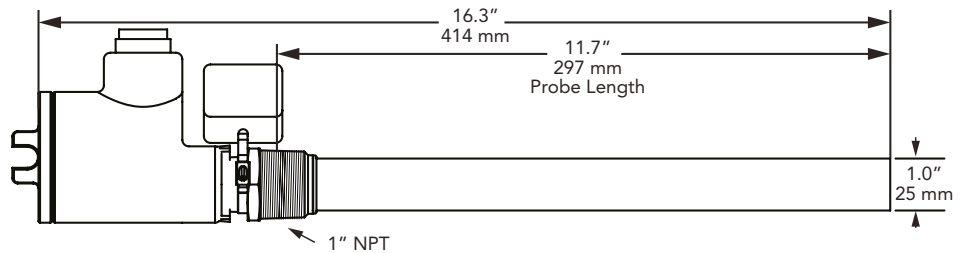
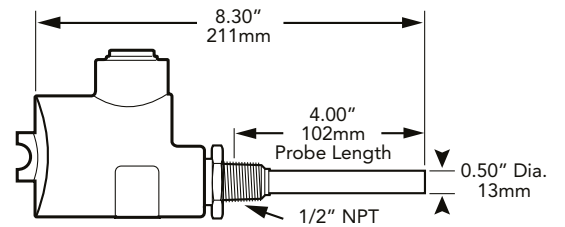
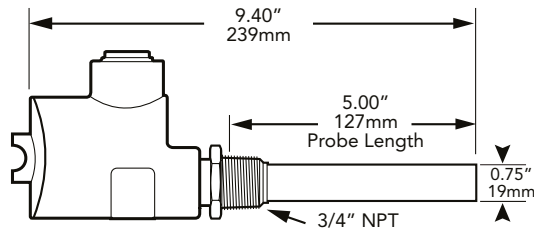
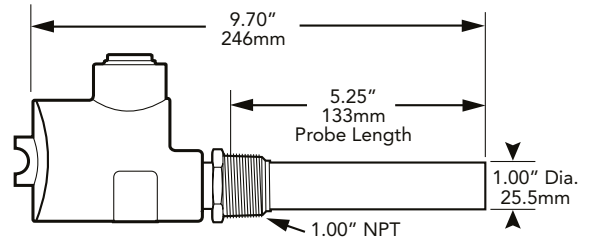

## REMOTE THERMOSTATS for OIL HEATERS

Weathertight	Hazardous Location	Temperature Range		Sensing Unit	Thread Size
		ON	OFF		
DIT68	DIT68EP	60°F (16°C)	80°F (27°C)	LSU-6	1/2" NPT
DIT810	DIT810EP	80°F (27°C)	100°F (38°C)	LSU-8	1/2" NPT
DIT1012	DIT1012EP	100°F (38°C)	120°F (49°C)	LSU-10	1/2" NPT
DIT1214	DIT1214EP	120°F (49°C)	140°F (60°C)	LSU-12	1/2" NPT

### Switch Capacity

- 120 V - 15amp
- 208 V - 10amp
- 240 V - 10amp
- 277 V - 10amp

12 V DC } Pilot Duty Only  
24 V DC }

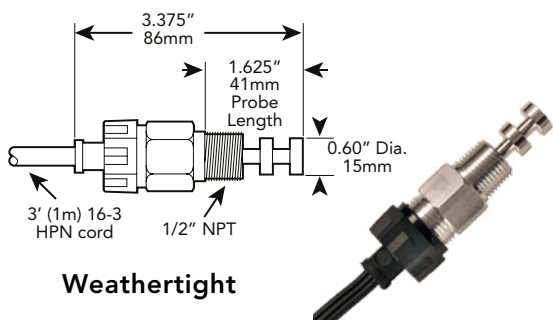

**Weathertight**

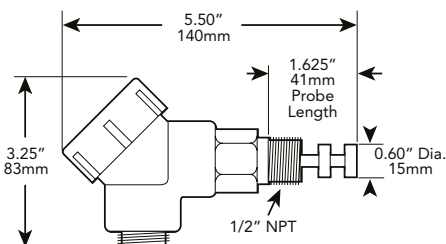

**Hazardous Location**



# Weathertight Industrial Immersion Heaters

## 2" NPT Thread



NEMA 4

## V-Clamp Threadless Design



NEMA 4

Oil Capacity	Fitting Style		Probe Length	Volts	Watts	Amps	Watts/Sq. In.
	2" NPT Thread	V-Clamp Threadless					
<b>SINGLE PHASE</b>							
30 - 45 Gallons	E01011W-15XA-00	E01011W-15XV-00	12" (305 mm)	120	1000	8.3	17.0
	E01081W-15XA-00	E01081W-15XV-00	12" (305 mm)	208	1000	4.8	17.0
	E01021W-15XA-00	E01021W-15XV-00	12" (305 mm)	240	1000	4.2	17.0
113-170L							
45 - 60 Gallons	E01511W-15XA-00	E01511W-15XV-00	12" (305 mm)	120	1500	12.5	17.0
	E01581W-15XA-00	E01581W-15XV-00	12" (305 mm)	208	1500	7.2	17.0
	E01521W-15XA-00	E01521W-15XV-00	12" (305 mm)	240	1500	6.3	17.0
170-227L							
60 - 90 Gallons	E02011W-15XA-00	E02011W-15XV-00	18" (457 mm)	120	2000	16.7	14.0
	E02081W-15XA-00	E02081W-15XV-00	18" (457 mm)	208	2000	9.6	14.0
	E02021W-15XA-00	E02021W-15XV-00	18" (457 mm)	240	2000	8.4	14.0
	E02041W-15XA-00	E02041W-15XV-00	18" (457 mm)	480	2000	4.2	14.0
227-341 L							
<b>THREE PHASE</b>							
30 - 45 Gallons	E01083W-10XA-00	E01083W-10XV-00	12" (305 mm)	208	1000	2.8	11.0
	E01023W-10XA-00	E01023W-10XV-00	12" (305 mm)	240	1000	2.4	11.0
	E01033W-10XA-00	E01033W-10XV-00	12" (305 mm)	380	1000	1.5	11.0
	E01043W-10XA-00	E01043W-10XV-00	12" (305 mm)	480	1000	1.2	11.0
113-170L							
45 - 60 Gallons	E01583W-15XA-00	E01583W-15XV-00	12" (305 mm)	208	1500	4.2	17.0
	E01523W-15XA-00	E01523W-15XV-00	12" (305 mm)	240	1500	3.6	17.0
	E01533W-15XA-00	E01533W-15XV-00	12" (305 mm)	380	1500	2.3	17.0
	E01543W-15XA-00	E01543W-15XV-00	12" (305 mm)	480	1500	1.8	17.0
170-227L							
60 - 90 Gallons	E02083W-15XA-00	E02083W-15XV-00	18" (457 mm)	208	2000	5.6	14.0
	E02023W-15XA-00	E02023W-15XV-00	18" (457 mm)	240	2000	4.8	14.0
	E02033W-15XA-00	E02033W-15XV-00	18" (457 mm)	380	2000	3.0	14.0
	E02043W-15XA-00	E02043W-15XV-00	18" (457 mm)	480	2000	2.4	14.0
227-341 L							

### Heaters with Thermostats

To specify temperature range of thermostat, insert numerical code from chart in place of the **X** in model number.

#### Example:

Desired Temp. Range: 60° – 80°F

Model Number: E01011W-15XA-00

Order as: E01011W-15**6**A-00

### Temperature Range

ON OFF

40°F (4°C)	60°F (16°C)	4
60°F (16°C)	80°F (27°C)	6
80°F (27°C)	100°F (38°C)	8
100°F (38°C)	120°F (49°C)	1

### Numerical Code

Industrial Immersion Heaters are also available for coolants and other process heating. Call HOTSTART for information on these heating solutions.

Models for larger capacities than shown are available. Call HOTSTART to speak with a sales representative to learn more about weathertight forced circulation oil heating systems.

### OSM Model



HOTSTART immersion heaters include a fixed-setting, built-in thermostat.

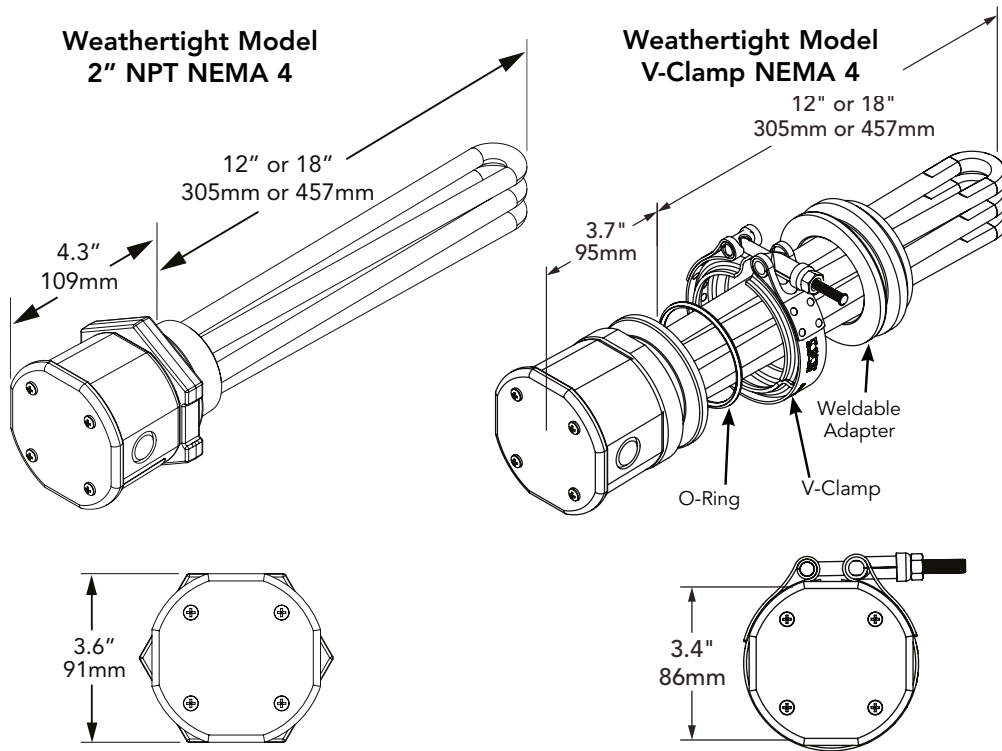

### Fixed Thermostat Assembly

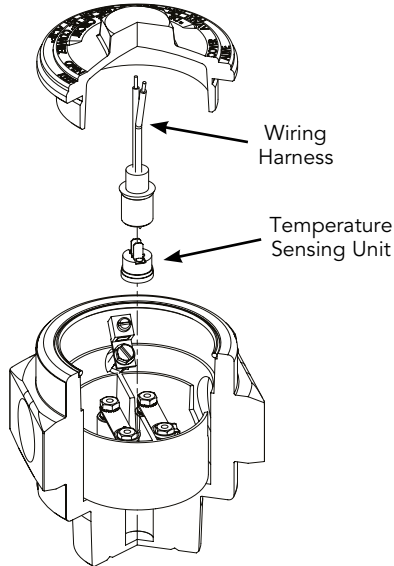

TEMPERATURE RANGE		Sensing Unit
ON	OFF	
40°F (4°C)	60°F (16°C)	HLC-4
60°F (16°C)	80°F (27°C)	HLC-6
80°F (27°C)	100°F (38°C)	HLC-8
100°F (38°C)	120°F (49°C)	HLC-10

#### ELECTRICAL RATING

15 Amps at 120 Vac  
 10 Amps at 240 Vac  
 10 Amps at 277 Vac

Replacement thermostat assemblies include temperature sensing unit and wiring harness.

## Weathertight Industrial Immersion Heaters

Element assembly includes **O-ring** only.

Installation kit sold separately.

#### V-CLAMP INSTALL KIT

Part Number	Parts Included
VC-SK	Steel weldable adapter V-Clamp O-Ring

#### NOTES:

On applications where level of fluid is subject to change, a liquid level switch mounted a minimum of 3–4" (76–102mm) above element is recommended. **Liquid level switch is not included with heater.**

All 380 V and 480 V heaters must be used in conjunction with contactor and control transformer.

All three phase models must be used with a contactor. See page 30.

Higher or lower temperature ranges are available. Consult HOTSTART.

# Hazardous Location Immersion Heaters

## 2" NPT Thread



E474204  
HEATER FOR USE IN  
HAZARDOUS LOCATIONS

### Certifications:

Class I Div. 1 Group C & D T3A

Class I Zone 1 Group IIB T3

IECEX UL 18.0071X DEMKO 18 ATEX 1943X Rev. 0

©II 2 G Ex db IIB T3 Gb & Ex db IIB T3 Gb  
CE 0539

Ambient temp. -40 °C +40 °C IP66 NEMA  
Type 4

## V-Clamp Threadless Design



E474204  
HEATER FOR USE IN  
HAZARDOUS LOCATIONS

### Certifications:

Class I Div. 1 Group C & D T3A

Class I Zone 1 Group IIB T3

IECEX UL 18.0071X DEMKO 18 ATEX 1943X Rev. 0

©II 2 G Ex db IIB T3 Gb & Ex db IIB T3 Gb  
CE 0539

Ambient temp. -40 °C +40 °C IP66 NEMA  
Type 4

Oil Capacity	Fitting Style		Probe Length	Volts	Watts	Amps	Watts/ Sq. In.
	2" NPT Thread	V-Clamp Threadless					
<b>SINGLE PHASE</b>							
30 - 45 Gallons 113-170L	E01011E-15XA-00	E01011E-15XV-00	12" (305 mm)	120	1000	8.3	17.0
	E01081E-15XA-00	E01081E-15XV-00	12" (305 mm)	208	1000	4.8	17.0
	E01021E-15XA-00	E01021E-15XV-00	12" (305 mm)	240	1000	4.2	17.0
45 - 60 Gallons 170-227L	E01511E-15XA-00	E01511E-15XV-00	12" (305 mm)	120	1500	12.5	17.0
	E01581E-15XA-00	E01581E-15XV-00	12" (305 mm)	208	1500	7.2	17.0
	E01521E-15XA-00	E01521E-15XV-00	12" (305 mm)	240	1500	6.3	17.0
60 - 90 Gallons 227-341 L	E02011E-15XA-00	E02011E-15XV-00	18" (457 mm)	120	2000	16.7	14.0
	E02081E-15XA-00	E02081E-15XV-00	18" (457 mm)	208	2000	9.6	14.0
	E02021E-15XA-00	E02021E-15XV-00	18" (457 mm)	240	2000	8.4	14.0
	E02041E-15XA-00	E02041E-15XV-00	18" (457 mm)	480	2000	4.2	14.0
<b>THREE PHASE</b>							
30 - 45 Gallons 113-170L	E01083E-10XA-00	E01083E-10XV-00	12" (305 mm)	208	1000	2.8	11.0
	E01023E-10XA-00	E01023E-10XV-00	12" (305 mm)	240	1000	2.4	11.0
	E01033E-10XA-00	E01033E-10XV-00	12" (305 mm)	380	1000	1.5	11.0
	E01043E-10XA-00	E01043E-10XV-00	12" (305 mm)	480	1000	1.2	11.0
45 - 60 Gallons 170-227L	E01583E-15XA-00	E01583E-15XV-00	12" (305 mm)	208	1500	4.2	17.0
	E01523E-15XA-00	E01523E-15XV-00	12" (305 mm)	240	1500	3.6	17.0
	E01533E-15XA-00	E01533E-15XV-00	12" (305 mm)	380	1500	2.3	17.0
	E01543E-15XA-00	E01543E-15XV-00	12" (305 mm)	480	1500	1.8	17.0
60 - 90 Gallons 227-341 L	E02083E-15XA-00	E02083E-15XV-00	18" (457 mm)	208	2000	5.6	14.0
	E02023E-15XA-00	E02023E-15XV-00	18" (457 mm)	240	2000	4.8	14.0
	E02033E-15XA-00	E02033E-15XV-00	18" (457 mm)	380	2000	3.0	14.0
	E02043E-15XA-00	E02043E-15XV-00	18" (457 mm)	480	2000	2.4	14.0

### Heaters with Thermostats

To specify temperature range of thermostat, insert numerical code from chart in place of the **X** in model number.

#### Example:

Desired Temp. Range: 60° - 80°F

Model Number: E01011E-15**XA**-00

Order as: E01011E-15**6A**-00

### Temperature Range

ON OFF

40°F (4°C)	60°F (16°C)	4
60°F (16°C)	80°F (27°C)	6
80°F (27°C)	100°F (38°C)	8
100°F (38°C)	120°F (49°C)	1

### Numerical Code

Industrial Immersion Heaters are also available for coolants and other process heating. Call HOTSTART for information on these heating solutions.

Models for larger capacities than shown are available. Call HOTSTART to speak with a sales representative to learn more about hazardous location forced circulation oil heating systems.

### OSE Model



HOTSTART hazardous location immersion heaters are available with built in, fixed thermostat or RTD/Thermocouple.

## Hazardous Location Immersion Heaters

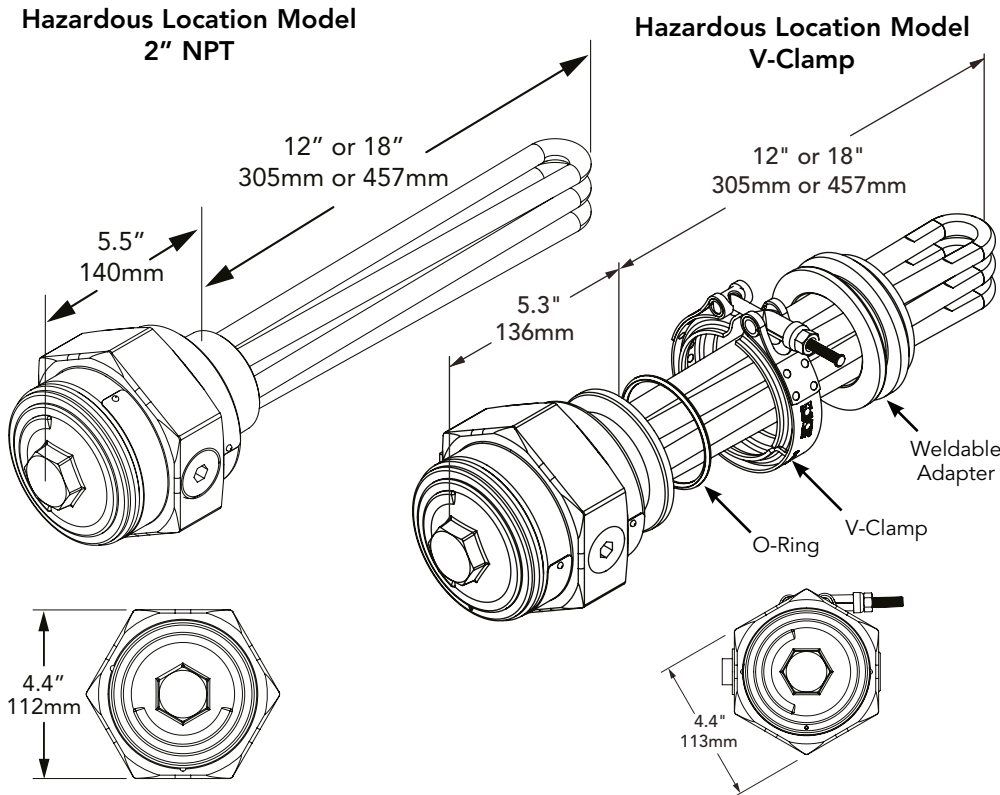

Element assembly includes **O-ring and V-Clamp**.

Weldable adaptor sold separately.

Part Number	Parts Included
VC-STA	Steel weldable adaptor

### Fixed Thermostat Assembly

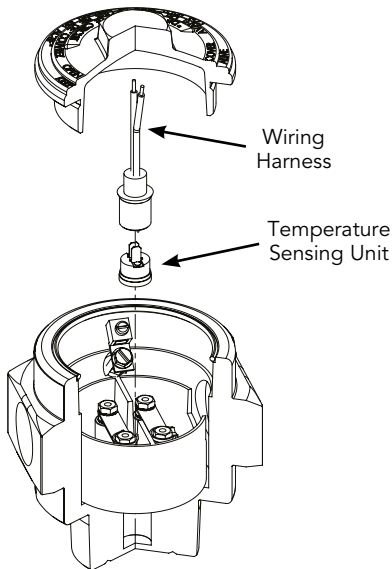

TEMPERATURE RANGE ON	TEMPERATURE RANGE OFF	Sensing Unit
40°F (4°C)	60°F (16°C)	HLC-4
60°F (16°C)	80°F (27°C)	HLC-6
80°F (27°C)	100°F (38°C)	HLC-8
100°F (38°C)	120°F (49°C)	HLC-10

#### ELECTRICAL RATING

15 Amps at 120 Vac  
 10 Amps at 240 Vac  
 10 Amps at 277 Vac

Replacement thermostat assemblies include temperature sensing unit and wiring harness.

### NOTES:

On applications where level of fluid is subject to change, a liquid level switch mounted a minimum of 3–4" (76–102mm) above element is recommended. **Liquid level switch is not included with heater.**

All 380 V and 480 V heaters must be used in conjunction with contactor and control transformer.

All three phase heaters must be used with a contactor. See page 30.

Higher or lower temperature ranges are available. Consult HOTSTART.

## SECTION 3





## Remote Thermostats for Weathertight and Hazardous Location Oil Heaters (see p.21 for model numbers)

REMOTE THERMOSTATS for OIL HEATERS					
Weathertight	Hazardous Location	Temperature Range		Sensing Unit	Thread Size
		ON	OFF		
DIT68	DIT68EP	60°F (16°C)	80°F (27°C)	LSU-6	1/2" NPT
DIT810	DIT810EP	80°F (27°C)	100°F (38°C)	LSU-8	1/2" NPT
DIT1012	DIT1012EP	100°F (38°C)	120°F (49°C)	LSU-10	1/2" NPT
DIT1214	DIT1214EP	120°F (49°C)	140°F (60°C)	LSU-12	1/2" NPT

Switch Capacity	
120 V - 15amp	
208 V - 10amp	
240 V - 10amp	
277 V - 10amp	
12 V DC	} Pilot Duty Only
24 V DC	

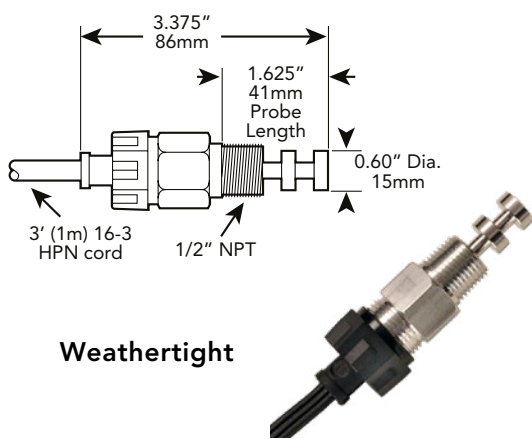

**Weathertight**

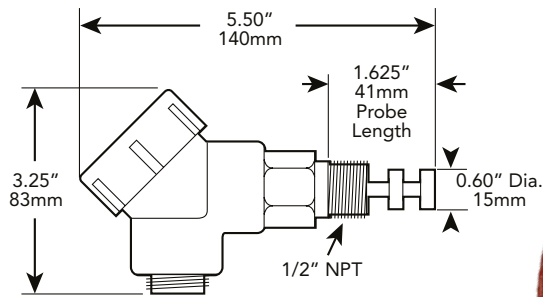

**Hazardous Location**



## Remote Adjustable Thermostat for TPS Thermosiphon Engine Heater (see p.7 for model numbers)

### 5/8" HB x 5/8" HB

Part Number	Adjustable Range Temperature Setting	Sensing Unit
TFTA-5/8HB	Adjustable 90°-130°F (32°-54°C)	FSU90-130

Part number does not include "Y" cord

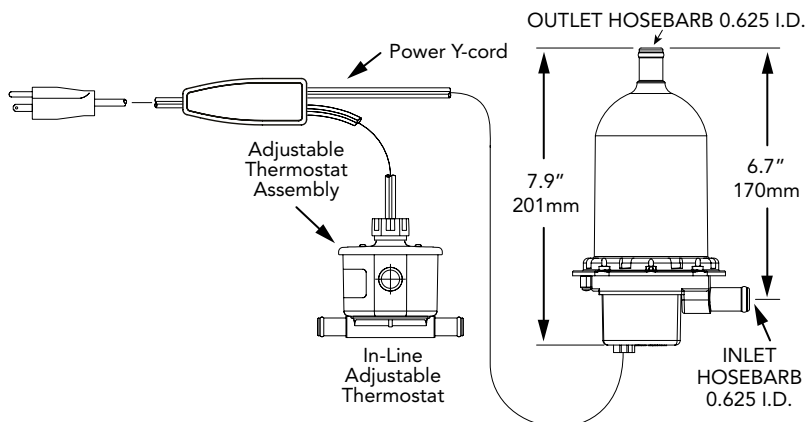
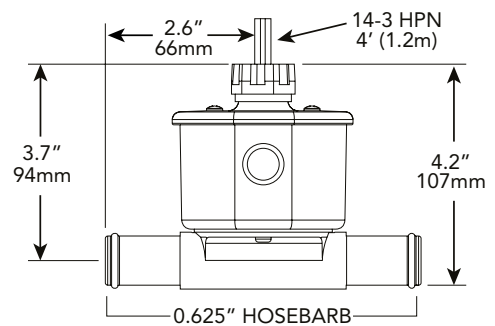

When using a thermostat above rated capacity or on 3 phase applications, select the proper control box with transformer and contactor as shown on page 30.

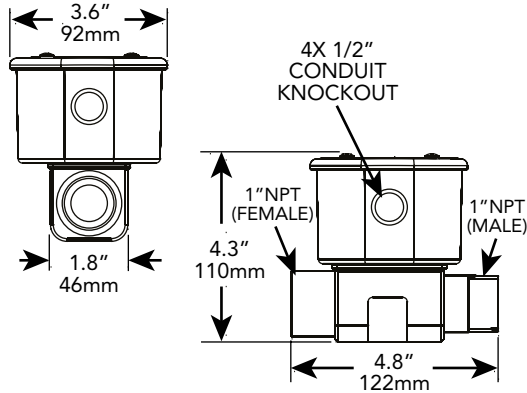

## 1" NPT female x 1" NPT male CONDUIT TYPE ENCLOSURE

Part Number	Temperature Setting		Maximum Capacity Ratings		
	On	Off	120/240V	277V	480V
TFTC8-200	80°F (27°C)	100°F (38°C)	25 amp	22 amp	12.5 amp
TFTC10-200	100°F (38°C)	120°F (49°C)	25 amp	22 amp	12.5 amp
TFTC12-200	120°F (49°C)	140°F (60°C)	25 amp	22 amp	12.5 amp
TFTCA-200	Adjustable 90°–130°F (32°–54°C)		25 amp	22 amp	12.5 amp

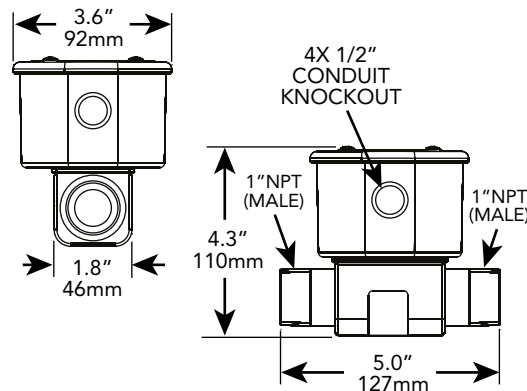

## 1" NPT male x 1" NPT male CONDUIT TYPE ENCLOSURE

Part Number	Temperature Setting		Maximum Capacity Ratings		
	On	Off	120/240V	277V	480V
TFTC8-220	80°F (27°C)	100°F (38°C)	25 amp	22 amp	12.5 amp
TFTC10-220	100°F (38°C)	120°F (49°C)	25 amp	22 amp	12.5 amp
TFTC12-220	120°F (49°C)	140°F (60°C)	25 amp	22 amp	12.5 amp
TFTCA-220	Adjustable 90°–130°F (32°–54°C)		25 amp	22 amp	12.5 amp

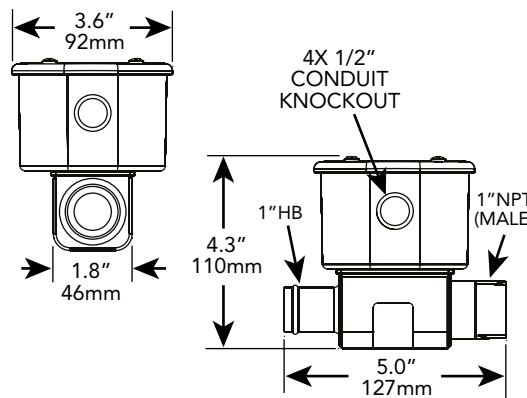

## 1" hose barb x 1" NPT male CONDUIT TYPE ENCLOSURE

Part Number	Temperature Setting		Maximum Capacity Ratings		
	On	Off	120/240V	277V	480V
TFTC8-240	80°F (27°C)	100°F (38°C)	25 amp	22 amp	12.5 amp
TFTC10-240	100°F (38°C)	120°F (49°C)	25 amp	22 amp	12.5 amp
TFTC12-240	120°F (49°C)	140°F (60°C)	25 amp	22 amp	12.5 amp
TFTCA-240	Adjustable 90°–130°F (32°–54°C)		25 amp	22 amp	12.5 amp

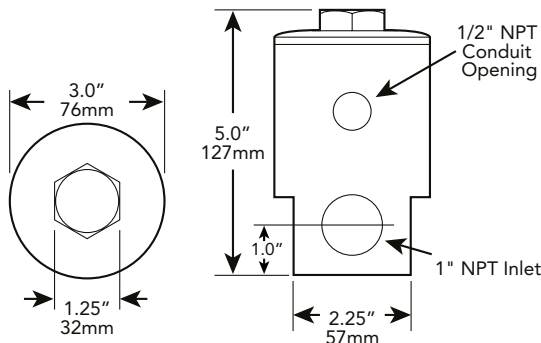

## HAZARDOUS LOCATION CONDUIT TYPE ENCLOSURE

Part Number	Temperature Setting		Maximum Capacity Ratings		
	On	Off	120/240V	277V	480V
TFT10ER	100°F (38°C)	120°F (49°C)	25 amp	22 amp	12.5 amp

When using a thermostat above rated capacity or on 3 phase applications, select the proper control box with transformer and contactor as shown on page 30.

## 1" NPT female x 1" NPT male

20 amp



### CORD CONNECTED

Part Number	Temperature Setting		Maximum Capacity Ratings	
	On	Off	120/240V	277V
TFT8-200	80°F (27°C)	100°F (38°C)	20 amp	20 amp
TFT10-200	100°F (38°C)	120°F (49°C)	20 amp	20 amp
TFT12-200	120°F (49°C)	140°F (60°C)	20 amp	20 amp
TFTA-200	Adjustable 90°–130°F (32°–54°C)		20 amp	20 amp

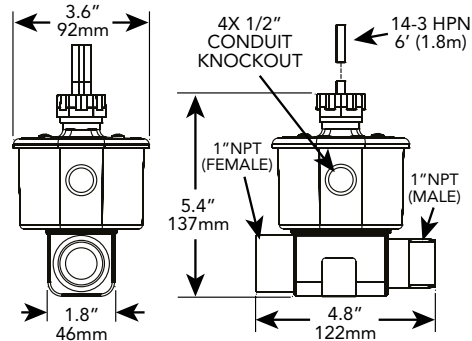

## 1" NPT male x 1" NPT male

### CORD CONNECTED

Part Number	Temperature Setting		Maximum Capacity Ratings	
	On	Off	120/240V	277V
TFT8-220	80°F (27°C)	100°F (38°C)	20 amp	20 amp
TFT10-220	100°F (38°C)	120°F (49°C)	20 amp	20 amp
TFT12-220	120°F (49°C)	140°F (60°C)	20 amp	20 amp
TFTA-220	Adjustable 90°–130°F (32°–54°C)		20 amp	20 amp

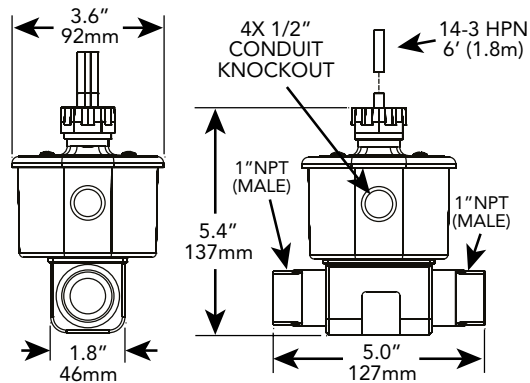

## 1" hose barb x 1" NPT male

### CORD CONNECTED

Part Number	Temperature Setting		Maximum Capacity Ratings	
	On	Off	120/240V	277V
TFT8-240	80°F (27°C)	100°F (38°C)	20 amp	20 amp
TFT10-240	100°F (38°C)	120°F (49°C)	20 amp	20 amp
TFT12-240	120°F (49°C)	140°F (60°C)	20 amp	20 amp
TFTA-240	Adjustable 90°–130°F (32°–54°C)		20 amp	20 amp

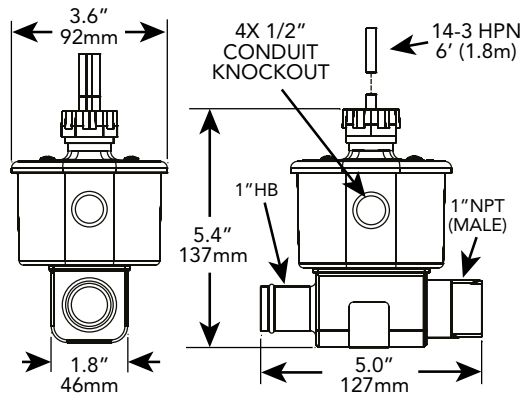

## REMOTE ADJUSTABLE With 5' (1.5m) Capillary Probe

Part Number	Adjustable Range Temperature Setting	Maximum Capacity Ratings		
		120/208/240V	277V	480V
AT6525	65 - 250°F (18 - 121°C) (Open or Off Setting) Differential 4°F (2.2°C) (Close or On Setting)	25 amp	22 amp	5 amp

ATW  
Aluminum  
Well for  
AT6525

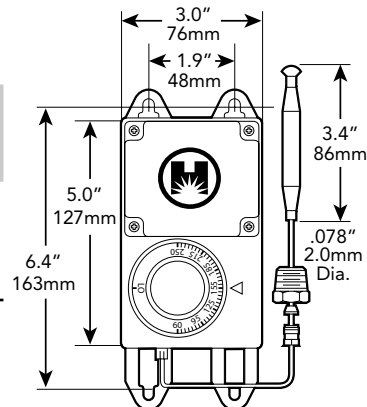
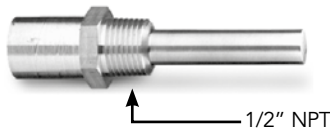

Control systems allow for quick electrical installation of all HOTSTART engine heaters. They are designed as a time and labor saving component. Control systems are especially useful on installations that require two coolant heaters or combinations of a coolant heater and oil heater/hydraulic heater etc.

All control boxes on this page are NEMA 4, 12 & IP66.

## CONTROL SYSTEMS

CONTROL SYSTEMS featuring AUTOMATIC SHUTDOWN DEVICES  
With 24 V DC Relay

Amps	Volts	1 Heater, 1 Thermostat per application	2 Heaters, 2 Thermostats per application
30A Max	120	JBC11-100	JBC21-100
30A Max	208	JBC18-100	JBC28-100
30A Max	240	JBC12-100	JBC22-100
30A Max	400	JBC1A-100	JBC2A-100
30A Max	480	JBC14-100	JBC24-100
30A Max	575	JBC15-100	JBC25-100



Model JBC14-100

See wiring schematic page 31



Model JBC24-100

See wiring schematic page 31

All HOTSTART heaters with thermostat, operating on three phase current (at any voltage), require the use of a control system with a 3-pole contactor. All HOTSTART heaters with thermostat, operating over 480 V (single or three phase) require a control system to reduce the primary voltage to 120 V for the control circuit. For increased thermostat life, use a control system on all heaters above 277 V either single or three phase.

All control boxes can be used with either single or three phase heaters. Control boxes are available in Hazardous Location models - contact factory for part number.

For heater protection and power savings, HOTSTART recommends de-energizing the heater when engine is running. Control boxes are supplied with a 24 V relay to de-energize the heater upon engine start-up.

## Wiring Schematic for JBC14-100

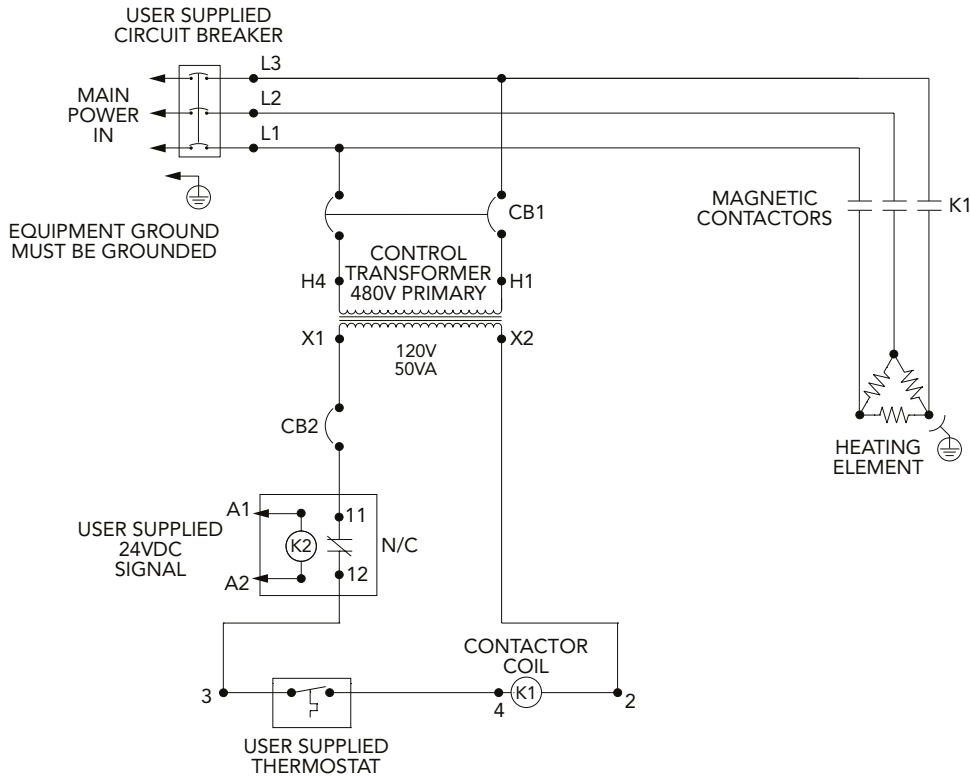

To control one 480 V heater at maximum 30 amps on manual start engine.

## Wiring Schematic for JBC24-100

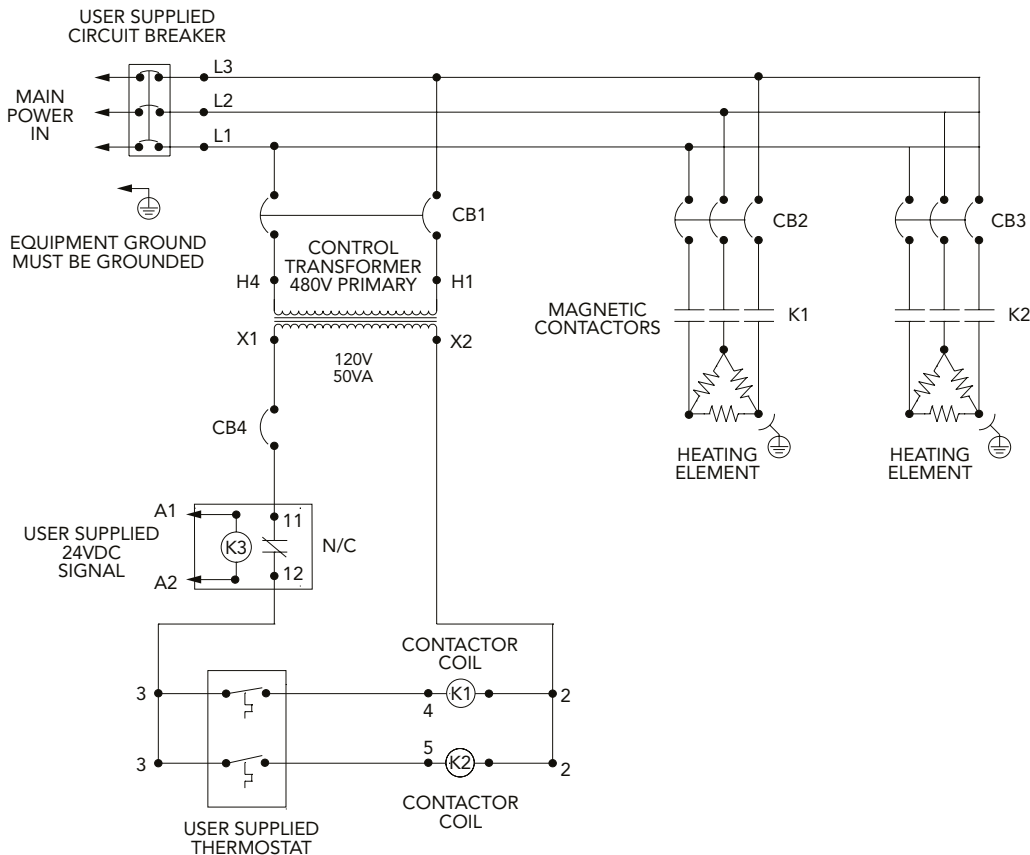

To control two 480 V heaters at maximum 30 amps on automatic start engines.

## Control Systems



Model JBC14-100



Model JBC24-100

## POWER DISTRIBUTION BOX

Use to simplify wiring on equipment when a variety of heaters and controls are required. All models have ten, 25 Amp terminal blocks. Power Distribution Boxes are rated NEMA 4 and IP66/67



PDB-000



A6553-2

Part Number	Number of Openings
PDB-000	8*

\*Box comes assembled with 4 strain relief connectors. For additional connectors, order part# A6553-2.

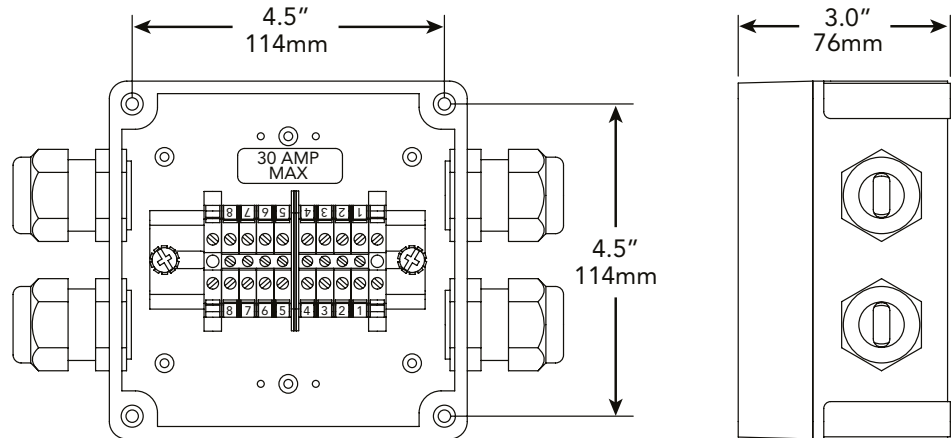

## OIL PRESSURE SWITCH

For automatic cut-off of heaters when engine starts.

**Maximum Current Capacity:**  
 120 V/208 V/240 V/277 V — 25 Amps  
 380 V/480 V/575 V — 15 Amps  
 Two pole single throw

To prevent overheating of the heating element on standby equipment and automatic start engines, HOTSTART recommends turning the coolant heater off when the engine is running. A pressure switch that senses engine oil pressure is utilized to shut the heater off on increase of oil pressure and to turn the heater on when engine oil pressure drops.



NEMA 1

Part Number	Enclosure Type
PS252	Dry Locations
PS252R	Dry Locations (Reverse Action)
PS252WT	Wet Locations
PS252EP	Hazardous Locations



## SECTION 4



# Battery Heating Pads



Battery heater not recommended for nickel cadmium batteries. When batteries are placed in an insulated battery box, a thermostat is recommended to sense battery box temperature to prevent overheating the battery.

### Standard Pad for Single Battery

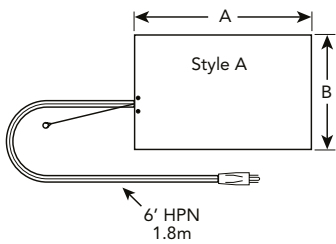

### Special Pads for Multiple Batteries

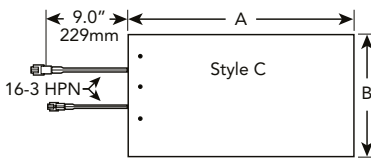
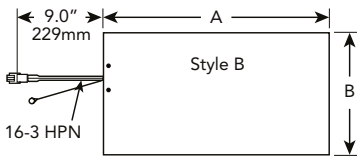

Model Number	Volts	Watts	Amps	Nominal Dimensions		Battery Size	Style
				A	B		
KB5015	120	50	.42	12.75" (324mm)	8.25" (210mm)	4D	A
KB5015-S	120	50	.42	12.75" (324mm)	8.25" (210mm)	4D	B
KB5015-D	120	50	.42	12.75" (324mm)	8.25" (210mm)	4D	C
KB7515	120	75	.63	19.5" (495mm)	10.5" (267mm)	8D	A
KB7515-S	120	75	.63	19.5" (495mm)	10.5" (267mm)	8D	B
KB7515-D	120	75	.63	19.5" (495mm)	10.5" (267mm)	8D	C
KB7523	240	75	.31	19.5" (495mm)	10.5" (267mm)	8D	A
KB7523-S	240	75	.31	19.5" (495mm)	10.5" (267mm)	8D	B
KB7523-D	240	75	.31	19.5" (495mm)	10.5" (267mm)	8D	C

### Typical Connection - 2 Batteries on Each Side of Vehicle

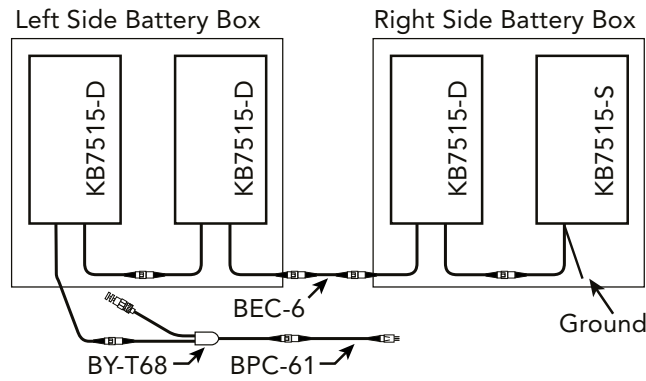

### Accessories For Multiple Battery Heating

#### EXTENSION CORDS

Part Number	Length
BEC-2	2' (0.7m)
BEC-4	4' (1.2m)
BEC-6	6' (1.8m)
BEC-8	8' (2.4m)

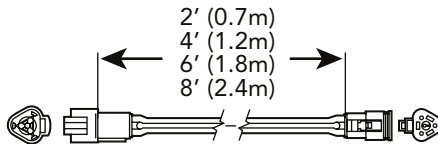

#### POWER SUPPLY CORDS

Part Number	Length	Volts
BPC-31	3' (1m)	120
BPC-32	3' (1m)	240
BPC-61	6' (1.8m)	120
BPC-62	6' (1.8m)	240

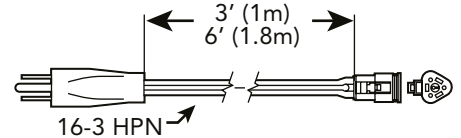

#### THERMOSTAT & "Y" CORD ASSEMBLY

Part Number	Temperature Control	
	On	Off
BY-T68	60°F (16°C)	80°F (27°C)

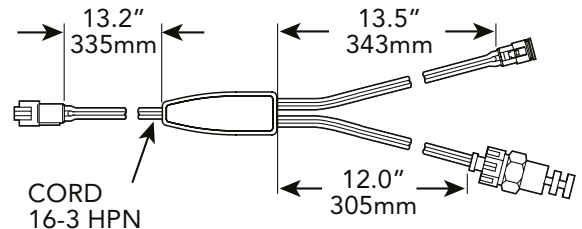

**UL RECOGNIZED BATTERY THERMAL WRAP — WITH THERMOSTAT**  
 Thermostat range: 60 °F - 80 °F (16 °C - 27 °C)

Select wrap based on either Battery Group OR Battery Perimeter		Replacement Strap BW-S-55 for wrap lengths of 34", 42" and 50" Replacement Strap BW-S-80 for wrap lengths of 58", 66" and 74"				
Battery Group*	Battery Perimeter	Model Number	Volts	Watts	Wrap Length	72" Power Cord**
22NF	24 - 32" (610 - 813 mm)	BW0513006S-000	120	50	34" (864 mm)	BPC-61
		BW0523006S-000	240	50	34" (864 mm)	BPC-62
24, 24F, 24H, 24R, 24T, 25, 27, 27H, 34, 34R, 35, 75, 78, GC2	32 - 40" (813 - 1016 mm)	BW0613806S-000	120	65	42" (1067 mm)	BPC-61
		BW0623806S-000	240	65	42" (1067 mm)	BPC-62
30H, 31	40 - 48" (1016 - 1219 mm)	BW0814606S-000	120	80	50" (1270 mm)	BPC-61
		BW0824606S-000	240	80	50" (1270 mm)	BPC-62
2E	48 - 56" (1219 - 1422 mm)	BW1015406S-000	120	100	58" (1473 mm)	BPC-61
		BW1025406S-000	240	100	58" (1473 mm)	BPC-62
4D, 6D	56 - 64" (1422 - 1626 mm)	BW1316206S-000	120	130	66" (1676 mm)	BPC-61
		BW1326206S-000	240	130	66" (1676 mm)	BPC-62
8D	64 - 72" (1626 - 1829 mm)	BW1617006S-000	120	160	74" (1880 mm)	BPC-61
		BW1627006S-000	240	160	74" (1880 mm)	BPC-62

**EURO BATTERY THERMAL WRAP FOR SCHUKO PLUG— WITH THERMOSTAT**  
 Thermostat range: 60 °F - 80 °F (16 °C - 27 °C)

Select wrap based on either Battery Group OR Battery Perimeter		Replacement Strap BW-S-55 for wrap lengths of 34", 42" and 50" Replacement Strap BW-S-80 for wrap lengths of 58", 66" and 74"				
Battery Group*	Battery Perimeter	Model Number	Volts	Watts	Wrap Length	72" Power Cord**
22NF	24 - 32" (610 - 813 mm)	BW0523006S-100	240	50	34" (864 mm)	BPC-62E
24, 24F, 24H, 24R, 24T, 25, 27, 27H, 34, 34R, 35, 75, 78, GC2	32 - 40" (813 - 1016 mm)	BW0623806S-100	240	65	42" (1067 mm)	BPC-62E
30H, 31	40 - 48" (1016 - 1219 mm)	BW0824606S-100	240	80	50" (1270 mm)	BPC-62E
2E	48 - 56" (1219 - 1422 mm)	BW1025406S-100	240	100	58" (1473 mm)	BPC-62E
4D, 6D	56 - 64" (1422 - 1626 mm)	BW1326206S-100	240	130	66" (1676 mm)	BPC-62E
8D	64 - 72" (1626 - 1829 mm)	BW1627006S-100	240	160	74" (1880 mm)	BPC-62E

\* Not all battery groups listed. For wrap sizing, consult the factory.

\*\* Power cord sold separately. For other cord lengths, consult the factory.

Battery wrap comes with a 9" (229 mm) pigtail. BPC-61 and BPC-62 have a NEMA plug. BPC-62E has a Schuko plug. **Please order the necessary power cord to complete your wrap assembly.**

UL Recognized thermostatically controlled battery thermal wraps provide optimum heating regardless of ambient temperature. At 80 °F (27 °C), the battery will achieve maximum cold cranking amps.

- Thermostat will eliminate battery damage caused by overheating and acid spill.
- Adjustable strap included for securing wrap around the battery.
- For optimized heating, properly overlap the wrap and have the thermostat stay in contact with the battery. Maximum allowable overlap is 10" (25 cm).
- If placed inside a case or box, HOTSTART recommends a minimum clearance of 1.5" (38 mm) between battery and enclosure wall.
- Euro battery wraps not UL Recognized.

**Battery Thermal Wrap**

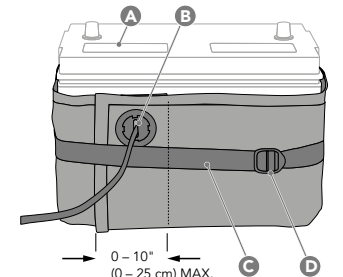

Battery wrap installation, showing battery (A), cord (B), strap (C) and buckle (D). Maximum overlap is 10 inches (25 cm).

Optional Y-Cords for connecting two battery heating wraps. NEMA Plug with 16-3 HPN cable or Schuko Plug with H05RN-F cable available.

**"Y" CORD ASSEMBLY**

Part Number	Voltage	Plug Type
BW-Y-1	120	NEMA (US)
BW-Y-2	240	NEMA (US)
BW-Y-E	230	Schuko (Euro)

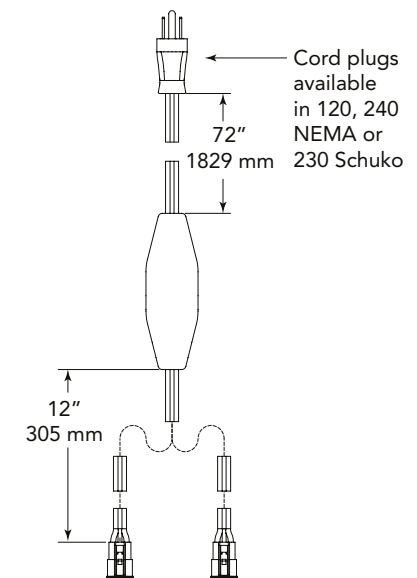

## Battery Thermal Wrap



### BATTERY THERMAL WRAP — NO THERMOSTAT

Model Number	Volts	Watts	Length
KBW5015-000	120	50	28" (711 mm)
KBW8015-000	120	80	36" (914 mm)
KBW16015-000	120	160	72" (1829 mm)

Prolong the life of your battery with HOTSTART thermal battery wraps. Wraps without a thermostart are not UL Recognized.

- Durable, fire-retardant vinyl cover that resists oils and acids.
- All standard battery pads and battery wraps come with 6' (1.8 m) grounded cord and plug.
- Fast, easy installation.
- Boosts battery cranking power as much as 75%.

### Versatile and Easy to Install

HOTSTART adhesive pad heaters can be used on oil pans, hydraulic reservoirs, engine blocks, hydraulic cylinders and diesel fuel tanks.

- Easy peel and stick application.
- Etched foil heating element for optimal heat transfer and long life.
- Durable silicone/fiberglass cover resists abrasion.
- 120 V models are assembled with a standard 6' (1.8m) HPN cord and plug. 240 V models include 6' (1.8m) HPN cord without plug.

## Silicone Pad Heaters



Not for use on batteries

Model Number	Volts	Watts	Dimensions
AF10015 AF10024	120 240	100 100	4" x 5" (102mm x 127mm)
AF15015 AF15024	120 240	150 150	4" x 5" (102mm x 127mm)
AF25015 AF25024	120 240	250 250	5" x 6" (127mm x 152mm)
AF40015 AF40024	120 240	400 400	6" x 8" (152mm x 203mm)

Application Guideline	100 Watt	150 Watt	250 Watt	400 Watt
Engine oil pan	2 - 5 quarts 1.9 - 4.7L	5 - 8 quarts 4.7 - 7.5 L	2 - 5 gallons 7.5 - 19.0L	5 - 8 gallons 19.0 - 30.3L
Diesel Tank	5 - 7 gallons 19.0 - 26.5L	7 - 10 gallons 26.5 - 38.0L	10 - 20 gallons 38.0 - 75.7L	20 - 30 gallons 75.7 - 113.5L
Hydraulic Tank	1 - 5 gallons 4.0 - 19.0L	5 - 10 gallons 19.0 - 38.0L	10 - 20 gallons 38.0 - 75.7 L	20 - 30 gallons 75.7 - 113.5L
Water Tank	up - 2 gallons up - 7.5L	2 - 4 gallons 7.5 - 15.0L	4 - 7 gallons 15.0 - 26.5L	7 - 10 gallons 26.5 - 38.0L

**CAUTION:** Do not use pads with higher than recommended wattage for specific oil capacities. For use on metal surfaces only.

## SECTION 5

---





# In-block Heaters

In-block heaters are complete with 2-wire w/ground 6' (1.8m) HPN cord and plug.  
For cord replacements or "Y" Thermocord energy saver, please reference page 48.



Engine Model	Part Number 120V	Part Number 240V	Watts	Application Information	Heat Shield Required	Photo
<b>Allis Chalmers</b>						
670T & I 685T & I 6138LT, T & I 25000 (844 CID)	AC-101 CATV-151	AC-102 CATV-152	1000 1500	Replaces 1" thread-in plug on the oil cooler at rear of the engine on right side. Not all of the engines have this opening.		
<b>Case/IH – Agricultural</b>						
ALL 4 CYL 390 ALL 6 CYL 590	CUB-751FP CUB-101FP CUB-151FP	CUB-752FP CUB-102FP CUB-152FP	750 1000 1500	Inserts in any of the core plugs on right side of engine.		
ALL 6 CYL 830	CUC-151FP	CUC-152FP	1500	Inserts in the core plug at right rear of engine block.		
<b>Caterpillar</b>						
C-10 C-12	TF121-000	TF122-000	1250	Replaces the threaded plug in the oil cooler bonnet on the right side of engine.	YES	
C-9 Non ACERT C-15 Non ACERT C-16 Non ACERT	CATV-151	CATV-152	1500	C-9: Replaces 1" NPT plug in the right rear of engine block. C-15, C-16: Replaces the threaded plug in the back of the oil cooler.		
C7 ACERT 3126	FP101-001 FP151-001	FP102-001 FP152-001	1000 1500	Replaces the 44mm core plug on right side of engine just below the turbo charger.	YES	
C7 ACERT rear port	TL101-000	TL102-000	1000	Replaces the threaded 1-1/16" (1.0625") plug in the rear of engine block.		
C9 ACERT	CATV-151	CATV-152	1500	Replace 1" NPT plug in the right rear of engine block.		
C11 ACERT C13 ACERT	TF151-008	TF152-008	1500	Replace any 1-5/16" (1.3125") plug in the rear of the oil cooler on right side of engine.	Check Exhaust Routing	
C15 ACERT w/o breaksaver	TF151-009	TF152-009	1500	Replace 1-3/16" (1.1875") plug in rear of oil cooler on right side of engine.		
C15 ACERT with breaksaver	TF151-008	TF152-008	1500	Replace any 1-5/16" (1.3125") plug in the oil cooler on right side of engine.		
C9 2007 ACERT C13 2007 ACERT C15 2007 ACERT	TF151-012	TF152-012	1500	Replace any 1-3/16" (1.1875") plug in rear of oil cooler on right side of engine.		
1674	CATB-151	CATB-152	1500	Replace the 1-1/2" (1.5") plug on right side of engine.		
1693 & D343	CATC-151	CATC-152	1500	Replaces the water jacket access plate on left side of engine.		
1693T & 1693TA	CATC-151-S	CATC-152-S	1500	Replaces the water jacket access plate on left side of engine.		
3013 1.5L 3014 2.0L	FP531-003	FP532-003	530	Replaces 40mm core plug on the front left side of engine.		



In-block heaters are complete with 2-wire w/ground 6' (1.8m) HPN cord and plug.  
For cord replacements or "Y" Thermocord energy saver, please reference page 48.



Engine Model	Part Number 120V	Part Number 240V	Watts	Application Information	Heat Shield Required	Photo
<b>Caterpillar — Continued</b>						
3024 2.22L	FP531-003	FP532-003	530	Replaces 40mm core plug on the front left side of the engine.		
3034 2.95L	FP531-001	FP532-001	530	Replaces 50mm core plug located at rear of head.		
3044 3.3L	PF531-001	PF532-001	530	Replaces the plate in oil cooler case on left side of engine.		
3046 5.0L	PF531-000	PF532-000	530	Replaces 35mm core plug located at rear of engine, left side.		
3054 3.99L 3054B 4.23L	PER-751FP PER-101FP	PER-752FP PER-102FP	750 1000	Mounts in the 1-1/4" (1.25") core plug opening on left side of engine.		
3054C	PER-751FP	PER-752FP	750	Mounts in 1-1/4" (1.25") core plug at right rear of engine with element oriented in the 12 O'clock position.		
3056 6.0L	PER-151FP	PER-152FP	1500	Mounts in the 1-1/2" (1.5") core plug on right side of engine.		
3114 3116	FP101-001 FP151-001	FP102-001 FP152-001	1000 1500	Replaces the 44mm core plug on right side of engine just below the turbocharger.	YES	
3176 10.3L through 1995	DD8L-101 CAT-12015 TF151-001	DD8L-102 CAT-12023 TF152-001	1000 1250 1500	Replaces the 3/4" (0.75") threaded plug on the right side of engine just below the head.		
3176 10.3L 1996 and later	TF121-000	TF122-000	1250	Replaces the 1" threaded plug in the oil cooler bonnet on right side of engine.	YES	
3196 12.0L	TF121-000	TF122-000	1250	Replaces the 1" threaded plug in oil cooler bonnet on right side of engine.	YES	
3204 all 1100 series	CATX-751 CATX-101	CATX-752 CATX-102	750 1000	Replaces 44mm core plug on right rear side of engine.		
3208 — 2 heaters with a single cord	CATX-2-751-Y	CATX-2-752-Y	1500 total	Use on industrial engines when clear access is available. Replaces any core plug - one on each side of engine.		
3208 Recommended aftermarket installation	JD3/4-101IN JD1-101IN JD3/4-151IN JD1-151IN	JD3/4-102IN JD1-102IN JD3/4-152IN JD1-152IN	1000 1000 1500 1500	Replaces any of the 3/4" (0.75") or 1" plugs on the water transfer casting (right front of engine). 3/4" use JD3/4 — 1" use JD1		
3304 3306	DD8L-101 CAT-12015 TF151-001	DD8L-102 CAT-12023 TF152-001	1000 1250 1500	Replaces the 3/4" (0.75") plug on left side of engine.		
3406C/E 14.6L	AC-101 CATV-151	AC-102 CATV-152	1000 1500	Replaces 1" threaded plug in the rear of the oil cooler bonnet on right side of engine.		

In-block heaters are complete with 2-wire w/ground 6' (1.8m) HPN cord and plug.  
For cord replacements or "Y" Thermocord energy saver, please reference page 48.



Engine Model	Part Number 120V	Part Number 240V	Watts	Application Information	Heat Shield Required	Photo
<b>Caterpillar — Continued</b>						
3406 & 3408 except 1998 ADEM 2	AC-101 CATV-151	AC-102 CATV-152	1000 1500	Replaces 1" threaded plug in the rear of the oil cooler bonnet on right side of engine.		
3406E 1998 ADEM 2 engines only	TF151-002	TF152-002	1500	Replaces the 1" threaded plug that points downward on the top of the rear of the oil cooler bonnet.	YES	
3406E ADEM 3 and ADEM 2000 engines	AC-101 CATV-151	AC-102 CATV-152	1000 1500	Replaces 1" threaded plug in the rear of the oil cooler bonnet on right side of engine.		
3456 15.8L	AC-101 CATV-151	AC-102 CATV-152	1000 1500	Replaces 1" threaded plug in the rear of the oil cooler bonnet on right side of engine.		
<b>Cummins</b>						
6 Cylinder Engines: H, NT, NH, N Family 743 CID, 855 CID, 927 CID, "N14"						
1. Cummins engines are often referred to by their horsepower rating "i.e. 350 Cummins"						
2. Cummins engines are often referred to as Big Cam, Big Cam2, 3, 4, full flow cooling, etc.						
<b>All refer to engines of 855 CID Size – listed below</b>						
<b>Group I</b>						
Flat plate design	CUN-151B	CUN-152B	1500	6 bolt flat plate on the right side of the engine. May use either the forward or rear opening depending on clearance.		
Flat plate design when the 1/2" NPT opening is used	CUN-151BH	CUN-152BH	1500			
<b>Group II</b>						
When an external oil cooler is used..		<b>Note:</b> When a 4 bolt flat plate element design is encountered, remove the next two bolts on the casting, remove the whole casting, and replace the casting and element with either CNT-151B/CNT-152B OR CNT151B90/CNT152B90				
When connection is 1 1/2" rubber hose Engines produced Aug. 1975 thru June 1982	CNT-151B-90	CNT-152B-90	1500	6 bolt, flat plate design with an elbow that will rotate 360 degrees to connect with any hose or casting.		
Uses an "O" ring for the 1 1/4" water tube connection Engines produced prior to August '75	CNT-151B	CNT-152B	1500	6 bolt, flat plate design with an elbow that will rotate 360 degrees to connect with any hose or casting.		
<b>Group III</b>						
For industrial engines with hole pattern reversed	CUN-151BREV	CUN-152BREV	1500	Six bolt flat plate on the right side of engine block.		
<b>Group IV</b>						
1998 and later N14 Industrial	PF151-002	PF152-002	1500	Six bolt flat plate on the right side of engine block.		

In-block heaters are complete with 2-wire w/ground 6' (1.8m) HPN cord and plug.  
For cord replacements or "Y" Thermocord energy saver, please reference page 48.



Engine Model	Part Number 120V	Part Number 240V	Watts	Application Information	Heat Shield Required	Photo
<b>Cummins — Continued</b>						
Cummins A 4 cyl & 6 cyl	CUA-101F	CUA-102F	1000	Inserts in any of the core plugs on right side of engine. Element points down.		
ISC/QSC 8.3L ISL/QSL 9.0L	DD8L-101 TF751-002	DD8L-102 TF752-002	1000 750	Replaces 3/4" (0.75") NPT plug in right front side of engine.		
L10, M11 ISM 2007	CUL-151	CUL-152	1500	Inserts in the forward opening of the heater casting on the right rear of engine block.		
QSB 3.9L, 5.9L ISB 5.9	TF751-002	TF752-002	750	Replaces 3/4" (0.75") NPT plug in the front of the oil cooler casting.		
ISM/QSM 11.0L Flat Plate Design	PF151-003	PF152-003	1500	Right rear. Replaces plate.		
ISX, QSX Signature 600 Pre 2007	PF151-004	PF152-004	1500	Mounts in the oval shaped plate on the right side of engine block.		
4BT 3.9L	CUB-751FP CUB-101FP	CUB-752FP CUB-102FP	750 1000	Replaces 57.8mm core plug on right side of engine.	Check Exhaust Routing	
6BT 5.9L	CUB-751FP CUB-101FP CUB-151FP	CUB-752FP CUB-102FP CUB-152FP	750 1000 1500	Replaces 57.8mm core plug on right side of engine.	Check Exhaust Routing	
6CT 8.3L	CUC-151FP	CUC-152FP	1500	Replaces 57.8mm core plug on right rear side of engine.		
<b>Detroit Diesel</b>						
SERIES 10 4 cylinder Phaser engines	PER-751FP PER-101FP	PER-752FP PER-102FP	750 1000	Mounts in the 1-1/4" (1.25") core plug opening on either side of engine.		
SERIES 10 6 cylinder Phaser engines	PER-151FP	PER-152FP	1500	Mounts in the 1-1/4" (1.25") core plug on right side of engine.		
SERIES 30	DD8L-101 TF751-002	DD8L-102 TF752-002	1000 750	Mounts in the 3/4" (0.75") NPT opening in engine block.		
SERIES 40 all versions	PER-751FP INTA-121 FR151-001	PER-752FP INTA-122 FR152-001	750 1250 1500	Mounts in the core plug opening on right side of engine.		

# In-block Heaters

In-block heaters are complete with 2-wire w/ground 6' (1.8m) HPN cord and plug.  
For cord replacements or "Y" Thermocord energy saver, please reference page 48.



Engine Model	Part Number 120V	Part Number 240V	Watts	Application Information	Heat Shield Required	Photo
<b>Detroit Diesel – continued</b>						
SERIES 50 SERIES 60 Pre 2007	AC-101 CATV-151	AC-102 CATV-152	1000 1500	Mounts in the 1" NPT opening in either water pick up pipe (up to 1991) or in the 1" NPT opening on the oil cooler housing after 1991.	Yes on 1991 and later	
SERIES 55	PF151-000	PF152-000	1500	Mounts in the triangle plate on the side of engine block.		
3-53, 4-53, 3-71, 4-71 with water cooled air compressor	DD-751-S	DD-752-S	750	Mounts in the oval shaped plate on engine block. Check clearance.		
3-53, 4-53, 3-71, 4-71 without water cooled air compressor	DD-751	DD-752	750	Mounts in the oval shaped plate on engine block. Check clearance.		
6-71 with water cooled air compressor	DD-151-S	DD-152-S	1500	Mounts in the oval shaped plate on engine block. Check clearance.		
6-71 without water cooled air compressor	DD-151	DD-152	1500	Mounts in the oval shaped plate on engine block. Check clearance.		
8.2 L V-8 Diesel	DD8L-101 TF751-002	DD8L-102 TF752-002	1000 750	Threads into the 3/4" (0.75") NPT opening on engine block.		
6V-53 with water cooled air compressor	DD6V-751-S	DD6V-752-S	750	Mounts in the oval shaped plate on engine block. Check clearance.		
6V-53 without water cooled air compressor	DD6V-751	DD6V-752	750	Mounts in the oval shaped plate on engine block. Check clearance.		
6V71 & 8V71 Alternate location	AC-101 CATV-151	AC-102 CATV-152	1000 1500	Threads into 1" NPT plug in the front face of engine block.		
6V-71 & 8V-71 6V-92 & 8V-92 except GMC General models	DDV-151B	DDV-152B	1500	Mounts in the square plate on engine block.		
6V92 & 8V92 alternate location - threads into oil cooler	DD8L-101 TF751-002	DD8L-102 TF752-002	1000 750	Threads into the 3/4" (0.75") NPT opening in the oil cooler housing. Note - not all engines have this opening.		
<b>Deutz</b>						
BF4L913 BF6L913 F3L912 F3L913 F6L913  1011 SERIES oil cooled engines	OLT221515 and A22M48M (adapter)	n/a	150	Use adapter kit to mount the 22mm heater in the 48mm opening.		

In-block heaters are complete with 2-wire w/ground 6' (1.8m) HPN cord and plug.  
For cord replacements or "Y" Thermocord energy saver, please reference page 48.



Engine Model	Part Number 120V	Part Number 240V	Watts	Application Information	Heat Shield Required	Photo
<b>Deutz – continued</b>						
1012 — 4 & 6 cyl 1013 — 4 cyl	PF751-000 PF121-001	PF752-000 PF122-001	750 1250	Mounts in the oval shaped plate opening on the oil cooler casting.		
1013 6 cyl	PF121-001 PF751-000	PF122-001 PF752-000	1250 750	Mounts in the oval shaped plate opening on the top of the oil cooler.		
1015 6 & 8 cyl	TL151-004	TL152-004	1500	Replaces 30mm plug in water elbow on front of engine.		
2012 — 4 & 6 cyl without electric fuel injection	PF751-002	PF752-002	750	Replace oval shaped plate on the top of the oil cooler.		
<b>Ford</b>						
7.3L V-8 diesels from 1994 on	TF751-002 DD8L-101	TF752-002 DD8L-102	750 1000	Mounts in the 3/4" (0.75") NPT plug in the engine's block.		
<b>Hino</b>						
3.8L, 5.8L, 6.0L, 6.4L, 6.7L, H06C-T, H07C-B, W04C-T, W06E	DD8L-101 TF751-002	DD8L-102 TF752-002	1000 750	Threads into 3/4" (0.75") NPT opening in engine block.	YES	
<b>Isuzu</b>						
4BD1 6HE1 6BD1 6SA1 6BG1	TF401-001	NONE	400	Replaces 1" NPT plug on left rear of engine.		
<b>Iveco</b>						
NEF 4 cyl NEF 6 cyl	PF751-001	PF752-001	750	Mount in front opening on right side of engine block.		
<b>John Deere</b>						
With 3/4" plug in the back of the block	JD3/4-101IN JD3/4-151IN	JD3/4-102IN JD3/4-152IN	1000 1500	3/4" (0.75") NPT opening in the rear face of engine block.	Check Exhaust Routing	
With 1" plug in the back of the block	JD1-101IN JD1-151IN	JD1-102IN JD1-152IN	1000 1500	1" NPT opening in the rear face of engine block.		
With 1-5/8" opening on the side of the water jacket	JDS-101 JDS-151	JDS-102 JDS-152	1000 1500	1-5/8" (1.625") threaded opening on the side of the block in the water distribution channel.		

# In-block Heaters

In-block heaters are complete with 2-wire w/ground 6' (1.8m) HPN cord and plug.  
For cord replacements or "Y" Thermocord energy saver, please reference page 48.



Engine Model	Part Number 120V	Part Number 240V	Watts	Application Information	Heat Shield Required	Photo
<b>John Deere – continued</b>						
6105 (10.5L) 6125 (12.5L)	AC-101 CATV-151	AC-102 CATV-152	1000 1500	1" NPT opening in the oil cooler casting.		
<b>Komatsu</b>						
L10 (10L) M11(11L)	CUL-151	CUL-152	1500	Inserts in the forward opening of the heater casting on the right rear of engine block.		
SA6D125	MA-151	MA-152	1500	Threads into the core plug opening in engine block.		
<b>Kubota</b>						
B, L, M Series D905 V1205 D1005 V1305 D1105 V1505 D3000B V4000B D3200B V4300B DH905 VH1205 DH1005 VH1305	TF401-001	NONE	400	Replaces 1" NPT plug on left front of engine.		
<b>Mack</b>						
Mid liner E3 MS200 & MS250	MAM-101	MAM-102	1000	Mounts in rear face of block.		
Mid liner E5 MS300	MAM-151	MAM-152	1500	Mounts in the oil cooler bonnet.		
E6 engines "smooth bore" 1981 and later	MASB-151	MASB-152	1500	Replaces 1-3/4" (1.75") core plug on side of engine.		
E6 engines threaded core plug opening Pre-1981 END 465, 711, EN438, 504, 707, 673, 675, 676 (1957 through 1981)	MA-151	MA-152	1500	Mounts in any threaded core plug opening.		
E7 Engines Except E-Tech water pump mount	PF151-001 PF101-000	PF152-001 PF102-000	1500 1000	Mounts in the plate in either the front or rear face of the block in the water jacket passage. For 2002 engine – mounts in rear face of block.		
E9, ENDT865, 866 and 1000 series V8 engines Use two heaters	DD8L-101	DD8L-102	2000 total	Threads into the 3/4" (0.75") NPT opening on each side of engine block.		



In-block heaters are complete with 2-wire w/ground 6' (1.8m) HPN cord and plug.  
For cord replacements or "Y" Thermocord energy saver, please reference page 48.



Engine Model	Part Number 120V	Part Number 240V	Watts	Application Information	Heat Shield Required	Photo
<b>MAN</b>						
D2840 D2842 D2848	PF121-003	PF122-003	1250	Replace oval shaped plate in lower water pipe on right side of engine.		
D2866 D2876	PF151-006	PF152-006	1500	Replace 3 bolt plate on left side of engine. May require adapter if 3 bolt opening is not available on engine. Consult customer service.		
<b>Massey Ferguson</b>						
3 cylinder 4 cylinder 6 cylinder	PER-751FP PER-101FP	PER-752FP PER-102FP	750 1000	Mounts in any of the 1-1/4" (1.25") core plug openings in the engine.	YES	
<b>Mercedes Benz</b>						
MBE904 MBE906 MBE924 MBE925	PF101-001	PF102-001	1000	Replaces 60mm core plug on right rear of engine.		
<b>Navistar/International</b>						
V800 (796 CID)	AC-101 CATV-151	AC-102 CATV-152	1000 1500	Threads into a 1" NPT opening in the oil cooler bonnet.		
INLINE 6 CYLINDER — all series — 312, 360, 414, 436, 466 & 530	INTA-121 INTA-101	INTA-122 INTA-102	1250 1000	Replaces third or fourth core plug on left side of engine. Element should point toward 1 O'clock position.		
7.3L & T444 1994 and later	TF751-002 DD8L-101	TF752-002 DD8L-102	750 1000	Mounts in the 3/4" (0.75") NPT plug in the engine's block.		
9.0L — V8 diesel	INT9-101F	INT9-102F	1000	Mounts in a core plug.		
<b>Oliver</b>						
ALL EXCEPT 1265, 1365 & 1900	TF751-002 DD8L-101	TF752-002 DD8L-102	750 1000	Threads into a 3/4" (0.75") NPT opening in the block.		
<b>Onan — See Cummins "A" Series</b>						
<b>Perkins</b>						
3.152 4.236 6.354	PER-751FP PER-101FP	PER-752FP PER-102FP	750 1000	Mounts in the 1-1/4" (1.25") core plug opening on right side of engine.		
103.15 104.22 404.22	FP531-003	FP532-003	530	Replaces core plug on left front of engine.		

## In-block Heaters

In-block heaters are complete with 2-wire w/ground 6' (1.8m) HPN cord and plug.  
For cord replacements or "Y" Thermocord energy saver, please reference page 48.



Engine Model	Part Number 120V	Part Number 240V	Watts	Application Information	Heat Shield Required	Photo
<b>Perkins – continued</b>						
700 Series 704.30	FP531-001	FP532-001	530	Replaces 50mm core plug located at rear of head.		
800 Series	PF531-001	PF532-001	530	Mounts in oval shaped plate on the left front of the block.		
1004 (right side)	FR751-002 FR101-000 PER-151FP	FR752-002 FR102-000 PER-152FP	750 1000 1500	Mounts in the 1-1/2" (1.5") core plug opening on right side of engine.		
1004 (left side)	PER-751FP PER-101FP	PER-752FP PER-102FP	750 1000	Mounts in the 1-1/4" (1.25") core plug opening on left side of engine.		
1006 (6 Cyl) A & B	PER-151FP	PER-152FP	1500	Mounts in the 1-1/2" (1.5") core plug on right side of engine.		
1103C	FR531-000- WOC	FR532-000- WOC	530	Replaces 1-1/4" (1.25") core plug on right rear of engine. Element should point towards 1 O'clock position.		
1104 (4 Cyl) C & D	PER-751FP PER-101FP	PER-752FP PER-102FP	750 1000	Mounts in 1-1/4" (1.25") core plug opening on right side of engine.		
2506 2508	CATV-151	CATV-152	1500	Mounts in 1" NPT at right rear of engine		
<b>Volvo</b>						
D9	PF151-007	PF152-007	1500	Replaces oval shaped plate on right side of engine.		
D12C Prior to Serial #250502	PF151-005	PF152-005	1500	Replaces oval shaped plate on right side of engine.	YES	
D12C After Serial #250502	PF121-002	PF122-002	1250	Replaces oval shaped plate on right side of engine.	YES	
TD60, TD61, TD70, TD71, TD100, TD101, VE10, TD120, TD121	VT6-101	VT6-102	1000	Mounts into threaded opening on left side of engine.		
<b>Yanmar</b>						
3T72HLE 4TN82E D4T YYDXL4.41	TF401-001	NONE	400	1" NPT No replacement cord available.		

**NOTE:** The only replacement part for in-block heaters is the power cord. Please see the power cord section on page 48 for the proper replacement cord set. For thermostat control of in-block heaters, see page 48. The energy saver Thermocord is available in various temperature ranges. Supplemental heat for engines using in-block heaters can be achieved by the installation of lube-oil heaters in the oil pan. Reference pages 20 and 21 of this catalog or consult factory.

Instructions for:  
In-block heaters  
Please refer to specific instructions that accompany heater.

### THREADED PLUG TYPE HEATERS



- Drain the cooling system.
- Remove the recommended core plug. (See instructions with heater)
- Apply teflon tape to pipe threads or grease to O-ring.
- Thread heater into engine.

**Please follow these steps to ensure proper operation of your HOTSTART in-block heater.**

- Align cord with pins on the heater and press the cord into the heater. Place clamp around cord & heater. **DO NOT PLUG IN HEATER YET!**
- Route the cord, keeping away from hot or moving surfaces.
- Re-fill the cooling system. Run engine until engine thermostat opens and continue running for another 20 minutes to eliminate air.
- Stop engine and let cool. Check for leaks. Check coolant level.
- Plug heater into power supply and test for proper operation. Block should feel warm near heater.

### PLATE TYPE HEATERS



- Drain the cooling system.
- Remove the recommended plate. (See instructions with heater)
- Clean the gasket area.
- Apply gasket sealant to plate and engine surfaces.
- Insert heater into engine. Tighten bolts.

**Please follow these steps to ensure proper operation of your HOTSTART in-block heater.**

- Align cord with pins on the heater and press the cord into the heater. Place clamp around cord & heater. **DO NOT PLUG IN HEATER YET!**
- Route the cord, keeping away from hot or moving surfaces.
- Re-fill the cooling system. Run engine until engine thermostat opens and continue running for another 20 minutes to eliminate air.
- Stop engine and let cool. Check for leaks. Check coolant level.
- Plug heater into power supply and test for proper operation. Block should feel warm near heater.

### FREEZE (CORE) PLUG TYPE HEATERS



- Drain the cooling system.
- Remove the recommended core plug. (See instructions with heater)
- Clean, smooth and dry core plug opening.
- If retaining ring style, apply a light coat of grease to the O-ring and core plug opening. If press-in style, apply a light coat of high-temperature, high-strength retaining compound (Loctite 640 recommended).
- Insert heater into engine and position properly. Push the heater into the engine by hand, then tap in using a suitable tool until flange is even with engine block.

**Please follow these steps to ensure proper operation of your HOTSTART in-block heater.**

- Align cord with pins on the heater and press the cord into the heater. Place clamp around cord & heater. **DO NOT PLUG IN HEATER YET!**
- Route the cord, keeping away from hot or moving surfaces.
- Re-fill the cooling system. Run engine until engine thermostat opens and continue running for another 20 minutes to eliminate air.
- Stop engine and let cool. Check for leaks. Check coolant level.
- Plug heater into power supply and test for proper operation. Block should feel warm near heater.

# Replacement Cords & Thermostats

## Heat Shield

HS1



Use when exhaust manifold or turbo come close to heater termination.

## TwinStat™ Thermocord

HOTSTART's TwinStat™ Thermocord is an energy efficient, idle reduction heater cord ideal for fleet operations. The cord's twin thermostats monitor engine temp and ambient temp, allowing for heating to happen only when needed. Contact HOTSTART customer service to select the best heater cord for your fleet.



**NOTE:** When ordering in-block heater **and** thermocord, place suffix **-WOC** (which stands for **without cord**) after the heater model number to save cost as the standard 6' (1.8m) heater cord is replaced by the Thermocord harness.

## For use with In-block Heaters

Cord Length	Plug Style	120 Volt	240 Volt
6' 1.8m	1	IM6-1IN	IM6-2IN
11' 3.4m	1	IM11-1IN	IM11-2IN
16' 4.8m	1	IM16-1IN	IM16-2IN
Cord Length	Plug Style	120 Volt	240 Volt
6' 1.8m	2	11PR72T	21PR72T
11' 3.4m	2	11PR132T	21PR132T
16' 4.8m	2	11PR192T	21PR192T

### STYLE 1



15amp, 120V



15amp, 240V

Fits most competitor's applications.

### STYLE 2

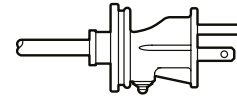

15amp, 120V

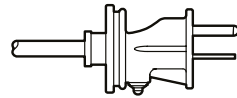

15amp, 240V



## Thermocord for In-block Heaters

Part No.	Volts	Thread Size	Temp Range
TC031308-866	120	1/2"	80°-100°F (27°-38°C)
TC031310-866	120	1/2"	100°-120°F (38°-49°C)
TC031312-866	120	1/2"	120°-140°F (49°-60°C)
TC032308-866	240	1/2"	80°-100°F (27°-38°C)
TC032310-866	240	1/2"	100°-120°F (38°-49°C)
TC032312-866	240	1/2"	120°-140°F (49°-60°C)

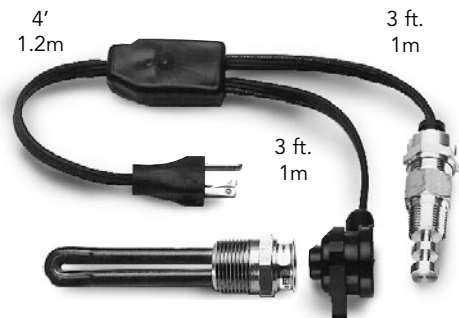

Heater shown for illustration purposes only



## Flush Mount Kits for In-block Heaters

Model Number 120 Volt	Model Number 240 Volt	Cord Length	Plug Style
IM6-1IN-FM	IM6-2IN-FM	6' (1.8m)	2
IM11-1IN-FM	IM11-2IN-FM	11' (3.4m)	2
IM16-1IN-FM	IM16-2IN-FM	16' (4.8m)	2

Kits include:  
11PR- style  
cord (shown  
on page 48),  
recessed male  
receptacle and  
hinged flip  
cover.

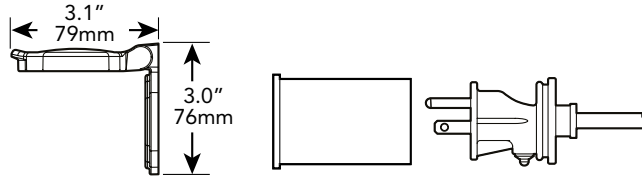

## Flush Mount Kits for Thermosiphon Engine Heaters

Model Number	Volts	Amps	For Heater with Wattage of:
FM15120	120	15	500 to 1800
FM15240	240	15	500 to 3000
FM20120	120	20	2000 to 2250

Kits include:  
Recessed male  
receptacle with 6'  
(1.8m) cord (no female  
connectors), hinged  
flip cover and female  
connector.

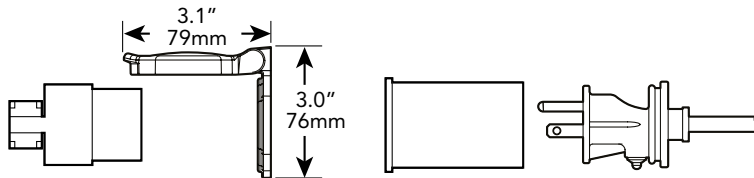

## Other Accessories

### Recessed Male Receptacle – with 6' (1.8m) cord (no female connectors)

Model Number	Volts	Amps
RM5-15	120	15
RM6-15	240	15
RM5-2Ø	120	20
RM6-2Ø	240	20

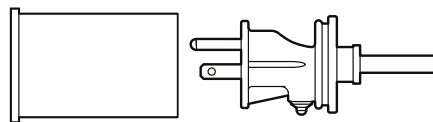

### Female Connector - for extension cords

Model Number	Volts	Amps
FM1G2ØA	120	15/20
FM2G2ØA	240	15/20

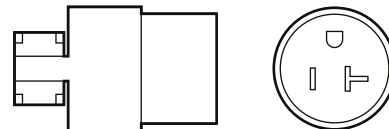

### Hinged Flip Cover

Model Number	Description
*FC-KH	Black/HOTSTART Logo
FC-KH-C	Chrome/HOTSTART Logo

\*Standard with kit

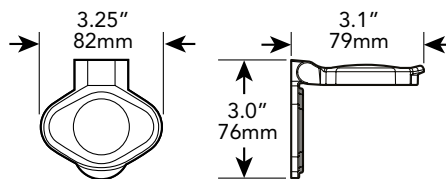

### Plug Housing

Model Number
A-2223-PH

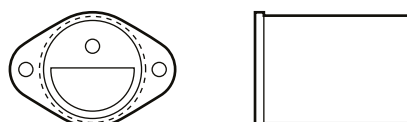

# Specifying an Engine Heater

1. Determine the best type of heater to be used for the application.
  - In-block or Thermosiphon Engine Heater?
  - Weathertight model for all indoor or outdoor applications (hospital, communications building, shopping mall, pump station, off-road equipment).
  - Hazardous Location model (off-shore platform, oil rig, gas compression station).
2. Determine engine size.
  - Cubic inch or liter displacement.
3. Determine wattage required by using this general formula:
  - 3 watts x cubic inch displacement = watts required.  
Example: Engine is 855 CID. Requirement is 2500 watt heater. (855 x 3 = 2565)
  - This formula is a very good rule of thumb to use down to 0°F (-18°C) ambient temperature. This formula will generally hold engine temperature at approximately 100°F (38°C) above ambient.
  - Engines over 1250 CID (20 L) and V-type engines require forced circulation preheating systems (CTM, CKM, CSM models — see pages 4-6).
4. Now that you have the required wattage, you need to determine:
  - Voltage available that will power the heater (120, 208, 277, 240, 380, 480, etc.).
  - Is the power source Single Phase or Three Phase?
5. For thermostat selection, determine the desired engine temperature to be maintained.
  - 100°F (38°C) to 120°F (49°C) applies 95% of the time. However, specifications vary with respect to the user and a higher or lower range may be required.

You now have the specifications needed to select the required engine preheater from the many products listed in this catalog. For other technical information and installation tips, see pages 18 and 47. If you have other questions or need additional assistance, please contact our customer service department.

## Conversion Factors

- Liters x 1.0567 = Quarts
- Quarts x 0.94635 = Liters
- Liters x 0.26417 = Gallons
- Gallons x 3.7854 = Liters

## Cubic Inches - Liters Conversion Chart

Cubic Inches	Liters	Cubic Inches	Liters	Cubic Inches	Liters
150	2.46	1600	26.22	3050	49.98
200	3.28	1650	27.04	3100	50.80
250	4.10	1700	27.86	3150	51.62
300	4.92	1750	28.68	3200	52.44
350	5.74	1800	29.50	3250	53.26
400	6.55	1850	30.32	3300	54.08
450	7.37	1900	31.13	3350	54.90
500	8.19	1950	31.95	3400	55.71
550	9.01	2000	32.77	3450	56.53
600	9.83	2050	33.59	3500	57.35
650	10.65	2100	34.41	3550	58.17
700	11.47	2150	35.23	3600	58.99
750	12.29	2200	36.05	3650	59.81
800	13.11	2250	36.87	3700	60.63
850	13.93	2300	37.69	3750	61.45
900	14.75	2350	38.51	3800	62.27
950	15.57	2400	39.33	3850	63.09
1000	16.39	2450	40.15	3900	63.91
1050	17.21	2500	40.97	3950	64.73
1100	18.03	2550	41.79	4000	65.55
1150	18.84	2600	42.61	4050	66.37
1200	19.66	2650	43.42	4100	67.19
1250	20.48	2700	44.24	4150	68.00
1300	21.30	2750	45.06	4200	68.82
1350	22.12	2800	45.88	4250	69.64
1400	22.94	2850	46.70	4300	70.46
1450	23.76	2900	47.52	4350	71.28
1500	24.58	2950	48.34	4400	72.10
1550	25.40	3000	49.16	4450	72.92

## Temperature

Fahrenheit	Celsius
-40°F	-40°C
-30°F	-34°C
-20°F	-29°C
-10°F	-23°C
0°F	-18°C
10°F	-12°C
20°F	-7°C
30°F	-1°C
40°F	4.5°C
50°F	10.0°C
60°F	15.5°C
70°F	21.0°C
80°F	27.0°C
90°F	32.0°C
100°F	38.0°C
110°F	43.0°C
120°F	49.0°C
130°F	54.0°C
140°F	60.0°C
150°F	65.5°C
160°F	71.0°C
170°F	77.0°C
180°F	82.0°C
190°F	88.0°C
200°F	93.0°C
210°F	99.0°C

C x 1.8 + 32 = °F  
 (F - 32) x 0.55 = °C

Cubic Inches x 0.01639 = Liters  
 Liters x 61.024 = Cubic Inches



HOTSTART forced circulation preheating systems are ideal for engines ranging in size from 10 L to the largest displacement currently in production. These systems are designed specifically for installation on a generator, compressor package, marine engine or locomotive. HOTSTART offers forced circulation heating systems for coolant heating, lube oil heating and diesel fuel heating. Combination systems are also available that heat and circulate coolant and oil in one pre-assembled unit. Complete with all necessary components and controls, these automated systems are available in various wattage, voltage and phase combinations to accommodate most large industrial preheating needs.

For additional information regarding HOTSTART's forced circulation heating systems, please visit [www.hotstart.com](http://www.hotstart.com) or contact HOTSTART and have all your questions answered by one of our engine heating product specialists.

### CMM/CLM Models



### Coolant-only Heating Systems

Voltage Range: 230–690 V  
Heat Power: 6–144 kW

### CLE/CLA Models



Coolant heating systems are designed to heat and circulate coolant throughout the engine's cooling system to efficiently maintain an engine at optimum starting temperatures. Maintaining jacket water temperatures ensures easy starting, reduces harmful emissions at start-up and allows engines to go to full power without needless idling.

### OSM Model



### Oil-only Heating Systems

Voltage Range: 120–690 V  
Heat Power: 1–48 kW

### OLE/OLA Models



Oil heating systems provide uniform heating to the oil throughout the engine oil sump and external piping, enhancing engine or compressor availability and decreasing wear and tear from cold startups.

### Auxiliary Power Unit for Locomotive Engines



The HOTSTART APU allows an idling locomotive to be shut down in cold weather at any location. This self-contained system runs off the locomotive's fuel supply. It will maintain water temperature at 100°F (38°C) above ambient and provides cab heat.

### Coolant and Oil Heating Systems OCLE/OCLA Models

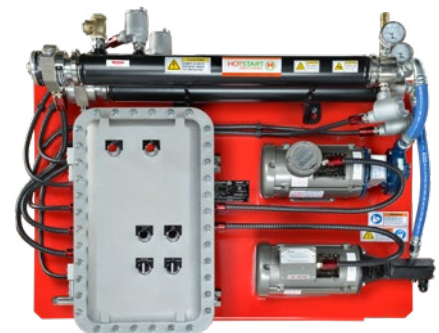

Voltage Range: 230–600 V  
Heat Power (Oil): 2.5–12 kW  
Heat Power (Coolant): 6–36 kW

**Corporate and Manufacturing Headquarters**

5723 E Alki Ave  
Spokane, WA 99212  
USA  
509.534.6171  
sales@hotstart.com

**Oil & Gas/Marine Office**

21732 Provincial Blvd  
Suite 170  
Katy, TX 77450  
USA  
281.600.3700  
oil.gas@hotstart.com  
marine@hotstart.com

**Railroad Office**

8915 Broadway  
Merrillville, IN 46410  
USA  
219.648.2448  
railroad@hotstart.com

**United Kingdom Office**

HOTSTART Birmingham Ltd.  
Cygnus Way  
West Bromwich  
West Midlands  
B70 0XB  
United Kingdom  
+44 0121 511 0440  
uk@hotstart.com

**Europe Office**

HOTSTART Europe GmbH  
Hansestraße 79  
51149 Köln  
Germany  
+49.2203.98137.30  
europe@hotstart.com

**Asia Pacific Office**

HOTSTART Asia Pacific Ltd  
2-27-15-4F, Honkomagome  
Bunkyo-ku, Tokyo  
113-0021, Japan  
+81.3.6902.0551  
apac@hotstart.com

## Customer Service



To better serve you, HOTSTART provides a customer service department to answer all your engine heating concerns and questions or to take your sales order.

Customer Service Department:  
509.536.8660

Sales orders and requests for quotes can also be faxed to our toll-free FAX line.

Toll-free FAX line: 800.224.5550

## Warranty Information

The warranty below has been drafted to comply with the Federal Law applicable to products manufactured after December 31, 1976. This warranty gives you specific legal rights, and you may also have other rights which vary from state to state.

HOTSTART products are warranted against defects in workmanship and materials. No other express warranty, written or oral, applies. No person is authorized to give any other warranty or assume any liability except by written statement from an officer of HOTSTART, Inc.

The warranty extends for twelve months from date of shipment from factory or authorized distributor.

Products must be installed and maintained in accordance with HOTSTART, Inc. instructions. Users are responsible for the suitability of the products to their application. There is no warranty against damage resulting from corrosion, misapplication, improper specification or other operating conditions beyond our control. Claims against carriers for damage in transit must be filed by the buyer.

Absolutely no material can be returned to HOTSTART, Inc. without prior factory authorization.

Upon factory authorization, return the defective part or product, freight prepaid, to: HOTSTART, 5723 E Alki Ave, Spokane, WA 99212.

Defective items will be repaired or replaced, at our option, at no charge. Such repair or replacement is the exclusive right of HOTSTART, Inc. HOTSTART, Inc. is not liable for labor costs incurred in removal, reinstallation, or unauthorized repair of the product or for damage of any type whatsoever including incidental or consequential damage. Some states do not allow the exclusion or limitation of incidental or consequential damages, so the preceding limitation or exclusion may not apply to you.

Exports, re-exports and imports of HOTSTART products are subject to U.S. export controls. If you are an exporter, importer, distributor, customer or end-user, you are responsible for complying with U.S. export controls and any local export laws in your jurisdiction. We encourage you to seek appropriate legal advice before you export, re-export or sell HOTSTART products.

For more information on exporting products under the U.S. Export Administration Regulations (EAR), please visit the Bureau of Industry and Security (BIS) website: <http://www.bis.doc.gov>

HOTSTART, Inc.



Distributor