

SAFETY MARKING & IDENTIFICATION PRODUCTS



Customer Built Since 1975

SAFETY TAPES

GATOR GRIP® PREMIUM GRADE ANTI-SLIP TAPE	8
MILITARY & MARINE GRADE ANTI-SLIP TAPE	8
GRIT TAPE APPLICATOR ROLLER.....	8
GATOR GRIP® PREMIUM GRADE COLORED ANTI-SLIP TAPE	9
GATOR GRIP® PREMIUM GRADE ANTI-SLIP CLEATS	9
GATOR GRIP® PREMIUM GRADE 'WATCH YOUR STEP' ANTI-SLIP TAPE ...	10
GATOR GRIP® STADIUM TRACK "HIGH VISIBILITY" ANTI-SLIP TAPE	10
GATOR GRIP® PREMIUM GRADE ANTI-SLIP FOOTPRINTS.....	10
GATOR GRIP® HEAVY DUTY (36-GRIT) ANTI-SLIP TAPE	11
GATOR GRIP® SUPER COARSE XP (24-GRIT) ANTI-SLIP TAPE	11
GATOR GRIP® FOIL BACKED ANTI-SLIP TAPE	12
GATOR GRIP® PHOTOLUMINESCENT ANTI-SLIP TAPE.....	12
GATOR GRIP® MOP FRIENDLY SLIP-RESISTANT TAPE	13
GATOR GRIP® EMBOSSED COARSE RESILIENT SLIP-RESISTANT TAPE	13
aisle MARKING CONFORMABLE TAPE	16
HAZARD WARNING TAPE	17
CHECKERBOARD LAMINATED TAPE	17
aisle TAPE DISPENSER.....	17
CLEAR SELF LAMINATION TAPE	17
TUFFMARK® ULTRA DURABLE FLOOR MARKING TAPE	18
ARMADILLO® DURABLE FLOOR TAPE	18
COLORED ARROWS & DOTS	19
SAFETY MESSAGE FLOOR TAPE	19
5S/LEAN WORKPLACE ORGANIZATION MARKERS.....	22-23
5S SHADOW BOARD STORAGE ORGANIZERS	24-25
GATOR GRIP® GLOW-IN-THE-DARK ANTI-SLIP TAPE	28
ARROWS & DOTS GLOW-IN-THE-DARK MARKING	28
DIRECTIONAL FIRE EXIT GLOW-IN-THE-DARK TAPE	29
HAZARD & SAFETY GLOW-IN-THE-DARK TAPE	29
PRIME GUARD BARRICADE TAPE	32-35
ENGINEER GRADE REFLECTIVE TAPE	38
SUPERBRITE HIGH INTENSITY REFLECTIVE TAPE	39
NEONBRITE FLUORESCENT REFLECTIVE TAPE.....	39
CONSPICUITY DOT-C2 REFLECTIVE TAPE.....	40
SCHOOL BUS YELLOW CONSPICUITY REFLECTIVE TAPE	40
REFLEX REFLECTIVE STICK-ON REFLECTORS	40
REFLECTIVE KIT HARD HAT DECALS	41

SAFETY SIGNS, TAGS & LABELS

PIPE MARKING.....	44-49
ABATEMENT SIGNS, TAGS, TAPES & LABELS	50-53
DANGER SAFETY SIGNS	56-61
WARNING SAFETY SIGNS	62-63
CAUTION SAFETY SIGNS	64-66
NOTICE SAFETY SIGNS.....	67-69
SAFETY FIRST & HOUSE KEEPING SIGNS.....	70-71
BILINGUAL SAFETY SIGNS ENGLISH/SPANISH.....	72
SAFETY SIGNS SPANISH.....	73
BILINGUAL SAFETY SIGNS ENGLISH/FRENCH.....	74
SAFETY SIGNS FRENCH.....	75
ANSI SAFETY SIGNS.....	76-78
CSA SAFETY SIGNS.....	79-81
ISO INTERNATIONAL SAFETY SIGNS	82
FACILITY & PARKING SIGNS.....	83
FIRE SAFETY & EMERGENCY SIGNS	84-85
SAFETY FLOOR SIGNS.....	86-90
A-FRAME STANDING FLOOR SIGNS	91
GENERAL INFORMATION SIGNS	92-93
DANGER WORKPLACE TAGS	96-99
WARNING WORKPLACE TAGS	100-101
CAUTION WORKPLACE TAGS	102-103
NOTICE WORKPLACE TAGS	104
SELF LAMINATING TAGS	105
LOCKOUT (LOTO) TAGS	106-107
BILINGUAL SAFETY TAGS ENGLISH/SPANISH	108-109
BILINGUAL SAFETY TAGS ENGLISH/FRENCH	110-111
TAGS-ON-A-ROLL.....	112-113
INSPECTION TAGS.....	114-115

TRANSPORTATION OF DANGEROUS GOODS

DOT WORDED TRUCK PLACARDS (USA VERSION)	118-119
DOT UN TRUCK PLACARDS (USA VERSION)	120-121
PLACARD NUMBERS & NUMBER KITS	120
DOT PRE-NUMBERED TRUCK PLACARDS (USA VERSION)	122-123
DOT WORDED SHIPPING LABELS (USA VERSION).....	124
DOT WORDED TABBED SHIPPING LABELS (USA VERSION)	125
TDG TRUCK PLACARDS (CANADA & INTERNATIONAL)	128-129
TDG UN TRUCK PLACARDS (CANADA & INTERNATIONAL).....	130-131
TDG PRE-NUMBERED TRUCK PLACARDS (CANADA & INTERNATIONAL)	132-133
TDG SHIPPING LABELS (CANADA & INTERNATIONAL).....	134
TDG Tabbed Shipping Labels (Canada & International)	135
FUEL TAG DIAL STAINLESS STEEL.....	135
PLACARD HOLDER	136
EASY ACCESS ALUMINUM PLACARD HOLDER WITH SHIELD	136
HEAVY DUTY PLACARD HOLDER	136
SPLIT PLACARD HOLDER	137
CLIPPED CORNER PLACARD HOLDER	137
PLACARD HOLDER FACE PLATES.....	137
PROTECTIVE SHIELD	137
DOT WORDED TRUCK FLIP PLACARDS (USA VERSION).....	138-139
TDG TRUCK FLIP PLACARDS (CANADA & INTERNATIONAL).....	140-141
FLIP PLACARD CLIP	140
PLACARD HOLDER CLIP	140
FUEL FLIP PLACARDS (USA, CANADA & INTERNATIONAL)	142-143
FLIP PLACARD WITH ROTATING NUMBERS	144
RIGID-FLIP RECTANGLE PAGE FLIP PLACARD	145
VEHICLE SAFETY DECALS.....	146
SPECIALITY HANDLING LABELS	146
TRANSPORT TRAILER SAFETY SIGNS	147
INVENTORY CODING LABELS	147
SECURITY SEALS	148-149
NFPA HAZARDOUS MATERIAL SIGNS	152
NFPA 704 DIAMOND	153
NFPA WALLET GUIDE	154
NFPA LABEL ROLLS	154
NFPA HAZARDOUS MATERIAL TAGS.....	155
NFPA FLIP PLACARD	155

HazCom 2012/WHMIS 2015

INFORMATION WALL CHART	158
PICTOGRAM WALL CHART.....	158
SIMPLIFIED PICTOGRAM WALL CHART	158
SAFETY DATA SHEET INFORMATION STATION	159
SAFETY DATA SHEET STATION	159
SAFETY DATA SHEET BINDERS	159
SAFETY DATA SHEET AWARENESS DECALS.....	160
METAL SAFETY DATA SHEET STORAGE CASE	160
GHS TRAINED STICKERS	160
INFORMATION DECALS	160
SECONDARY WORKPLACE TAGS & LABELS	161
MAKE YOUR OWN WORKPLACE TAGS	161
PICTOGRAM LABELS.....	162
GHS HAZARD CLASS & PPE PICTOGRAM LABELS.....	163
HAZARD PICTOGRAM VARIETY PACK	163
SIGNAL WORD SIGNS.....	163
SAFETY DATA SHEET POCKET BOOKLET	164
WALLET CARDS.....	164
MAKE YOUR OWN LASER LABELS.....	165
MAKE YOUR OWN THERMAL TRANSFER LABELS	165
SUPPLIER LASER LABELS.....	165

STORE DISPLAYS

ANTI-SLIP & REFLECTIVE DISPLAY MERCHANDISERS.....	166-167
SAFETY IDENTIFICATION DISPLAY MERCHANDISERS.....	168-169

SIGN AUDIT TOOL

SIGN REQUIREMENT CHECK LIST.....	171
----------------------------------	-----

Feature Products

5S Shadow Board Storage Organizers
Page 24-25



A-Frame Standing Floor Signs
Page 91



NFPA 704 Hazard Rating Diamond
Page 150-155



Dangerous Goods Truck Placards
Page 116-145



Safety Signs
Page 54-93



Safety Tags
Page 94-115



1 Anti-Slip Tapes

Offer added protection from Slip, Trip and Fall incidents. A wide variety of grades and materials exist to perfectly suit your application needs.

Product applications:

- Stair treads, steps and platforms
- Wet or oily areas
- Transition areas from one floor surface to another
- Floor markings to denote hazards
- Indoor or outdoor slip hazards
- Tow motors, cherry pickers, construction or other equipment
- Loading docks
- Shower areas
- Catwalks
- Ladders
- Scaffolds

2 Floor Marking Tapes

Are an effective and easy solution for workflow and organization in your Facility.

Product applications:

- Forklift traffic marking
- Fire Aisle marking
- Storage area marking
- Fire equipment area marking
- Machine boundaries
- Hazard areas
- Marking locations of first aid and safety equipment
- General workflow

3 Reflective Tapes

Offer increased visibility in daytime and nighttime applications. Available in a variety of grades to suit any application.

Product applications:

- Property and gate markers
- Equipment
- Tow motors and forklifts
- Bollard and railing markings
- Trailers
- Beams and posts
- Fleet vehicle markings
- Entrances and exits
- Loading docks
- Low hanging hazards

4 Glow-in-the-dark Tapes

Are an essential part of escape route planning. These tapes remain visible in the dark for extended periods of time without use of a power supply and will clearly mark escape routes during power outages and emergencies.

Product applications:

- Emergency exit paths
- Exit door frames
- Fire exits
- Stairways
- Railings
- Fire protection equipment
- Fire alarms
- Door Signs
- Platforms
- Obstruction marking

5 Safety Signage

Effectively communicate important safety messages to employees and visitors.

Product applications:

- Hazard awareness
- Emergency exit points
- Chemical or gas hazards
- Physical hazards
- Safety equipment awareness
- Facility notice signs
- PPE
- Traffic control
- Low light requirements
- Indoor and long term outdoor options available

6 Floor Graphics

Are an excellent medium to communicate safety, warning and general information to people in your facilities.

Product applications:

- Forklift traffic marking
- Fire aisle marking
- Storage area marking
- Fire equipment area marking
- Machine boundaries
- Hazard areas
- Marking locations of first aid and safety equipment
- General workflow

7 Barricade Tape

Used to warn people of an area or situation containing a possible hazard.

Product applications:

- Construction sites
- Hazard control
- Traffic control
- Police or law enforcement
- Fire Departments
- Physical hazards
- Chemical or Biological Hazards

8 DOT/TDG

Dangerous good transportation marks promote public safety when dangerous goods are being handled, offered for transport or transported by road, rail, air, or water.

Product applications:

- Pails and smalls means of containment
- Gaylords and drums
- Tanker trailers
- Shipping boxes
- Transport trailers
- Bottles and bags

What is anti-slip tape?

Provides extra traction to help prevent slip and fall accidents



In the U.S.A., slips, trips and falls make up the majority of general industry accidents. They account for approximately 15% of all accidental deaths, and are the second leading cause behind motor vehicle accidents. Slips, trips and falls are one of most frequently-reported injuries, with approximately 25% of reported accident claims each year.*

Slips and trips can result from some kind of unintended or unexpected change in the contact between the feet and the ground or walking surface. Modifying walking surfaces is a way of preventing slip and trips. Installing pressure-sensitive abrasive strips can further improve safety and reduce risk of slipping and falling by increasing traction on the floor surface.

*Source: based on statistics from United States Department of Labor.

Excellent uses for anti-slip tape

- Stair treads, steps and platforms
- Wet or oily areas
- Transition areas from one floor surface to another
- Floor markings to denote hazards
- Indoor or outdoor slip hazards
- Tow motors, cherry pickers, construction equipment
- Loading docks, Shower areas, Catwalks, Ladders, Scaffolds



HOW TO CHOOSE Anti-Slip Tape



60 Grit Anti-Slip

This is our most commonly used grit level. Offers great indoor and outdoor anti-slip for most general purpose applications.

46 Grit Anti-Slip

Coarser than our 60-grit, this grade offers added traction and is great indoor and outdoor anti-slip for most general purpose applications.

36 Grit Anti-Slip

Offers a deeply textured surface and is recommended for areas with dirt and debris.

24 Grit Anti-Slip

Maximum deep texture and high traction. For areas with large amounts of dirt and debris.

Moppers Friend

36 grit anti-slip with modified surface to allow easy mopping and cleaning without “catching” strings.

Coarse Resilient

Deep embossed textured surface, designed for barefoot applications.

LIGHT MEDIUM HEAVY

60 GRIT → TEXTURE → 24 GRIT

Correct installation procedure



Surface Preparation

It is very important that the surface the tape is being adhered to is free from all contamination such as dirt, dust, grease and oil. A combination of 50/50 alcohol and water solution is usually adequate for removing most contamination. The wiper/cloth should be changed frequently (white cloth recommended). Heavy accumulation may require more aggressive cleaning techniques.



Temperature

Temperature is a critical factor in adhesive bonding and is often over-looked. All our tape products are intended to be applied in temperatures of not less than 50°F (10°C) and not more than listed on their data sheets. In general the closer to room temperature the better the bonding.



Pressure

Tape products should be smoothed down with 15 psi of pressure or more. This will aid in adhesive “wet out” and result in better bonding.



Time

Once the tape has been applied, the adhesive bond will continue to strengthen as it has time to cure. The ambient temperature will affect this bonding time (the colder the slower), but as a general rule good bonding will not be fully achieved for 24-48 hours after the application. Full bond strength will be reached at 72 hours (70°F).



Adhesion Promoters

Some very difficult surfaces may require the use of adhesion promoters to aid in proper bonding. This would be true for low surface energy materials and very porous surfaces. Promoters should be applied per manufacturer’s instructions and must be allowed to fully dry prior to tape application. For porous concrete surfaces you may want to try a Dap® Weldwood® type product for aiding in bonding. Refer to manufacturer’s instructions and SDS sheet for proper handling.



Test

As with most products we highly recommend that you test a small sample of product in its intended use prior to complete installation. Some applications prove to be more difficult and require additional steps to achieve the desired results.



Support

If you would like any assistance or product recommendations, please feel free to contact us at support@incomdirect.com

Premium Grade Anti-Slip Tape

Gator Grip® Traction Tape is our premium brand anti-slip system that helps ensure an OSHA compliant workplace. Constructed from a thick base layer and impregnated with an aggressive 60-grit mineral abrasive compound. The backing has an aggressive acrylic adhesive system for longevity that will form a strong, water-proof bond to most any clean, dry surface while still being temporarily repositionable during the application process.

Gator Grip® is a great choice for both indoor and outdoor environments offering our highest wear resistance and weatherability. Recommended product for long term and OEM applications. Gator Grip® Traction Tape is certified by the National Flooring Safety Institute 101-A "High- Traction", and meets or exceeds OSHA 1910.24, 1910.26 and ANSI B101.1. Gator Grip® offers excellent chemical and oil resistance for a wide variety of applications.



Stock No.	Description	Size
SG3101B	Black Gator Grip® Tape	1" x 60'/roll
SG3102B	Black Gator Grip® Tape	2" x 60'/roll
SG3103B	Black Gator Grip® Tape	3" x 60'/roll
SG3104B	Black Gator Grip® Tape	4" x 60'/roll
SG3106B	Black Gator Grip® Tape	6" x 60'/roll
SG3112B	Black Gator Grip® Tape	12" x 60'/roll
SG3118B	Black Gator Grip® Tape	18" x 60'/roll
SG3124B	Black Gator Grip® Tape	24" x 60'/roll
SG3136B	Black Gator Grip® Tape	36" x 60'/roll
SG3148B	Black Gator Grip® Tape	48" x 60'/roll



Military & Marine Grade Anti-Slip Tape

Our highest performance grit product, Military & Marine Grade anti-slip grit tape offers a large durable abrasive particle providing a slip-resistant surface for improved safety in marine and severe outdoor environments. Product has been tested and used in Military (MIL-PRF-24667C Type XI) & Marine (NAVSEA Approval #05S/2014-162). This aggressive, premium anti-slip grit tape is commonly used in marine, workboat, heavy construction and mining equipment applications.

Follow application instructions to ensure best results. Apply only to a clean, dry, smooth surface above 50°F (10°C).

Custom rolls and sheet sizes available. Call for more details.

Complies with: MIL-PRF-24667C Type XI and NAVSEA Approval #05S/2014-162.

Stock No.	Description	Size
SG3810MIL2	Military/Marine Anti-Slip Tape	2" x 30'/roll
SG3810MIL4	Military/Marine Anti-Slip Tape	4" x 30'/roll
SG3810MIL6	Military/Marine Anti-Slip Tape	6" x 30'/roll



Grit Tape
Applicator Roller

GTR100
Grit Tape Applicator Roller



California Regulatory Warning
WARNING: Cancer and Reproductive Harm -
www.P65Warnings.ca.gov

Premium Grade Colored Anti-Slip Tape

Our line of Gator Grip® Colored anti-slip products are an effective way to offer visual warning of a slip and fall hazard, while offering the same aggressive premium grit features found on our Gator Grip® products.

The surface is an aggressive mineral abrasive compound on a thick liner. Tape will adhere to most any clean, dry surface with an acrylic adhesive system. Tape and adhesive are water, chemical and oil resistant for use in both indoor & outdoor applications.

Try our popular yellow/black hazard striped tape for maximum visual warning and anti-slip protection on stair nosings.



Hazard Stripe

Size	Yellow/Black	Red/White
2" x 60'	SG3902YB	SG3802RW
4" x 60'	SG3904YB	SG3804RW
6" x 60'	SG3906YB	SG3806RW



Solid Color

Size	Green	Yellow	Gray	Red	Clear	Blue	Brown	White
2" x 60'	SG3202G	SG3302Y	SG3402GY	SG3502R	SG3602CL	SG3702BL	SG4302BR	SG4502WH
4" x 60'	SG3204G	SG3304Y	SG3404GY	SG3504R	SG3604CL	SG3704BL	SG4304BR	SG4504WH
6" x 60'	SG3206G	SG3306Y	SG3406GY	SG3506R	SG3606CL	SG3706BL	SG4306BR	SG4506WH

Premium Grade Anti-Slip Cleats

Our Gator Grip® die cut shapes are made from the same material as our Gator Grip® products, but pre-cut to give a finished look on your floor or equipment. All cleats come with rounded corners to reduce tape lifting and flagging. The acrylic adhesive system forms a strong bond to most any clean, dry surface. Gator Grip® cleats work well in both indoor and outdoor applications. Water, chemical and oil resistant for indoor and outdoor usage.

Gator Grip® cleats are NFSI certified as a "High Traction" surface and meet or exceed OSHA 1910.24 and 1910.26. Custom die cut shapes and printing are available to suit your application.

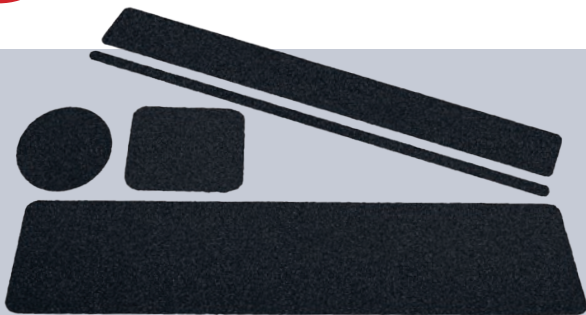

SG3126BHV
6" x 24"/cleat
High Visibility Yellow Stripe

SG3126BGL
6" x 24"/cleat
Glow-in-the-Dark Stripe

SG3126REF
6" x 24"/cleat
Reflective Yellow Stripe

SG3126ATN
6" x 24"/cleat
ATTENTION

SG3126DGR
6" x 24"/cleat
DANGER

SG3126WYS
6" x 24"/cleat
WATCH YOUR STEP

SG3126CAU
6" x 24"/cleat
CAUTION



Note: Specialty cleats are sold 10 pieces per package.

Plain Black Cleats

Stock No.	Description	Size
SG3125BS	Black Gator Grip® Cleats	3/4" x 24"
SG3132BS	Black Gator Grip® Cleats	3" x 24"
SG3126BS	Black Gator Grip® Cleats	6" x 24"
SG3134BS	Black Gator Grip® Cleats	6" x 30"
SG3127BS	Black Gator Grip® Squares	5-1/2" x 5-1/2"
SG3130BS	Black Gator Grip® Circles	5-1/2" dia

Note: Plain black cleats are sold 50 pieces per package.

'CAUTION WATCH YOUR STEP' Anti-Slip Tape

Our worded Gator Grip® tape effectively communicates the hazard and provides a anti-slip surface.



60
GRIT

GATOR GRIP traction tape

Stock No.	Description	Size
SG8903PT	Watch Your Step Anti-Slip Tape	3" x 60'

Stadium Track High Visibility Anti-Slip Tape

Public buildings, stadiums, arenas and parking garages are major areas of concern for slip and fall accidents. Our Stadium Track Tape was developed for these high traffic, high visibility applications. The tape has a muted yellow appearance that adds a visible safety feature, and it maintains its appearance because of the black particles mixed in with the yellow surface. Even after heavy foot traffic the tape will still not look dirty.

The 46-grit anti-slip surface offers a high level of traction and durability. If public safety is part of your program, this is a great product choice. Great for both indoor and outdoor applications and offers excellent water and weather resistance. Meets or exceeds ANSI B101.1.



GATOR GRIP traction tape

46
GRIT

Stock No.	Description	Size
SG6202Y	Stadium Track Anti-Slip Tape	2" x 60'
SG6204Y	Stadium Track Anti-Slip Tape	4" x 60'
SG6206Y	Stadium Track Anti-Slip Tape	6" x 60'

Premium Grade Anti-Slip Footprints

Add a distinctive look to slip and fall prevention program with our die cut footprint traction cleats. Made of the same material as our Gator Grip® tapes and standard cleats, these footprints offer a clear directional pathway indicator for plants, offices or other applications while offering a high degree of anti-slip protection. Try our standard black, safety yellow, or high visibility glow options to fit your particular application.

The surface is an aggressive mineral abrasive compound on a thick base layer. Acrylic adhesive system will adhere to most any clean, dry surface. Cleats are water, chemical and oil resistant for use in both indoor & outdoor applications.



GATOR GRIP traction tape

60
GRIT

Stock No.	Description	Size
SG3110FTP	Black Anti-Slip Footprints	4" x 10"
SG3310FTP	Yellow Anti-Slip Footprints	4" x 10"
SG4210FTP	Glow-in-the-dark Anti-Slip Footprints	4" x 10"

Note: Cleats are sold 24 pieces per package.

Heavy Duty 36-Grit Anti-Slip Tape

Heavy foot traffic and dirty work environments can clog up standard grit products with mud, oil, saw dust, liquids and grease. Our Extra Coarse Gator Grip® offers a very deeply textured (36-grit) surface to continue to offer non-slip protection, even in the dirtiest conditions. Tape can even be spray painted and still maintain a anti-slip surface.

Tape is water-proof for both indoor and outdoor applications, and offers excellent hydrocarbon resistance. This tape has a very aggressive grit surface and is recommended for areas with heavy debris only.

Custom slitting and die cut shapes for OEM applications also available. Great for mud, saw dust, snow and other outdoor applications. Meets or exceeds OSHA 1910.24, 1910.26 and ANSI B101.1.

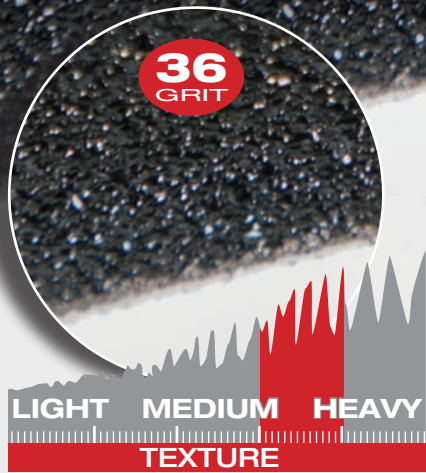

Stock No.	Description	Size
SG6502B	Heavy Duty Anti-Slip Tape	2" x 50'
SG6504B	Heavy Duty Anti-Slip Tape	4" x 50'
SG6506B	Heavy Duty Anti-Slip Tape	6" x 50'
SG6512B	Heavy Duty Anti-Slip Tape	12" x 50'
SG6524B	Heavy Duty Anti-Slip Tape	24" x 50'
SG6536B	Heavy Duty Anti-Slip Tape	36" x 50'
SG6126BS	Heavy Duty Anti-Slip Cleats (50/pkg)	6" x 24"
SG6134BS	Heavy Duty Anti-Slip Cleats (50/pkg)	6" x 30"

Super Coarse XP 24-Grit Anti-Slip Tape

Looking for the ultimate in high traction? Choose our Gator Grip® Super Coarse XP non-skid tape. This product has a large (24-grit) mineral abrasive surface offering our highest level of slip resistance.

Super Coarse XP is a great choice for areas where large amounts of debris are present resulting in reduced surface traction. Tape is suitable for both indoor and outdoor applications and has an aggressive permanent pressure sensitive adhesive system.

Meets or exceeds OSHA 1910.24, 1910.26 and ANSI B101.1.



Stock No.	Description	Size
SG2402B	Super Coarse Anti-SlipTape	2" x 40'
SG2404B	Super Coarse Anti-SlipTape	4" x 40'
SG2406B	Super Coarse Anti-SlipTape	6" x 40'
SG2412B	Super Coarse Anti-SlipTape	12" x 40'

Foil Backed Anti-Slip Tape

Our conformable foil backed anti-slip tape is designed specifically for heavy duty textured surface and stair nosing applications. The foil carrier allows for excellent conformability and will hold its shape to most any embossed or textured surface with its aggressive adhesive.

This product works great on steel tread plate, stair nosing, uneven concrete and most uneven surfaces. Tape has an coarse 46-grit surface.

Great for indoor and outdoor applications with excellent weatherability and water resistance.

Custom slit widths and die cut applications also available. Meets or exceeds OSHA 1910.24, 1910.26 and ANSI B101.1.



Stock No.	Description	Size
SG4102AL	Black Foil Backed Tape	2" x 60'
SG4104AL	Black Foil Backed Tape	4" x 60'
SG4106AL	Black Foil Backed Tape	6" x 60'
SG3902ALS	Yellow/Black Foil Backed Tape	2" x 60'
SG3904ALS	Yellow/Black Foil Backed Tape	4" x 60'
SG3906ALS	Yellow/Black Foil Backed Tape	6" x 60'



Anti-Slip Glow-in-the-dark Tape

Our Photoluminescent Anti-Slip traction tape is perfect for use in emergency exit routing areas such as stairwells, laneways, fire aisle and exits. The high traction surface is combined with a glow in the dark carrier that will aid in finding important emergency routes, equipment and exits during power outage or emergency conditions.

This product has a similar surface and adhesion to our colored and black anti-slip products, but an added safety glow feature. Our tape offers a "GLOW" that is readily visible to the light adjusted eye for up to 6 hours, with the strongest results in the first 60-minutes. Product has an aggressive acrylic adhesive system that will bond to most any clean dry surface.

MEETS OR EXCEEDS STANDARDS:

- DIN 67510
- ASTM E2072-14
- ISO 15370
- EU Marine Equipment Directive
- IMO Resolution A. 752 (18)
- PSPA class B



Stock No.	Description	Size
SG4202PH	Glow-in-the-Dark Anti-Slip Tape	2" x 60'
SG4204PH	Glow-in-the-Dark Anti-Slip Tape	4" x 60'
SG4206PH	Glow-in-the-Dark Anti-Slip Tape	6" x 60'
SG4226PHS50	Glow-in-the-Dark Anti-Slip Cleat (50 per pack)	6" x 24"

Check with local, state/provincial and federal authorities to determine suitability of this photoluminescent product in any egress or emergency exit applications.

'Mop Friendly' Slip-Resistant Tape

Looking to provide an enhanced level of anti-slip protection, but still need to mop the surface for cleaning? Choose our "Mop Friendly" slip-resistant product. We have taken our premium grade anti-slip tape and modified the grit particles to allow a mop to pass over without "catching" strings.

Tape has an aggressive acrylic adhesive system that will bond to most any clean, dry surface and offers a virtually water-proof long term bond.

An excellent product choice for areas where frequent cleaning by mopping is common. Excellent product choice for the marine and boating industries.



Stock No.	Description	Size
SG5102MB	Black Mop Friendly Slip-Resistant Tape	2" x 60'
SG5104MB	Black Mop Friendly Slip-Resistant Tape	4" x 60'
SG5106MB	Black Mop Friendly Slip-Resistant Tape	6" x 60'

Embossed Coarse Resilient Slip-Resistant Tape

Embossed Coarse Resilient Slip-Resistant Tape works great in the office, plant, locker room or areas with bare foot traffic.

This product is not like bath products you would see at the hardware store. This surface has a deep embossed surface that will perform in heavier duty applications, while still being comfortable for bare foot traffic.

We recommend this product in office environments and light plant uses, it can be very easily cleaned and will not trap dirt the way normal grit products can. Surface can also be easily mopped.



Stock No.	Description	Size
PFX2302K	Black Resilient Slip-Resistant Tape	2" x 60'
PFX2304K	Black Resilient Slip-Resistant Tape	4" x 60'
PFX2306K	Black Resilient Slip-Resistant Tape	6" x 60'
PFX2102G	Gray Resilient Slip-Resistant Tape	2" x 60'
PFX2104G	Gray Resilient Slip-Resistant Tape	4" x 60'
PFX2106G	Gray Resilient Slip-Resistant Tape	6" x 60'
PFX2202W	White Resilient Slip-Resistant Tape	2" x 60'
PFX2204W	White Resilient Slip-Resistant Tape	4" x 60'
PFX2206W	White Resilient Slip-Resistant Tape	6" x 60'
PFX2402C	Clear Resilient Slip-Resistant Tape	2" x 60'
PFX2404C	Clear Resilient Slip-Resistant Tape	4" x 60'
PFX2406C	Clear Resilient Slip-Resistant Tape	6" x 60'
PFX2326KBS	Black Resilient Slip-Resistant Cleats (50/pkg)	6" x 24"
PFX2126GBS	Gray Resilient Slip-Resistant Cleats (50/pkg)	6" x 24"
PFX2226WBS	White Resilient Slip-Resistant Cleats (50/pkg)	6" x 24"
PFX2426CBS	Clear Resilient Slip-Resistant Cleats (50/pkg)	6" x 24"

What is floor marking tape?

Improve safety, efficiency and productivity

Floor marking tapes are adhesive tapes used to mark hazards, divide spaces, create aisles, or provide directions. They are commonly used in industrial and manufacturing facilities for floor marking. They are made of multiple different materials, and vary in thickness for a wide range of durability options. Most tapes come in a variety of color options and even hazard stripe warning patterns to meet ANSI requirements and other safety standards.

Tapes are an effective replacement for paints. Tapes are much faster and easier to install and replace. This will dramatically reduce down times when compared to painting aisles and rails. Many floor tapes are scuff and break resistant, unlike paints that will chip and scratch off.

Excellent uses for floor marking tape

- Forklift traffic marking
- Fire aisle marking
- Workflow Marking
- Hazard Marking
- Machine boundaries
- First Aid and Safety Equipment Areas
- Eyewash Stations Areas
- Fire Equipment Areas
- Pipe identification

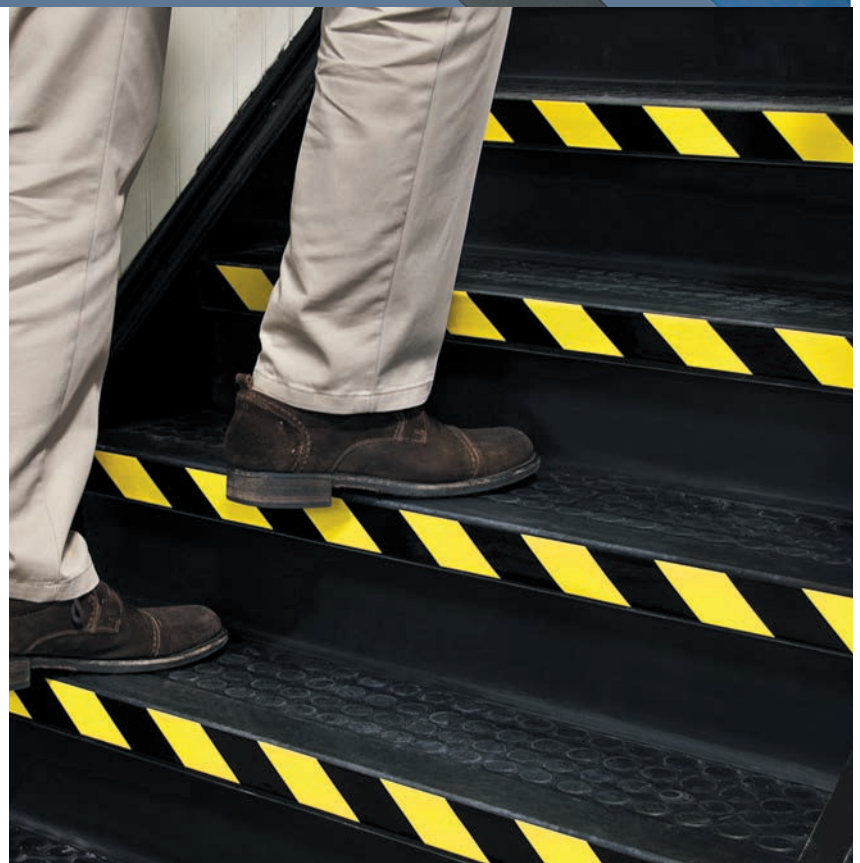

HOW TO CHOOSE Floor Marking Tape



Conformable Tape

General purpose tape with a rubber adhesive system. Available in a large selection of colors and Hazard Stripe patterns.

Laminated Tape

Our conformable tape with an added top film for extra durability. Available in Hazard Stripe patterns.

TuffMark® Tape

Highest durability level in conformable floor marking tapes. Offers great wear, chemical and abrasion resistance along with high tack adhesive strength, while maintaining a low profile design and clean removal.

Armor Stripe

An extremely durable semi rigid marking system. A thick 0.055" poly material is used to provide maximum longevity. Beveled edges reduce wheel impact on forklifts and make cleaning easier.

Worded Floor Tape

Offers addition safety and informational messages to your facility while maintaining anti-slip compliance.

Correct installation procedure



Surface Preparation

It is very important that the surface the tape is being adhered to is free from all contamination such as dirt, dust, grease and oil. A combination of 50/50 alcohol and water solution is usually adequate for removing most contamination. The wiper/cloth should be changed frequently (white cloth recommended). Heavy accumulation may require more aggressive cleaning techniques.



Temperature

Temperature is a critical factor in adhesive bonding and is often over-looked. All our tape products are intended to be applied in temperatures of not less than 50°F (10°C) and not more than listed on their data sheets. In general the closer to room temperature the better the bonding.



Pressure

Tape products should be smoothed down with 15 psi of pressure or more. This will aid in adhesive "wet out" and result in better bonding.



Time

Once the tape has been applied, the adhesive bond will continue to strengthen as it has time to cure. The ambient temperature will affect this bonding time (the colder the slower), but as a general rule good bonding will not be fully achieved for 24-48 hours after the application. Full bond strength will be reached at 72 hours (70°F).



Adhesion Promoters

Some very difficult surfaces may require the use of adhesion promoters to aid in proper bonding. This would be true for low surface energy materials and very porous surfaces. Promoters should be applied per manufacturer's instructions and must be allowed to fully dry prior to tape application. For porous concrete surfaces you may want to try a Dap® Weldwood® type product for aiding in bonding. Refer to manufacturer's instructions and SDS sheet for proper handling.



Test

As with most products we highly recommend that you test a small sample of product in its intended use prior to complete installation. Some applications prove to be more difficult and require additional steps to achieve the desired results.



Support

If you would like any assistance or product recommendations, please feel free to contact us at support@incomdirect.com

Aisle Marking Conformable Tape

We offer a wide selection of quality aisle marking and pipe banding tapes. Our aisle marking tapes are made from a durable film with a rubber adhesive system that will adhere to most any clean, dry surface.

This matte smooth conformable tape that is great for marking hazards on floors, walls and equipment. Commonly used in aisle demarcation, color coding and pipe banding applications.

All tapes are made in a wide array of OSHA colors that meet ANSI Z535.1 and offer excellent durability and chemical resistance.



Safety Red

Fire protection equipment and apparatus, danger signs, containers of flammable liquids, lights at barricades, stop buttons/switches.

Safety Orange

Signs and equipment designating dangerous or energized machines/equipment.

Safety Yellow

Specific physical hazards including falling, tripping and striking and designating caution.

Safety Green

Safety information and first aid equipment.

Safety Blue

Information not immediately safety related (i.e. property policies).

Purple, Gray, Black and White

The significance of these colors may be defined by the end user.

Size	Safety Yellow	Safety Green	Emerald Green	Safety Red	Safety White	Safety Black	Safety Gray	Safety Brown	Safety Orange	Safety Purple	Safety Blue	Light Blue
1" x 108'	PST110	PST111	PST123	PST112	PST113	PST115	PST116	PST117	PST118	PST122	PST121	PST124
2" x 108'	PST210	PST211	PST223	PST212	PST213	PST215	PST216	PST217	PST218	PST222	PST221	PST224
3" x 108'	PST310	PST311	PST323	PST312	PST313	PST315	PST316	PST317	PST318	PST322	PST321	PST324
4" x 108'	PST410	PST411	PST423	PST412	PST413	PST415	PST416	PST417	PST418	PST422	PST421	PST424
6" x 108'	PST610	PST611	PST623	PST612	PST613	PST615	PST616	PST617	PST618	PST622	PST621	PST624
1" x 180'	PST110XL	PST111XL	PST123XL	PST112XL	PST113XL	PST115XL	PST116XL	PST117XL	PST118XL	PST122XL	PST121XL	PST124XL
2" x 180'	PST210XL	PST211XL	PST223XL	PST212XL	PST213XL	PST215XL	PST216XL	PST217XL	PST218XL	PST222XL	PST221XL	PST224XL
3" x 180'	PST310XL	PST311XL	PST323XL	PST312XL	PST313XL	PST315XL	PST316XL	PST317XL	PST318XL	PST322XL	PST321XL	PST324XL
4" x 180'	PST410XL	PST411XL	PST423XL	PST412XL	PST413XL	PST415XL	PST416XL	PST417XL	PST418XL	PST422XL	PST421XL	PST424XL
6" x 180'	PST610XL	PST611XL	PST623XL	PST612XL	PST613XL	PST615XL	PST616XL	PST617XL	PST618XL	PST622XL	PST621XL	PST624XL

California Regulatory Warning
 **WARNING: Cancer and Reproductive Harm -**
www.P65Warnings.ca.gov

Hazard Warning

Conformable Tape

Our most popular conformable Hazard Warning Tape. These tapes will quickly bring attention to any workplace hazard. Tape has a smooth, semi-matte surface. Great product for use on floors, walls, pipes and equipment.

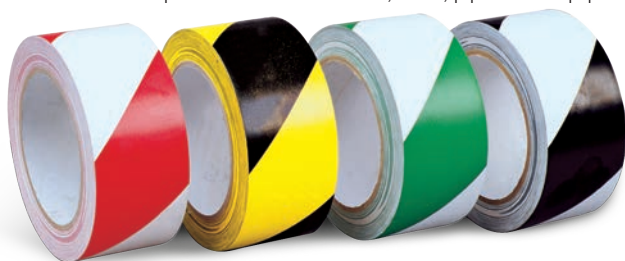

CONFORMABLE

Color	2" x 54'	3" x 54'	4" x 54'	2" x 108'	3" x 108'	4" x 108'
Yellow/Black	VHT210	VHT310	VHT410	WT2110	WT2130	WT2140
Red/White	VHT211	VHT311	VHT411	WT2200	WT2210	WT2220
Black/White	VHT212	VHT312	VHT412	WT2300	WT2310	WT2320
Green/White	VHT213	VHT313	VHT413	WT2400	WT2410	WT2420

Hazard Warning

Laminated Tape

We take our Hazard Marking Tape and apply a durable, clear laminating film on top. The smooth gloss finish will resist wear and is easily cleaned.



LAMINATED

Color	2" x 54'	3" x 54'	4" x 54'	2" x 108'	3" x 108'	4" x 108'
Yellow/Black	LWT210	LWT310	LWT410	LWT220	LWT320	LWT420
Red/White	LWT211	LWT311	LWT411	LWT221	LWT321	LWT421
Black/White	LWT212	LWT312	LWT412	LWT222	LWT322	LWT422
Green/White	LWT213	LWT313	LWT413	LWT223	LWT323	LWT423

Red/White Hazard Areas to be kept clear for safety reasons.

Yellow/Black Hazard Areas which present physical or health risks to employees.

Green/White Hazard Areas that are related to first aid or may be defined by the end user.

White/Black Hazard Areas to be kept clear for operational purposes.

California Regulatory Warning

WARNING: Cancer and Reproductive Harm - www.P65Warnings.ca.gov

Checkerboard

Laminated Tape

A unique way to draw attention to your workplace hazards. Our Checkerboard Tape has 1" square pattern and is protected with a clear lamination that looks great and resists wear. All Checkerboard Tapes have an aggressive adhesive system that will adhere to most any clean, dry surface.

Color	2" x 54'	3" x 54'	4" x 54'	2" x 108'	3" x 108'	4" x 108'
Yellow/Black	LCB210	LCB310	LCB410	LCB220	LCB320	LCB420
Red/White	LCB211	LCB311	LCB411	LCB221	LCB321	LCB421
Black/White	LCB212	LCB312	LCB412	LCB222	LCB322	LCB422
Green/White	LCB213	LCB313	LCB413	LCB223	LCB323	LCB423



Self Lamination

Clear Rolls

Our Floor Tape Lamination will extend the life of your floor markings, while enhancing slip resistance.

FTL300 - 3" x 54'
FTL400 - 4" x 54'
FTL500 - 5" x 54'



Aisle Marking

Tape Dispenser

Use our aisle tape dispenser to quickly install large aisle marking projects. Maximum 4" wide rolls.

WTD200

California Regulatory Warning

WARNING: Cancer and Reproductive Harm - www.P65Warnings.ca.gov

TuffMark®

Ultra Durable Floor Marking Tape

TuffMark® provides a long lasting solution for marking floors, aisles, walkways and work flow in your facilities. This extra-tough, low profile, easy to apply Floor Marking product is made with heavy duty materials making this tape highly durable, as well as abrasion and chemical resistant.

The rigid construction makes this tape easy to install as well as easy to clean and maintain. The aggressive adhesive will bond to most floors making this tape resistant to tearing, wrinkling or lifting even under heavy forklift traffic. Once applied, the low profile design makes this tape a great choice for use in areas with forklift, hand truck or pedestrian traffic. Removes from most floor surfaces cleanly without chipping, tearing or leaving unsightly adhesive residue.

TuffMark® is available in a wide selection of sizes and can be customized with a printed message or specific color.

TuffMark® Standards:

- ANSI Standard Z535.1 for color
- Average dry BPN: 125 (Dynamic slip resistance using ASTM E303-93 (2013) pendulum test method)
- Average dry dynamic coefficient of friction: Overall average: Dry 0.60 (ANSI A137.1 flooring slip resistance test - dry)



Size	Safety Yellow	Safety Green	Safety Red	Safety White	Safety Black	Safety Orange	Safety Blue	Red/White	Yellow/Black	White/Black
2" x 100'	TM1102Y	TM1102G	TM1102R	TM1102W	TM1102K	TM1102N	TM1102B	TM1202RW	TM1202YB	TM1202BW
3" x 100'	TM1103Y	TM1103G	TM1103R	TM1103W	TM1103K	TM1103N	TM1103B	TM1203RW	TM1203YB	TM1203BW
4" x 100'	TM1104Y	TM1104G	TM1104R	TM1104W	TM1104K	TM1104N	TM1104B	TM1204RW	TM1204YB	TM1204BW

Armadillo Tape

Ultra Durable Floor Tape

In response to customer demand for a longer wearing floor tape product we have developed our line of ultra durable Armadillo tapes. These tapes offer our best level of durability for indoor and outdoor applications.

The tape is constructed on a thick reinforced carrier with an aggressive weather-proof adhesive system. The surface is a mild abrasive surface that is durable, slip-resistant and also has low level reflective properties. Tape will adhere to a wide variety of industrial surfaces including smooth concrete, asphalt, wood and steel.

Low profile design will ensure that the tape does not present a hazard to fork truck traffic or pedestrians. Tape can be easily cleaned with standard industrial cleaning machines and procedures.



Size	Yellow	Green	Red	White	Blue
3" x 108'	ARM310	ARM311	ARM312	ARM313	ARM321

California Regulatory Warning
WARNING: Cancer and Reproductive Harm -
www.P65Warnings.ca.gov

Floor Arrows & Dots

Our colored arrows and dots make a great choice for marking direction of travel or demarcation of hazards. Commonly used for production work flow, inventory management and pedestrian directional aids.

Arrows and dots are all made from a durable solid color material so there is no print to wear off. Made with a permanent adhesive backing. Choose from a wide selection of stock colors.

We also offer custom sizes and colors as special request.



Size	White	Black	Green	Red	Blue	Yellow	Qty/Roll
4" Arrow	VA400W	VA400K	VA400G	VA400R	VA400B	VA400Y	100
3" Dots	VC300W	VC300K	VC300G	VC300R	VC300B	VC300Y	500

California Regulatory Warning
 **WARNING: Cancer and Reproductive Harm -**
www.P65Warnings.ca.gov

Safety Message

Floor Tape

Worded floor tapes are a great way to effectively and permanently communicate safety messages and hazards to your employees and visitors.

These tapes are constructed for long term durability. All tapes have a slip resistant clear over-lamination to offer long-term protection to the printed messages. All tapes provide a slip resistant surface in compliance with UL 410-COF for floor graphics.

Custom text and graphics also available. Contact customer service for more details.



CAUTION

WTP112 (3" x 54'/roll)

DANGER

WTP113 (3" x 54'/roll)

DANGER

WTP114 (3" x 54'/roll)



SLIPPERY WHEN WET

WTP100 (3" x 54'/roll)



SAFETY GLASSES

WTP101 (3" x 54'/roll)



SAFETY FOOTWEAR

WTP102 (3" x 54'/roll)



FORK LIFT TRAFFIC

WTP103 (3" x 54'/roll)



HEARING PROTECTION

WTP104 (3" x 54'/roll)



HARD HAT AREA

WTP108 (3" x 54'/roll)



FIRE AISLE - KEEP CLEAR

WTP105 (3" x 54'/roll)



EMERGENCY EXIT

WTP106 (3" x 54'/roll)



ARC FLASH BOUNDARY

WTP107 (3" x 54'/roll)



AUTHORIZED PERSONNEL ONLY

WTP109 (3" x 54'/roll)



FIRE EQUIPMENT

WTP110 (3" x 54'/roll)



WTP111 (3" x 54'/roll)

What are 5S Lean Workplace Markings?

Improve safety, efficiency
and productivity

5S is a workplace organization method used in industrial manufacturing around the world. These markers aid in organizing a work space for efficiency, effectiveness, and safety by identifying and storing the items used, maintaining the area and items, and sustaining the new order.



Excellent Uses for 5S Lean Markers

- Assisting in 5S compliance
- Directing work flow
- Sorting and organizing
- Warehousing
- Marking product locations

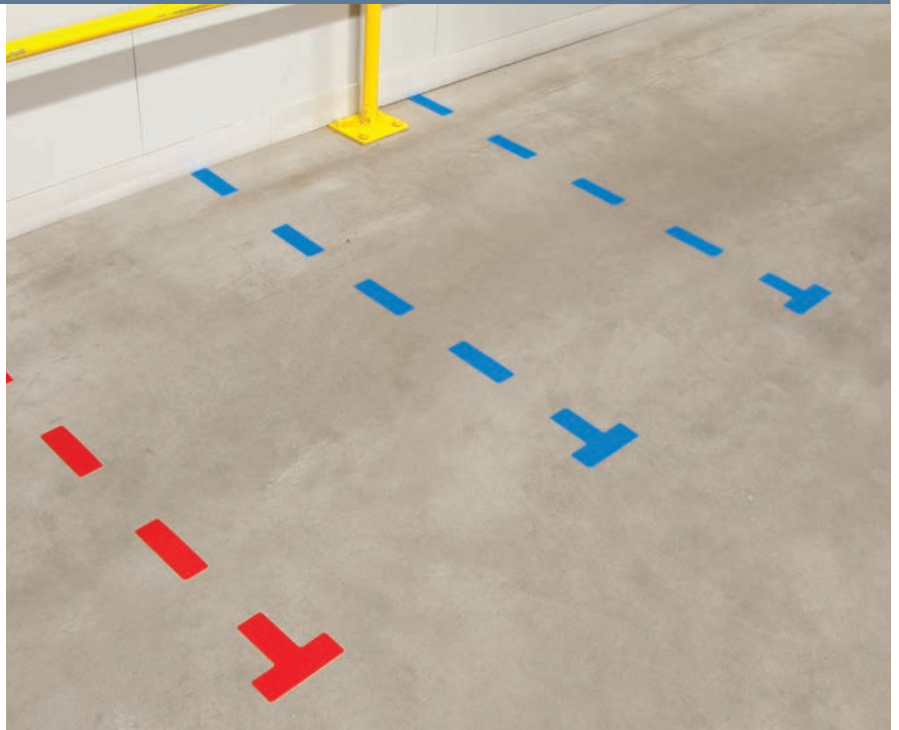

HOW TO CHOOSE 5S Lean Markers



Textured Markers

These markers are made with a thick textured anti-slip lamination. This provides extended durability and will stand up to heavy pedestrian traffic.

TuffMark Markers

Tuff Mark® provides a long lasting solution for 5S Lean Marking. This extra tough, low profile, easy to apply Floor Marking product is made with heavy duty materials making these markers highly durable, as well as abrasion and chemical resistant. Designed for use in areas with forklift, hand truck, or pedestrian traffic.

Armor Stripe Markers

An extremely durable semi rigid marking system. A thick 0.055" poly material is used to provide maximum longevity. Beveled edges reduce wheel impact on forklifts and make cleaning easier. Our highest durability level for 5S Markers.

Correct installation procedure



Surface Preparation

It is very important that the surface the tape is being adhered to is free from all contamination such as dirt, dust, grease and oil. A combination of 50/50 alcohol and water solution is usually adequate for removing most contamination. The wiper/cloth should be changed frequently (white cloth recommended). Heavy accumulation may require more aggressive cleaning techniques.



Temperature

Temperature is a critical factor in adhesive bonding and is often over-looked. All our tape products are intended to be applied in temperatures of not less than 50°F (10°C) and not more than listed on their data sheets. In general the closer to room temperature the better the bonding.



Pressure

Tape products should be smoothed down with 15 psi of pressure or more. This will aid in adhesive "wet out" and result in better bonding.



Time

Once the tape has been applied, the adhesive bond will continue to strengthen as it has time to cure. The ambient temperature will affect this bonding time (the colder the slower), but as a general rule good bonding will not be fully achieved for 24-48 hours after the application. Full bond strength will be reached at 72 hours (70°F).



Adhesion Promoters

Some very difficult surfaces may require the use of adhesion promoters to aid in proper bonding. This would be true for low surface energy materials and very porous surfaces. Promoters should be applied per manufacturer's instructions and must be allowed to fully dry prior to tape application. For porous concrete surfaces you may want to try a Dap® Weldwood® type product for aiding in bonding. Refer to manufacturer's instructions and SDS sheet for proper handling.



Test

As with most products we highly recommend that you test a small sample of product in its intended use prior to complete installation. Some applications prove to be more difficult and require additional steps to achieve the desired results.



Support

If you would like any assistance or product recommendations, please feel free to contact us at support@incomdirect.com

Textured Anti-Slip

5S Lean Markers

These markers are specifically designed for use in "Lean Manufacturing" 5S applications for aiding in floor layout, sorting and workflow.

These markers are made with a thick textured anti-slip lamination. This provides extended durability and will stand up to heavy pedestrian traffic. The aggressive adhesive backing will work on most clean, dry and smooth floors.

Textured anti-slip surface provides extended durability.

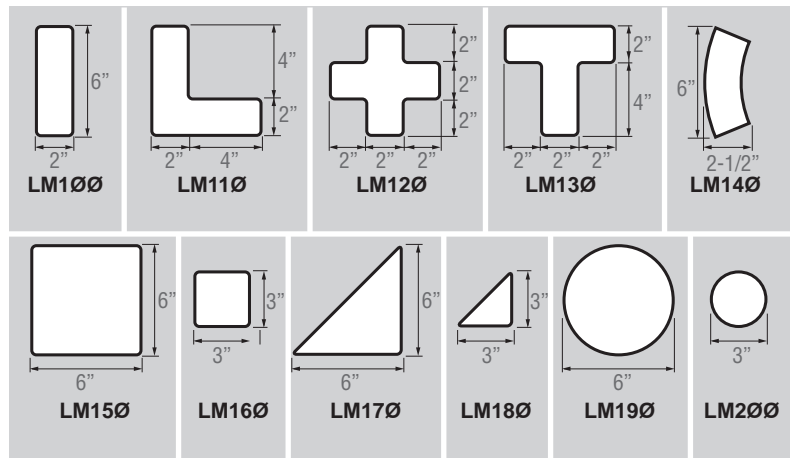

HOW TO ORDER:

SELECT SIGN - LM100		SELECT COLOR CODE - W				ADD TOGETHER - LM100W	
Color	White	Black	Yellow	Red	Blue	Green	Orange
Code	W	K	Y	R	B	G	N

Note: Markers are sold 25 pieces per package.

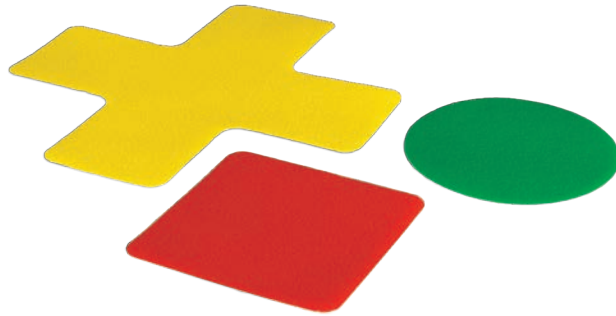

TuffMark®

Laminated 5S Lean Markers

TuffMark® provides a long lasting solution to aid in floor layout, sorting and workflow to help comply with 5S Lean manufacturing standards. This extra-tough, low profile, easy to apply Floor Marking product is made with heavy duty materials making these markers highly durable, as well as abrasion and chemical resistant.

These markers are made with the same material as our TuffMark® tapes and will match both construction and color when used together.

Extra-tough, low profile heavy duty abrasion and chemical resistant material.

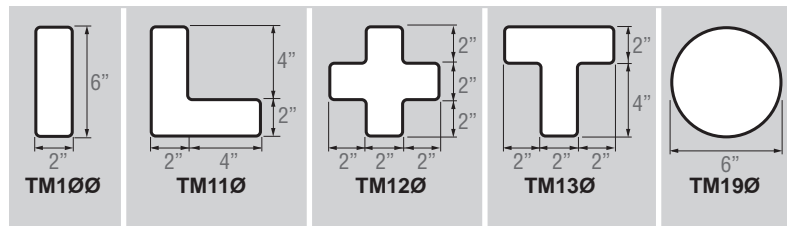

HOW TO ORDER:

SELECT SIGN - TM100		SELECT COLOR CODE - W				ADD TOGETHER - TM100W	
Color	White	Black	Yellow	Red	Blue	Green	Orange
Code	W	K	Y	R	B	G	N

Note: Markers are sold 20 pieces per package.



TUFFMARK®

ArmorStripe

Ultra Durable Tapered Edge 5S Lean Markers

ArmorStripe offers an extremely durable system to aid in floor layout, sorting and workflow for 5S Lean manufacturing standards.

These markers are made from a through-color solid 0.055" thick rigid polyethylene surface with an ultra tacky heavy coat weight adhesive backing. They will adhere to most any clean smooth surface with a very high tack bond while offering a low residue removal from most applications.

Edges of all shapes have been tapered to reduce wheel impact. Solid through-color plastic offers extended durability.

Edges of all shapes have been tapered to reduce wheel impact. Solid through-color plastic offers extended durability.

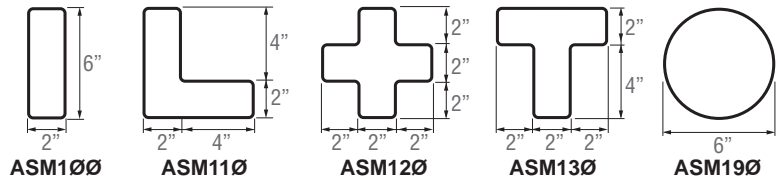

HOW TO ORDER:

SELECT SIGN - ASM100	SELECT COLOR CODE - W				ADD TOGETHER - ASM100W		
Color	White	Black	Yellow	Red	Blue	Green	Orange
Code	W	K	Y	R	B	G	N

Note: Markers are sold 10 pieces per package.



**ARMOR
STRIPES**

ArmorStripe "Lock-It"

Ultra Durable 5S Lean Markers

ArmorStripe Lock-It offers an extremely durable system to aid in floor layout, sorting and workflow for 5S Lean manufacturing standards. These pieces will lock together in a jigsaw puzzle format to allow for continuous runs of this highly durable floor marking solution.

These markers are made from a through-color solid 0.055" thick rigid polyethylene surface with an ultra tacky heavy coat weight adhesive backing with a locking end section. They will adhere to most any clean smooth surface with a very high tack bond while offering a low residue removal from most applications.

Edges of all shapes have been tapered to reduce wheel impact. Solid through-color plastic offers extended durability.

Edges of all shapes have been tapered to reduce wheel impact. Solid through-color plastic offers extended durability.

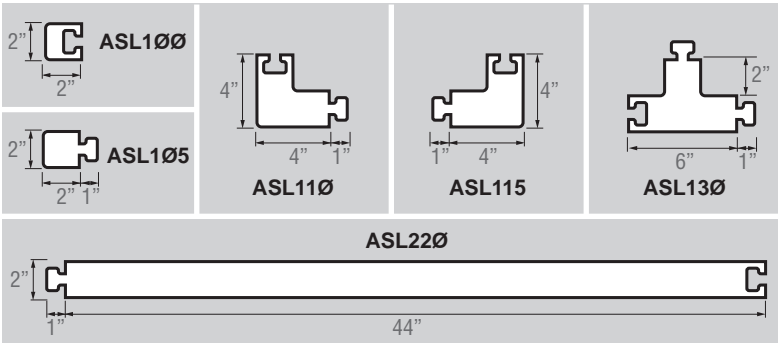

HOW TO ORDER:

SELECT SIGN - ASL100	SELECT COLOR CODE - W				ADD TOGETHER - ASL100W		
Color	White	Black	Yellow	Red	Blue	Green	Orange
Code	W	K	Y	R	B	G	N

Note: Markers are sold 10 pieces per package.



**ARMOR
STRIPES**

5S Shadow Board Storage Organizers

Organize your workspace by clearly marking where equipment should be stored and easily notice when something is missing. These shadow boards adopt the 5S method of organization by creating a designated space for equipment and tools. Employees can be sure they are following the correct organizational procedure when carrying out housekeeping tasks.

The 5S shadow board is made from 5mm thick Aluminum Composite Material (ACM) with a durable print finish. All hanger hardware for the equipment are included and come with assembly instructions.

Shadow boards are shipped with equipment hanging hardware included, that is easily installed by the user.



Looking for custom options?

If you need a custom option, we can work directly with you to create a shadow board for your tools or specialized equipment. They can be designed to any size, shape or color to suit your workplace needs.

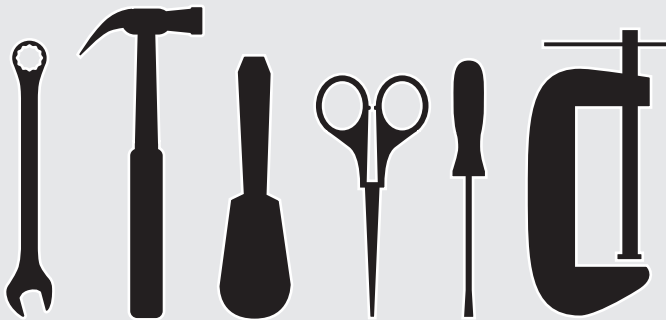

DRY ZONE

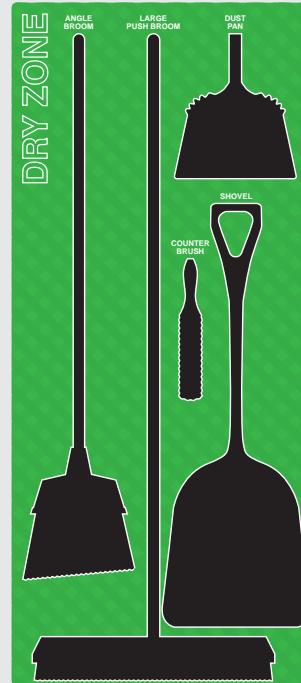

Shadow Board: 30" x 68"

- SB1001** Includes:
- Shadow Board
 - Hanger Hardware

- SB1001KIT** Includes:
- Shadow Board
 - Hanger Hardware
 - Angle Broom
 - Large Push Broom
 - Dust Pan
 - Counter Brush
 - Shovel

DRY ZONE FLOOR

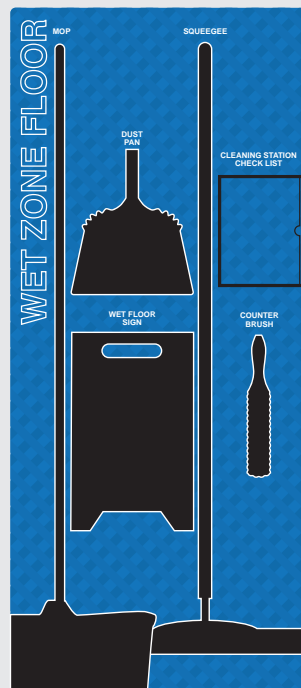

Shadow Board: 30" x 68"
Bucket Floor Sign: 17" Dia

- SB1004** Includes:
- Shadow Board
 - Check List Holder
 - Hanger Hardware
 - Mop Bucket Floor Sign

- SB1004KIT** Includes:
- Shadow Board
 - Check List Holder
 - Mop Bucket Floor Sign
 - Hanger Hardware
 - Mop
 - Mop Bucket
 - Dust Pan
 - Wet Floor Sign
 - Squeegee
 - Counter Brush



California Regulatory Warning
 **WARNING:** Cancer and Reproductive Harm - www.P65Warnings.ca.gov

WET ZONE TANK

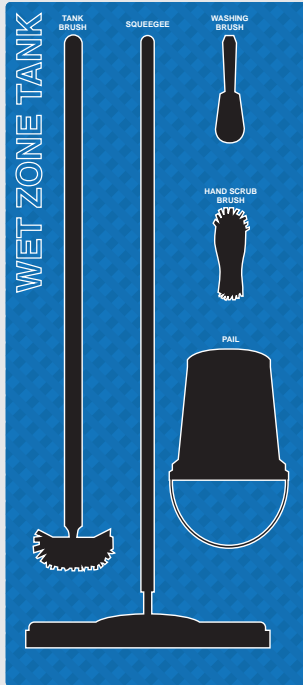

- SB1002** Includes:
- Shadow Board
 - Hanger Hardware

Shadow Board: 30" x 68"

WET & DRY ZONE

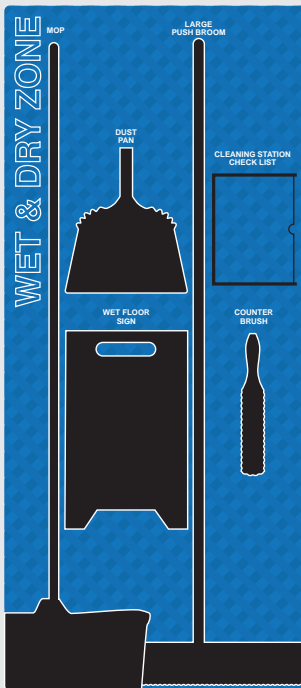

- SB1003** Includes:
- Shadow Board
 - Check List Holder
 - Hanger Hardware
 - Mop Bucket Floor Sign

- SB1003KIT** Includes:
- Shadow Board
 - Check List Holder
 - Mop Bucket Floor Sign
 - Hanger Hardware
 - Mop
 - Mop Bucket
 - Dust Pan
 - Wet Floor Sign
 - Large Push Broom
 - Counter Brush



Shadow Board: 30" x 68"
Bucket Floor Sign: 17" Dia

HOUSEKEEPING



- SB1000** Includes:
- Shadow Board
 - Hanger Hardware

- SB1000KIT** Includes:
- Shadow Board
 - Hanger Hardware
 - Dust Pan
 - Standing Dust Pan
 - Large Push Broom
 - Counter Brush
 - Angle Broom

Shadow Board: 30" x 68"

WRENCH SET

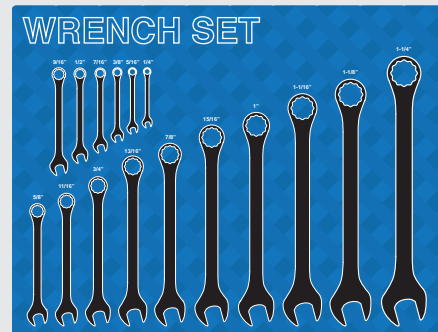

- SB1005** Includes:
- Shadow Board
 - Hanger Hardware

Shadow Board: 26" x 20"

California Regulatory Warning
 **WARNING:** Cancer and Reproductive Harm - www.P65Warnings.ca.gov.

What is Glow-in-the-dark Tape?

Designed for added safety during blackout emergencies

Photoluminescent tape is designed for added safety during blackouts, evacuations and other emergencies. This glow-in-the-dark tape is commonly used to help improve the safety in warehouses, manufacturing facilities, and even on emergency equipment.



Excellent uses for Glow-in-the-dark tape

- Emergency exit paths
- Exit door frames
- Stairways
- Railings
- Fire protection equipment
- Fire alarms
- Platforms
- Obstructions

Check with local, state/provincial and federal authorities to determine suitability of this photoluminescent product in any egress or emergency exit applications.

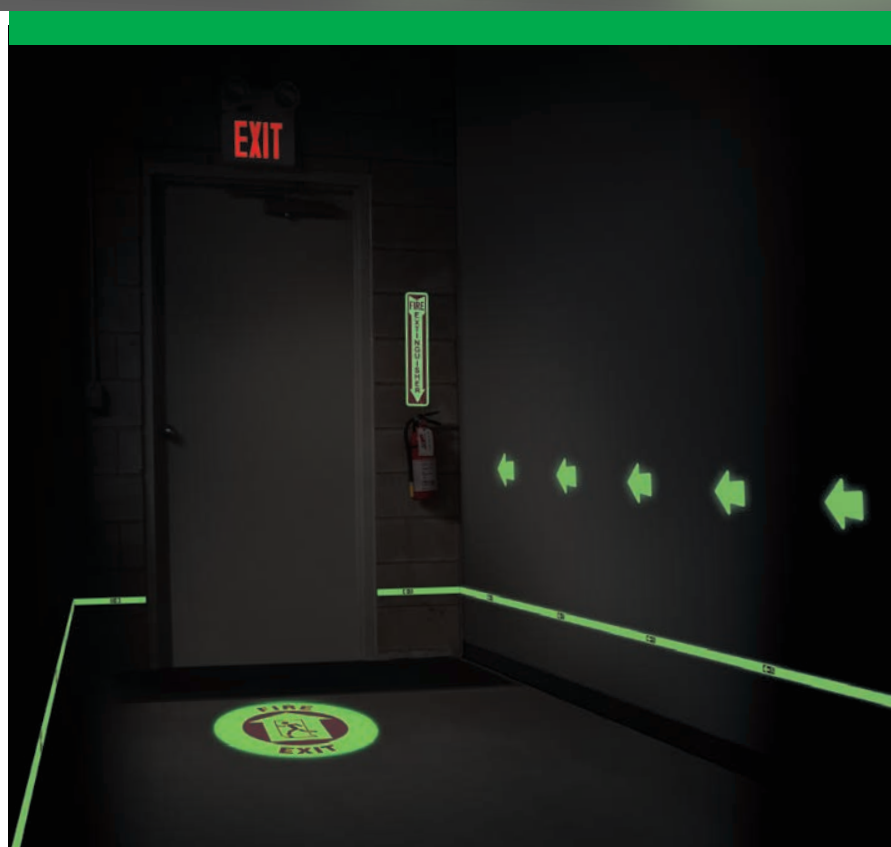

EXIT

HOW TO CHOOSE Glow Tape



Plain Glow-in-the-dark

Industrial safety grade available in assorted widths.

Hazard Glow-in-the-dark

Our industrial grade photoluminescent tape with added hazard stripes. Enhances visual awareness during both standard lighting conditions as well as black out and emergency situations.

Anti-Slip Glow-in-the-dark

Our industrial grade photoluminescent tape with a top coat of our clear Gator Grip® anti-slip tape. Designed for platforms, floors, stairwells and other emergency exit route floors where added slip resistance is needed.

Check with local, state/provincial and federal authorities to determine suitability of this photoluminescent product in any egress or emergency exit applications.

Correct installation procedure



Surface Preparation

It is very important that the surface the tape is being adhered to is free from all contamination such as dirt, dust, grease and oil. A combination of 50/50 alcohol and water solution is usually adequate for removing most contamination. The wiper/cloth should be changed frequently (white cloth recommended). Heavy accumulation may require more aggressive cleaning techniques.



Temperature

Temperature is a critical factor in adhesive bonding and is often over-looked. All our tape products are intended to be applied in temperatures of not less than 50°F (10°C) and not more than listed on their data sheets. In general the closer to room temperature the better the bonding.



Pressure

Tape products should be smoothed down with 15 psi of pressure or more. This will aid in adhesive "wet out" and result in better bonding.



Time

Once the tape has been applied, the adhesive bond will continue to strengthen as it has time to cure. The ambient temperature will affect this bonding time (the colder the slower), but as a general rule good bonding will not be fully achieved for 24-48 hours after the application. Full bond strength will be reached at 72 hours (70°F).



Adhesion Promoters

Some very difficult surfaces may require the use of adhesion promoters to aid in proper bonding. This would be true for low surface energy materials and very porous surfaces. Promoters should be applied per manufacturer's instructions and must be allowed to fully dry prior to tape application. For porous concrete surfaces you may want to try a Dap® Weldwood® type product for aiding in bonding. Refer to manufacturer's instructions and SDS sheet for proper handling.



Test

As with most products we highly recommend that you test a small sample of product in its intended use prior to complete installation. Some applications prove to be more difficult and require additional steps to achieve the desired results.



Support

If you would like any assistance or product recommendations, please feel free to contact us at support@incomdirect.com

Anti-Slip Glow-in-the-dark Tape

Our photoluminescent anti-slip traction tape is perfect for use in emergency exit routing areas such as stairwells, laneways, fire aisle and exits. The high traction surface is combined with a glow in the dark carrier that will aid in finding important emergency routes, equipment and exits during power outage or emergency conditions.

This product has a similar surface and adhesion to our colored and black anti-slip products, but an added safety glow feature. Our tape offers a "GLOW" that is readily visible to the light adjusted eye for up to 6 hours, with the strongest results in the first 60-minutes. Product has an aggressive acrylic adhesive system that will bond to most any clean dry surface.

MEETS OR EXCEEDS STANDARDS:

- DIN 67510
- ASTM E2072-14
- ISO 15370
- EU Marine Equipment Directive
- IMO Resolution A. 752 (18)
- PSPA class B



Stock No.	Description	Size
SG4202PH	Glow-in-the-Dark Anti-Slip Tape	2" x 60'
SG4204PH	Glow-in-the-Dark Anti-Slip Tape	4" x 60'
SG4206PH	Glow-in-the-Dark Anti-Slip Tape	6" x 60'
SG4226PHS50	Glow-in-the-Dark Anti-Slip Cleat (50 per pack)	6" x 24"

Check with local, state/provincial and federal authorities to determine suitability of this photoluminescent product in any egress or emergency exit applications.

Arrows & Dots Glow-in-the-dark Marking

Our die cut arrows and dots can be used to further augment your escape routing program. All products are made from a premium safety grade photoluminescent material and will "GLOW" 6+ hours.

MEETS OR EXCEEDS STANDARDS:

- DIN 67510
- ASTM E2072-14
- ISO 15370
- EU Marine Equipment Directive
- IMO Resolution A. 752 (18)
- PSPA class B



Stock No.	Description	Size	Qty/Roll
GTAR40	Arrows	4"	100
GTCL30	Circle	3"	100

Check with local, state/provincial and federal authorities to determine suitability of this photoluminescent product in any egress or emergency exit applications.

Directional Fire Exit Glow-in-the-dark Tape

Our photoluminescent directional emergency exit tape is intended to be installed close to ground level, to be visible where a person would be crawling under smoke. Tapes will "GLOW" 6+ hours..

MEETS OR EXCEEDS STANDARDS:

- DIN 67510
- ASTM E2072-14
- ISO 15370
- EU Marine Equipment Directive
- IMO Resolution A. 752 (18)
- PSPA class B



Stock No.	Description	Size
GT130EXL	Exit Left	1" x 30'
GT130EXR	Exit Right	1" x 30'

Check with local, state/provincial and federal authorities to determine suitability of this photoluminescent product in any egress or emergency exit applications.

Hazard & Plain Glow-in-the-dark Tape

Our photoluminescent tapes will "GLOW" 6+ hours. This product comes with an aggressive permanent pressure sensitive adhesive that will adhere to most any clean, dry surface.

MEETS OR EXCEEDS STANDARDS:

- DIN 67510
- ASTM E2072-14
- ISO 15370
- EU Marine Equipment Directive
- IMO Resolution A. 752 (18)
- PSPA class B

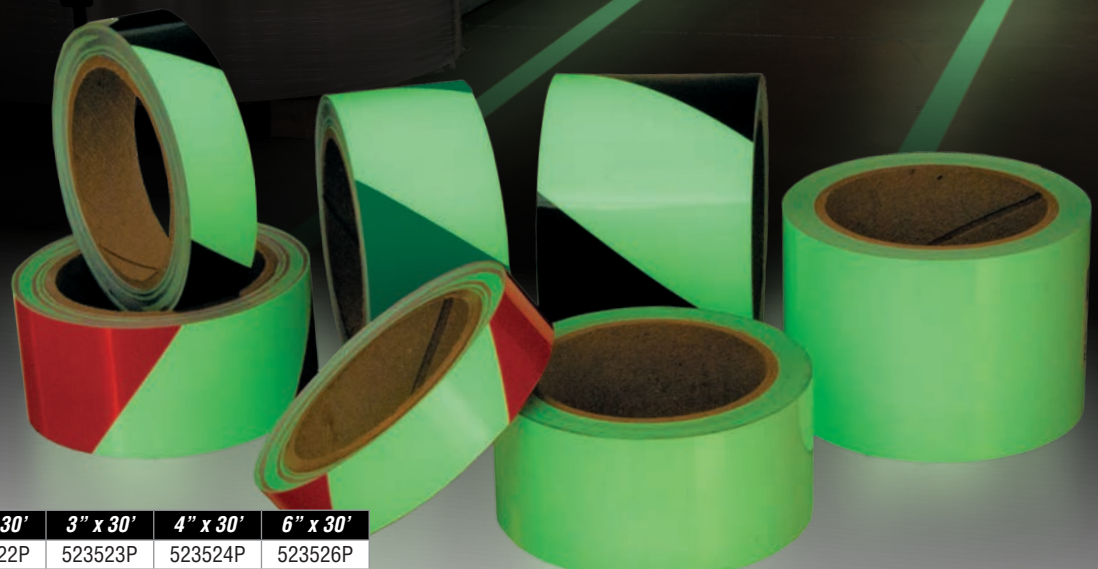

Size	1" x 30'	2" x 30'	3" x 30'	4" x 30'	6" x 30'
Plain	523521P	523522P	523523P	523524P	523526P
Black Hazard	GT130BKB	GT230BKB	GT330BKB	GT430BKB	GT630BKB
Red Hazard	GT130RDB	GT230RDB	GT330RDB	GT430RDB	GT630RDB
Green Hazard	GT130GNB	GT230GNB	GT330GNB	GT430GNB	GT630GNB

Check with local, state/provincial and federal authorities to determine suitability of this photoluminescent product in any egress or emergency exit applications.

What is barricade tape?

Used to warn people of an area or situation containing a possible hazard

Barricade tape acts as a minor impediment to prevent accidental entrance to that area or situation that could result in harm or liability. The tape is often wrapped and affixed as a visual warning sign and demarcation, for instance against entering a dangerous area, such as an industrial or commercial building site, or a roadworks construction site. Barricade tape is also known as construction tape, barrier tape, or caution tape.



Common uses for barricade tape

- Construction sites
- Hazard Control
- Traffic control
- Police or Law enforcement
- Fire Departments
- Physical hazards
- Chemical or Biological Hazards



HOW TO CHOOSE Barricade Tape



Value Grade

Our best value thinner gauge film for general light duty usage.

Contractor Grade

A great blend of performance and value for the contractor markets.

Plus Grade

A medium thickness film built for extended stability in windy conditions.

Heavy Duty Grade

Our thickest grade poly film for the best durability in a wide range of applications.

Reinforced Grade

Our reinforced product offers the ultimate in durability under the toughest conditions.



Custom Printed

Add a distinctive touch to your job site while promoting your company at the same time. We offer a complete customization program. Add your company's name and logo to your barricade tape with your choice of message.

Please contact your customer service representative to start your custom barricade tape project today.

Choose your color

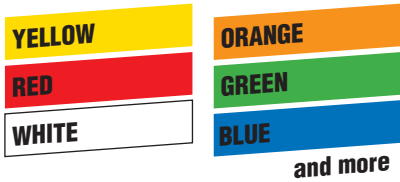

Choose your message



Add your logo



California Regulatory Warning
WARNING: Cancer and Reproductive Harm -
www.P65Warnings.ca.gov

Barricade Tape

For hazards and restricted areas

Available in dispenser boxes - Please add DB to the end of the part number when ordering. All rolls are 3" x 1,000' and sold full case only (12 rolls per case)



Most Popular Barricade Tape

Legend and Color	Value	Contractor	Plus	Heavy Duty	Legend and Color	Value	Contractor	Plus	Heavy Duty
CAUTION	BT5058	BT1058	BT4058	BT3058	CAUTION DO NOT ENTER	BT5044	BT1044	BT4044	BT3044
DANGER	BT5057	BT1057	BT4057	BT3057	DANGER DO NOT ENTER	BT5061	BT1061	BT4061	BT3061

Full Line Barricade Tape

Legend and Color	Value	Contractor	Plus	Heavy Duty	Legend and Color	Value	Contractor	Plus	Heavy Duty	
(BLANK)	BT5080	BT1080	BT4080	BT3080	CAUTION WORK OVERHEAD	BT5055	BT1055	BT4055	BT3055	
(BLANK)	BT5067	BT1067	BT4067	BT3067	CAUTION WORKING	BT5046	BT1046	BT4046	BT3046	
	BT5031	BT1031	BT4031	BT3031	CAUTION WORKMEN ABOVE	BT5039	BT1039	BT4039	BT3039	
	-	BT10206	-	BT30206	CONFINED SPACE DO NOT ENTER	BT50201	BT10201	BT40201	BT30201	
AUTHORIZED PERSONNEL ONLY	BT5051	BT1051	BT4051	BT3051	CONSTRUCTION ZONE	BT5043	BT1043	BT4043	BT3043	
AUTHORIZED PERSONNEL ONLY	-	BT10203	-	BT30203	DANGER ASBESTOS	BT5060	BT1060	BT4060	BT3060	
	CAUTION	BT5040	BT1040	BT4040	BT3040	DANGER ASBESTOS HAZARD	BT5085	BT1085	BT4085	BT3085
CAUTION ACID HAZARD	BT5020	BT1020	BT4020	BT3020	ASBESTOS MAY CAUSE CANCER. CAUSES DAMAGE TO LUNGS. AUTHORIZED PERSONNEL ONLY.	-	BT10207	-	BT30207	
CAUTION ASBESTOS HAZARD	BT5072	BT1072	BT4072	BT3072	ASBESTOS MAY CAUSE CANCER. CAUSES DAMAGE TO LUNGS. AUTHORIZED PERSONNEL ONLY.	-	BT10208	-	BT30208	
CAUTION AUTHORIZED PERSONNEL ONLY	BT5032	BT1032	BT4032	BT3032	DANGER ASBESTOS REMOVAL	BT5086	BT1086	BT4086	BT3086	
CAUTION BIOHAZARDOUS AREA DO NOT ENTER	BT5008	BT1008	BT4008	BT3008	DANGER CONFINED SPACE	BT5071	BT1071	BT4071	BT3071	
CAUTION BURIED CABLE	BT5045	BT1045	BT4045	BT3045	DANGER CONFINED SPACE DO NOT ENTER	BT5066	BT1066	BT4066	BT3066	
CAUTION BURIED ELECTRIC LINE	BT5009	BT1009	BT4009	BT3009	RESPIRABLE CRYSTALLINE SILICA MAY CAUSE CANCER. CAUSES DAMAGE TO LUNGS. AUTHORIZED PERSONNEL ONLY.	-	BT10209	-	BT30209	
CAUTION BURIED GAS LINE	BT5052	BT1052	BT4052	BT3052		-	BT1001	-	BT3001	
CAUTION CHEMICAL CLEANING IN PROCESS	BT5007	BT1007	BT4007	BT3007	DANGER DO NOT ENTER	BT5011	BT1011	BT4011	BT3011	
CAUTION CHEMICAL HAZARD	BT5021	BT1021	BT4021	BT3021	DANGER H₂S POISONOUS GAS	BT5005	BT1005	BT4005	BT3005	
CAUTION CHEMICAL SPILL	BT5019	BT1019	BT4019	BT3019	DANGER H₂S-POISONOUS GAS	BT5002	BT1002	BT4002	BT3002	
CAUTION CONSTRUCTION AREA	BT5037	BT1037	BT4037	BT3037	DANGER HAZARDOUS AREA KEEP OUT	BT5062	BT1062	BT4062	BT3062	
CAUTION ENERGIZED AREA	BT5022	BT1022	BT4022	BT3022	DANGER HAZARDOUS MATERIAL DO NOT ENTER	BT5063	BT1063	BT4063	BT3063	
CAUTION ENTRY REQUIRES PERMISSION	BT5033	BT1033	BT4033	BT3033	DANGER HIGH VOLTAGE	BT5087	BT1087	BT4087	BT3087	
CAUTION ENTRY REQUIRES PROTECTIVE GEAR	BT5023	BT1023	BT4023	BT3023	DANGER HIGH VOLTAGE AREA	BT5064	BT1064	BT4064	BT3064	
CAUTION HARD HAT AREA	BT5024	BT1024	BT4024	BT3024	DANGER HYDROBLASTING	BT5070	BT1070	BT4070	BT3070	
CAUTION HAZARD	BT5076	BT1076	BT4076	BT3076	DANGER KEEP OUT	BT5042	BT1042	BT4042	BT3042	
CAUTION HAZARDOUS AREA	BT5088	BT1088	BT4088	BT3088	DANGER LEAD	BT5084	BT1084	BT4084	BT3084	
CAUTION HAZARDOUS MATERIAL	BT5018	BT1018	BT4018	BT3018	MICROBIAL HAZARD MAY CAUSE CANCER. CAUSES DAMAGE TO LUNGS. AUTHORIZED PERSONNEL ONLY.	-	BT10210	-	BT30210	
CAUTION HIGH VOLTAGE	BT5025	BT1025	BT4025	BT3025	RESPIRABLE CRYSTALLINE SILICA MAY CAUSE CANCER. CAUSES DAMAGE TO LUNGS. AUTHORIZED PERSONNEL ONLY.	-	BT10211	-	BT30211	
CAUTION HYDROBLASTING	BT5035	BT1035	BT4035	BT3035	SILICA DUST HAZARD Authorized Personnel Only	-	BT10212	-	BT30212	
CAUTION KEEP OUT	BT5026	BT1026	BT4026	BT3026	DO NOT ENTER	BT5089	BT1089	BT4089	BT3089	
CAUTION LEAD HAZARD	BT5038	BT1038	BT4038	BT3038	EXPLOSIVE VAPOUR	BT5006	BT1006	BT4006	BT3006	
CAUTION MEN WORKING	BT5077	BT1077	BT4077	BT3077	FIRE LINE DO NOT CROSS	BT5047	BT1047	BT4047	BT3047	
CAUTION NO PARKING	BT5027	BT1027	BT4027	BT3027	FIRE LINE - DO NOT CROSS	BT5078	BT1078	BT4078	BT3078	
CAUTION OPEN TRENCH	BT5028	BT1028	BT4028	BT3028	POLICE LINE DO NOT CROSS	BT5048	BT1048	BT4048	BT3048	
CAUTION RADIATION AREA	BT5083	BT1083	BT4083	BT3083	QUARANTINE	BT5010	BT1010	BT4010	BT3010	
CAUTION RESTRICTED AREA DO NOT ENTER	BT5034	BT1034	BT4034	BT3034	RESTRICTED AREA	BT5041	BT1041	BT4041	BT3041	
CAUTION WET CONCRETE	BT5036	BT1036	BT4036	BT3036	RESTRICTED AREA AUTHORIZED PERSONNEL ONLY	BT5090	BT1090	BT4090	BT3090	
CAUTION WET FLOOR	BT5029	BT1029	BT4029	BT3029	RESTRICTED AREA - AUTHORIZED PERSONNEL ONLY	BT5017	BT1017	BT4017	BT3017	
CAUTION WET PAINT	BT5030	BT1030	BT4030	BT3030	SHERIFF LINE DO NOT CROSS	BT5049	BT1049	BT4049	BT3049	

California Regulatory Warning
WARNING: Cancer and Reproductive Harm - www.P65Warnings.ca.gov

VALUE

Our best value thinner gauge film for general purpose usage.



CONTRACTOR

A great blend of performance and value for the contractor markets.



+PLUS

A medium thickness film built for extended stability in windy conditions.



HD HEAVY DUTY

Our thickest grade poly film for the best durability in a wide range of applications.



Spanish Barricade Tape

Legend and Color	Value	Contractor	Plus	Heavy Duty	Legend and Color	Value	Contractor	Plus	Heavy Duty
CAUTION CUIDADO	BT5059	BT1059	BT4059	BT3059	DANGER PELIGRO	BT5068	BT1068	BT4068	BT3068
CUIDADO	BT5054	BT1054	BT4054	BT3054	PELIGRO	BT5069	BT1069	BT4069	BT3069
DANGER	BT5056	BT1056	BT4056	BT3056	PRECAUCION	BT5053	BT1053	BT4053	BT3053

French Barricade Tape

Legend and Color	Value	Contractor	Plus	Heavy Duty	Legend and Color	Value	Contractor	Plus	Heavy Duty
ATTENTION DÉFENSE D'ENTRER	BT5092	BT1092	BT4092	BT3092	ESPACE RESTREINT-ENTRÉE INTERDITE	BT5015	BT1015	BT4015	BT3015
ATTENTION ENTRÉE INTERDITE	BT50204	BT10204	BT40204	BT30204	LIGNE D'INCENDIE	BT5098	BT1098	BT4098	BT3098
ATTENTION ENTRÉE INTERDITE CAUTION DO NOT ENTER	BT5014	BT1014	BT4014	BT3014	NE PAS ENTRER POLICE	BT5003	BT1003	BT4003	BT3003
ATTENTION LIGNE ÉLECTRIQUE ENFOUÏE	BT50202	BT10202	BT40202	BT30202	POLICE DÉFENSE TRAVERSER	BT5050	BT1050	BT4050	BT3050
ATTENTION TRAVAUX AU-DESSUS	BT5096	BT1096	BT4096	BT3096	POLICE DÉFENSE D'ENTRER	BT5099	BT1099	BT4099	BT3099
ATTENTION ZONE DE CONSTRUCTION CAUTION CONSTRUCTION ZONE	BT5013	BT1013	BT4013	BT3013	ZONE DE CONSTRUCTION	BT5074	BT1074	BT4074	BT3074
BARRAGE POLICIER NE PAS TRAVERSER	BT5094	BT1094	BT4094	BT3094	ZONE INTERDITE	BT5073	BT1073	BT4073	BT3073
CAUTION / ATTENTION	BT5091	BT1091	BT4091	BT3091	ZONE INTERDITE	BT5079	BT1079	BT4079	BT3079
DANGER ARRÊT	BT5097	BT1097	BT4097	BT3097	ZONE INTERDITE INCENDIE	BT5081	BT1081	BT4081	BT3081
DANGER DÉFENSE D'ENTRER	BT5095	BT1095	BT4095	BT3095	ZONE INTERDITE INCENDIE	BT5082	BT1082	BT4082	BT3082
DANGER DÉFENSE D'ENTRER	BT5012	BT1012	BT4012	BT3012	ZONE INTERDITE PERSONNEL AUTORISÉ SEULEMENT	BT5093	BT1093	BT4093	BT3093
DANGER ENTRÉE INTERDITE	BT5016	BT1016	BT4016	BT3016	DANGER ZONE STRICTEMENT INTERDITE	BT5004	BT1004	BT4004	BT3004

California Regulatory Warning
 **WARNING:** Cancer and Reproductive Harm - www.P65Warnings.ca.gov



Utility Grade Barricade Tape

Our PrimeGuard Utility Grade barricade tapes are designed to provide visual warning of buried utility lines and pipes underground. The PrimeGuard legends are printed on our thickest grade of poly film to resist fading and degrading even under the toughest conditions.

All of our industry common legends are available in both 3" x 1000' and 6" 1000' foot rolls depending on the job requirements.

All 3"x1000' rolls packaged 12 per case on a 3" core. All 6"x1000' rolls packaged 6 per case on a 3" core.

PRIMEGUARD™

3" x 1,000'

CAUTION BURIED WATER LINE BELOW

UT3301

CAUTION BURIED SEWER LINE BELOW

UT3302

CAUTION BURIED ELECTRIC LINE BELOW

UT3303

CAUTION BURIED TELEPHONE LINE BELOW

UT3304

CAUTION BURIED FIBER OPTIC LINE BELOW

UT3305

CAUTION BURIED HIGH VOLTAGE BELOW

UT3306

CAUTION BURIED GAS LINE BELOW

UT3307

CAUTION BURIED ELECTRIC LINE BELOW

UT3308

CAUTION BURIED OIL LINE BELOW

UT3309

6" x 1,000'

**CAUTION CAUTION
BURIED WATER LINE BELOW**

UT3601

**CAUTION CAUTION
BURIED SEWER LINE BELOW**

UT3602

**CAUTION CAUTION
BURIED ELECTRIC LINE BELOW**

UT3603

**CAUTION CAUTION
BURIED TELEPHONE LINE BELOW**

UT3604

**CAUTION CAUTION
BURIED FIBER OPTIC LINE BELOW**

UT3605

**CAUTION CAUTION
BURIED HIGH VOLTAGE BELOW**

UT3606

**CAUTION CAUTION
BURIED GAS LINE BELOW**

UT3607

**CAUTION CAUTION
BURIED ELECTRIC LINE BELOW**

UT3608

**CAUTION CAUTION
BURIED OIL LINE BELOW**

UT3609

California Regulatory Warning

 **WARNING:** Cancer and Reproductive Harm - www.P65Warnings.ca.gov

Reinforced Grade Barricade Tape

Our reinforced PrimeGuard barricade tape offers the ultimate in durability on the jobsite.

Printed on a material similar to that used in manufacturing sandbags, these tapes do not stretch or break under normal stress conditions. PrimeGuard reinforced tapes will keep their shape in the rain and can withstand very strong winds. Our Toughest Barricade Tape.

Currently available in both CAUTION and DANGER legends. Rolls sold in full case only, 3" x 500' 12 rolls/case.

PRIMEGUARD™

CAUTION

REBT2058

DANGER

REBT2057



California Regulatory Warning



WARNING: Cancer and Reproductive Harm - www.P65Warnings.ca.gov.

Woven Polypropylene Barricade Tape

Woven polypropylene barrier tape offers a strong, reusable product to help mark safety hazards in the workplace. This tape is made from a thick woven polypropylene scrim that will withstand high winds and offer long-term durability in outdoor applications. Material complies with UL 723, data sheet available on request.

Due to the strong nature of this product it can be reused to save cost and reduce environmental impact.

Product is available in an assortment of sizes and colors.



Stock No.	Description	Size
BTW150YB	Yellow/Black Woven Barricade Tape	3/4" x 150'
BTW250YB	Yellow/Black Woven Barricade Tape	2" x 150'
BTW267YB	Yellow/Black Woven Barricade Tape	2" x 200'
BTW150RB	Red/Black Woven Barricade Tape	3/4" x 150'
BTW250RB	Red/Black Woven Barricade Tape	2" x 150'
BTW267RB	Red/Black Woven Barricade Tape	2" x 200'

What is Reflective tape?

Flexible retroreflective material primarily used to increase nighttime visibility for safety

The material consists of retroreflective glass beads, microprisms, or encapsulated lenses sealed onto a plastic substrate. All of these different material options are used to shine light back to the light source to make people aware of potential hazards. Many different colors and degrees of reflection intensity are available for various applications.

Excellent uses for reflective tapes

- Tractor Trailers and Highway vehicles
- Fleet vehicle markings and graphics
- Property and gate markers
- Emergency equipment
- Trailers
- Bollards and railings
- Loading docks
- Ramps
- Entrances and exits
- Construction equipment
- Signs
- Low hanging hazards



HOW TO CHOOSE Reflective Tape



Engineer Grade

Entry level general purpose reflectivity (ASTM D-4956 Type I). Offers vibrant daytime visibility and reflectivity for increased awareness at night.

Flexible Vehicle Grade

This product has the same reflective properties as our standard Engineer Grade, but with added flexibility. This allows the tape to conform and adhere to curves and contours.

High Intensity Grade

High Intensity grade is an excellent choice for marking anything that requires a high level of night time visibility, with a long term life cycle. High Intensity product has a reflective value of over 8 times that of our standard engineer grade products. Intended for application on relatively flat surfaces only. Product meets or exceeds ASTM D-4956 Type III/IV.

Neonbrite Grade

Neonbrite fluorescent reflective offers the highest levels of night time reflectivity, coupled with an extremely fluorescent lime color that stands out in day time applications as well. The tape has an aggressive adhesive backing with 10 year durability. Product meets or exceeds ASTM D-4956 Type VIII. Approximately 11 times more reflective than Engineer Grade.

Conspicuity Tape

Conspicuity tape is designed to provide high visibility for road and highway vehicles. Available in Red/White versions for DOT-C2 applications, and Yellow for school bus vehicles.

Reflex Reflectors

Our reflectors are designed to meet SAE A DOT requirements and help increase visibility on trailers and other vehicles.

Correct installation procedure



Surface Preparation

It is very important that the surface the tape is being adhered to is free from all contamination such as dirt, dust, grease and oil. A combination of 50/50 alcohol and water solution is usually adequate for removing most contamination. The wiper/cloth should be changed frequently (white cloth recommended). Heavy accumulation may require more aggressive cleaning techniques.



Temperature

Temperature is a critical factor in adhesive bonding and is often over-looked. All our tape products are intended to be applied in temperatures of not less than 50°F (10°C) and not more than listed on their data sheets. In general the closer to room temperature the better the bonding.



Pressure

Tape products should be smoothed down with 15 psi of pressure or more. This will aid in adhesive "wet out" and result in better bonding.



Time

Once the tape has been applied, the adhesive bond will continue to strengthen as it has time to cure. The ambient temperature will affect this bonding time (the colder the slower), but as a general rule good bonding will not be fully achieved for 24-48 hours after the application. Full bond strength will be reached at 72 hours (70°F).



Adhesion Promoters

Some very difficult surfaces may require the use of adhesion promoters to aid in proper bonding. This would be true for low surface energy materials and very porous surfaces. Promoters should be applied per manufacturer's instructions and must be allowed to fully dry prior to tape application. For porous concrete surfaces you may want to try a Dap® Weldwood® type product for aiding in bonding. Refer to manufacturer's instructions and SDS sheet for proper handling.



Test

As with most products we highly recommend that you test a small sample of product in its intended use prior to complete installation. Some applications prove to be more difficult and require additional steps to achieve the desired results.



Support

If you would like any assistance or product recommendations, please feel free to contact us at support@incomdirect.com

Engineer Grade Reflective Tape

Looking for increased awareness? Try our line of Engineer Grade Reflective Tapes. These tapes offer vibrant daytime visibility with reflective properties for nighttime use.

All solid color tape is rated for use outdoors for a 7-year life span. Tape has an aggressive adhesive that will adhere to almost any clean, dry, smooth surface and meets ASTM D-4956 Type I.

Hazard striped products have a protective lamination to ensure the printed stripe will not wear off. Tape comes with removable release liner. This product is not intended for vehicle application.

Custom printing and conversion also available. We also offer our entire range of reflective products in large format rolls. Striped product is not intended for long-term outdoor applications.



ENGINEER
Grade

Solid Color

Size	Green	White	Red	Blue	Yellow	Orange
1" x 30'	RST110	RST111	RST112	RST113	RST114	RST115
2" x 30'	RST100	RST101	RST102	RST103	RST104	RST105
3" x 30'	RST130	RST131	RST132	RST133	RST134	RST135
4" x 30'	RST140	RST141	RST142	RST143	RST144	RST145
1" x 150'	RST511	RST521	RST531	RST541	RST551	RST561
2" x 150'	RST512	RST522	RST532	RST542	RST552	RST562
3" x 150'	RST513	RST523	RST533	RST543	RST553	RST563
4" x 150'	RST514	RST524	RST534	RST544	RST554	RST564

Hazard Stripe

Size	Red/White	Yellow/Black	Orange/White	White/Black
1" x 30'	RST117	RST116	RST119	RST1110
2" x 30'	RST107	RST106	RST109	RST1010
3" x 30'	RST137	RST136	RST139	RST1310
4" x 30'	RST147	RST146	RST149	RST1410
1" x 150'	RST571	RST581	RST591	RST5101
2" x 150'	RST572	RST582	RST592	RST5102
3" x 150'	RST573	RST583	RST593	RST5103
4" x 150'	RST574	RST584	RST594	RST5104

High Intensity Reflective Tape

Superbrite high intensity reflective is an excellent choice for marking anything that requires a high level of night time visibility for a long term life cycle. The tape has an excellent entrance angularity and high intensity micro-prismatic surface. An aggressive adhesive system will adhere to most any clean, dry surface. Intended for application on relatively flat surfaces only. Product meets or exceeds ASTM D-4956 Type III/IV. Striped product is not intended for long-term outdoor applications.

Approximately 8 times more reflective than Engineer Grade.

Superbrite

Meets ASTM D-4956 Reflectivity Type III/IV



Size	Yellow/Black	Red/White
2" x 30'	HRT230YB	HRT230RW
2" x 150'	HRT2150YB	HRT2150RW

Size	Green	White	Red	Blue	Yellow	Orange
2" x 30'	HRT230GR	HRT230WH	HRT230RD	HRT230BL	HRT230YL	HRT230OR
2" x 150'	HRT2150GR	HRT2150WH	HRT2150RD	HRT2150BL	HRT2150YL	HRT2150OR

Fluorescent Reflective Tape

Neonbrite fluorescent reflective is the newest high visibility product from INCOM. This product not only offers the highest levels of night time reflectivity, it is coupled with an extremely fluorescent lime color that stands out in day time applications as well. The tape has an aggressive adhesive backing with 10 year durability. Product meets or exceeds ASTM D-4956 Type VIII.

Approximately 11 times more reflective than Engineer Grade.

Neonbrite

Meets ASTM D-4956-99 Reflectivity Type VIII

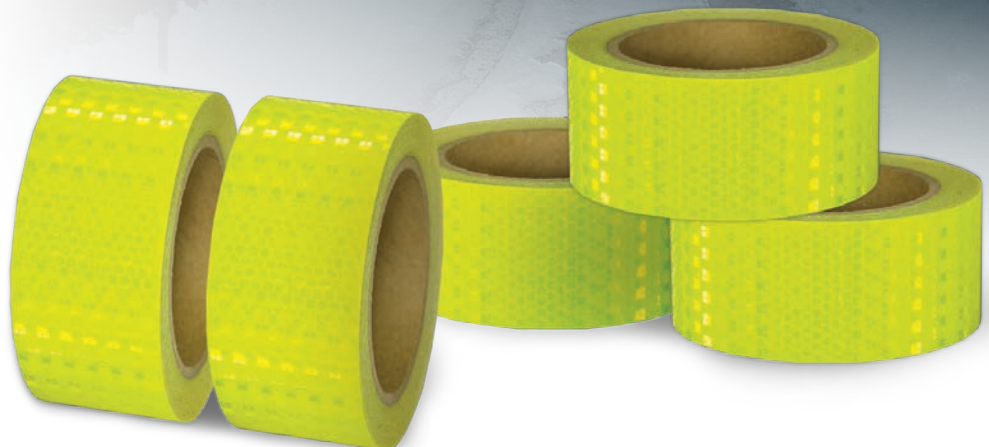

Size	Fluorescent Yellow
2" x 30'	HRT230DB
2" x 150'	HRT2150DB



Imprint with your own logo. Ask for details.

Conspicuity DOT-C2 Reflective Tape

Exceeds the requirements of NHTSA (49 CFR 571), and every strip carries the DOT-C2 certification for compliance. This conspicuity tape meets the industry's highest visibility guidance in wet or dry weather conditions with full reflective strength from distances of 1,000 feet or more. Easy to apply, our tape sticks to a variety of surfaces including fiberglass, aluminum and painted steel (please make sure surface is clean, dry and oil free before application).

Please contact customer service for information on our custom imprint program.

Stock No.	Description	Size
V57203	(Red & White) 11"/7" Pattern	2" x 150'
V57203SR	(Red & White) 11"/7" Pattern	2" x 30'
V572036	(Red & White) 6"/6" Pattern	2" x 150'
V5720WH	(Solid White)	2" x 150'

School Bus Yellow Conspicuity Tape

Our yellow school bus conspicuity reflective tape is designed for improving vehicle detection and recognition. It is a high quality, durable, microprismatic retroreflective material with a permanent pressure sensitive adhesive that offers short-term repositionability during application. The single layered construction does not require an edge sealing compound. 7 year outdoor durability on vertical exposure only. Suited for applications to most metals and painted surfaces.

Meets current application requirements for the following specifications:
 US: NHTSA FMVSS 131 (49 CFR 571)
 US: NHTSA FMVSS 217 (49 CFR 571)
 CANADA: CSA D250



Stock No.	Description	Size
V97011	Yellow School Bus Conspicuity	1" x 150'
V97012	Yellow School Bus Conspicuity	2" x 150'

Reflex Reflective Stick-On Reflectors

Our reflectors are designed with highly prismatic lenses secured to a durable transparent resin base. Produced on a clear poly liner, the rolls are easy to work with and the reflectors peel cleanly for application.

Each reflector is marked with the SAE A DOT certification. These reflectors are easy to install and are a cost effective alternative to plastic models. Meets or exceeds SAE J592 A.

Available in longer length rolls for OEM applications.



Stock No.	Description	Size
RR250AM	Amber Lens Reflectors (50 per roll)	2" x 3-1/2"
RR250RD	Red Lens Reflectors (50 per roll)	2" x 3-1/2"
RR350AM	Amber Lens Reflectors (50 per roll)	3" circle
RR350RD	Red Lens Reflectors (50 per roll)	3" circle

Highly Reflective

Hard Hat Decals

Improve the safety of your employees with our selection of high intensity reflective hard hat decals. The reflective and colorful properties of these adhesive markers will help get your employees noticed both day and night.

High Intensity product has a reflective value of over 8 times that of our standard engineer grade products. Product meets or exceeds ASTM D-4956 Type III.

Simply peel from liner and apply. Each decal kit contains the following: 16 pcs (4" x 1") per sheet Custom printing and shapes available to suit your specific applications.



Superbrite

Meets ASTM D-4956 Reflectivity Type III/IV

Stock No.	Description	Size
HHD920WH	White Reflective Decals	16 decals/sheet
HHD920RD	Red Reflective Decals	16 decals/sheet
HHD920YL	Yellow Reflective Decals	16 decals/sheet
HHD920GR	Green Reflective Decals	16 decals/sheet
HHD920BL	Blue Reflective Decals	16 decals/sheet

Reflective Kit

Hard Hat Decals

Improve the safety of your employees with our selection of shaped reflective hard hat decals. The reflective and colorful properties of these adhesive markers will help get your employees noticed both day and night.

The material is an ASTM D-4956-99 Type I reflective sheeting with a permanent adhesive. Simply peel from liner and apply.

Each decal kit contains the following:

- 2 pcs (6" x 1")
- 2 pcs (2.5" x 1")
- 1 pcs (0.75" x 1" diamond)
- 3 pcs (2" diam circles)

Custom printing and designs available to suit your specific applications.



Stock No.	Description	Qty/Pkg
HHD900WH	White Reflective Assorted Decals	5 sheets/pkg
HHD900RD	Red Reflective Assorted Decals	5 sheets/pkg
HHD900YL	Yellow Reflective Assorted Decals	5 sheets/pkg
HHD900GR	Green Reflective Assorted Decals	5 sheets/pkg
HHD900BL	Blue Reflective Assorted Decals	5 sheets/pkg
HHD900OR	Orange Reflective Assorted Decals	5 sheets/pkg

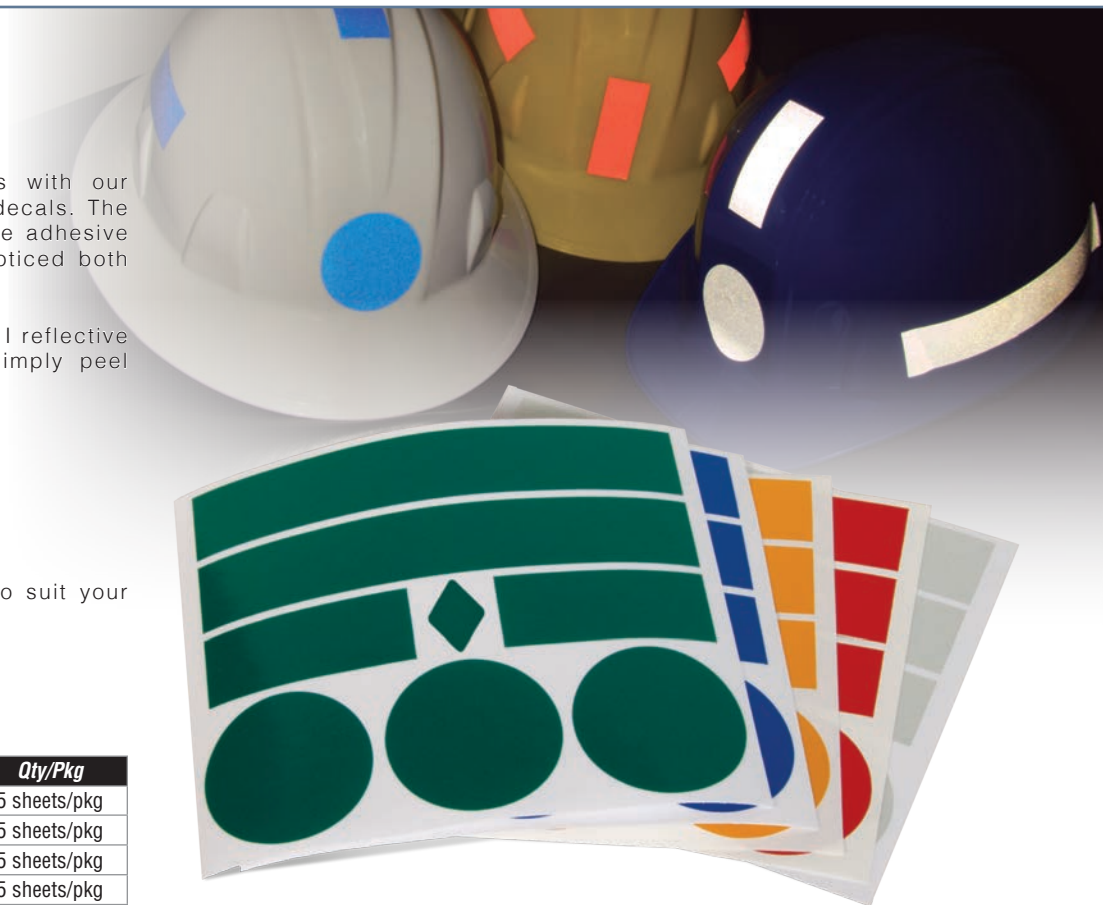

What are pipe markers?

Identify pipe contents and potential hazards

Pipe markers are an important part of safety markings in your facility. These markers help emergency responders and your staff quickly identify pipe contents and potential hazards.



Common uses for pipe & valve identification

- Mechanical Contractors
- HVAC
- Refineries
- Hospitals
- Municipal buildings
- Manufacturing facilities



ASME A13.1-2015 Designation of Marker Colors

FIRE QUENCHING FLUIDS	SAFETY RED WITH WHITE TEXT
TOXIC AND CORROSIVE FLUIDS	SAFETY ORANGE WITH BLACK TEXT
FLAMMABLE AND OXIDIZING FLUIDS	SAFETY YELLOW WITH BLACK TEXT
COMBUSTIBLE FLUIDS	SAFETY BROWN WITH WHITE TEXT
POTABLE, COOLING, BOILER FEED AND OTHER WATER	SAFETY GREEN WITH WHITE TEXT
COMPRESSED AIR	SAFETY BLUE WITH WHITE TEXT
TO BE DEFINED BY USER	SAFETY PURPLE WITH WHITE TEXT
TO BE DEFINED BY USER	SAFETY WHITE WITH BLACK TEXT
TO BE DEFINED BY USER	SAFETY GRAY WITH WHITE TEXT
TO BE DEFINED BY USER	SAFETY BLACK WITH WHITE TEXT

ASME A13.1-2015 Letter Height & Length of Marker



A	B	C
Pipe Outer Diameter	Letter Height	Length of Marker
3/4" thru 1-1/4"	1/2"	8"
1/2" thru 2"	3/4"	8"
2-1/2" thru 6"	1-1/4"	12"
8" thru 10"	2-1/2"	24"
Over 10"	3-1/2"	32"

ASME A13.1-2015 Location of Identification Markers

ASME A13.1-2015 (Section 3.1) Arrows shall be used to indicate direction of flow.

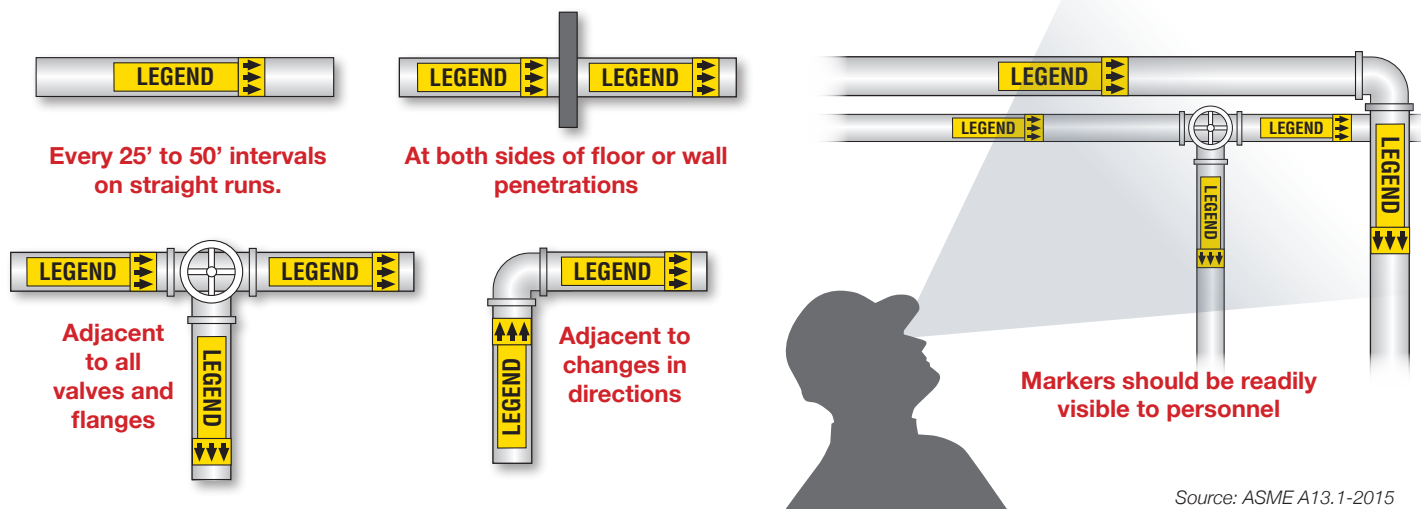

Source: ASME A13.1-2015

Adhesive Pipe Markers

Our adhesive VynMark pipe markers have a permanent adhesive backing and thick clear UV, abrasion and fade resistant coating. Markers will adhere to a wide variety of smooth clean surfaces. Must be used in conjunction with a flow direction indicator for compliance. We recommend the use of our directional flow arrow tape on page 46.

All colors meet the ANSI 535.1 and Z535.1 Safety Color Chart. Markers comply with ANSI/ASME A13.1-2015.



HOW TO ORDER MARKERS:	SELECT MARKER - PM1000	SELECT TYPE/SIZE - VA	ADD TOGETHER - PM1000VA	
Size code	Marker Size	Character Height	Diameter of Pipe	Material
VA	1" x 8"	1/2"	3/4" thru 1-1/4"	Adhesive VynMark
VB	1-1/4" x 8"	3/4"	1-1/2" thru 2"	Adhesive VynMark
VC	2" x 12"	1-1/4"	2-1/2" thru 6"	Adhesive VynMark
VD	3" x 24"	2-1/2"	8" thru 10"	Adhesive VynMark
VE	4" x 32"	3-1/2"	Over 10"	Adhesive VynMark

Snap On Style Pipe Markers

Manufactured using a rigid base stock with a UV, fade and abrasion resistant coated print.

Our coil wrap pipe markers offer an excellent way to quickly and easily mark your pipes. Simply uncoil the marker, apply to pipe and it will coil back around without having to clean or prep the pipe surface. These markers offer 360 degree viewing and have directional flow arrows included in the printing to speed installation times.

For pipe sizes up to 6" use our coiled snap on style. For pipe sizes over 6" use the strap on style that includes nylon cable ties. Snap on pipe markers in sizes 2-1/2" to 6" include an adhesive stripe for added durability applications over 120F.



Printed plastic sheet can be installed with supplied zip ties



HOW TO ORDER MARKERS:	SELECT MARKER - PM1000	SELECT TYPE/SIZE - RA	ADD TOGETHER - PM1000RA	
Size code	Character Height	Diameter of Pipe	Material	
RA	1/2"	3/4" thru 1-1/4"	Coiled Printed Plastic Sheet	
RB	3/4"	1-1/2" thru 2"	Coiled Printed Plastic Sheet	
RC	1-1/4"	2-1/2" thru 3-7/8"	Coiled Printed Plastic Sheet	
RD	1-1/4"	4" thru 6"	Coiled Printed Plastic Sheet	
RF	1-1/4"	6" thru 7-7/8"	Printed Sheet + Straps	
RG	2-1/2"	8" thru 10"	Printed Sheet + Straps	
RH	3-1/2"	Over 10"	Printed Sheet + Straps	

ACETONE	PM1001	CONDENSATE DRAIN	PM1069	GLYCOL	PM1137	LOW PRESSURE NITROGEN	PM1205	SERVICE AIR	PM1273
ACETYLENE GAS	PM1002	CONDENSATE DRAIN	PM1070	GLYCOL RETURN	PM1138	LO-PRESSURE STEAM	PM1206	SERVICE AIR	PM1274
ACETYLENE GAS	PM1003	CONDENSATE PUMP DISCHARGE	PM1071	GLYCOL RETURN	PM1139	LOW PRESSURE WATER	PM1207	SEWAGE	PM1275
ACID	PM1004	CONDENSATE PUMP DISCHARGE	PM1072	GLYCOL RETURN	PM1140	LUBE OIL	PM1208	SEWER	PM1276
ACID	PM1005	CONDENSATE RETURN	PM1073	GLYCOL SUPPLY	PM1141	MAKE-UP WATER	PM1209	SLUDGE	PM1277
ACID VENT	PM1006	CONDENSATE SUPPLY	PM1074	GLYCOL SUPPLY	PM1142	MEDICAL AIR	PM1210	SOAP	PM1278
ACID VENT	PM1007	CONDENSATE WATER	PM1075	GLYCOL SUPPLY	PM1143	MEDICAL VACUUM	PM1211	SODIUM HYDROXIDE	PM1279
ACID WASTE	PM1008	CONDENSATE WATER	PM1076	HALLON	PM1144	MILL AIR	PM1212	SODIUM HYDROXIDE	PM1280
ACID WASTE	PM1009	CONDENSATE WATER RETURN	PM1077	HEATING	PM1145	MILL WATER	PM1213	SODIUM HYPOCHLORITE	PM1281
AIR	PM1010	CONDENSATE WATER SUPPLY	PM1078	HEATING	PM1146	MIXED GAS	PM1214	SOFT WATER	PM1282
AIR	PM1011	COOLING WATER	PM1079	HEATING HOT WATER RETURN	PM1147	NATURAL GAS	PM1215	SOLVENT	PM1283
AIR	PM1012	COOLING WATER RETURN	PM1080	HEATING HOT WATER RETURN	PM1148	NATURAL GAS	PM1216	SPENT ACID	PM1284
AIR RETURN	PM1013	COOLING WATER SUPPLY	PM1081	HEATING HOT WATER SUPPLY	PM1149	NITRIC ACID	PM1217	SPENT ACID	PM1285
AIR SUPPLY	PM1014	DEIONIZED WATER	PM1082	HEATING HOT WATER SUPPLY	PM1150	NITRIC ACID	PM1218	SPRINKLER	PM1286
ALCOHOL	PM1015	DEIONIZED WATER SUPPLY	PM1083	HEATING RETURN	PM1151	NITROGEN	PM1219	SPRINKLER FIRE	PM1287
ALUM	PM1016	DIESEL FUEL	PM1084	HEATING SUPPLY	PM1152	NITROGEN	PM1220	SPRINKLER WATER	PM1288
ALUM	PM1017	DIESEL OIL	PM1085	HEATING WATER RETURN	PM1153	NITROUS OXIDE	PM1221	STEAM	PM1289
AMMONIA	PM1018	DIESEL WASTE OIL	PM1086	HEATING WATER SUPPLY	PM1154	NITROUS OXIDE	PM1222	STEAM RETURN	PM1290
AMMONIA	PM1019	DIESEL WASTE OIL	PM1087	HEATING WATER SUPPLY	PM1155	NITROUS OXIDE	PM1223	STEAM SUPPLY	PM1291
ARGON	PM1020	DISCHARGE	PM1088	HIGH PRESSURE AIR	PM1156	NON-POTABLE WATER	PM1224	STORM DRAIN	PM1292
ARGON	PM1021	DISTILLED WATER	PM1089	HIGH PRESSURE AIR	PM1157	OIL	PM1225	STORM SEWER	PM1293
ARGON	PM1022	DOMESTIC	PM1090	HIGH PRESSURE CONDENSATE	PM1158	OIL SUPPLY	PM1226	STORM WATER	PM1294
ARGON	PM1023	DOMESTIC COLD WATER	PM1091	HIGH PRESSURE GAS	PM1159	OUTSIDE AIR	PM1227	SULFUR DIOXIDE	PM1295
ASBESTOS FREE	PM1024	DOMESTIC COLD WATER RETURN	PM1092	HIGH PRESSURE GAS	PM1160	OUTSIDE AIR	PM1228	SULFUR DIOXIDE	PM1296
ASBESTOS FREE INSULATION	PM1025	DOMESTIC COLD WATER SUPPLY	PM1093	HIGH PRESSURE HOT WATER	PM1161	OXYGEN	PM1229	SULFURIC ACID	PM1297
ASBESTOS FREE INSULATION	PM1026	DOMESTIC HOT WATER	PM1094	HIGH PRESSURE HOT WATER	PM1162	OXYGEN	PM1230	SULFURIC ACID	PM1298
BACKWASH	PM1027	DOMESTIC HOT WATER	PM1095	HIGH PRESSURE NITROGEN	PM1163	OXYGEN	PM1231	SUMP PUMP DISCHARGE	PM1299
BLOWER AIR	PM1028	DOMESTIC HOT WATER RECIRCULATION	PM1096	HIGH PRESSURE STEAM	PM1164	OXYGEN	PM1232	SUPPLY	PM1300
BOILER BLOW DOWN	PM1029	DOMESTIC HOT WATER RECIRCULATION	PM1097	HIGH PRESSURE WATER	PM1166	PEROXIDE	PM1233	SUPPLY	PM1301
BOILER BLOW DOWN	PM1030	DOMESTIC HOT WATER RETURN	PM1098	HIGH PRESSURE WATER	PM1166	PEROXIDE	PM1234	SUPPLY	PM1302
BOILER DRAIN	PM1031	DOMESTIC HOT WATER RETURN	PM1099	HIGH PRESSURE NATURAL GAS	PM1167	PLANT AIR	PM1235	TANK DRAIN	PM1303
BOILER DRAIN	PM1032	DOMESTIC HOT WATER SUPPLY	PM1100	HOT	PM1167	PLANT AIR	PM1236	TEMPERED WATER	PM1304
BOILER FEED	PM1033	DOMESTIC HOT WATER SUPPLY	PM1101	HOT WATER	PM1168	PLANT WATER	PM1237	TEMPERED WATER	PM1305
BOILER FEED	PM1034	DRAIN	PM1102	HOT WATER	PM1169	PLUMBING VENT	PM1238	TOLUENE	PM1306
BOILER FEED WATER	PM1035	DRAIN	PM1103	HOT WATER RETURN	PM1170	POLYMER	PM1238	TOLUENE	PM1307
BOILER FEED WATER	PM1036	DRAIN WATER	PM1103	HOT WATER RETURN	PM1171	POLYMER SOLUTION	PM1239	TOWER WATER	PM1308
BREATHING AIR	PM1037	DRINKING WATER	PM1104	HOT WATER SUPPLY	PM1172	POTABLE	PM1240	TOWER WATER RETURN	PM1309
BRINE	PM1038	EFFLUENT	PM1105	HOT WATER SUPPLY	PM1173	POTABLE WATER	PM1241	TOWER WATER SUPPLY	PM1310
BRINE	PM1039	ELECTRIC TRACED	PM1106	HOT WATER SUPPLY	PM1173	POTABLE WATER	PM1242	TREATED WATER	PM1311
CARBON DIOXIDE	PM1040	ELECTRIC TRACED	PM1107	HYDRAULIC FLUID	PM1174	PROCESS WATER	PM1243	UTILITY WATER	PM1312
CARBON DIOXIDE	PM1041	EXHAUST	PM1108	HYDRAULIC FLUID	PM1175	PROCESS WATER	PM1244	UTILITY WATER	PM1313
CAUSTIC	PM1042	EXHAUST AIR	PM1109	HYDRAULIC LINE	PM1176	PROCESS WATER RETURN	PM1245	VACUUM	PM1314
CAUSTIC	PM1043	EXHAUST PIPE	PM1110	HYDRAULIC LINE	PM1177	PROCESS WATER SUPPLY	PM1246	VACUUM	PM1315
CAUSTIC SODA	PM1044	EXHAUST PIPE	PM1111	HYDRAULIC OIL	PM1178	PROCESS WATER SUPPLY	PM1247	VENT	PM1316
CAUSTIC SODA	PM1045	FEED	PM1112	HYDRAULIC OIL	PM1179	PROPANE GAS	PM1248	VENT	PM1317
CHEMICAL	PM1046	FEED	PM1113	HYDRAULIC SUPPLY	PM1180	PULP	PM1249	VENT	PM1318
CHEMICAL	PM1047	FEED	PM1113	HYDROCHLORIC ACID	PM1181	PUMP	PM1250	VENT	PM1318
CHEMICAL FEED	PM1048	FILTERED WATER	PM1114	HYDROCHLORIC ACID	PM1182	PUMPED CONDENSATE	PM1251	WARM WATER	PM1319
CHEMICAL FEED	PM1049	FILTRATE	PM1115	HYDROCHLORIC ACID	PM1183	RAIN WATER	PM1252	WASTE	PM1320
CHILLED WATER	PM1050	FIRE AUTO SPRINKLER	PM1116	HYDROGEN	PM1184	RAIN WATER DRAIN	PM1253	WASTE WATER	PM1321
CHILLED WATER RETURN	PM1051	FIRE MAIN	PM1117	HYDROGEN PEROXIDE	PM1185	RAW WATER	PM1254	WASTE WATER	PM1322
CHILLED WATER SUPPLY	PM1052	FIRE PROTECTION WATER	PM1118	HYDROGEN PEROXIDE	PM1186	RECIRCULATED WATER	PM1255	WATER	PM1323
CHLORINE	PM1053	FIRE SPRINKLER	PM1119	INDUSTRIAL WATER	PM1187	RECIRCULATED WATER	PM1256	WATER	PM1324
CHLORINE	PM1054	FIRE SPRINKLER WATER	PM1120	INERT GAS	PM1188	REFRIGERANT LIQUID	PM1257	WELL WATER	PM1325
CIRCULATING WATER	PM1055	FIRE WATER SYSTEM	PM1121	INERT GAS	PM1189	REFRIGERANT SUCTION	PM1258	WHITE LIQUOR	PM1326
CITY GAS	PM1056	FREON	PM1122	INSTRUMENT AIR	PM1190	REFRIGERATED LIQUID	PM1259	WHITE LIQUOR	PM1327
CITY GAS	PM1057	FREON	PM1123	INSTRUMENT AIR	PM1191	REFRIGERATED LIQUID	PM1260	WHITE LIQUOR	PM1328
CITY WATER	PM1058	FRESH WATER	PM1124	KEROSENE	PM1192	REFRIGERATION	PM1261	→	PM1329
COLD SUPPLY	PM1059	FUEL GAS	PM1125	LAB VACUUM	PM1193	RETURN	PM1262	→	PM1330
COLD WATER	PM1060	FUEL OIL	PM1126	LAB VENT	PM1194	RETURN	PM1263	→	PM1331
COLD WATER DRAIN	PM1061	FUEL OIL RETURN	PM1127	LAB WASTE	PM1195	RETURN	PM1264	→	PM1332
COLD WATER RETURN	PM1062	FUEL OIL SUPPLY	PM1128	LIQUID NITROGEN	PM1196	RETURN	PM1265	→	PM1333
COLD WATER SUPPLY	PM1063	FUEL OIL VENT	PM1129	LOW PRESSURE	PM1197	RETURN	PM1266	→	PM1334
COMPRESSED AIR	PM1064	GAS	PM1130	LOW PRESSURE AIR	PM1198	ROOF DRAIN	PM1266	→	PM1335
COMPRESSED AIR	PM1065	GAS	PM1131	LOW PRESSURE AIR	PM1199	SALT WATER	PM1267	→	PM1336
COMPRESSED AIR	PM1066	GAS	PM1132	LOW PRESSURE CONDENSATE	PM1200	SANITARY DRAIN	PM1268	→	PM1337
CONDENSATE	PM1067	GASOLINE	PM1133	LOW PRESSURE GAS	PM1201	SANITARY SEWER	PM1269	→	PM1338
CONDENSATE	PM1068	GASOLINE	PM1134	LOW PRESSURE GAS	PM1202	SANITARY VENT	PM1270	→	PM1339
		GLYCOL	PM1135	LOW PRESSURE NATURAL GAS	PM1203	SANITARY WASTE	PM1271	→	PM1340
		GLYCOL	PM1136	LOW PRESSURE NATURAL GAS	PM1204	SEAL WATER	PM1272	→	

Directional Flow Arrow Tape

Use our directional flow arrow tape to easily and effectively mark pipe flow direction. Our arrow tape is made from a durable base stock with an aggressive adhesive and clear over-lamination to protect the printed surface and offer years of service. All our banding tape has a continuous print design with no white line every foot, which allows for a professional looking installation.

All colors meet the ANSI 535.1 and Z535.1 Safety Color Chart. They also comply with ANSI / ASME A13.1 standard for pipe markings including the new colors introduced under ANSI/ ASME A13.1-2015.



Size	Blue/White	Green/White	Orange/Black	Red/White	Yellow/Black	Brown/White	Purple/White	Gray/White	Black/White	White/Black
1" x 54'	PMA101	PMA102	PMA103	PMA104	PMA105	PMA106	PMA1010	PMA1011	PMA1012	PMA109
2" x 54'	PMA201	PMA202	PMA203	PMA204	PMA205	PMA206	PMA2010	PMA2011	PMA2012	PMA209
4" x 54'	PMA401	PMA402	PMA403	PMA404	PMA405	PMA406	PMA4010	PMA4011	PMA4012	PMA409
1" x 108'	PMA151	PMA152	PMA153	PMA154	PMA155	PMA156	PMA1510	PMA1511	PMA1512	PMA159
2" x 108'	PMA251	PMA252	PMA253	PMA254	PMA255	PMA256	PMA2510	PMA2511	PMA2512	PMA259
4" x 108'	PMA451	PMA452	PMA453	PMA454	PMA455	PMA456	PMA4510	PMA4511	PMA4512	PMA459

Pipe Banding Conformable Tape

We offer a wide selection of quality pipe banding tapes. Our pipe banding tapes are made from a durable film with a rubber adhesive system that will adhere to most any clean, dry surface. The construction offers a smooth, conformable matte finish that is great for pipe banding applications. All tapes are made in a wide array of OSHA colors that meet ANSI Z535.1 and offer excellent durability and chemical resistance.

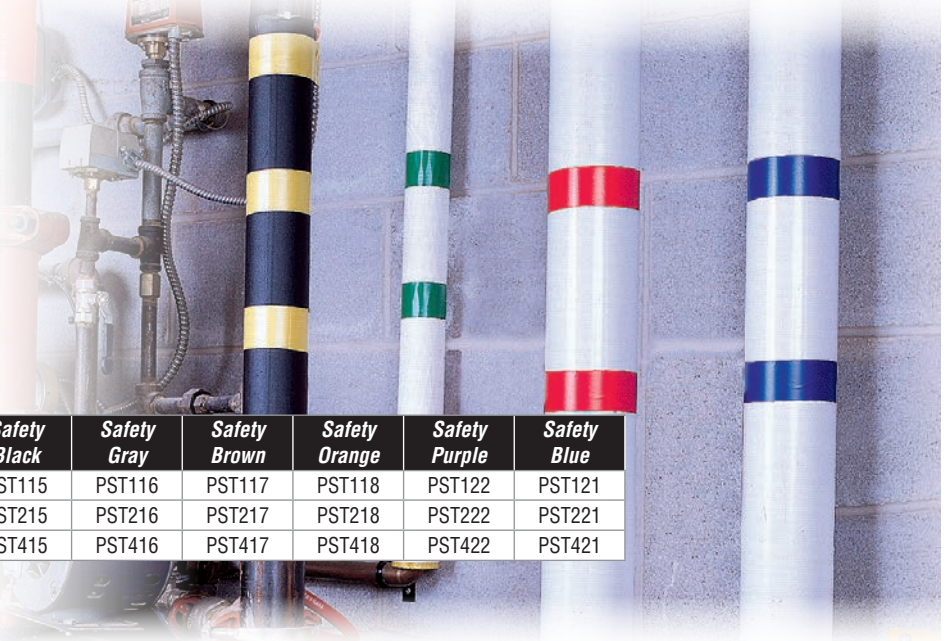

Size	Safety Yellow	Safety Green	Safety Red	Safety White	Safety Black	Safety Gray	Safety Brown	Safety Orange	Safety Purple	Safety Blue
1" x 108'	PST110	PST111	PST112	PST113	PST115	PST116	PST117	PST118	PST122	PST121
2" x 108'	PST210	PST211	PST212	PST213	PST215	PST216	PST217	PST218	PST222	PST221
4" x 108'	PST410	PST411	PST412	PST413	PST415	PST416	PST417	PST418	PST422	PST421

California Regulatory Warning
 **WARNING:** Cancer and Reproductive Harm - www.P65Warnings.ca.gov

Pipe Markers On-A-Roll

Pipe markers are an important part of safety markings in your facility. These markers easily help emergency responders and your staff quickly identify hazards and pipe contents.

Our pipe markers are made from durable adhesive backed stock with a protective overlamination. These markers are perforated every 9 inches between each legend for easy use as singles, or allowing larger strips for longer applications. Once applied to a clean, dry surface, these markers will offer a long term marking solution for your facility. Customization available.

All colors meet the ANSI 535.1 and Z535.1 Safety Color Chart. They also comply with ANSI / ASME A13.1 standard for pipe markings including the new colors introduced under ANSI/ASME A13.1-2015.

Available in 1" x 54' and 2" x 54' rolls.



ACID	PMR1005	DRAIN	PMR1102	MAKE UP WATER	PMR1209	STEAM	PMR1364
AIR	PMR1012	EXHAUST	PMR1108	MEDIUM PRESSURE STEAM	PMR1360	STEAM	PMR1289
AIR	PMR1010	FILTERED WATER	PMR1114	MEDIUM PRESSURE STEAM	PMR1361	STEAM RETURN	PMR1290
AMMONIA	PMR1018	FIRE PROTECTION WATER	PMR1118	NATURAL GAS	PMR1215	STEAM SUPPLY	PMR1365
ASBESTOS FREE INSULATION	PMR1025	FIRE SPRINKLER WATER	PMR1120	NITROGEN	PMR1219	STEAM SUPPLY	PMR1291
BOILER FEED WATER	PMR1035	FUEL OIL	PMR1126	NON-POTABLE WATER	PMR1362	STORM DRAIN	PMR1292
CARBON DIOXIDE	PMR1040	GAS	PMR1130	NON-POTABLE WATER	PMR1224	STORM WATER	PMR1294
CAUSTIC	PMR1043	GLYCOL	PMR1136	OIL	PMR1225	SUPPLY	PMR1302
CHILLED WATER	PMR1050	HEATING	PMR1145	OXYGEN	PMR1232	SUPPLY	PMR1301
CHILLED WATER RETURN	PMR1051	HEATING RETURN	PMR1354	OXYGEN	PMR1230	SUPPLY	PMR1300
CHILLED WATER SUPPLY	PMR1052	HEATING RETURN	PMR1150	PLUMBING VENT	PMR1237	TEMPERED WATER	PMR1305
CIRCULATING WATER	PMR1055	HEATING SUPPLY	PMR1355	POTABLE WATER	PMR1241	TEMPERED WATER	PMR1304
CITY WATER	PMR1058	HEATING SUPPLY	PMR1151	PROCESS WATER	PMR1244	TOWER WATER	PMR1308
COLD WATER	PMR1060	HIGH PRESSURE AIR	PMR1155	PROCESS WATER	PMR1243	TREATED WATER	PMR1311
COLD WATER RETURN	PMR1062	HIGH PRESSURE CONDENSATE	PMR1157	PROPANE GAS	PMR1363	VACUUM	PMR1315
COLD WATER SUPPLY	PMR1063	HIGH PRESSURE STEAM	PMR1356	RAIN WATER	PMR1252	VACUUM	PMR1314
COMPRESSED AIR	PMR1065	HIGH PRESSURE STEAM	PMR1163	RAW WATER	PMR1254	VENT	PMR1317
COMPRESSED AIR	PMR1064	HOT WATER	PMR1169	REFRIGERATED LIQUID	PMR1259	VENT	PMR1316
CONDENSATE	PMR1352	HOT WATER	PMR1168	REFRIGERATED SUCTION	PMR1260	WASTE	PMR1366
CONDENSATE	PMR1067	HOT WATER RETURN	PMR1171	RETURN	PMR1265	WASTE	PMR1320
CONDENSATE RETURN	PMR1353	HOT WATER RETURN	PMR1170	RETURN	PMR1264	WASTE WATER	PMR1322
CONDENSATE SUPPLY	PMR1074	HOT WATER SUPPLY	PMR1173	RETURN	PMR1262	WATER	PMR1324
CONDENSATE WATER	PMR1075	HOT WATER SUPPLY	PMR1172	RETURN	PMR1263	WATER	PMR1323
CONDENSATE WATER RETURN	PMR1076	INDUSTRIAL WATER	PMR1187	ROOF DRAIN	PMR1266	WELL WATER	PMR1325
CONDENSATE WATER SUPPLY	PMR1077	LOW PRESSURE AIR	PMR1357	SANITARY DRAIN	PMR1268	→ → → →	PMR1334
DEIONIZED WATER	PMR1081	LOW PRESSURE CONDENSATE	PMR1199	SANITARY SEWER	PMR1269	→ → → →	PMR1333
DOMESTIC COLD WATER	PMR1090	LOW PRESSURE STEAM	PMR1358	SPRINKLER FIRE	PMR1287	→ → → →	PMR1329
DOMESTIC HOT WATER	PMR1094	LOW PRESSURE STEAM	PMR1359	SPRINKLER WATER	PMR1288	→ → → →	PMR1331
DOMESTIC HOT WATER	PMR1093						

HOW TO ORDER MARKERS:		SELECT LEGEND - PMR1000	SELECT SIZE - F	ADD TOGETHER - PMR1000F	
Size code	Marker Size	Roll Length	Diameter of Pipe	Legend per Roll	
D	1" x 9"	1" x 54'	Up to 2-1/2"	72	
F	2" x 9"	2" x 54'	2-1/2" thru 4"	72	
Size Code	Marker Size	Roll Length	Diameter of Pipe	Arrows per Roll	
D	1" x 3"	1" x 54'	Up to 2-1/2"	216	
F	2" x 3"	2" x 54'	2-1/2" thru 4"	216	

Stencil Pipe Marker

Looking for a more durable Pipe Marking solution? Our Pipe Marker Stencils provide a permanent painted solution to identify your pipes. These durable and reusable stencils are easy to use and provide professional looking markings. Stencils are made with 0.020" HDPE and available in 2 stock sizes.

Custom stencils available. Call for details.



9" x 27"

For 4-1/2" to 6-1/2" diameter pipes.
1-1/4" Height letters.



11" x 45"

For 8" to 10" diameter pipes.
2-1/2" Height letters.



← ACID → SPM1004	← AIR → SPM1010	← CAUSTIC → SPM1042	← CHILLED WATER → SPM1050
← CHILLED WATER RETURN → SPM1051	← CHILLED WATER SUPPLY → SPM1052	← CITY WATER → SPM1058	← COLD WATER → SPM1060
← COMPRESSED AIR → SPM1064	← CONDENSATE → SPM1067	← CONDENSATE RETURN → SPM1073	← CONDENSATE WATER → SPM1075
← DOMESTIC COLD WATER → SPM1090	← DRAIN → SPM1101	← EXHAUST → SPM1108	← FIRE PROTECTION WATER → SPM1118
← FUEL OIL → SPM1126	← GAS → SPM1130	← HEATING → SPM1145	← HEATING RETURN → SPM1150
← HEATING SUPPLY → SPM1151	← HIGH PRESSURE CONDENSATE → SPM1157	← HIGH PRESSURE STEAM → SPM1163	← HOT WATER → SPM1168
← HOT WATER RETURN → SPM1170	← HOT WATER SUPPLY → SPM1172	← LOW-PRESSURE NITROGEN → SPM1204	← NATURAL GAS → SPM1215
← NITROGEN → SPM1219	← RETURN → SPM1262	← SANITARY SEWER → SPM1269	← SPRINKLER FIRE → SPM1287
← SPRINKLER WATER → SPM1288	← STEAM → SPM1289	← SUPPLY → SPM1300	← VACUUM → SPM1314
← VENT → SPM1316	← WATER → SPM1323	→ SPM1329	→ SPM1335

HOW TO ORDER MARKERS:	SELECT MARKER - SPM100	SELECT TYPE/SIZE - A	ADD TOGETHER - SPM100A
Size code	Marker Size	Character Height	Diameter of Pipe
A	9" x 27"	1-1/4"	2-1/2" thru 6"
B	11" x 45"	2-1/2"	8" thru 10"

Custom Engraved Plastic Valve Tags

Engraved 0.125" plastic tags offer a very durable way to mark valves and pipes. Our tags are made from a durable multi-layered plastic custom engraved with your wording or design for maximum longevity. Variable text and numbering is available on all tags. Standard colors shown below, with custom color and size options available on request.

Colors

BLACK ON YELLOW

WHITE ON RED

WHITE ON GREEN



Available in circle and square shapes 1-1/2", 2", 3" and 4"

Brass Number Tags

Consecutive numbered brass tags are a staple of the pipe and valve identification process. These 0.032" thick, tumbled, brass tags have consecutive numbers (3/8" height), stamped into the brass, then black filled for maximum durability and visibility. Available in a complete range of numbers in sets of 25. Tags are 1-1/4" diameter with 3/16" hang holes.



Stock No.	Description	Qty/Pack
NTG1	Brass Tags Numbered 1-25	25
NTG26	Brass Tags Numbered 26-50	25
NTG51	Brass Tags Numbered 51-75	25
NTG76	Brass Tags Numbered 76-100	25

California Regulatory Warning

WARNING: Cancer and Reproductive Harm - www.P65Warnings.ca.gov.

Aluminum Property Tags

Use our serially numbered property control tags for a positive identification of company assets, valves and process equipment. Made from a durable 0.040" thick aluminum with lettering and numbering stamped into the aluminum and black filled for maximum visibility. Consecutive numbering available. Tags available in two sizes with 1/8" mounting holes.



3" x 1.25"

1.9375" x 1.1875"

Valve Tag Accessories

We offer a selection of tag hanging accessories to aid in your identification project. All products are 100/pkg.

California Regulatory Warning

WARNING: Cancer and Reproductive Harm - www.P65Warnings.ca.gov.



KRG1 - Split 1" Key Ring



SHK1 - 'S' Hook



BCN4 - Beaded 4" Chain

Abatement

Temporary Hazard Signs

Help maintain a safe and compliant job site during abatement projects. These thick paper signs offer a visual warning of hazards to workers and other on-site personal. All abatement signs come in 11" x 17" size and are intended for indoor or short-term outdoor applications.

We have a wide range of chemical hazard warnings including asbestos, lead, silica and microbial. Custom wording, logos and graphics available, contact us for details.

Check with local, provincial/state and federal authorities to ensure use of proper warning identification to maintain compliance.

Packaged 100 signs per pack.



AB1003

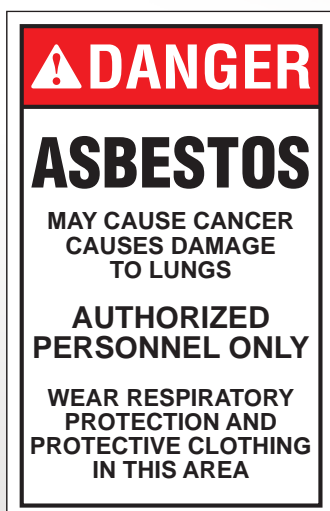

AB1000

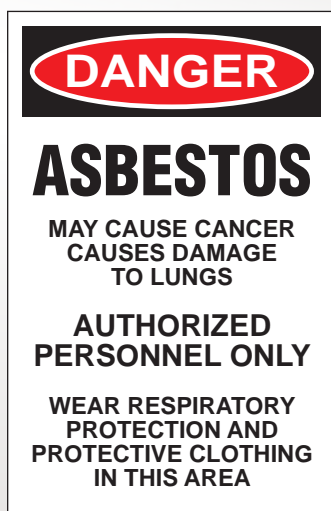

AB1001

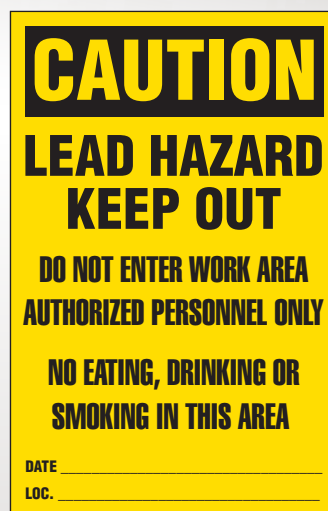

AB1002



AB1004



AB1005
English/French

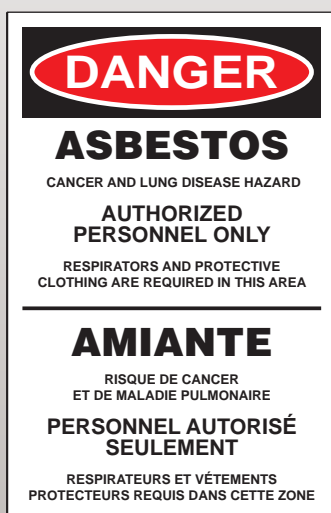

AB1006
English/French



AB1007
English/French

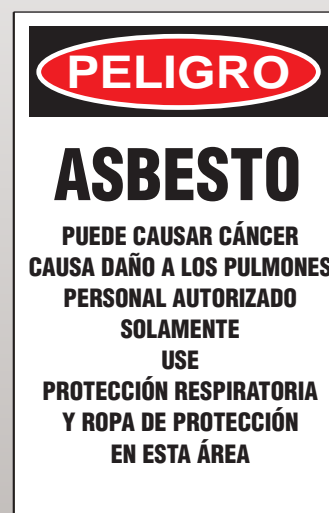

AB1008
Spanish

Abatement Tags

Aids in keeping workers safe and informed, our abatement tags offer a visual explanation of the safety hazard in bold clear text. A clear way to help promote the safe handling, storage and disposal of contaminants.

Tags are packaged 25/pkg with a standard back print on all designs. Custom wording, graphics and logos available.

Tags are available in 3.375" x 5.75" with 3/8" holes.



Back print



TG1121PT

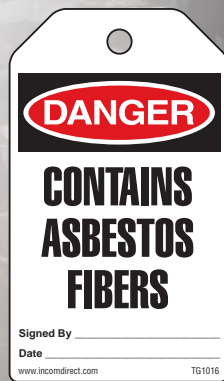

TG1016PT

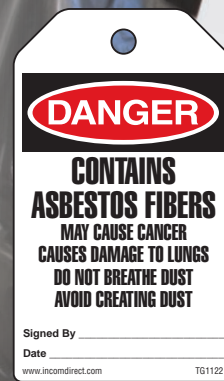

TG1122PT



Abatement Barricade Tape

We offer a wide selection of barricade tape legends and colors to aid in your abatement projects. These durable barricade tapes are all made from a thick polyethylene material and packaged 3" x 1000' per roll. We have a wide range of chemical hazard warnings including asbestos, lead, silica and microbial.

For our full line of barricade tape products, see pages 32-33. Custom wording, logos and graphics available, contact us for details.



BT10212



BT10211



BT10207

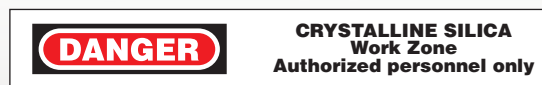

BT10209



BT10208



BT1085



BT1060



BT1072



BT1038



BT1084



BT10210



Abatement

Labels

Adhesive backed peel-n-stick labels for use in abatement and visual warning applications. These labels will adhere to a wide variety of surfaces.

Labels are sold 500/roll

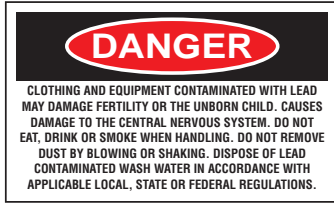

AB5000

Adhesive Paper - 5" x 3"



TT91P - Adhesive Paper - 4" x 4"

TT91V - Adhesive VynMark - 4" x 4"



AB5001

Adhesive Paper - 5" x 3"

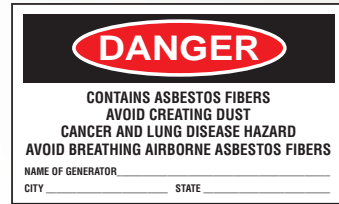

AB5002

Adhesive Paper - 5" x 3"

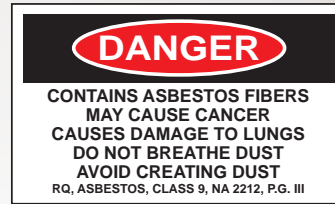

AB5003

Adhesive Paper - 5" x 3"



AB5004

Adhesive Paper - 5" x 3"



AB5005

Adhesive Paper - 5" x 3"



AB5006

Adhesive Paper - 5" x 3"



AB5007

Adhesive Paper - 5" x 3"



AB5008

Adhesive Paper - 5" x 3"

Hazardous Waste & PCB

Labels

All hazardous wastes must be properly identified according to EPA and DOT legislation. Our Hazardous Waste and PCB labels can be placed on boxes, drums, pipes and containers to clearly identify the hazard. Made from adhesive VynMark stock for added durability.

Labels are sold 500/roll

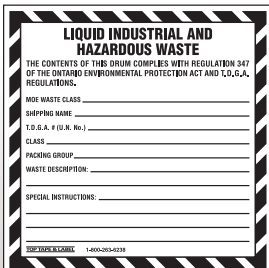

1625
6" x 6"

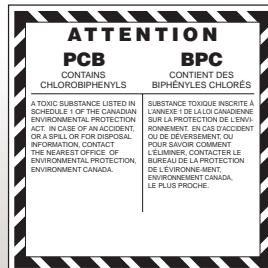

TT486
6" x 6"



1620
Federal Law
6" x 6"



1621
State & Federal Law
6" x 6"



1622
6" x 6"

Abatement

Polyethylene Tape

Our PTAK 33-series Poly Tape is designed specifically for the Abatement industry. The thick polyethylene offers a durable working surface while the rubber adhesive will bond well to most surfaces, even in lower temperatures. Ideal for use with poly sheeting in abatement applications.

Tape will also remove cleanly from most surfaces in temporary application. Tape comes with a serrated "pinked" edge for easy tearing, even with gloves on.



Stock No.	Description	Size
PTK33R48SE	Red Tape	2" x 180'
PTK33R72SE	Red Tape	3" x 180'



Heavy Duty

Polyethylene Tape

Our PTAK 36-series Poly Tape is our most durable and versatile polyethylene tape product. The heavy coat weight of adhesive allows for a high adhesion to surfaces. This tape is effective for general patching as well as heat shrink applications, and is used in truck manufacturing for isolating dissimilar metals.

Adhesive is very strong and designed for permanent applications and will leave heavy residue if removed.



Stock No.	Description	Size
PTK36C48	Clear Tape	2" x 180'
PTK36C72	Clear Tape	3" x 180'
PTK36C96	Clear Tape	4" x 180'



What are safety signs?

Effectively communicate important safety messages to employees and visitors

Hazard and safety communications are prevalent in the workplace. Safety signs help identify hazards by their use of the signal words DANGER, WARNING, CAUTION, or NOTICE. ANSI-style signs most often include specific details about the nature of the hazard, the consequence of interaction with the hazard, and avoidance procedures. Product manufacturers and facility owners in a wide array of industries use the ANSI Z535 standards in their efforts to assure a safer workplace.

The ANSI Z535 standards are often cited in as the state-of-the-art benchmark against which safety markings and their adequacy are judged.



Common uses for safety sign

- Hazard awareness
- Emergency exit points
- Chemical or gas hazards
- Physical hazards
- Safety equipment awareness
- Facility notice signs
- Personal Protective Equipment - PPE
- Traffic control
- Low light requirements
- Indoor and long term outdoor options available



Material Options

Effectively communicate important safety messages to employees and visitors with our full line of safety signs. Choose from our variety of materials for the best fit for your particular application.

Material	Thickness	Flexibility	Mounting Type	Product Use	UV Resistance
V - Adhesive VynMark with SignArmor	0.004"	Flexible	Adhesive Backed	Indoor or short term use outdoor	1 to 3 years outdoors
VL - Adhesive VynMark with UV Lamination	0.007"	Flexible	Adhesive Backed	Long term outdoor	5 to 7 years outdoors
P - Semi-Rigid Plastic with SignArmor	0.055"	Semi-Rigid	Corner Holes	Indoor or short term use outdoor	1 to 3 years outdoors
PL - Semi Rigid Plastic with UV Lamination	0.058"	Semi-Rigid	Corner Holes	Long term outdoor	5 to 7 years outdoors
A - Aluminum with SignArmor	0.040"	Rigid	Corner Holes	Indoor or short term use outdoor	1 to 3 years
AL - Aluminum with UV Lamination	0.043"	Rigid	Corner Holes	Long term outdoor	7 to 10 years
MV - Magnetic Sheeting with SignArmor	0.035"	Semi-Rigid	Magnetic	Indoor or outdoor	1 to 3 years
*VG - Glow-in-the-dark Adhesive VynMark with SignArmor	0.009"	Flexible	Adhesive Backed	Indoor	N/A
*PG - Glow-in-the-dark Semi-Rigid Plastic with SignArmor	0.045"	Semi-Rigid	Corner Holes	Indoor	N/A

*Glow-in-the-dark meets or exceeds standards: DIN 67510, ASTM E2072-14, ISO 15370, EU Marine Equipment Directive, IMO Resolution A. 752 (18) and PSPA class B

Our full line of stock safety signs are available in:

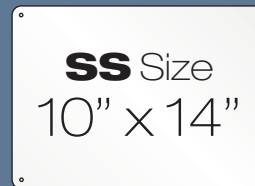

Chemical, UV, graffiti and scratch resistant

All our safety sign products come with SignArmor at no additional charge.

This coating offers many benefits to a printed sign surface including chemical, weather and graffiti resistance. The special formulation of this product improves the UV resistance of the printed sign surface which adds significantly to the overall performance of the sign. The SignArmor coating creates a difficult surface for paints, markers and chemicals to attack and allows for easy removal of graffiti using standard paint removal products while not damaging the printed sign surface.

Ensure that your sign products have the SignArmor coating for added performance.



DANGER Safety Signs

Indicate immediate danger and that special precautions are necessary. OSHA specifies that red, black and white colors are to be used for danger signs.

It is the sole responsibility of the user to determine the suitability of this product for their application, including, but not limited to, identifying the risk and its classification. When in doubt consult a qualified professional.

Choose from our variety of materials for the best fit for your particular application. Don't see the legend you need? Give us a call to see what we can do for your next sign requirement.

HOW TO ORDER:

SELECT SIGN - **SS1000** SELECT SIGN TYPE - **V** ADD TOGETHER - **SS1000V**

SIGN ARMOR			
Weather, Chemical, Abrasion & Graffiti Resistant Coating			
V	P	A	MV
Adhesive VynMark	Semi-Rigid Plastic	Aluminum	Magnetic Sheeting

OVER-LAMINATION FILM		
High Performance Outdoor UV Film		
VL	PL	AL
Adhesive VynMark	Semi Rigid Plastic	Aluminum



SA1000 (7" x 10")
SS1000 (10" x 14")
SC1000 (14" x 20")



SA1001 (7" x 10")
SS1001 (10" x 14")
SC1001 (14" x 20")



SA1002 (7" x 10")
SS1002 (10" x 14")
SC1002 (14" x 20")



SA1003 (7" x 10")
SS1003 (10" x 14")
SC1003 (14" x 20")



SA1004 (7" x 10")
SS1004 (10" x 14")
SC1004 (14" x 20")



SA1005 (7" x 10")
SS1005 (10" x 14")
SC1005 (14" x 20")



SA1006 (7" x 10")
SS1006 (10" x 14")
SC1006 (14" x 20")



SA1007 (7" x 10")
SS1007 (10" x 14")
SC1007 (14" x 20")



SA1008 (7" x 10")
SS1008 (10" x 14")
SC1008 (14" x 20")



SA1009 (7" x 10")
SS1009 (10" x 14")
SC1009 (14" x 20")



SA1010 (7" x 10")
SS1010 (10" x 14")
SC1010 (14" x 20")



SA1011 (7" x 10")
SS1011 (10" x 14")
SC1011 (14" x 20")



SA1012 (7" x 10")
SS1012 (10" x 14")
SC1012 (14" x 20")



SA1013 (7" x 10")
SS1013 (10" x 14")
SC1013 (14" x 20")



SA1014 (7" x 10")
SS1014 (10" x 14")
SC1014 (14" x 20")



SA1015 (7" x 10")
SS1015 (10" x 14")
SC1015 (14" x 20")



SA1016 (7" x 10")
SS1016 (10" x 14")
SC1016 (14" x 20")



SA1017 (7" x 10")
SS1017 (10" x 14")
SC1017 (14" x 20")



SA1018 (7" x 10")
SS1018 (10" x 14")
SC1018 (14" x 20")



SA1019 (7" x 10")
SS1019 (10" x 14")
SC1019 (14" x 20")



SA1020 (7" x 10")
SS1020 (10" x 14")
SC1020 (14" x 20")



SA1021 (7" x 10")
SS1021 (10" x 14")
SC1021 (14" x 20")



SA1022 (7" x 10")
SS1022 (10" x 14")
SC1022 (14" x 20")



SA1023 (7" x 10")
SS1023 (10" x 14")
SC1023 (14" x 20")



SA1024 (7" x 10")
SS1024 (10" x 14")
SC1024 (14" x 20")



SA1025 (7" x 10")
SS1025 (10" x 14")
SC1025 (14" x 20")



SA1026 (7" x 10")
SS1026 (10" x 14")
SC1026 (14" x 20")



SA1027 (7" x 10")
SS1027 (10" x 14")
SC1027 (14" x 20")



SA1028 (7" x 10")
SS1028 (10" x 14")
SC1028 (14" x 20")



SA1029 (7" x 10")
SS1029 (10" x 14")
SC1029 (14" x 20")



SA1030 (7" x 10")
SS1030 (10" x 14")
SC1030 (14" x 20")



SA1031 (7" x 10")
SS1031 (10" x 14")
SC1031 (14" x 20")



SA1032 (7" x 10")
SS1032 (10" x 14")
SC1032 (14" x 20")



SA1033 (7" x 10")
SS1033 (10" x 14")
SC1033 (14" x 20")



SA1034 (7" x 10")
SS1034 (10" x 14")
SC1034 (14" x 20")

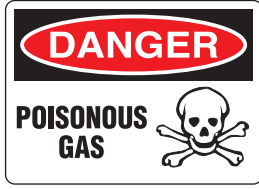

SA1035 (7" x 10")
SS1035 (10" x 14")
SC1035 (14" x 20")



SA1036 (7" x 10")
SS1036 (10" x 14")
SC1036 (14" x 20")



SA1037 (7" x 10")
SS1037 (10" x 14")
SC1037 (14" x 20")



SA1038 (7" x 10")
SS1038 (10" x 14")
SC1038 (14" x 20")



SA1039 (7" x 10")
SS1039 (10" x 14")
SC1039 (14" x 20")



SA1040 (7" x 10")
SS1040 (10" x 14")
SC1040 (14" x 20")



SA1041 (7" x 10")
SS1041 (10" x 14")
SC1041 (14" x 20")



SA1042 (7" x 10")
SS1042 (10" x 14")
SC1042 (14" x 20")

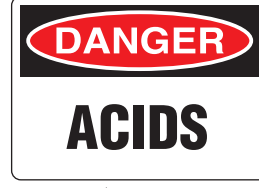

SA1043 (7" x 10")
SS1043 (10" x 14")
SC1043 (14" x 20")



SA1044 (7" x 10")
SS1044 (10" x 14")
SC1044 (14" x 20")



SA1045 (7" x 10")
SS1045 (10" x 14")
SC1045 (14" x 20")

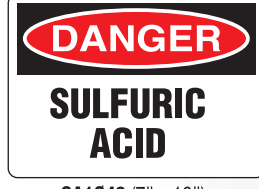

SA1046 (7" x 10")
SS1046 (10" x 14")
SC1046 (14" x 20")

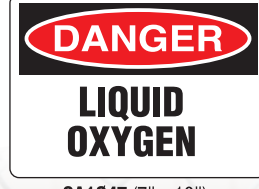

SA1047 (7" x 10")
SS1047 (10" x 14")
SC1047 (14" x 20")

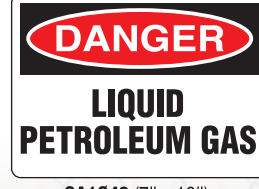

SA1048 (7" x 10")
SS1048 (10" x 14")
SC1048 (14" x 20")



SA1049 (7" x 10")
SS1049 (10" x 14")
SC1049 (14" x 20")



SA1050 (7" x 10")
SS1050 (10" x 14")
SC1050 (14" x 20")



SA1051 (7" x 10")
SS1051 (10" x 14")
SC1051 (14" x 20")



SA1052 (7" x 10")
SS1052 (10" x 14")
SC1052 (14" x 20")



SA1053 (7" x 10")
SS1053 (10" x 14")
SC1053 (14" x 20")



DANGER

ACID
WEAR PROPER PROTECTION

SA1054 (7" x 10")
SS1054 (10" x 14")
SC1054 (14" x 20")

DANGER

ARGON

SA1055 (7" x 10")
SS1055 (10" x 14")
SC1055 (14" x 20")

DANGER

HYDROGEN

SA1056 (7" x 10")
SS1056 (10" x 14")
SC1056 (14" x 20")

DANGER

ACETYLENE

SA1057 (7" x 10")
SS1057 (10" x 14")
SC1057 (14" x 20")

DANGER

PESTICIDE STORAGE AREA

SA1058 (7" x 10")
SS1058 (10" x 14")
SC1058 (14" x 20")

DANGER

PESTICIDE STORAGE AREA
ALL UNAUTHORIZED PERSONS
KEEP OUT
FIRE MAY CAUSE TOXIC FUMES

SA1059 (7" x 10")
SS1059 (10" x 14")
SC1059 (14" x 20")

DANGER

CHEMICAL WASTE STORAGE AREA
UNAUTHORIZED PERSONS
KEEP OUT

SA1060 (7" x 10")
SS1060 (10" x 14")
SC1060 (14" x 20")

DANGER

CHEMICAL STORAGE

SA1061 (7" x 10")
SS1061 (10" x 14")
SC1061 (14" x 20")

DANGER

HAZARDOUS CHEMICALS

SA1062 (7" x 10")
SS1062 (10" x 14")
SC1062 (14" x 20")

DANGER

ACID 

SA1063 (7" x 10")
SS1063 (10" x 14")
SC1063 (14" x 20")

DANGER

CAUSTIC 

SA1064 (7" x 10")
SS1064 (10" x 14")
SC1064 (14" x 20")

DANGER

CAUSTIC
WEAR PROTECTIVE EQUIPMENT

SA1065 (7" x 10")
SS1065 (10" x 14")
SC1065 (14" x 20")

DANGER

NO SMOKING 

SA1066 (7" x 10")
SS1066 (10" x 14")
SC1066 (14" x 20")

DANGER

NO SMOKING BEYOND THIS POINT 

SA1067 (7" x 10")
SS1067 (10" x 14")
SC1067 (14" x 20")

DANGER

NO SMOKING IN THIS AREA 

SA1068 (7" x 10")
SS1068 (10" x 14")
SC1068 (14" x 20")

DANGER

NO SMOKING OXYGEN IN USE 

SA1069 (7" x 10")
SS1069 (10" x 14")
SC1069 (14" x 20")

DANGER

FUEL STORAGE NO SMOKING 

SA1070 (7" x 10")
SS1070 (10" x 14")
SC1070 (14" x 20")

DANGER

FLAMMABLE MATERIAL NO SMOKING 

SA1071 (7" x 10")
SS1071 (10" x 14")
SC1071 (14" x 20")

DANGER

FLAMMABLE MATERIAL NO SMOKING WITHIN FEET 

SA1072 (7" x 10")
SS1072 (10" x 14")
SC1072 (14" x 20")

DANGER

NO SMOKING OR OPEN LIGHTS WITHIN FEET 

SA1073 (7" x 10")
SS1073 (10" x 14")
SC1073 (14" x 20")

DANGER

NO SMOKING NO OPEN FLAMES NO SPARKS  

SA1074 (7" x 10")
SS1074 (10" x 14")
SC1074 (14" x 20")

DANGER

PROPANE NO SMOKING OR OPEN FLAME  

SA1075 (7" x 10")
SS1075 (10" x 14")
SC1075 (14" x 20")

DANGER

CANCER HAZARD AUTHORIZED PERSONNEL ONLY NO SMOKING OR EATING  

SA1076 (7" x 10")
SS1076 (10" x 14")
SC1076 (14" x 20")

DANGER

DO NOT SMOKE, EAT OR DRINK IN THIS AREA  

SA1077 (7" x 10")
SS1077 (10" x 14")
SC1077 (14" x 20")

DANGER

CANCER SUSPECT AGENT AUTHORIZED PERSONNEL ONLY NO SMOKING OR EATING  

SA1078 (7" x 10")
SS1078 (10" x 14")
SC1078 (14" x 20")

DANGER

LP GAS STORAGE NO SMOKING OR OPEN FLAMES WITHIN 50 FT.

SA1079 (7" x 10")
SS1079 (10" x 14")
SC1079 (14" x 20")

DANGER

CONTAINS ASBESTOS FIBERS AVOID CREATING DUST CANCER AND LUNG DISEASE HAZARD

SA1080 (7" x 10")
SS1080 (10" x 14")
SC1080 (14" x 20")

DANGER

DO NOT BURN OR WELD ON THIS VESSEL

SA1081 (7" x 10")
SS1081 (10" x 14")
SC1081 (14" x 20")

DANGER

HIGH PRESSURE GAS LINE

SA1082 (7" x 10")
SS1082 (10" x 14")
SC1082 (14" x 20")

DANGER

HIGH PRESSURE LINE

SA1083 (7" x 10")
SS1083 (10" x 14")
SC1083 (14" x 20")

DANGER

CONFINED SPACE ENTER BY PERMIT ONLY

SA1084 (7" x 10")
SS1084 (10" x 14")
SC1084 (14" x 20")

DANGER

CONFINED SPACE DO NOT ENTER WITHOUT PERMIT

SA1085 (7" x 10")
SS1085 (10" x 14")
SC1085 (14" x 20")

DANGER

CONFINED SPACE HAZARDOUS ATMOSPHERE DO NOT ENTER WITHOUT PERMIT

SA1086 (7" x 10")
SS1086 (10" x 14")
SC1086 (14" x 20")

DANGER

CONFINED SPACE AIR SUPPLIED RESPIRATOR REQUIRED

SA1087 (7" x 10")
SS1087 (10" x 14")
SC1087 (14" x 20")

DANGER

CONFINED SPACE AIR-SUPPLIED RESPIRATOR MUST BE WORN IN THIS AREA

SA1088 (7" x 10")
SS1088 (10" x 14")
SC1088 (14" x 20")



SA1089 (7" x 10")
SS1089 (10" x 14")
SC1089 (14" x 20")



SA1090 (7" x 10")
SS1090 (10" x 14")
SC1090 (14" x 20")



SA1091 (7" x 10")
SS1091 (10" x 14")
SC1091 (14" x 20")



SA1092 (7" x 10")
SS1092 (10" x 14")
SC1092 (14" x 20")



SA1093 (7" x 10")
SS1093 (10" x 14")
SC1093 (14" x 20")



SA1094 (7" x 10")
SS1094 (10" x 14")
SC1094 (14" x 20")



SA1095 (7" x 10")
SS1095 (10" x 14")
SC1095 (14" x 20")



SA1096 (7" x 10")
SS1096 (10" x 14")
SC1096 (14" x 20")



SA1097 (7" x 10")
SS1097 (10" x 14")
SC1097 (14" x 20")



SA1098 (7" x 10")
SS1098 (10" x 14")
SC1098 (14" x 20")



SA1099 (7" x 10")
SS1099 (10" x 14")
SC1099 (14" x 20")



SA1100 (7" x 10")
SS1100 (10" x 14")
SC1100 (14" x 20")



SA1101 (7" x 10")
SS1101 (10" x 14")
SC1101 (14" x 20")



SA1102 (7" x 10")
SS1102 (10" x 14")
SC1102 (14" x 20")



SA1103 (7" x 10")
SS1103 (10" x 14")
SC1103 (14" x 20")



SA1104 (7" x 10")
SS1104 (10" x 14")
SC1104 (14" x 20")



SA1105 (7" x 10")
SS1105 (10" x 14")
SC1105 (14" x 20")



SA1106 (7" x 10")
SS1106 (10" x 14")
SC1106 (14" x 20")



SA1107 (7" x 10")
SS1107 (10" x 14")
SC1107 (14" x 20")

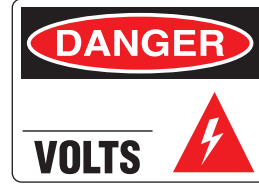

SA1108 (7" x 10")
SS1108 (10" x 14")
SC1108 (14" x 20")



SA1109 (7" x 10")
SS1109 (10" x 14")
SC1109 (14" x 20")



SA1110 (7" x 10")
SS1110 (10" x 14")
SC1110 (14" x 20")



SA1111 (7" x 10")
SS1111 (10" x 14")
SC1111 (14" x 20")



SA1112 (7" x 10")
SS1112 (10" x 14")
SC1112 (14" x 20")



SA1113 (7" x 10")
SS1113 (10" x 14")
SC1113 (14" x 20")





SA1114 (7" x 10")
SS1114 (10" x 14")
SC1114 (14" x 20")



SA1115 (7" x 10")
SS1115 (10" x 14")
SC1115 (14" x 20")



SA1116 (7" x 10")
SS1116 (10" x 14")
SC1116 (14" x 20")

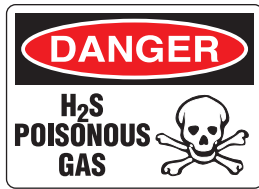

SA1117 (7" x 10")
SS1117 (10" x 14")
SC1117 (14" x 20")



SA1118 (7" x 10")
SS1118 (10" x 14")
SC1118 (14" x 20")



SA1119 (7" x 10")
SS1119 (10" x 14")
SC1119 (14" x 20")



SA1120 (7" x 10")
SS1120 (10" x 14")
SC1120 (14" x 20")



SA1121 (7" x 10")
SS1121 (10" x 14")
SC1121 (14" x 20")



SA1122 (7" x 10")
SS1122 (10" x 14")
SC1122 (14" x 20")



SA1123 (7" x 10")
SS1123 (10" x 14")
SC1123 (14" x 20")



SA1124 (7" x 10")
SS1124 (10" x 14")
SC1124 (14" x 20")



SA1125 (7" x 10")
SS1125 (10" x 14")
SC1125 (14" x 20")



SA1126 (7" x 10")
SS1126 (10" x 14")
SC1126 (14" x 20")



SA1127 (7" x 10")
SS1127 (10" x 14")
SC1127 (14" x 20")



SA1128 (7" x 10")
SS1128 (10" x 14")
SC1128 (14" x 20")



SA1129 (7" x 10")
SS1129 (10" x 14")
SC1129 (14" x 20")



SA1130 (7" x 10")
SS1130 (10" x 14")
SC1130 (14" x 20")

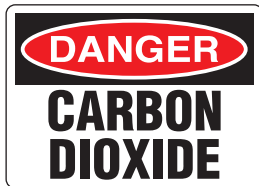

SA1131 (7" x 10")
SS1131 (10" x 14")
SC1131 (14" x 20")



SA1132 (7" x 10")
SS1132 (10" x 14")
SC1132 (14" x 20")



SA1133 (7" x 10")
SS1133 (10" x 14")
SC1133 (14" x 20")



SA1134 (7" x 10")
SS1134 (10" x 14")
SC1134 (14" x 20")



SA1135 (7" x 10")
SS1135 (10" x 14")
SC1135 (14" x 20")



SA1136 (7" x 10")
SS1136 (10" x 14")
SC1136 (14" x 20")



SA1137 (7" x 10")
SS1137 (10" x 14")
SC1137 (14" x 20")



SA1138 (7" x 10")
SS1138 (10" x 14")
SC1138 (14" x 20")



SA1139 (7" x 10")
SS1139 (10" x 14")
SC1139 (14" x 20")



SA1140 (7" x 10")
SS1140 (10" x 14")
SC1140 (14" x 20")



SA1141 (7" x 10")
SS1141 (10" x 14")
SC1141 (14" x 20")



SA1142 (7" x 10")
SS1142 (10" x 14")
SC1142 (14" x 20")



SA1143 (7" x 10")
SS1143 (10" x 14")
SC1143 (14" x 20")



SA1144 (7" x 10")
SS1144 (10" x 14")
SC1144 (14" x 20")



SA1145 (7" x 10")
SS1145 (10" x 14")
SC1145 (14" x 20")



SA1146 (7" x 10")
SS1146 (10" x 14")
SC1146 (14" x 20")



SA1147 (7" x 10")
SS1147 (10" x 14")
SC1147 (14" x 20")



SA1148 (7" x 10")
SS1148 (10" x 14")
SC1148 (14" x 20")



SA1149 (7" x 10")
SS1149 (10" x 14")
SC1149 (14" x 20")



SA1150 (7" x 10")
SS1150 (10" x 14")
SC1150 (14" x 20")



SA1151 (7" x 10")
SS1151 (10" x 14")
SC1151 (14" x 20")



SA1152 (7" x 10")
SS1152 (10" x 14")
SC1152 (14" x 20")



SA1153 (7" x 10")
SS1153 (10" x 14")
SC1153 (14" x 20")



SA1154 (7" x 10")
SS1154 (10" x 14")
SC1154 (14" x 20")



SA1155 (7" x 10")
SS1155 (10" x 14")
SC1155 (14" x 20")



SA1156 (7" x 10")
SS1156 (10" x 14")
SC1156 (14" x 20")



SA1157 (7" x 10")
SS1157 (10" x 14")
SC1157 (14" x 20")



SA1158 (7" x 10")
SS1158 (10" x 14")
SC1158 (14" x 20")



SA1159 (7" x 10")
SS1159 (10" x 14")
SC1159 (14" x 20")



SA1160 (7" x 10")
SS1160 (10" x 14")
SC1160 (14" x 20")



SA1161 (7" x 10")
SS1161 (10" x 14")
SC1161 (14" x 20")



SA1162 (7" x 10")
SS1162 (10" x 14")
SC1162 (14" x 20")



SA1163 (7" x 10")
SS1163 (10" x 14")
SC1163 (14" x 20")



SA1164 (7" x 10")
SS1164 (10" x 14")
SC1164 (14" x 20")



SA1165 (7" x 10")
SS1165 (10" x 14")
SC1165 (14" x 20")



SA1166 (7" x 10")
SS1166 (10" x 14")
SC1166 (14" x 20")



SA1167 (7" x 10")
SS1167 (10" x 14")
SC1167 (14" x 20")



WARNING Safety Signs

It is the sole responsibility of the user to determine the suitability of this product for their application, including, but not limited to, identifying the risk and its classification. When in doubt consult a qualified professional.

Choose from our variety of materials for the best fit for your particular application. Don't see the legend you need? Give us a call to see what we can do for your next sign requirement.

HOW TO ORDER:

SELECT SIGN - **SS3000** SELECT SIGN TYPE - **V** ADD TOGETHER - **SS3000V**

SIGN ARMOR			
Weather, Chemical, Abrasion & Graffiti Resistant Coating			
V	P	A	MV
Adhesive VynMark	Semi-Rigid Plastic	Aluminum	Magnetic Sheeting

OVER-LAMINATION FILM		
High Performance Outdoor UV Film		
VL	PL	AL
Adhesive VynMark	Semi Rigid Plastic	Aluminum



SA3000 (7" x 10")
SS3000 (10" x 14")
SC3000 (14" x 20")



SA3001 (7" x 10")
SS3001 (10" x 14")
SC3001 (14" x 20")



SA3002 (7" x 10")
SS3002 (10" x 14")
SC3002 (14" x 20")



SA3003 (7" x 10")
SS3003 (10" x 14")
SC3003 (14" x 20")



SA3004 (7" x 10")
SS3004 (10" x 14")
SC3004 (14" x 20")



SA3005 (7" x 10")
SS3005 (10" x 14")
SC3005 (14" x 20")



SA3006 (7" x 10")
SS3006 (10" x 14")
SC3006 (14" x 20")



SA3007 (7" x 10")
SS3007 (10" x 14")
SC3007 (14" x 20")



SA3008 (7" x 10")
SS3008 (10" x 14")
SC3008 (14" x 20")



SA3009 (7" x 10")
SS3009 (10" x 14")
SC3009 (14" x 20")



SA3010 (7" x 10")
SS3010 (10" x 14")
SC3010 (14" x 20")



SA3011 (7" x 10")
SS3011 (10" x 14")
SC3011 (14" x 20")



SA3012 (7" x 10")
SS3012 (10" x 14")
SC3012 (14" x 20")



SA3013 (7" x 10")
SS3013 (10" x 14")
SC3013 (14" x 20")



SA3014 (7" x 10")
SS3014 (10" x 14")
SC3014 (14" x 20")



SA3015 (7" x 10")
SS3015 (10" x 14")
SC3015 (14" x 20")



SA3016 (7" x 10")
SS3016 (10" x 14")
SC3016 (14" x 20")



SA3017 (7" x 10")
SS3017 (10" x 14")
SC3017 (14" x 20")



SA3018 (7" x 10")
SS3018 (10" x 14")
SC3018 (14" x 20")



SA3019 (7" x 10")
SS3019 (10" x 14")
SC3019 (14" x 20")



SA3020 (7" x 10")
SS3020 (10" x 14")
SC3020 (14" x 20")



SA3021 (7" x 10")
SS3021 (10" x 14")
SC3021 (14" x 20")



SA3022 (7" x 10")
SS3022 (10" x 14")
SC3022 (14" x 20")



SA3023 (7" x 10")
SS3023 (10" x 14")
SC3023 (14" x 20")



SA3024 (7" x 10")
SS3024 (10" x 14")
SC3024 (14" x 20")



SA3025 (7" x 10")
SS3025 (10" x 14")
SC3025 (14" x 20")



SA3026 (7" x 10")
SS3026 (10" x 14")
SC3026 (14" x 20")



SA3027 (7" x 10")
SS3027 (10" x 14")
SC3027 (14" x 20")



SA3028 (7" x 10")
SS3028 (10" x 14")
SC3028 (14" x 20")



SA3029 (7" x 10")
SS3029 (10" x 14")
SC3029 (14" x 20")



SA3030 (7" x 10")
SS3030 (10" x 14")
SC3030 (14" x 20")



SA3031 (7" x 10")
SS3031 (10" x 14")
SC3031 (14" x 20")



SA3032 (7" x 10")
SS3032 (10" x 14")
SC3032 (14" x 20")



SA3033 (7" x 10")
SS3033 (10" x 14")
SC3033 (14" x 20")



SA3034 (7" x 10")
SS3034 (10" x 14")
SC3034 (14" x 20")



SA3035 (7" x 10")
SS3035 (10" x 14")
SC3035 (14" x 20")



SA3036 (7" x 10")
SS3036 (10" x 14")
SC3036 (14" x 20")



SA3037 (7" x 10")
SS3037 (10" x 14")
SC3037 (14" x 20")



SA3038 (7" x 10")
SS3038 (10" x 14")
SC3038 (14" x 20")



SA3039 (7" x 10")
SS3039 (10" x 14")
SC3039 (14" x 20")



SA3040 (7" x 10")
SS3040 (10" x 14")
SC3040 (14" x 20")



SA3041 (7" x 10")
SS3041 (10" x 14")
SC3041 (14" x 20")



SA3042 (7" x 10")
SS3042 (10" x 14")
SC3042 (14" x 20")



SA3043 (7" x 10")
SS3043 (10" x 14")
SC3043 (14" x 20")



SA3044 (7" x 10")
SS3044 (10" x 14")
SC3044 (14" x 20")



SA3045 (7" x 10")
SS3045 (10" x 14")
SC3045 (14" x 20")



SA3046 (7" x 10")
SS3046 (10" x 14")
SC3046 (14" x 20")



SA3047 (7" x 10")
SS3047 (10" x 14")
SC3047 (14" x 20")



SA3048 (7" x 10")
SS3048 (10" x 14")
SC3048 (14" x 20")



SA3049 (7" x 10")
SS3049 (10" x 14")
SC3049 (14" x 20")



SA3050 (7" x 10")
SS3050 (10" x 14")
SC3050 (14" x 20")



SA3051 (7" x 10")
SS3051 (10" x 14")
SC3051 (14" x 20")



SA3052 (7" x 10")
SS3052 (10" x 14")
SC3052 (14" x 20")



SA3053 (7" x 10")
SS3053 (10" x 14")
SC3053 (14" x 20")



SA3054 (7" x 10")
SS3054 (10" x 14")
SC3054 (14" x 20")



SA3055 (7" x 10")
SS3055 (10" x 14")
SC3055 (14" x 20")



SA3056 (7" x 10")
SS3056 (10" x 14")
SC3056 (14" x 20")



SA3057 (7" x 10")
SS3057 (10" x 14")
SC3057 (14" x 20")

CAUTION Safety Signs

Warn against potential hazards or caution against unsafe practices. OSHA specifies that caution signs must have a yellow background and black panel with yellow letters. All letters used against the yellow background must be black.

It is the sole responsibility of the user to determine the suitability of this product for their application, including, but not limited to, identifying the risk and its classification. When in doubt consult a qualified professional.

Choose from our variety of materials for the best fit for your particular application. Don't see the legend you need? Give us a call to see what we can do for your next sign requirement.

HOW TO ORDER:

SELECT SIGN - **SS2000** SELECT SIGN TYPE - **V** ADD TOGETHER. - **SS2000V**

SIGN ARMOR			
Weather, Chemical, Abrasion & Graffiti Resistant Coating			
V	P	A	MV
Adhesive VynMark	Semi-Rigid Plastic	Aluminum	Magnetic Sheeting

OVER-LAMINATION FILM		
High Performance Outdoor UV Film		
VL	PL	AL
Adhesive VynMark	Semi Rigid Plastic	Aluminum



SA2000 (7" x 10")
SS2000 (10" x 14")
SC2000 (14" x 20")



SA2001 (7" x 10")
SS2001 (10" x 14")
SC2001 (14" x 20")



SA2002 (7" x 10")
SS2002 (10" x 14")
SC2002 (14" x 20")



SA2003 (7" x 10")
SS2003 (10" x 14")
SC2003 (14" x 20")



SA2004 (7" x 10")
SS2004 (10" x 14")
SC2004 (14" x 20")



SA2005 (7" x 10")
SS2005 (10" x 14")
SC2005 (14" x 20")



SA2006 (7" x 10")
SS2006 (10" x 14")
SC2006 (14" x 20")



SA2007 (7" x 10")
SS2007 (10" x 14")
SC2007 (14" x 20")



SA2008 (7" x 10")
SS2008 (10" x 14")
SC2008 (14" x 20")



SA2009 (7" x 10")
SS2009 (10" x 14")
SC2009 (14" x 20")



SA2010 (7" x 10")
SS2010 (10" x 14")
SC2010 (14" x 20")



SA2011 (7" x 10")
SS2011 (10" x 14")
SC2011 (14" x 20")



SA2012 (7" x 10")
SS2012 (10" x 14")
SC2012 (14" x 20")



SA2013 (7" x 10")
SS2013 (10" x 14")
SC2013 (14" x 20")



SA2014 (7" x 10")
SS2014 (10" x 14")
SC2014 (14" x 20")



SA2015 (7" x 10")
SS2015 (10" x 14")
SC2015 (14" x 20")



SA2016 (7" x 10")
SS2016 (10" x 14")
SC2016 (14" x 20")



SA2017 (7" x 10")
SS2017 (10" x 14")
SC2017 (14" x 20")



SA2018 (7" x 10")
SS2018 (10" x 14")
SC2018 (14" x 20")



SA2019 (7" x 10")
SS2019 (10" x 14")
SC2019 (14" x 20")



SA2020 (7" x 10")
SS2020 (10" x 14")
SC2020 (14" x 20")



SA2021 (7" x 10")
SS2021 (10" x 14")
SC2021 (14" x 20")



SA2022 (7" x 10")
SS2022 (10" x 14")
SC2022 (14" x 20")



SA2023 (7" x 10")
SS2023 (10" x 14")
SC2023 (14" x 20")



SA2024 (7" x 10")
SS2024 (10" x 14")
SC2024 (14" x 20")



CAUTION
STAY BACK

FT

SA2025 (7" x 10")
 SS2025 (10" x 14")
 SC2025 (14" x 20")

CAUTION
OPEN DOOR
SLOWLY

SA2026 (7" x 10")
 SS2026 (10" x 14")
 SC2026 (14" x 20")

CAUTION
DOOR SWINGS
INWARD

SA2027 (7" x 10")
 SS2027 (10" x 14")
 SC2027 (14" x 20")

CAUTION
USE
HANDRAIL

SA2028 (7" x 10")
 SS2028 (10" x 14")
 SC2028 (14" x 20")

CAUTION
KEEP THIS
DOOR CLOSED

SA2029 (7" x 10")
 SS2029 (10" x 14")
 SC2029 (14" x 20")

CAUTION
FIRE DOOR
DO NOT BLOCK

SA2030 (7" x 10")
 SS2030 (10" x 14")
 SC2030 (14" x 20")

CAUTION
LOW
HEADROOM

SA2031 (7" x 10")
 SS2031 (10" x 14")
 SC2031 (14" x 20")

CAUTION
THIS MACHINE
STARTS BY
REMOTE CONTROL

SA2032 (7" x 10")
 SS2032 (10" x 14")
 SC2032 (14" x 20")

CAUTION
IMPAIRED
HEADROOM

SA2033 (7" x 10")
 SS2033 (10" x 14")
 SC2033 (14" x 20")

CAUTION
EQUIPMENT
OPERATED BY
REMOTE CONTROL

SA2034 (7" x 10")
 SS2034 (10" x 14")
 SC2034 (14" x 20")

CAUTION
HIGH PRESSURE
PIPELINE

SA2035 (7" x 10")
 SS2035 (10" x 14")
 SC2035 (14" x 20")

CAUTION
LOW OVERHEAD
CLEARANCE

SA2036 (7" x 10")
 SS2036 (10" x 14")
 SC2036 (14" x 20")

CAUTION
OVERHEAD
WORK

SA2037 (7" x 10")
 SS2037 (10" x 14")
 SC2037 (14" x 20")

CAUTION
STATIC CONTROL
AREA

SA2038 (7" x 10")
 SS2038 (10" x 14")
 SC2038 (14" x 20")

CAUTION
PREVENT STATIC
SPARK DISCHARGE
USE GROUNDING DEVICES

SA2039 (7" x 10")
 SS2039 (10" x 14")
 SC2039 (14" x 20")

CAUTION
ATTACH
GROUNDING
CABLES

SA2040 (7" x 10")
 SS2040 (10" x 14")
 SC2040 (14" x 20")

CAUTION
USE STATIC
GROUNDING
DEVICES

SA2041 (7" x 10")
 SS2041 (10" x 14")
 SC2041 (14" x 20")

CAUTION
GROUND
ALL BARRELS

SA2042 (7" x 10")
 SS2042 (10" x 14")
 SC2042 (14" x 20")

CAUTION
CLEARANCE

FT _____
IN

SA2043 (7" x 10")
 SS2043 (10" x 14")
 SC2043 (14" x 20")

CAUTION
ATMOSPHERE
MAY BE HAZARDOUS
FOLLOW CONFINED SPACE
ENTRY PROCEDURES

SA2044 (7" x 10")
 SS2044 (10" x 14")
 SC2044 (14" x 20")

CAUTION
CONTAINS
HAZARDOUS
MATERIAL

SA2045 (7" x 10")
 SS2045 (10" x 14")
 SC2045 (14" x 20")

CAUTION
SECURE ALL
TANKS
CHAIN
CYLINDERS

SA2046 (7" x 10")
 SS2046 (10" x 14")
 SC2046 (14" x 20")

CAUTION
BURIED
CABLE

SA2047 (7" x 10")
 SS2047 (10" x 14")
 SC2047 (14" x 20")

CAUTION
UNDERGROUND
CABLE

SA2048 (7" x 10")
 SS2048 (10" x 14")
 SC2048 (14" x 20")

CAUTION
VOLTS 

SA2049 (7" x 10")
 SS2049 (10" x 14")
 SC2049 (14" x 20")

CAUTION
ELECTRICAL
EQUIPMENT
AUTHORIZED
PERSONNEL ONLY 

SA2050 (7" x 10")
 SS2050 (10" x 14")
 SC2050 (14" x 20")

CAUTION
HIGH
VOLTAGE
KEEP OUT 

SA2051 (7" x 10")
 SS2051 (10" x 14")
 SC2051 (14" x 20")

CAUTION
HIGH
VOLTAGE 

SA2052 (7" x 10")
 SS2052 (10" x 14")
 SC2052 (14" x 20")

CAUTION
HIGH
VOLTAGE
OVERHEAD 

SA2053 (7" x 10")
 SS2053 (10" x 14")
 SC2053 (14" x 20")

CAUTION
EQUIPMENT
MAY START
AUTOMATICALLY

SA2054 (7" x 10")
 SS2054 (10" x 14")
 SC2054 (14" x 20")

CAUTION
PERSONAL PROTECTIVE
EQUIPMENT REQUIRED
IN THIS AREA

SA2055 (7" x 10")
SS2055 (10" x 14")
SC2055 (14" x 20")

CAUTION
DUE TO

SA2056 (7" x 10")
SS2056 (10" x 14")
SC2056 (14" x 20")

CAUTION
EQUIPMENT STARTS
AUTOMATICALLY

SA2057 (7" x 10")
SS2057 (10" x 14")
SC2057 (14" x 20")

CAUTION
CHILDREN
PLAYING 

SA2058 (7" x 10")
SS2058 (10" x 14")
SC2058 (14" x 20")

CAUTION
THIS EQUIPMENT
STARTS AND STOP
AUTOMATICALLY

SA2059 (7" x 10")
SS2059 (10" x 14")
SC2059 (14" x 20")

CAUTION
EAR PROTECTION
REQUIRED
IN THIS AREA

SA2060 (7" x 10")
SS2060 (10" x 14")
SC2060 (14" x 20")

CAUTION
DOUBLE HEARING
PROTECTION REQUIRED
IN THIS AREA

SA2061 (7" x 10")
SS2061 (10" x 14")
SC2061 (14" x 20")

CAUTION
VENTING

SA2062 (7" x 10")
SS2062 (10" x 14")
SC2062 (14" x 20")

CAUTION
WORKING
ABOVE 

SA2063 (7" x 10")
SS2063 (10" x 14")
SC2063 (14" x 20")

CAUTION
PPE
REQUIRED

SA2064 (7" x 10")
SS2064 (10" x 14")
SC2064 (14" x 20")

CAUTION
EAR AND EYE
PROTECTION MUST BE
WORN IN THIS AREA

SA2065 (7" x 10")
SS2065 (10" x 14")
SC2065 (14" x 20")

CAUTION
PERSONAL PROTECTIVE
EQUIPMENT REQUIRED
PAST THIS POINT

SA2066 (7" x 10")
SS2066 (10" x 14")
SC2066 (14" x 20")

CAUTION
PPE REQUIRED IN THIS AREA

SA2067 (7" x 10")
SS2067 (10" x 14")
SC2067 (14" x 20")

CAUTION
KEEP CLEAR

SA2068 (7" x 10")
SS2068 (10" x 14")
SC2068 (14" x 20")

CAUTION
WATCH
YOUR HEAD

SA2069 (7" x 10")
SS2069 (10" x 14")
SC2069 (14" x 20")

CAUTION
EYE
PROTECTION
REQUIRED 

SA2070 (7" x 10")
SS2070 (10" x 14")
SC2070 (14" x 20")

CAUTION
FALLING
HAZARD

SA2071 (7" x 10")
SS2071 (10" x 14")
SC2071 (14" x 20")

CAUTION
HOT

SA2072 (7" x 10")
SS2072 (10" x 14")
SC2072 (14" x 20")

CAUTION
WATCH FOR FALLING
ICE AND SNOW

SA2073 (7" x 10")
SS2073 (10" x 14")
SC2073 (14" x 20")

CAUTION
HEARING
PROTECTION
REQUIRED 

SA2074 (7" x 10")
SS2074 (10" x 14")
SC2074 (14" x 20")

CAUTION
SAFETY GLASSES
MUST BE WORN
AT ALL TIMES 

SA2075 (7" x 10")
SS2075 (10" x 14")
SC2075 (14" x 20")

CAUTION
SOUND HORN
PROCEED SLOWLY

SA2076 (7" x 10")
SS2076 (10" x 14")
SC2076 (14" x 20")

CAUTION
HAZARDOUS
WASTE

SA2077 (7" x 10")
SS2077 (10" x 14")
SC2077 (14" x 20")

CAUTION
EAR, EYE AND
FOOT PROTECTION
REQUIRED IN THIS AREA

SA2078 (7" x 10")
SS2078 (10" x 14")
SC20738 (14" x 20")

CAUTION
HARD HAT AND
SAFETY GLASSES
REQUIRED
BEYOND THIS POINT

SA2079 (7" x 10")
SS2079 (10" x 14")
SC2079 (14" x 20")

CAUTION
HEARING
PROTECTION
REQUIRED BEYOND
THIS POINT 

SA2080 (7" x 10")
SS2080 (10" x 14")
SC2080 (14" x 20")

CAUTION
CHEMICAL GOGGLES
REQUIRED BEYOND
THIS POINT 

SA2081 (7" x 10")
SS2081 (10" x 14")
SC2081 (14" x 20")

CAUTION
WATCH
FOR LIFT
TRUCKS 

NOTICE Safety Signs

It is the sole responsibility of the user to determine the suitability of this product for their application, including, but not limited to, identifying the risk and its classification. When in doubt consult a qualified professional.

Choose from our variety of materials for the best fit for your particular application. Don't see the legend you need? Give us a call to see what we can do for your next sign requirement.

HOW TO ORDER:

SELECT SIGN - **SS4000** SELECT SIGN TYPE - **V** ADD TOGETHER. - **SS4000V**

SIGN ARMOR			
Weather, Chemical, Abrasion & Graffiti Resistant Coating			
V	P	A	MV
Adhesive VynMark	Semi-Rigid Plastic	Aluminum	Magnetic Sheeting

OVER-LAMINATION FILM		
High Performance Outdoor UV Film		
VL	PL	AL
Adhesive VynMark	Semi Rigid Plastic	Aluminum

NOTICE
EMPLOYEES ONLY 

SA4000 (7" x 10")
SS4000 (10" x 14")
SC4000 (14" x 20")

NOTICE
NON POTABLE WATER
NOT TO BE USED FOR
DRINKING, WASHING
OR COOKING PURPOSES

SA4001 (7" x 10")
SS4001 (10" x 14")
SC4001 (14" x 20")

NOTICE
NO SMOKING 

SA4002 (7" x 10")
SS4002 (10" x 14")
SC4002 (14" x 20")

NOTICE
DESIGNATED
SMOKING
AREA 

SA4003 (7" x 10")
SS4003 (10" x 14")
SC4003 (14" x 20")

NOTICE
CLEARANCE
_____ FT

SA4004 (7" x 10")
SS4004 (10" x 14")
SC4004 (14" x 20")

NOTICE
USED OIL

SA4005 (7" x 10")
SS4005 (10" x 14")
SC4005 (14" x 20")

NOTICE
KEEP THIS
AREA CLEAR

SA4006 (7" x 10")
SS4006 (10" x 14")
SC4006 (14" x 20")

NOTICE
ANY ACCIDENTS MUST
BE REPORTED TO SUPERVISOR
BEFORE LEAVING SHIFT

SA4007 (7" x 10")
SS4007 (10" x 14")
SC4007 (14" x 20")

NOTICE
ALL VEHICLES AND
PERSONNEL ENTERING OR
LEAVING THE PREMISES
SUBJECT TO SEARCH

SA4008 (7" x 10")
SS4008 (10" x 14")
SC4008 (14" x 20")

NOTICE
NO FOOD OR DRINK
BEYOND THIS POINT

SA4009 (7" x 10")
SS4009 (10" x 14")
SC4009 (14" x 20")

NOTICE
SOUND
BEFORE
ENTERING 

SA4010 (7" x 10")
SS4010 (10" x 14")
SC4010 (14" x 20")

NOTICE
PLEASE
RING BELL

SA4011 (7" x 10")
SS4011 (10" x 14")
SC4011 (14" x 20")

NOTICE
EMPTY
CYLINDERS 

SA4012 (7" x 10")
SS4012 (10" x 14")
SC4012 (14" x 20")

NOTICE
FULL
CYLINDERS 

SA4013 (7" x 10")
SS4013 (10" x 14")
SC4013 (14" x 20")

NOTICE
CHAIN
ALL CYLINDERS
SECURELY 

SA4014 (7" x 10")
SS4014 (10" x 14")
SC4014 (14" x 20")

NOTICE
SECURITY ALARM
WILL SOUND IF
DOOR IS OPENED

SA4015 (7" x 10")
SS4015 (10" x 14")
SC4015 (14" x 20")

NOTICE
DOOR ALARMED
OPEN ONLY FOR
EMERGENCY EXIT

SA4016 (7" x 10")
SS4016 (10" x 14")
SC4016 (14" x 20")

NOTICE
CARS PARKED
IN THIS LOT
AT OWNER'S RISK

SA4017 (7" x 10")
SS4017 (10" x 14")
SC4017 (14" x 20")

NOTICE
NO
PARKING 

SA4018 (7" x 10")
SS4018 (10" x 14")
SC4018 (14" x 20")

NOTICE
VISITORS
PARKING
ONLY 

SA4019 (7" x 10")
SS4019 (10" x 14")
SC4019 (14" x 20")

NOTICE
NO TRUCK
DRIVERS BEYOND
THIS POINT

SA4020 (7" x 10")
SS4020 (10" x 14")
SC4020 (14" x 20")

NOTICE
TRUCK DRIVERS
MUST REMAIN
WITH THEIR VEHICLE

SA4021 (7" x 10")
SS4021 (10" x 14")
SC4021 (14" x 20")

NOTICE
TRUCK DRIVERS
SHUT OFF MOTOR,
SET BRAKES, SET WHEEL CHOCKS

SA4022 (7" x 10")
SS4022 (10" x 14")
SC4022 (14" x 20")

NOTICE
PLEASE DEPOSIT
ALL RUBBISH IN
RECEPTACLES
PROVIDED 

SA4023 (7" x 10")
SS4023 (10" x 14")
SC4023 (14" x 20")

NOTICE
KEEP THIS
AREA CLEAN

SA4024 (7" x 10")
SS4024 (10" x 14")
SC4024 (14" x 20")

NOTICE
PERSONAL PROTECTION
REQUIRED IN
THIS AREA

SA4025 (7" x 10")
SS4025 (10" x 14")
SC4025 (14" x 20")

NOTICE
SAFETY FOOTWEAR
REQUIRED IN
THIS AREA 

SA4026 (7" x 10")
SS4026 (10" x 14")
SC4026 (14" x 20")

NOTICE
TURN OFF
THE LIGHTS

SA4027 (7" x 10")
SS4027 (10" x 14")
SC4027 (14" x 20")

NOTICE
MUSTER
POINT 

SA4028 (7" x 10")
SS4028 (10" x 14")
SC4028 (14" x 20")

NOTICE
THIS PROPERTY IS UNDER
VIDEO SURVEILLANCE

SA4029 (7" x 10")
SS4029 (10" x 14")
SC4029 (14" x 20")

NOTICE
NO CELLULAR
PHONES
ALLOWED 

SA4030 (7" x 10")
SS4030 (10" x 14")
SC4030 (14" x 20")

NOTICE
DUE TO

SA4031 (7" x 10")
SS4031 (10" x 14")
SC4031 (14" x 20")

NOTICE
DOOR FOR
EMERGENCY
USE ONLY

SA4032 (7" x 10")
SS4032 (10" x 14")
SC4032 (14" x 20")

NOTICE
NO
FOOD OR DRINK
IN THIS AREA

SA4033 (7" x 10")
SS4033 (10" x 14")
SC4033 (14" x 20")

NOTICE
ALL PPE
MUST BE WORN

SA4034 (7" x 10")
SS4034 (10" x 14")
SC4034 (14" x 20")

NOTICE
CHOCK WHEELS
WHILE LOADING
OR UNLOADING

SA4035 (7" x 10")
SS4035 (10" x 14")
SC4035 (14" x 20")

NOTICE
SCBA
EQUIPMENT INSIDE

SA4036 (7" x 10")
SS4036 (10" x 14")
SC4036 (14" x 20")

NOTICE
RESTRICTED AREA
AUTHORIZED
PERSONNEL ONLY

SA4037 (7" x 10")
SS4037 (10" x 14")
SC4037 (14" x 20")

NOTICE
NO ADMITTANCE
APPLY AT OFFICE

SA4038 (7" x 10")
SS4038 (10" x 14")
SC4038 (14" x 20")

NOTICE
NO ENTRY
UNLESS AUTHORIZED

SA4039 (7" x 10")
SS4039 (10" x 14")
SC4039 (14" x 20")

NOTICE
EMPLOYEE
ENTRANCE ONLY

SA4040 (7" x 10")
SS4040 (10" x 14")
SC4040 (14" x 20")

NOTICE
NO
TRESPASSING

SA4041 (7" x 10")
SS4041 (10" x 14")
SC4041 (14" x 20")

NOTICE
PRIVATE PROPERTY
KEEP OUT

SA4042 (7" x 10")
SS4042 (10" x 14")
SC4042 (14" x 20")

NOTICE
NO ALCOHOL OR DRUGS
PERMITTED ON
COMPANY PREMISES

SA4043 (7" x 10")
SS4043 (10" x 14")
SC4043 (14" x 20")

NOTICE
DO NOT BLOCK
DOOR

SA4044 (7" x 10")
SS4044 (10" x 14")
SC4044 (14" x 20")

NOTICE
KEEP DOOR
CLOSED

SA4045 (7" x 10")
SS4045 (10" x 14")
SC4045 (14" x 20")

NOTICE
OUT OF
SERVICE

SA4046 (7" x 10")
SS4046 (10" x 14")
SC4046 (14" x 20")

NOTICE
NO ADMITTANCE
EMPLOYEES ONLY

SA4047 (7" x 10")
SS4047 (10" x 14")
SC4047 (14" x 20")

NOTICE
ELECTRICAL ROOM
NO STORAGE
PERMITTED

SA4048 (7" x 10")
SS4048 (10" x 14")
SC4048 (14" x 20")

NOTICE
ALL VISITORS MUST
REPORT TO OFFICE

SA4049 (7" x 10")
SS4049 (10" x 14")
SC4049 (14" x 20")

NOTICE
SAFETY GLASSES
REQUIRED BEYOND
THIS POINT 

SA4050 (7" x 10")
SS4050 (10" x 14")
SC4050 (14" x 20")

NOTICE
PERSONAL PROTECTIVE
EQUIPMENT REQUIRED
IN THIS AREA

SA4051 (7" x 10")
SS4051 (10" x 14")
SC4051 (14" x 20")

NOTICE
CLEANING
SUPPLIES

SA4052 (7" x 10")
SS4052 (10" x 14")
SC4052 (14" x 20")

NOTICE
PROTECTIVE
EQUIPMENT
STORAGE

SA4053 (7" x 10")
SS4053 (10" x 14")
SC4053 (14" x 20")

NOTICE
THIS IS A
SMOKE FREE
FACILITY

SA4054 (7" x 10")
SS4054 (10" x 14")
SC4054 (14" x 20")

NOTICE
PHOTO ID
REQUIRED

SA4055 (7" x 10")
SS4055 (10" x 14")
SC4055 (14" x 20")

NOTICE
HARD HAT, SAFETY VEST
AND BOOTS REQUIRED
BEYOND THIS POINT

SA4056 (7" x 10")
SS4056 (10" x 14")
SC4056 (14" x 20")

NOTICE
HARD HAT, SAFETY GLASSES
AND BOOTS REQUIRED
BEYOND THIS POINT

SA4057 (7" x 10")
SS4057 (10" x 14")
SC4057 (14" x 20")

NOTICE
AUTHORIZED
PERSONNEL ONLY

SA4058 (7" x 10")
SS4058 (10" x 14")
SC4058 (14" x 20")

NOTICE
BACK IN
ONLY

SA4059 (7" x 10")
SS4059 (10" x 14")
SC4059 (14" x 20")

NOTICE
STORAGE
AREA

SA4060 (7" x 10")
SS4060 (10" x 14")
SC4060 (14" x 20")

NOTICE
THIS AREA IS UNDER 24 HOUR
VIDEO SURVEILLANCE



SA4061 (7" x 10")
SS4061 (10" x 14")
SC4061 (14" x 20")

NOTICE
WATCH
YOUR STEP

SA4062 (7" x 10")
SS4062 (10" x 14")
SC4062 (14" x 20")

NOTICE
PPE REQUIRED
HARD HAT, COVERALLS, EYE PROTECTION
& SAFETY BOOTS



SA4063 (7" x 10")
SS4063 (10" x 14")
SC4063 (14" x 20")

NOTICE
NO
ADMITTANCE

SA4064 (7" x 10")
SS4064 (10" x 14")
SC4064 (14" x 20")

NOTICE
NO
SOLICITING

SA4065 (7" x 10")
SS4065 (10" x 14")
SC4065 (14" x 20")

NOTICE
NO
DUMPING

SA4066 (7" x 10")
SS4066 (10" x 14")
SC40366 (14" x 20")

NOTICE
WASH HANDS
BEFORE RETURNING
TO WORK

SA4067 (7" x 10")
SS4067 (10" x 14")
SC4067 (14" x 20")

NOTICE
SHIPPING AND
RECEIVING

SA4068 (7" x 10")
SS4068 (10" x 14")
SC4068 (14" x 20")

NOTICE
SAFETY GLASSES
HEARING PROTECTION
SAFETY SHOES
REQUIRED BEYOND THIS POINT

SA4069 (7" x 10")
SS4069 (10" x 14")
SC4069 (14" x 20")

NOTICE
SAFETY GLASSES AND
HEARING PROTECTION
REQUIRED

SA4070 (7" x 10")
SS4070 (10" x 14")
SC4070 (14" x 20")

NOTICE
SAFETY GLASSES
HEARING PROTECTION
AND SAFETY FOOTWEAR
REQUIRED

SA4071 (7" x 10")
SS4071 (10" x 14")
SC4071 (14" x 20")

NOTICE
SAFETY GLASSES
AND SAFETY FOOTWEAR
REQUIRED BEYOND THIS POINT

SA4072 (7" x 10")
SS4072 (10" x 14")
SC4072 (14" x 20")

NOTICE
NO SMOKING, EATING OR
DRINKING IN THIS AREA

SA4073 (7" x 10")
SS4073 (10" x 14")
SC4073 (14" x 20")

NOTICE
 **TORNADO**
SHELTER

SA4074 (7" x 10")
SS4074 (10" x 14")
SC4074 (14" x 20")



CUSTOM SIGNS

Custom Sign Options
Call for details

Unable to find the sign you need to communicate your message in our wide variety of off-the-shelf signs? Give us a call to see what we can do for your next sign requirement.

SAFETY & HOUSE KEEPING Signs

Must be used where there is a need for general instructions and suggestions relative to safety measures. OSHA specifies that safety instruction signs must have a white background, green panel and white letters. Any letters used on the white background must be black.

It is the sole responsibility of the user to determine the suitability of this product for their application, including, but not limited to, identifying the risk and its classification. When in doubt consult a qualified professional.

Choose from our variety of materials for the best fit for your particular application. Don't see the legend you need? Give us a call to see what we can do for your next sign requirement.

HOW TO ORDER:

SELECT SIGN - **SS5000** SELECT SIGN TYPE - **V** ADD TOGETHER - **SS5000V**

SIGN ARMOR <i>Weather, Chemical, Abrasion & Graffiti Resistant Coating</i>			
V	P	A	MV
Adhesive VynMark	Semi-Rigid Plastic	Aluminum	Magnetic Sheeting

OVER-LAMINATION FILM <i>High Performance Outdoor UV Film</i>		
VL	PL	AL
Adhesive VynMark	Semi Rigid Plastic	Aluminum

<p>SAFETY FIRST</p> <p>FIRST AID ROOM </p> <p>SA5000 (7" x 10") SS5000 (10" x 14") SC5000 (14" x 20")</p>	<p>SAFETY FIRST</p> <p>FIRST AID KIT </p> <p>SA5001 (7" x 10") SS5001 (10" x 14") SC5001 (14" x 20")</p>	<p>SAFETY FIRST</p> <p>STRETCHER HERE </p> <p>SA5002 (7" x 10") SS5002 (10" x 14") SC5002 (14" x 20")</p>	<p>SAFETY FIRST</p> <p>EMERGENCY SHOWER </p> <p>SA5003 (7" x 10") SS5003 (10" x 14") SC5003 (14" x 20")</p>	<p>SAFETY FIRST</p> <p>EMERGENCY EYE WASH STATION </p> <p>SA5004 (7" x 10") SS5004 (10" x 14") SC5004 (14" x 20")</p>
<p>SAFETY FIRST</p> <p>EMERGENCY SHOWER AND EYE WASH </p> <p>SA5005 (7" x 10") SS5005 (10" x 14") SC5005 (14" x 20")</p>	<p>SAFETY FIRST</p> <p>EYE PROTECTION AREA </p> <p>SA5006 (7" x 10") SS5006 (10" x 14") SC5006 (14" x 20")</p>	<p>SAFETY FIRST</p> <p>WEAR GOGGLES ON THIS OPERATION </p> <p>SA5007 (7" x 10") SS5007 (10" x 14") SC5007 (14" x 20")</p>	<p>SAFETY FIRST</p> <p>EAR PROTECTION AREA </p> <p>SA5008 (7" x 10") SS5008 (10" x 14") SC5008 (14" x 20")</p>	<p>SAFETY FIRST</p> <p>HEARING PROTECTION MUST BE WORN IN THIS AREA </p> <p>SA5009 (7" x 10") SS5009 (10" x 14") SC5009 (14" x 20")</p>
<p>SAFETY FIRST</p> <p>HARD HAT AREA </p> <p>SA5010 (7" x 10") SS5010 (10" x 14") SC5010 (14" x 20")</p>	<p>SAFETY FIRST</p> <p>HARD HATS ARE REQUIRED IN THIS AREA </p> <p>SA5011 (7" x 10") SS5011 (10" x 14") SC5011 (14" x 20")</p>	<p>SAFETY FIRST</p> <p>GLOVES REQUIRED IN THIS AREA </p> <p>SA5012 (7" x 10") SS5012 (10" x 14") SC5012 (14" x 20")</p>	<p>SAFETY FIRST</p> <p>SAFETY FOOTWEAR REQUIRED IN THIS AREA </p> <p>SA5013 (7" x 10") SS5013 (10" x 14") SC5013 (14" x 20")</p>	<p>SAFETY FIRST</p> <p>FACE SHIELDS REQUIRED IN THIS AREA </p> <p>SA5014 (7" x 10") SS5014 (10" x 14") SC5014 (14" x 20")</p>
<p>SAFETY FIRST</p> <p>RESPIRATORS REQUIRED IN THIS AREA </p> <p>SA5015 (7" x 10") SS5015 (10" x 14") SC5015 (14" x 20")</p>	<p>SAFETY FIRST</p> <p>WEAR PROTECTIVE CLOTHING IN THIS AREA </p> <p>SA5016 (7" x 10") SS5016 (10" x 14") SC5016 (14" x 20")</p>	<p>SAFETY FIRST</p> <p>WEAR FACE SHIELD AND RUBBER GLOVES WHEN HANDLING CHEMICALS</p> <p>SA5017 (7" x 10") SS5017 (10" x 14") SC5017 (14" x 20")</p>	<p>SAFETY FIRST</p> <p>REPORT ALL INJURIES AT ONCE </p> <p>SA5018 (7" x 10") SS5018 (10" x 14") SC5018 (14" x 20")</p>	<p>SAFETY FIRST</p> <p>CARELESSNESS MAY COST A LIFE</p> <p>SA5019 (7" x 10") SS5019 (10" x 14") SC5019 (14" x 20")</p>
<p>SAFETY FIRST</p> <p>A FIRE TODAY NO JOB TOMORROW</p> <p>SA5020 (7" x 10") SS5020 (10" x 14") SC5020 (14" x 20")</p>	<p>SAFETY FIRST</p> <p>A CAREFUL WORKER IS THE BEST SAFETY DEVICE</p> <p>SA5021 (7" x 10") SS5021 (10" x 14") SC5021 (14" x 20")</p>	<p>SAFETY FIRST</p> <p>OTHERS ARE DEPENDING ON YOU DON'T TAKE CHANCES</p> <p>SA5022 (7" x 10") SS5022 (10" x 14") SC5022 (14" x 20")</p>	<p>SAFETY FIRST</p> <p>THE SAFE WAY IS THE BEST WAY</p> <p>SA5023 (7" x 10") SS5023 (10" x 14") SC5023 (14" x 20")</p>	<p>SAFETY FIRST</p> <p>THIS GATE MUST BE KEPT CLOSED</p> <p>SA5024 (7" x 10") SS5024 (10" x 14") SC5024 (14" x 20")</p>

SAFETY
FIRST
**LOCK OUT ALL
POWER SOURCES**

SA5025 (7" x 10")
SS5025 (10" x 14")
SC5025 (14" x 20")

SAFETY
FIRST
**DO NOT OIL OR
CLEAN MACHINERY
WHILE IN MOTION**

SA5026 (7" x 10")
SS5026 (10" x 14")
SC5026 (14" x 20")

SAFETY
FIRST
**DO NOT PUT ON OR
TAKE OFF BELTS
WHILE MACHINERY
IS IN MOTION**

SA5027 (7" x 10")
SS5027 (10" x 14")
SC5027 (14" x 20")

SAFETY
FIRST
**HELP KEEP
THIS PLANT
SAFE AND CLEAN**

SA5028 (7" x 10")
SS5028 (10" x 14")
SC5028 (14" x 20")

SAFETY
FIRST
**KEEP THIS
AREA CLEAR**

SA5029 (7" x 10")
SS5029 (10" x 14")
SC5029 (14" x 20")

SAFETY
FIRST
**PUT TOOLS
BACK IN THEIR
PROPER PLACE**

SA5030 (7" x 10")
SS5030 (10" x 14")
SC5030 (14" x 20")

SAFETY
FIRST
**CLIMB LADDERS
SLOWLY AND USE
BOTH HANDS**

SA5031 (7" x 10")
SS5031 (10" x 14")
SC5031 (14" x 20")

SAFETY
FIRST
**STAY ALERT
DON'T GET HURT**

SA5032 (7" x 10")
SS5032 (10" x 14")
SC5032 (14" x 20")

SAFETY
FIRST

NO ACCIDENTS

SA5033 (7" x 10")
SS5033 (10" x 14")
SC5033 (14" x 20")

SAFETY
FIRST
**BE
CAREFUL**

SA5034 (7" x 10")
SS5034 (10" x 14")
SC5034 (14" x 20")

THINK
**CONSERVE
WATER**

SA5035 (7" x 10")
SS5035 (10" x 14")
SC5035 (14" x 20")

THINK
**CONSERVE
ENERGY**

SA5036 (7" x 10")
SS5036 (10" x 14")
SC5036 (14" x 20")

THINK
SAFETY

SA5037 (7" x 10")
SS5037 (10" x 14")
SC5037 (14" x 20")

THINK
**BEFORE
YOU ACT**

SA5038 (7" x 10")
SS5038 (10" x 14")
SC5038 (14" x 20")

THINK
**SAFETY IS
EVERYONE'S
BUSINESS**

SA5039 (7" x 10")
SS5039 (10" x 14")
SC5039 (14" x 20")

**ALUMINUM
CANS ONLY**

SA5040 (7" x 10")
SS5040 (10" x 14")
SC5040 (14" x 20")

**CARDBOARD
ONLY**

SA5041 (7" x 10")
SS5041 (10" x 14")
SC5041 (14" x 20")

**PAPER
ONLY**

SA5042 (7" x 10")
SS5042 (10" x 14")
SC5042 (14" x 20")

**PLASTIC
ONLY**

SA5043 (7" x 10")
SS5043 (10" x 14")
SC5043 (14" x 20")

**GLASS
ONLY**

SA5044 (7" x 10")
SS5044 (10" x 14")
SC5044 (14" x 20")



SA5045 (7" x 10")
SS5045 (10" x 14")
SC5045 (14" x 20")

EMERGENCY
**SPILL RESPONSE
EQUIPMENT**

SA5046 (7" x 10")
SS5046 (10" x 14")
SC5046 (14" x 20")

SAFETY
FIRST
**FIRST AID
STATION**

SA5047 (7" x 10")
SS5047 (10" x 14")
SC5047 (14" x 20")

SAFETY
FIRST
**KEEP THIS AREA
CLEAN AND
ORDERLY**

SA5048 (7" x 10")
SS5048 (10" x 14")
SC5048 (14" x 20")

SAFETY
FIRST
**IN CASE OF
EMERGENCY
DIAL 911**

SA5049 (7" x 10")
SS5049 (10" x 14")
SC5049 (14" x 20")

**FIRST AID KIT
INSIDE**

SA5050 (7" x 10")
SS5050 (10" x 14")
SC5050 (14" x 20")



SAFETY
FIRST
**EMERGENCY
EYE WASH
STATION** 

Bilingual Safety Signs English/Spanish







Use these safety signs as a great way to communicate health and safety issues in a bilingual working environment. We offer a variety of different material types to meet all budgets and durability issues. We can also make any custom signs you require.

HOW TO ORDER:

SELECT SIGN - **SS6500** SELECT SIGN TYPE - **V** ADD TOGETHER. - **SS6500V**

SIGN ARMOR <i>Weather, Chemical, Abrasion & Graffiti Resistant Coating</i>				OVER-LAMINATION FILM <i>High Performance Outdoor UV Film</i>		
V	P	A	MV	VL	PL	AL
Adhesive VynMark	Semi-Rigid Plastic	Aluminum	Magnetic Sheeting	Adhesive VynMark	Semi Rigid Plastic	Aluminum

 <p>SS6500 (10" x 14")</p>	 <p>SS6501 (10" x 14")</p>	 <p>SS6502 (10" x 14")</p>	 <p>SS6503 (10" x 14")</p>	 <p>SS6504 (10" x 14")</p>	 <p>SS6505 (10" x 14")</p>	 <p>SS6506 (10" x 14")</p>
---	---	---	---	--	---	---

 <p>SS6514 (10" x 14")</p>	 <p>SS6515 (10" x 14")</p>	 <p>SS6516 (10" x 14")</p>	 <p>SS6517 (10" x 14")</p>	 <p>SS6518 (10" x 14")</p>	 <p>SS6519 (10" x 14")</p>	 <p>SS6520 (10" x 14")</p>
--	--	--	--	---	--	--

 <p>SS6507 (10" x 14")</p>	 <p>SS6508 (10" x 14")</p>	 <p>SS6509 (10" x 14")</p>	 <p>SS6510 (10" x 14")</p>	 <p>SS6511 (10" x 14")</p>	 <p>SS6512 (10" x 14")</p>	 <p>SS6513 (10" x 14")</p>
---	---	---	---	--	---	---

 <p>SS6521 (10" x 14")</p>	 <p>SS6522 (10" x 14")</p>	 <p>SS6523 (10" x 14")</p>	 <p>SS6524 (10" x 14")</p>	 <p>SS6525 (10" x 14")</p>	 <p>SS6526 (10" x 14")</p>	 <p>SS6527 (10" x 14")</p>
---	---	---	---	--	---	---

 <p>SS6528 (10" x 14")</p>	 <p>SS6529 (10" x 14")</p>	 <p>SS6530 (10" x 14")</p>	 <p>SS6531 (10" x 14")</p>	 <p>SS6532 (10" x 14")</p>	 <p>SS6533 (10" x 14")</p>	 <p>SS6534 (10" x 14")</p>
---	---	---	---	--	---	---

Workplace Safety Signs Spanish

Use these safety signs as a great way to communicate health and safety issues in a Spanish language working environment. We offer a variety of different material types to meet all budgets and durability issues. We can also make any custom signs you require.



SAS1005 (7" x 10")
SSS1005 (10" x 14")
SCS1005 (14" x 20")



SAS1111 (7" x 10")
SSS1111 (10" x 14")
SCS1111 (14" x 20")



SAS1026 (7" x 10")
SSS1026 (10" x 14")
SCS1026 (14" x 20")



SAS1002 (7" x 10")
SSS1002 (10" x 14")
SCS1002 (14" x 20")



SAS1114 (7" x 10")
SSS1114 (10" x 14")
SCS1114 (14" x 20")



SAS1010 (7" x 10")
SSS1010 (10" x 14")
SCS1010 (14" x 20")



SAS1075 (7" x 10")
SSS1075 (10" x 14")
SCS1075 (14" x 20")



SAS1133 (7" x 10")
SSS1133 (10" x 14")
SCS1133 (14" x 20")



SAS1084 (7" x 10")
SSS1084 (10" x 14")
SCS1084 (14" x 20")



SAS1085 (7" x 10")
SSS1085 (10" x 14")
SCS1085 (14" x 20")



SAS1032 (7" x 10")
SSS1032 (10" x 14")
SCS1032 (14" x 20")



SAS1068 (7" x 10")
SSS1068 (10" x 14")
SCS1068 (14" x 20")



SAS1025 (7" x 10")
SSS1025 (10" x 14")
SCS1025 (14" x 20")



SAS1029 (7" x 10")
SSS1029 (10" x 14")
SCS1029 (14" x 20")



SAS1070 (7" x 10")
SSS1070 (10" x 14")
SCS1070 (14" x 20")



SAS2004 (7" x 10")
SSS2004 (10" x 14")
SCS2004 (14" x 20")



SAS2018 (7" x 10")
SSS2018 (10" x 14")
SCS2018 (14" x 20")



SAS2074 (7" x 10")
SSS2074 (10" x 14")
SCS2074 (14" x 20")



SAS2070 (7" x 10")
SSS2070 (10" x 14")
SCS2070 (14" x 20")



SAS2084 (7" x 10")
SSS2084 (10" x 14")
SCS2084 (14" x 20")



SAS4058 (7" x 10")
SSS4058 (10" x 14")
SCS4058 (14" x 20")



SAS4029 (7" x 10")
SSS4029 (10" x 14")
SCS4029 (14" x 20")



SAS4061 (7" x 10")
SSS4061 (10" x 14")
SCS4061 (14" x 20")



SAS4033 (7" x 10")
SSS4033 (10" x 14")
SCS4033 (14" x 20")



SAS4006 (7" x 10")
SSS4006 (10" x 14")
SCS4006 (14" x 20")



SAS5004 (7" x 10")
SSS5004 (10" x 14")
SCS5004 (14" x 20")



SAS5003 (7" x 10")
SSS5003 (10" x 14")
SCS5003 (14" x 20")



SAS5000 (7" x 10")
SSS5000 (10" x 14")
SCS5000 (14" x 20")



SAS5001 (7" x 10")
SSS5001 (10" x 14")
SCS5001 (14" x 20")



SAS5018 (7" x 10")
SSS5018 (10" x 14")
SCS5018 (14" x 20")







Bilingual Safety Signs English/French







Use these safety signs as a great way to communicate health and safety issues in a bilingual working environment. We offer a variety of different material types to meet all budgets and durability issues. We can also make any custom signs you require.







HOW TO ORDER:







SELECT SIGN - **SS6000** SELECT SIGN TYPE - **V** ADD TOGETHER. - **SS6000V**







SIGN ARMOR				OVER-LAMINATION FILM		
Weather, Chemical, Abrasion & Graffiti Resistant Coating				High Performance Outdoor UV Film		
V	P	A	MV	VL	PL	AL
Adhesive VynMark	Semi-Rigid Plastic	Aluminum	Magnetic Sheeting	Adhesive VynMark	Semi Rigid Plastic	Aluminum

 <p>DANGER AUTHORIZED PERSONNEL ONLY</p> <p>DANGER PERSONNEL AUTORISÉ SEULEMENT</p> <p>SS6000 (10" x 14")</p>	 <p>DANGER KEEP OUT</p> <p>DANGER ACCÈS INTERDIT</p> <p>SS6001 (10" x 14")</p>	 <p>DANGER CHEMICAL STORAGE</p> <p>DANGER STOCKAGE DE PRODUITS CHIMIQUES</p> <p>SS6002 (10" x 14")</p>	 <p>DANGER HOT</p> <p>DANGER CHAUD</p> <p>SS6003 (10" x 14")</p>	 <p>DANGER FUEL STORAGE NO SMOKING</p> <p>DANGER STOCKAGE DE CARBURANT NE PAS FUMER</p> <p>SS6004 (10" x 14")</p>	 <p>DANGER FLAMMABLE MATERIALS</p> <p>DANGER MATIÈRES INFLAMMABLES</p> <p>SS6005 (10" x 14")</p>	 <p>DANGER HARD HATS ARE REQUIRED IN THIS AREA</p> <p>DANGER LES CASQUES PROTECTEURS SONT OBLIGATOIRES DANS CETTE ZONE</p> <p>SS6006 (10" x 14")</p>
--	---	---	---	---	---	---

 <p>WARNING AUTHORIZED PERSONNEL ONLY</p> <p>AVERTISSEMENT PERSONNEL AUTORISÉ SEULEMENT</p> <p>SS6014 (10" x 14")</p>	 <p>WARNING NO TRESPASSING</p> <p>AVERTISSEMENT ENTRÉE INTERDITE</p> <p>SS6015 (10" x 14")</p>	 <p>WARNING KEEP OUT HAZARD AREA</p> <p>AVERTISSEMENT ACCÈS INTERDIT ZONE DANGEREUSE</p> <p>SS6016 (10" x 14")</p>	 <p>WARNING HIGH VOLTAGE</p> <p>AVERTISSEMENT HAUTE TENSION</p> <p>SS6017 (10" x 14")</p>	 <p>WARNING NO SMOKING</p> <p>AVERTISSEMENT NE PAS FUMER</p> <p>SS6018 (10" x 14")</p>	 <p>WARNING FLAMMABLE MATERIALS</p> <p>AVERTISSEMENT MATIÈRES INFLAMMABLES</p> <p>SS6019 (10" x 14")</p>	 <p>WARNING HARD HATS ARE REQUIRED IN THIS AREA</p> <p>AVERTISSEMENT LES CASQUES PROTECTEURS SONT OBLIGATOIRES DANS CETTE ZONE</p> <p>SS6020 (10" x 14")</p>
---	--	--	---	---	--	--

 <p>CAUTION WATCH FOR LIFT TRUCKS</p> <p>ATTENTION ATTENTION AUX CHARIOTS ÉLEVATEURS</p> <p>SS6007 (10" x 14")</p>	 <p>CAUTION TRIPPING HAZARD</p> <p>ATTENTION RISQUE DE TRÉBUCHEMENT</p> <p>SS6008 (10" x 14")</p>	 <p>CAUTION SLIPPERY WHEN WET</p> <p>ATTENTION PLANCHER GLISSANT SI HUMIDE</p> <p>SS6009 (10" x 14")</p>	 <p>CAUTION CLEARANCE __ FT __ IN</p> <p>ATTENTION ZONE DÉGAGÉE __ PI __ PO</p> <p>SS6010 (10" x 14")</p>	 <p>CAUTION STAY BACK __ FT</p> <p>ATTENTION RESTER EN RETRAIT __ PIEDS</p> <p>SS6011 (10" x 14")</p>	 <p>CAUTION OPEN DOOR SLOWLY</p> <p>ATTENTION OUVRIR LA PORTE LENTEMENT</p> <p>SS6012 (10" x 14")</p>	 <p>CAUTION STARTS AUTOMATICALLY</p> <p>ATTENTION DÉMARRE AUTOMATIQUEMENT</p> <p>SS6013 (10" x 14")</p>
---	--	---	--	---	--	--

 <p>NOTICE EMPLOYEES ONLY</p> <p>AVIS EMPLOYÉS SEULEMENT</p> <p>SS6021 (10" x 14")</p>	 <p>NOTICE NO SMOKING</p> <p>AVIS NE PAS FUMER</p> <p>SS6022 (10" x 14")</p>	 <p>NOTICE NO PARKING</p> <p>AVIS STATIONNEMENT INTERDIT</p> <p>SS6023 (10" x 14")</p>	 <p>NOTICE KEEP THIS AREA CLEAR</p> <p>AVIS MAINTENIR CETTE ZONE DÉGAGÉE</p> <p>SS6024 (10" x 14")</p>	 <p>NOTICE CHAIN ALL CYLINDERS SECURELY</p> <p>AVIS ATTACHER SOLIDEMENT TOUTES LES BOUTEILLES</p> <p>SS6025 (10" x 14")</p>	 <p>NOTICE NO FOOD OR DRINK BEYOND THIS POINT</p> <p>AVIS NOURRITURE ET BOISSONS INTERDITES</p> <p>SS6026 (10" x 14")</p>	 <p>NOTICE PLEASE DEPOSIT ALL RUBBISH IN RECEPTACLES PROVIDED</p> <p>AVIS VEUILLEZ DÉPOSER TOUS LES DÉCHETS DANS LES RÉCIPENTS PRÉVUS</p> <p>SS6027 (10" x 14")</p>
---	---	---	---	---	--	--

 <p>SAFETY FIRST FIRST AID ROOM</p> <p>SÉCURITÉ D'ABORD SALLE DE PREMIERS SOINS</p> <p>SS6028 (10" x 14")</p>	 <p>SAFETY FIRST FIRST AID KIT</p> <p>SÉCURITÉ D'ABORD TROUSSE DE PREMIERS SOINS</p> <p>SS6029 (10" x 14")</p>	 <p>SAFETY FIRST EMERGENCY SHOWER</p> <p>SÉCURITÉ D'ABORD DOUCHE D'URGENCE</p> <p>SS6030 (10" x 14")</p>	 <p>SAFETY FIRST EMERGENCY EYE WASH STATION</p> <p>SÉCURITÉ D'ABORD DOUCHE/LAVE-YEUX D'URGENCE</p> <p>SS6031 (10" x 14")</p>	 <p>SAFETY FIRST REPORT ALL INJURIES AT ONCE</p> <p>SÉCURITÉ D'ABORD DÉCLARER TOUTES LES LÉSIONS</p> <p>SS6032 (10" x 14")</p>	 <p>SAFETY FIRST CARELESSNESS MAY COST A LIFE</p> <p>SÉCURITÉ D'ABORD UNE NÉGLIGENCE PEUT CÔÛTER LA VIE</p> <p>SS6033 (10" x 14")</p>	 <p>SAFETY FIRST THE SAFE WAY IS THE BEST WAY</p> <p>SÉCURITÉ D'ABORD OPTER POUR LA SÉCURITÉ EST LA RÈGLE D'OR</p> <p>SS6034 (10" x 14")</p>
--	---	---	---	--	--	---

Workplace Safety Signs French

Use these safety signs as a great way to communicate health and safety issues in a French language working environment. We offer a variety of different material types to meet all budgets and durability issues. We can also make any custom signs you require.



SAF1005 (7" x 10")
SSF1005 (10" x 14")
SCF1005 (14" x 20")

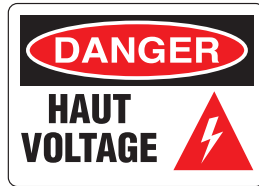

SAF1111 (7" x 10")
SSF1111 (10" x 14")
SCF1111 (14" x 20")



SAF1026 (7" x 10")
SSF1026 (10" x 14")
SCF1026 (14" x 20")



SAF1002 (7" x 10")
SSF1002 (10" x 14")
SCF1002 (14" x 20")



SAF1114 (7" x 10")
SSF1114 (10" x 14")
SCF1114 (14" x 20")



SAF1010 (7" x 10")
SSF1010 (10" x 14")
SCF1010 (14" x 20")



SAF1075 (7" x 10")
SSF1075 (10" x 14")
SCF1075 (14" x 20")



SAF1133 (7" x 10")
SSF1133 (10" x 14")
SCF1133 (14" x 20")



SAF1084 (7" x 10")
SSF1084 (10" x 14")
SCF1084 (14" x 20")



SAF1085 (7" x 10")
SSF1085 (10" x 14")
SCF1085 (14" x 20")



SAF1032 (7" x 10")
SSF1032 (10" x 14")
SCF1032 (14" x 20")



SAF1068 (7" x 10")
SSF1068 (10" x 14")
SCF1068 (14" x 20")



SAF1025 (7" x 10")
SSF1025 (10" x 14")
SCF1025 (14" x 20")



SAF1029 (7" x 10")
SSF1029 (10" x 14")
SCF1029 (14" x 20")



SAF1070 (7" x 10")
SSF1070 (10" x 14")
SCF1070 (14" x 20")



SAF2004 (7" x 10")
SSF2004 (10" x 14")
SCF2004 (14" x 20")



SAF2018 (7" x 10")
SSF2018 (10" x 14")
SCF2018 (14" x 20")



SAF2074 (7" x 10")
SSF2074 (10" x 14")
SCF2074 (14" x 20")



SAF2070 (7" x 10")
SSF2070 (10" x 14")
SCF2070 (14" x 20")



SAF2084 (7" x 10")
SSF2084 (10" x 14")
SCF2084 (14" x 20")



SAF4058 (7" x 10")
SSF4058 (10" x 14")
SCF4058 (14" x 20")



SAF4029 (7" x 10")
SSF4029 (10" x 14")
SCF4029 (14" x 20")



SAF4061 (7" x 10")
SSF4061 (10" x 14")
SCF4061 (14" x 20")



SAF4033 (7" x 10")
SSF4033 (10" x 14")
SCF4033 (14" x 20")



SAF4006 (7" x 10")
SSF4006 (10" x 14")
SCF4006 (14" x 20")



SAF5004 (7" x 10")
SSF5004 (10" x 14")
SCF5004 (14" x 20")



SAF5003 (7" x 10")
SSF5003 (10" x 14")
SCF5003 (14" x 20")



SAF5000 (7" x 10")
SSF5000 (10" x 14")
SCF5000 (14" x 20")



SAF5001 (7" x 10")
SSF5001 (10" x 14")
SCF5001 (14" x 20")



SAF5018 (7" x 10")
SSF5018 (10" x 14")
SCF5018 (14" x 20")

ANSI Safety Signs

ANSI format signs offer a great way to communicate critical health and safety information in your workplace. These signs display hazards and safety information in a consistent manner for effective communication. ANSI signs include information in both text and a visual pictogram to reinforce the message.

Choose from our variety of materials for the best fit for your particular application. Don't see the legend you need? Give us a call to see what we can do for your next sign requirement.

HOW TO ORDER:

SELECT SIGN - ANS1000 SELECT SIGN TYPE - V ADD TOGETHER - ANS1000V

SIGN ARMOR			
Weather, Chemical, Abrasion & Graffiti Resistant Coating			
V	P	A	MV
Adhesive VynMark	Semi-Rigid Plastic	Aluminum	Magnetic Sheeting

OVER-LAMINATION FILM		
High Performance Outdoor UV Film		
VL	PL	AL
Adhesive VynMark	Semi Rigid Plastic	Aluminum



ANS1000 (10" x 14")



ANS1001 (10" x 14")



ANS1002 (10" x 14")

ANSI DANGER SIGNS

"Are designed for use where major hazard situations present an immediate threat of death or serious injuries."
Source: ANSI spec Z535.4.4.14.1.

Consult local regulations for specific guidelines.



ANS1003 (10" x 14")



ANS1004 (10" x 14")



ANS1005 (10" x 14")



ANS1006 (10" x 14")

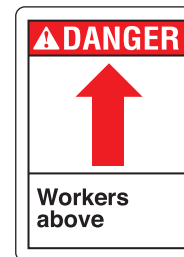

ANS1007 (10" x 14")



ANS1008 (10" x 14")



ANS1009 (10" x 14")

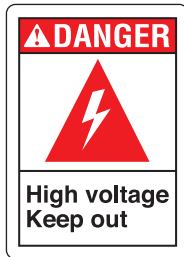

ANS1010 (10" x 14")



ANS1011 (10" x 14")



ANS1012 (10" x 14")



ANS1013 (10" x 14")



ANS1014 (10" x 14")



ANS1015 (10" x 14")



ANS1016 (10" x 14")



ANS1017 (10" x 14")

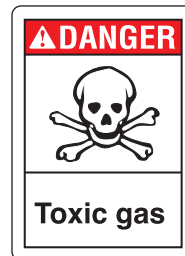

ANS1018 (10" x 14")



ANS1019 (10" x 14")



ANS1020 (10" x 14")

ANSI WARNING SIGNS

"Are designed for use where hazard situation that, if not avoided, could result in death or serious injuries."

Source: ANSI spec Z535.4.4.14.2.

Consult local regulations for specific guidelines.



ANS2002 (10" x 14")



ANS2003 (10" x 14")



ANS2004 (10" x 14")



ANS2005 (10" x 14")



ANS2000 (10" x 14")



ANS2001 (10" x 14")



ANS2006 (10" x 14")

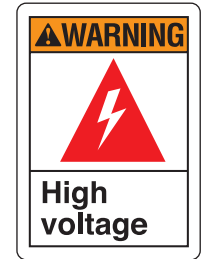

ANS2007 (10" x 14")



ANS2008 (10" x 14")



ANS2009 (10" x 14")



ANS2010 (10" x 14")



ANS2011 (10" x 14")



ANS2012 (10" x 14")



ANS2013 (10" x 14")

ANSI CAUTION SIGNS

"Indicate hazardous situations that, if not avoided, could result in minor or moderate injuries."

Source: ANSI spec Z535.4.4.14.3.

Consult local regulations for specific guidelines.



ANS3002 (10" x 14")



ANS3003 (10" x 14")



ANS3004 (10" x 14")



ANS3005 (10" x 14")



ANS3000 (10" x 14")



ANS3001 (10" x 14")



ANS3006 (10" x 14")



ANS3007 (10" x 14")



ANS3008 (10" x 14")



ANS3009 (10" x 14")



ANS3010 (10" x 14")



ANS3011 (10" x 14")



ANS3012 (10" x 14")



ANS3013 (10" x 14")

ANSI NOTICE SIGNS

"Indicates information considered important, but not hazard related."
 Source: ANSI spec Z535.4.4.14.4.

Consult local regulations for specific guidelines.



ANS4000 (10" x 14")



ANS4001 (10" x 14")



ANS4002 (10" x 14")



ANS4003 (10" x 14")



ANS4004 (10" x 14")



ANS4005 (10" x 14")



ANS4006 (10" x 14")



ANS4007 (10" x 14")



ANS4008 (10" x 14")



ANS4009 (10" x 14")



ANS4010 (10" x 14")



ANS4011 (10" x 14")



ANS4012 (10" x 14")



ANS4013 (10" x 14")

ANSI SAFETY SIGNS

"Indicates a type safety sign, or separate panel on safety sign, where specific safety-related instructions or procedures are described."
 Source: ANSI spec Z535.4.4.14.4.

Consult local regulations for specific guidelines.



ANS5000 (10" x 14")



ANS5001 (10" x 14")



ANS5002 (10" x 14")



ANS5003 (10" x 14")



ANS5004 (10" x 14")



ANS5005 (10" x 14")



ANS5006 (10" x 14")



ANS5007 (10" x 14")



ANS5008 (10" x 14")



ANS5009 (10" x 14")



ANS5010 (10" x 14")



ANS5011 (10" x 14")



ANS5012 (10" x 14")



ANS5013 (10" x 14")

CSA Compliant Safety Signs

CSA format signs to help communicate health and safety concerns and messages to your employees at your Canadian facilities. These signs incorporate a worded message that is reinforced with standardized graphics program, making this selection a great choice.

Choose from our variety of materials for the best fit for your particular application. Don't see the legend you need? Give us a call to see what we can do for your next sign requirement.

HOW TO ORDER:

SELECT SIGN - **CSA1000** SELECT SIGN TYPE - **V** ADD TOGETHER. - **CSA1000V**

SIGN ARMOR <i>Weather, Chemical, Abrasion & Graffiti Resistant Coating</i>		
V	P	MV
Adhesive VynMark	Semi-Rigid Plastic	Magnetic Sheeting

OVER-LAMINATION FILM <i>High Performance Outdoor UV Film</i>	
VL	PL
Adhesive VynMark	Semi Rigid Plastic

Regulatory Signs



Prohibition

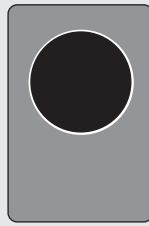

Mandatory



No entry

CSA1000 (8" x 12")

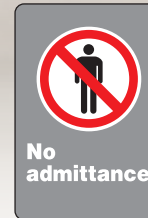

No admittance

CSA1001 (8" x 12")



Authorized personnel only

CSA1002 (8" x 12")



No entry to pedestrians

CSA1003 (8" x 12")



No food or drinks allowed

CSA1004 (8" x 12")



No smoking

CSA1005 (8" x 12")



Thank you for not smoking

CSA1006 (8" x 12")



No open flame

CSA1007 (8" x 12")



No lighters allowed

CSA1008 (8" x 12")



No jewelry allowed

CSA1009 (8" x 12")



No jewelry allowed

CSA1010 (8" x 12")



In case of fire do not use the elevator

CSA1011 (8" x 12")



Do not obstruct

CSA1012 (8" x 12")



Do not touch

CSA1013 (8" x 12")



No industrial vehicles

CSA1014 (8" x 12")



Safety helmet mandatory

CSA1015 (8" x 12")



Safety glasses mandatory

CSA1016 (8" x 12")



Safety helmet and glasses mandatory

CSA1017 (8" x 12")



Safety goggles mandatory

CSA1018 (8" x 12")



Safety visor mandatory

CSA1019 (8" x 12")



Safety glasses and visor mandatory

CSA1020 (8" x 12")



Safety visor mandatory

CSA1021 (8" x 12")



Gloves mandatory

CSA1022 (8" x 12")



Safety footwear mandatory

CSA1023 (8" x 12")



Rubber boots mandatory

CSA1024 (8" x 12")



Hearing protectors mandatory

CSA1025 (8" x 12")



Respirator mandatory

CSA1026 (8" x 12")



Cartridge respirator mandatory

CSA1027 (8" x 12")



Self-contained breathing apparatus mandatory

CSA1028 (8" x 12")



Protective apron mandatory
CSA1029 (8" x 12")



Protective clothing mandatory
CSA1030 (8" x 12")



Smock mandatory
CSA1031 (8" x 12")



Hair protection mandatory
CSA1032 (8" x 12")



Life jacket mandatory
CSA1033 (8" x 12")



Wash your hands
CSA1034 (8" x 12")



Use pedestrian walkway
CSA1035 (8" x 12")



Report all injuries
CSA1036 (8" x 12")



Keep Locked
CSA1037 (8" x 12")



Attach gas cylinders
CSA1038 (8" x 12")



Use pedestrian door
CSA1039 (8" x 12")



Chock wheels mandatory
CSA1040 (8" x 12")



Chock wheels mandatory
CSA1041 (8" x 12")



Keep this door closed
CSA1042 (8" x 12")

Warning Signs

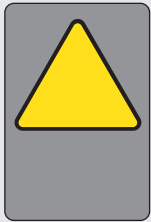

Caution



Danger



Caution pedestrian crossing
CSA3000 (8" x 12")



Caution moving load
CSA3001 (8" x 12")



Caution look-out for crane
CSA3002 (8" x 12")



Caution risk of collision
CSA3003 (8" x 12")



Caution automatic starting equipment
CSA3004 (8" x 12")



Caution infectious substances
CSA3005 (8" x 12")



Caution self-closing fire door
CSA3006 (8" x 12")



Caution industrial vehicle traffic
CSA3007 (8" x 12")



Caution watch your step
CSA3008 (8" x 12")



Caution slippery surface
CSA3009 (8" x 12")



Caution falling objects
CSA3010 (8" x 12")



Caution radioactive materials
CSA3011 (8" x 12")



Caution hot surface
CSA3012 (8" x 12")



Caution hand hazard
CSA3013 (8" x 12")



Caution laser hazard
CSA3014 (8" x 12")



Danger flammable materials
CSA5000 (8" x 12")



Danger combustible materials
CSA5001 (8" x 12")



Danger oxidizer
CSA5002 (8" x 12")



Danger toxic substances
CSA5003 (8" x 12")



Danger corrosive materials
CSA5004 (8" x 12")



Danger chemical products
CSA5005 (8" x 12")



Danger burning hazard
CSA5006 (8" x 12")



Danger pinch point
CSA5007 (8" x 12")



Danger cutting hazard
CSA5008 (8" x 12")



Danger crushing hazard
CSA5009 (8" x 12")



Danger explosive
CSA5010 (8" x 12")



Danger high voltage
CSA5011 (8" x 12")



Danger of electrocution
CSA5012 (8" x 12")



Danger no cellular phone
CSA5013 (8" x 12")

Information Signs

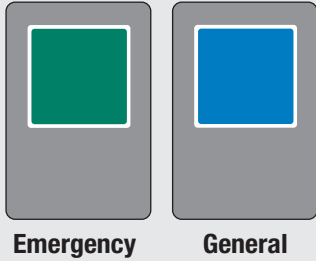

Emergency

General



CSA7000 (8" x 12")



CSA7001 (8" x 12")



CSA7002 (8" x 12")



CSA7003 (8" x 12")



CSA7004 (8" x 12")



CSA7005 (8" x 12")



CSA7006 (8" x 12")



CSA7007 (8" x 12")



CSA7008 (8" x 12")



CSA7009 (8" x 12")



CSA7010 (8" x 12")



CSA7011 (8" x 12")



CSA7012 (8" x 12")

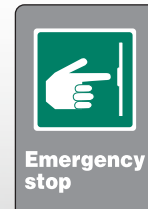

CSA7013 (8" x 12")



CSA7014 (8" x 12")



CSA9000 (8" x 12")



CSA9001 (8" x 12")



CSA9002 (8" x 12")



CSA9003 (8" x 12")



CSA9004 (8" x 12")



CSA9005 (8" x 12")



CSA9006 (8" x 12")



CSA9007 (8" x 12")

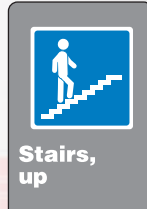

CSA9008 (8" x 12")



CSA9009 (8" x 12")



CSA9010 (8" x 12")

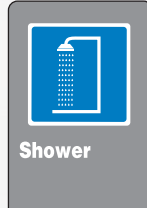

CSA9011 (8" x 12")



CSA9012 (8" x 12")



ISO International Safety Signs

The internationally recognized symbols used on these signs communicate information and safety tips to anyone around your workplace. These signs meet ISO (International Organization for Standardization) standards for symbols and colors.

Available in 6" or 12" diameter sizes and Adhesive VynMark or Rigid Plastic.

HOW TO ORDER:

SELECT SIGN - **IS1000** SELECT SIGN TYPE - **V** ADD TOGETHER - **IS1000V**

SIGN ARMOR	<i>Weather, Chemical, Abrasion & Graffiti Resistant Coating</i>	
	V	P
	Adhesive VynMark	Semi-Rigid Plastic

Mandatory Take action to avoid the hazard

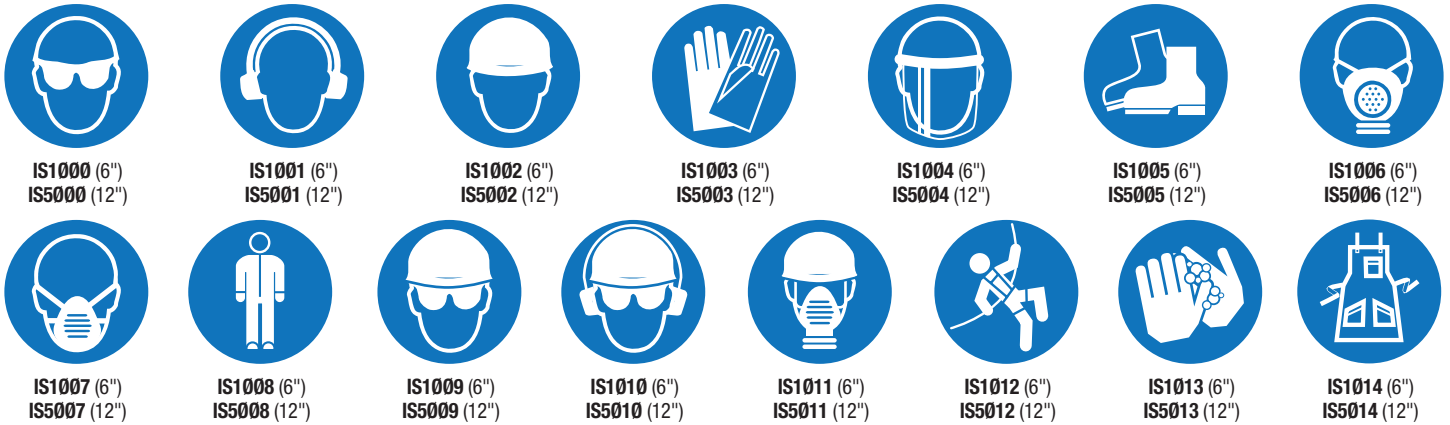

Prohibited Forbid an action to avoid the hazard

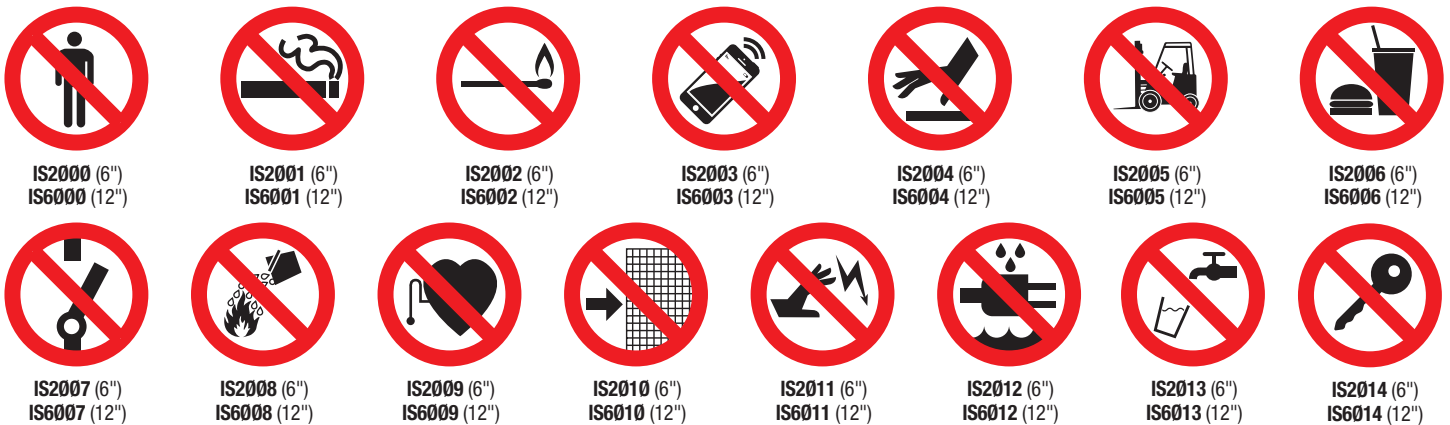

Warning Identify the hazard to avoid



Facility & Parking Signs

Make customers and visitors aware of driving and parking restrictions with our full line of parking signs. Mark parking lots, lane ways and other areas clearly and professionally with our wide variety of legends.

All signs are 12" x 18" and made from 0.050" Aluminum with 4 mil UV protective lamination. They come with 2 pre-drilled holes centered top and bottom for an easy install on posts or walls. Consult local regulations regarding specific guidelines.

Choose from standard Aluminum or Reflective Aluminum for the best fit for your particular application. Don't see the legend you need? Give us a call to see what we can do for your next sign requirement.

HOW TO ORDER:

SELECT SIGN - PSS1000 SELECT SIGN TYPE - A ADD TOGETHER - PSS1000A

SIGN ARMOR Weather, Chemical, Abrasion & Graffiti Resistant Coating
A
 Aluminum

OVER-LAMINATION FILM High Performance Outdoor UV Film
RF
 Reflective Aluminum



Fire Safety & Emergency Equipment

Projected Signs

Our projected safety signs offer 2 way viewing that makes it easier for your employees to spot safety and fire suppression equipment locations. Check with local codes and by-laws prior to use.

Don't see the legend you need? Give us a call to see what we can do for your next sign requirement.

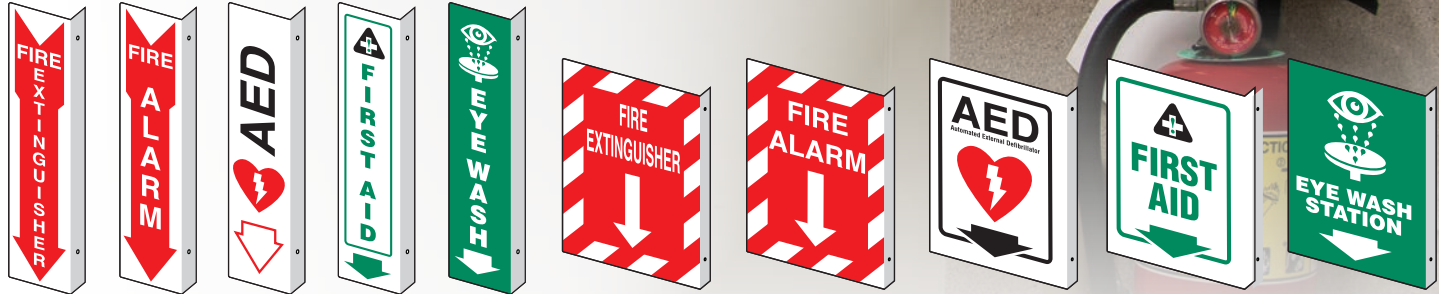

DFS1Ø9P
(4" x 18")

DFS11ØP
(4" x 18")

DFS135P
(4" x 18")

DFS136P
(4" x 18")

DFS137P
(10" x 14")

DFS1Ø4P
(10" x 14")

DFS1Ø5P
(10" x 14")

DFS138P
(10" x 14")

DFS139P
(10" x 14")

DFS14ØP
(10" x 14")



DFS111P (5" x 6")



DFS112P (5" x 6")



DFS113P (5" x 6")

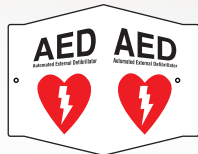

DFS141P (5" x 6")



DFS142P (5" x 6")



DFS143P (5" x 6")

Fire Safety Bulk Signs

Looking for a cost effective way to mark fire safety features and equipment? Our bulk fire safety signs are made from a 10 point semi-rigid plastic or adhesive VynMark with a protective over-lamination to offer years of indoor service. These signs can be easily mounted to most any surface. Check with Federal, state and local guidelines on the use of EXIT signage in your region.

All signs are 10" x 14". Packaged in 50 signs per package for best value. Custom colors and legends available on orders of 250+ signs.



DFS1ØØP5Ø
DFS1ØØV5Ø
(10" x 14")



DFS1Ø1P5Ø
DFS1Ø1V5Ø
(10" x 14")



DFS1Ø2P5Ø
DFS1Ø2V5Ø
(10" x 14")



DFS1Ø3P5Ø
DFS1Ø3V5Ø
(10" x 14")



DFS1Ø6P5Ø
DFS1Ø6V5Ø
(4" x 18")



DFS1Ø7P5Ø
DFS1Ø7V5Ø
(4" x 18")



DFS1Ø8P5Ø
DFS1Ø8V5Ø
(4" x 18")

Fire Safety & Emergency Equipment

Signs

Make the location of safety and fire suppression equipment clear to employees with our full line of fire equipment signs.

Choose from our variety of materials for the best fit for your particular application. Don't see the legend you need? Give us a call to see what we can do for your next sign requirement. Check with local codes by-laws prior to use.

HOW TO ORDER:

SELECT SIGN - **DFS100** SELECT SIGN TYPE - **V** ADD TOGETHER. - **DFS100V**

SIGN ARMOR		Weather, Chemical, Abrasion & Graffiti Resistant Coating		
V	P	VG	PG	
Adhesive VynMark	Semi-Rigid Plastic	Glow-in-the-dark Adhesive VynMark	Glow-in-the-dark Semi-Rigid Plastic	



DFS106 (4" x 18")



DFS107 (4" x 18")



DFS108 (4" x 18")



DFS144 (4" x 18")



DFS145 (4" x 18")



DFS146 (4" x 18")



DFS101 (10" x 14")



DFS102 (10" x 14")



DFS103 (10" x 14")



DFS114 (10" x 14")

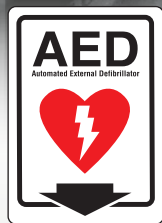

DFS147 (10" x 14")



DFS148 (10" x 14")



DFS149 (10" x 14")



DFS127 (10" x 14")



DFS128 (10" x 14")



DFS129 (10" x 14")



DFS130 (10" x 14")



DFS100 (10" x 14")



DFS125 (10" x 14")

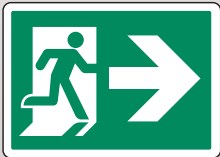

DFS126 (10" x 14")

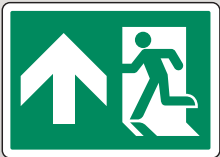

DFS131 (10" x 14")



DFS132 (10" x 14")

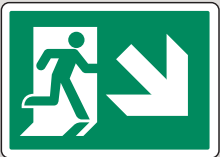

DFS123 (10" x 14")

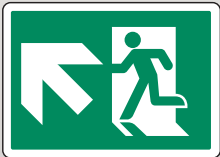

DFS124 (10" x 14")



DFS121 (10" x 14")

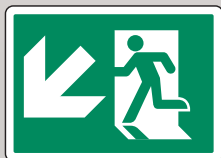

DFS122 (10" x 14")



DFS133 (10" x 14")

Check with local, state/provincial and federal authorities to determine suitability of this photoluminescent product in any egress or emergency exit applications.

Stencil Floor Sign

Use our Floor Marking stencils to paint permanent messages in your facilities. These durable and reusable stencils are easy to use and provide professional looking images for your floors or walls. Stencils are made with 0.055" HDPE with 20" images.



Custom stencils available. Call for details.



SFM100

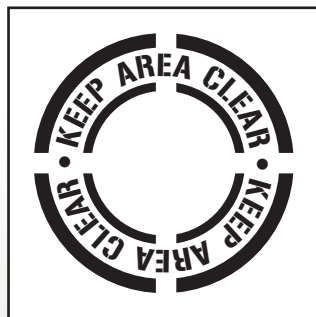

SFM101



SFM102

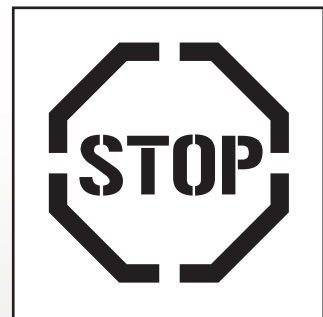

SFM103



SFM104



SFM105



SFM106



SFM107

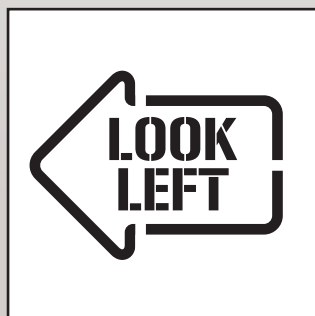

SFM108



SFM109



SFM110



SFM111

Safety Floor Signs

Bring attention and a slip-resistant surface to most any floor surface to help improve the safety of your workplace. These brightly colored floor graphics have an embossed resilient coating and a permanent adhesive backing. Simple remove the backing liner to expose the adhesive for application.

Standard size is 6" x 24" with custom legends and sizes available.



ANTI-SLIP SURFACE



FS3001V	FS3002V	FS3003V	FS3004V
FS3005V	FS3006V	FS3007V	FS3008V
FS3009V	FS3010V	FS3011V	FS3012V
FS3013V	FS3014V	FS3015V	FS3016V
FS3017V	FS3018V	FS3019V	FS3020V
FS3021V	FS3022V	FS3023V	FS3024V
FS3025V	FS3026V	FS3027V	FS3028V
FS3029V	FS3030V	FS3031V	FS3032V
FS3033V	FS3034V	FS3035V	FS3036V

Floor Signs Anti-Slip

These high visibility graphic floor signs provide a constant reminder to your employees about important Workplace Hazard, Safety Requirement and General Notice information details. Constructed from a high quality adhesive VynMark stock, we laminate a thick textured material to these signs for added durability as well as slip resistance. The sub-surface printed images provide extended durability and will stand up to heavy pedestrian traffic. The aggressive adhesive will adhere to most smooth, clean and dry floors. These signs have a maximum diameter or length of 17".



ANTI-SLIP SURFACE

Glow-in-the-dark Floor Signs Anti-Slip

Enhance your emergency exit routing with our photoluminescent floor signs. These signs have a textured surface for slip resistance and our Glow-in-the-dark material for visibility in low light conditions.

The clear graphics are easily understood and are highly visible. Our luminous signs will maintain visibility to the light adjusted eye for up to 6 hours. These signs have a maximum diameter or length of 17".

MEETS OR EXCEEDS STANDARDS:

- DIN 67510
- ASTM E2072-14
- ISO 15370
- EU Marine Equipment Directive
- IMO Resolution A. 752 (18)
- PSPA class B





Door Swing Floor Sign Anti-Slip

Helps eliminate an often overlooked safety hazard. This "Door Swing" graphic will clearly remind people of the swing area and prevent the potential of injury from opening doors. This floor graphic is based on a 34" swing radius area.

Custom sizes/text also available. Contact customer service for details.



FS1043 - 34" x 34"



FS1040V



FS1006V



FS1023V



FS1004V



FS1038V



FS1000V



FS1025V



FS1001V



FS1039V



FS1017V



FS1005V



FS1018V



FS1021V



FS1016V



FS1041V



FS1011V



FS1009V



FS1012V



FS1010V



FS1011GL



FS1012GL



FS1009GL



FS1010GL



FS1018GL



FS1005GL



FS1004GL



FS1008GL



Check with local, state/provincial and federal authorities to determine suitability of this photoluminescent product in any egress or emergency exit applications.

ArmorStripe

Ultra Durable Floor Signs

ArmorStripe offers an extremely durable system to aid in floor safety signage. These products are made from an ultra durable plastic without the use of print. This special process ensure that the image will remain legible through the entire life of the floor signing system.

These floor signs are made from a through-color solid 0.055" thick rigid polyethylene surface with an ultra tacky heavy coat weight adhesive backing. They will adhere to most any clean smooth surface with a very high tack bond while offering a low residue removal from most applications. Complies with ANSI B101.1 SCOF (Dry) and ANSI A137.1 (Dry) for use in dry floor applications.

Available in an assortment of stock sizes and colors with custom options available.



ARMOR
STRIP E

CUSTOMIZE
this product ✓



HARD

HAT

ASM3000

Size: 17" x 17"



SAFETY

FOOTWEAR

ASM3001

Size: 17" x 17"



SAFETY

GLASSES

ASM3002

Size: 17" x 17"



HEARING

PROTECTION

ASM3003

Size: 17" x 17"



WATCH

YOUR STEP

ASM3004

Size: 17" x 17"



FORKLIFT

TRAFFIC

ASM3005

Size: 17" x 17"



LOOK
LEFT

ASM3006

Size: 17" x 17"



LOOK
RIGHT

ASM3007

Size: 17" x 17"



YIELD

ASM3008

Size: 17" x 17"



STOP

ASM3009

Size: 17" x 17"



SLOW

ASM3010

Size: 17" x 17"



EXIT

ASM3011

Size: 17" x 17"



ASM3012

Size: 17" x 17"

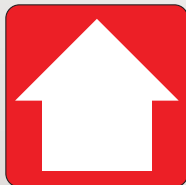

ASM3013

Size: 17" x 17"



PED
X-ING

ASM3014

Size: 17" x 17"



AUTHORIZED

PERSONNEL

ASM3015

Size: 17" x 17"



KEEP

CLEAR

ASM3016

Size: 17" x 17"



ASM3017

Size: 17" x 17"



CAUTION

ASM3018

Size: 23" x 35"



SLOW

ASM3019

Size: 23" x 35"



PED
X-ING

ASM3020

Size: 23" x 35"

A-Frame

Standing Floor Signs

The A-Frame standing floor sign is the best way to give a clear warning of a temporary hazard or communicate a message to pedestrian traffic. Printed both sides so the message is clearly visible from both directions and made from durable lightweight plastic. These signs are easily portable and can be positioned on any flat surface when needed. The A-Frame design provides a sturdy platform that is difficult to knock over. This design also allows the user to collapse the sign and lay flat for easy storage when not in use.

Don't see the message you need? Contact us with the details and we will print the wording you require.

Sign measures 12" wide x 19" tall

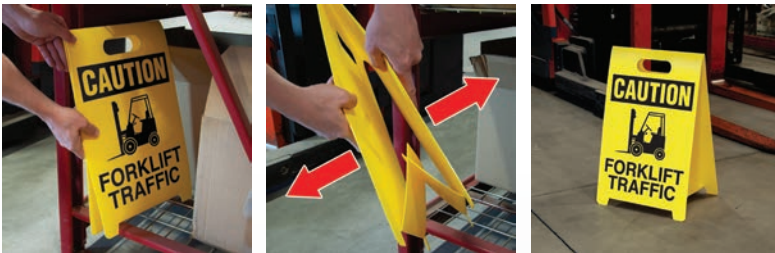

ASF1000



ASF1001



ASF1002



ASF1003



ASF1004



ASF1005



ASF1006



ASF1007



ASF1008



ASF1009



ASF1010



ASF1011

General Information Signs

We offer a wide selection of general information signs that provide directions, safety guidelines and general use information to people within your facility.

Choose from our variety of materials for the best fit for your particular application. Don't see the legend you need? Give us a call to see what we can do for your next sign requirement.

HOW TO ORDER:

SELECT SIGN - **SS5000** SELECT SIGN TYPE - **V** ADD TOGETHER. - **SS5000V**

SIGN ARMOR			
Weather, Chemical, Abrasion & Graffiti Resistant Coating			
V	P	A	MV
Adhesive VynMark	Semi-Rigid Plastic	Aluminum	Magnetic Sheeting

OVER-LAMINATION FILM		
High Performance Outdoor UV Film		
VL	PL	AL
Adhesive VynMark	Semi Rigid Plastic	Aluminum



SA5052 (7" x 10")
SS5052 (10" x 14")
SC5052 (14" x 20")



SA5053 (7" x 10")
SS5053 (10" x 14")
SC5053 (14" x 20")



SA5054 (7" x 10")
SS5054 (10" x 14")
SC5054 (14" x 20")



SA5055 (7" x 10")
SS5055 (10" x 14")
SC5055 (14" x 20")



SA5056 (7" x 10")
SS5056 (10" x 14")
SC5056 (14" x 20")



SA5057 (7" x 10")
SS5057 (10" x 14")
SC5057 (14" x 20")



SA5058 (7" x 10")
SS5058 (10" x 14")
SC5058 (14" x 20")



SA5059 (7" x 10")
SS5059 (10" x 14")
SC5059 (14" x 20")



SA5060 (7" x 10")
SS5060 (10" x 14")
SC5060 (14" x 20")



SA5061 (7" x 10")
SS5061 (10" x 14")
SC5061 (14" x 20")



SA5062 (7" x 10")
SS5062 (10" x 14")
SC5062 (14" x 20")



SA5063 (7" x 10")
SS5063 (10" x 14")
SC5063 (14" x 20")



SA5064 (7" x 10")
SS5064 (10" x 14")
SC5064 (14" x 20")



SA5065 (7" x 10")
SS5065 (10" x 14")
SC5065 (14" x 20")



SA5066 (7" x 10")
SS5066 (10" x 14")
SC5066 (14" x 20")



SA5067 (7" x 10")
SS5067 (10" x 14")
SC5067 (14" x 20")



SA5068 (7" x 10")
SS5068 (10" x 14")
SC5068 (14" x 20")



SA5069 (7" x 10")
SS5069 (10" x 14")
SC5069 (14" x 20")



SA5070 (7" x 10")
SS5070 (10" x 14")
SC5070 (14" x 20")



SA5071 (7" x 10")
SS5071 (10" x 14")
SC5071 (14" x 20")



SA5072 (7" x 10")
SS5072 (10" x 14")
SC5072 (14" x 20")



SA5073 (7" x 10")
SS5073 (10" x 14")
SC5073 (14" x 20")



SA5074 (7" x 10")
SS5074 (10" x 14")
SC5074 (14" x 20")



SA5075 (7" x 10")
SS5075 (10" x 14")
SC5075 (14" x 20")



SA5076 (7" x 10")
SS5076 (10" x 14")
SC5076 (14" x 20")



SA5077 (7" x 10")
 SS5077 (10" x 14")
 SC5077 (14" x 20")



SA5078 (7" x 10")
 SS5078 (10" x 14")
 SC5078 (14" x 20")



SA5079 (7" x 10")
 SS5079 (10" x 14")
 SC5079 (14" x 20")



SA5080 (7" x 10")
 SS5080 (10" x 14")
 SC5080 (14" x 20")



SA5081 (7" x 10")
 SS5081 (10" x 14")
 SC5081 (14" x 20")



SA5082 (7" x 10")
 SS5082 (10" x 14")
 SC5082 (14" x 20")



SA5083 (7" x 10")
 SS5083 (10" x 14")
 SC5083 (14" x 20")



SA5084 (7" x 10")
 SS5084 (10" x 14")
 SC5084 (14" x 20")



SA5085 (7" x 10")
 SS5085 (10" x 14")
 SC5085 (14" x 20")



SA5086 (7" x 10")
 SS5086 (10" x 14")
 SC5086 (14" x 20")



SA5087 (7" x 10")
 SS5087 (10" x 14")
 SC5087 (14" x 20")



SA5088 (7" x 10")
 SS5088 (10" x 14")
 SC5088 (14" x 20")



SA5089 (7" x 10")
 SS5089 (10" x 14")
 SC5089 (14" x 20")



SA5090 (7" x 10")
 SS5090 (10" x 14")
 SC5090 (14" x 20")



SA5091 (7" x 10")
 SS5091 (10" x 14")
 SC5091 (14" x 20")

CUSTOM SIGNS

Custom Sign Options

Call for details

Unable to find the sign you need to communicate your message in our wide variety of off-the-shelf signs? Give us a call to see what we can do for your next sign requirement.

What are safety tags?

Used to effectively communicate important safety messages to employees and visitors

Hazard and safety communications are essential in the workplace. Safety Tags help Identify hazards by the signal words DANGER, WARNING, CAUTION, or NOTICE. ANSI-style tags most often include specific details about the nature of the hazard, the consequence of interaction with the hazard, and avoidance procedures. Product manufacturers and facility owners in a wide array of industries use the ANSI Z535 standards in their efforts to assure a safer workplace.

The ANSI Z535 standards are often cited as the state-of-the-art benchmark against which safety markings and their adequacy are judged.



Common uses for safety tags

- Lock Out/Tag Out
- Hazard Control
- Electric shock hazards
- Machine repair
- Physical hazards
- Chemical or biological hazards
- Construction sites
- Manufacturing
- Fire Suppression Equipment





HOW TO CHOOSE Safety Tags



PT Grade

This is our most economical option in safety tags. Made from a 10-mil (0.010") stock that is a good choice for indoor or limited use outdoor applications. Stock is waterproof and can be written on with pencil, ball point pen or marker. Available in packages of 25, or by the roll for best value.

RP Grade

Our RP series safety tags are an upgrade on the PT material. Made with a thicker waterproof 15-mil (0.015") material which can be written on with pencil, ball point pen or marker. This grade also has a metal grommet for added hole strength.

RL Grade

The RL grade is our toughest and most durable option at 20-mil (0.020"). Our DuraPly stock is covered with a thick over laminated and affixed with a heavy duty 3/8" diameter metal grommet for extra strength. Tags are suited for both indoor and outdoor applications, and may be written on with marker or pen. This option will also meet a 50-lb pull test for lockout/tagout applications.

Custom Options

Unable to find the tag you need to communicate your message in our wide variety of off-the-shelf tags? Let us help you design the exact tag you will need for your application. Our tag production capabilities offer a wide range of design, print and finishing options. With our state-of-the-art digital printing we are able to produce cost effective, rapid delivery tags to meet the needs of any application.

Give us a call to see what we can do for your next tag requirement.



DANGER OSHA Workplace Tags

It is the sole responsibility of the user to determine the suitability of this product for their application, including, but not limited to, identifying the risk and its classification. When in doubt consult a qualified professional.

We offer 3 different material types to meet all budgets and durability issues. All tags are printed on both sides with state of the art digital printing and come 25 per pack. Don't see the legend you need? Give us a call to see what we can do for your next tag requirement.



Back print

HOW TO ORDER:

SELECT TAG - TG1000	SELECT TAG TYPE - PT	ADD TOGETHER. - TG1000PT	RL
	PT	RP	RL
	10-mil Poly Tag 3/8" diameter drilled hole.	15-mil Rigid DuraPly 3/8" diameter metal grommet to add strength.	20-mil Rigid Laminated DuraPly 3/8" diameter large grommet for extra strength.





TG1024

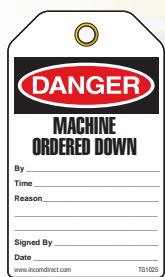

TG1025

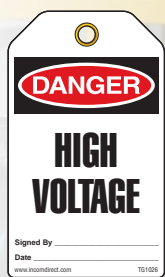

TG1026



TG1027



TG1028



TG1029



TG1030



TG1031

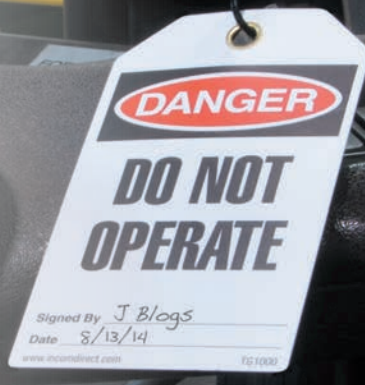

TG1032



TG1033



TG1034



TG1035



TG1036



TG1037



TG1038



TG1039



TG1040



TG1041



TG1042



TG1043



TG1044



TG1045



TG1046



TG1047



TG1048



TG1049



TG1050



TG1051



TG1052



TG1053



TG1054



TG1055



Self Laminating Tags

Page 105

Designed with a thick 2 mil clear protective laminating flap, these tags allow you to protect written messages from smudging or wearing off.

DURABILITY





TG1080



TG1081



TG1082



TG1083



TG1084



TG1085



TG1086



TG1087



TG1088



TG1089



TG1090



TG1091



TG1092



TG1093



TG1094



TG1095



TG1096



TG1097



TG1098



TG1099



TG1100



TG1101



TG1102



TG1103



TG1104



TG1105



TG1106



TG1107



TG1108



TG1109



TG1110



TG1111



TG1112



TG1113



TG1114



TG1115

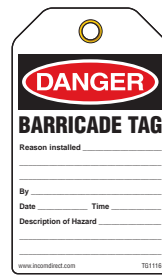

TG1116

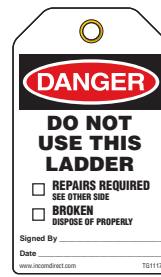

TG1117



TG1118



TG1119

WARNING OSHA Workplace Tags

It is the sole responsibility of the user to determine the suitability of this product for their application, including, but not limited to, identifying the risk and its classification. When in doubt consult a qualified professional.

We offer 3 different material types to meet all budgets and durability issues. All tags are printed on both sides with state of the art digital printing and come 25 per pack. Don't see the legend you need? Give us a call to see what we can do for your next tag requirement.

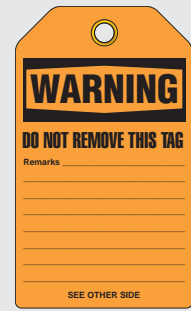

Back print

HOW TO ORDER:

SELECT TAG - TG4000	SELECT TAG TYPE - PT	ADD TOGETHER. - TG4000PT	RP	RL
	PT			
	10-mil Poly Tag 3/8" diameter drilled hole.		15-mil Rigid DuraPly 3/8" diameter metal grommet to add strength.	20-mil Rigid Laminated DuraPly 3/8" diameter large grommet for extra strength.

The following table lists the 32 warning tag models and their messages:

Model	Message
TG4000	FLAMMABLE
TG4001	DEFECTIVE DO NOT USE
TG4002	DO NOT OPERATE THIS EQUIPMENT
TG4003	DO NOT MOVE THIS EQUIPMENT
TG4004	HIGH VOLTAGE
TG4005	KEEP OUT
TG4006	UNSAFE DO NOT USE
TG4007	DO NOT REMOVE THIS TAG
TG4008	DO NOT THROW SWITCH
TG4009	READ INSTRUCTIONS BEFORE OPERATING
TG4010	____ VOLTS
TG4011	DISCONNECT MACHINE BEFORE SERVICING
TG4012	MAY RETAIN STATIC CHARGE
TG4013	DO NOT CLOSE THIS VALVE
TG4014	DO NOT OPEN THIS VALVE
TG4015	SHOCK HAZZARD
TG4016	MOVING PARTS
TG4017	MISUSE MAY CAUSE SERIOUS INJURY
TG4018	AUTHORIZED PERSONNEL ONLY
TG4019	HIGH HEAT
TG4020	DO NOT TOUCH
TG4021	DO NOT TURN ON
TG4022	MISUSE CAN CAUSE INJURY
TG4023	DO NOT OPEN
TG4024	CONTENTS UNDER PRESSURE
TG4025	HIGH PRESSURE BLOWOUT VALVE



EASY REFERENCE

Inspection Tags

Page 114-115

Inspection tags are designed to record and document equipment and machinery inspection, servicing and maintenance events for easy reference.

CAUTION OSHA Workplace Tags

It is the sole responsibility of the user to determine the suitability of this product for their application, including, but not limited to, identifying the risk and its classification. When in doubt consult a qualified professional.

We offer 3 different material types to meet all budgets and durability issues. All tags are printed on both sides with state of the art digital printing and come 25 per pack. Don't see the legend you need? Give us a call to see what we can do for your next tag requirement.



Back print

HOW TO ORDER:

SELECT TAG - TG3000	SELECT TAG TYPE - PT	ADD TOGETHER. - TG3000PT	RL
	PT	RP	RL
	10-mil Poly Tag 3/8" diameter drilled hole.	15-mil Rigid DuraPly 3/8" diameter metal grommet to add strength.	20-mil Rigid Laminated DuraPly 3/8" diameter large grommet for extra strength.





TG3024



TG3025

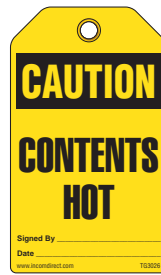

TG3026



TG3027



TG3028



TG3029



TG3030



TG3031



TG3032



TG3033



TG3034



TG3035

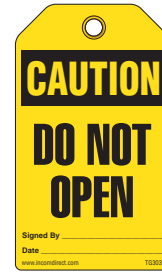

TG3036



TG3037



TG3038



TG3039



TG3040



TG3041



TG3042



TG3043



TG3044



TG3045



TG3046



TG3047

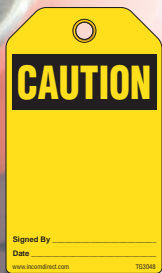

TG3048



TG3049



TG3050



TG3051



NOTICE Workplace Tags

It is the sole responsibility of the user to determine the suitability of this product for their application, including, but not limited to, identifying the risk and its classification. When in doubt consult a qualified professional.

We offer 3 different material types to meet all budgets and durability issues. All tags are printed on both sides with state of the art digital printing and come 25 per pack. Don't see the legend you need? Give us a call to see what we can do for your next tag requirement.

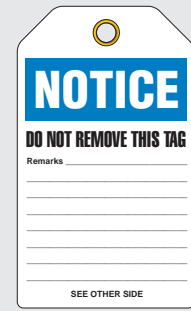

Back print

HOW TO ORDER:

SELECT TAG - TG5000	SELECT TAG TYPE - PT	ADD TOGETHER. - TG5000PT
	PT	RP
	10-mil Poly Tag 3/8" diameter drilled hole.	15-mil Rigid DuraPly 3/8" diameter metal grommet to add strength.
		RL
		20-mil Rigid Laminated DuraPly 3/8" diameter large grommet for extra strength.

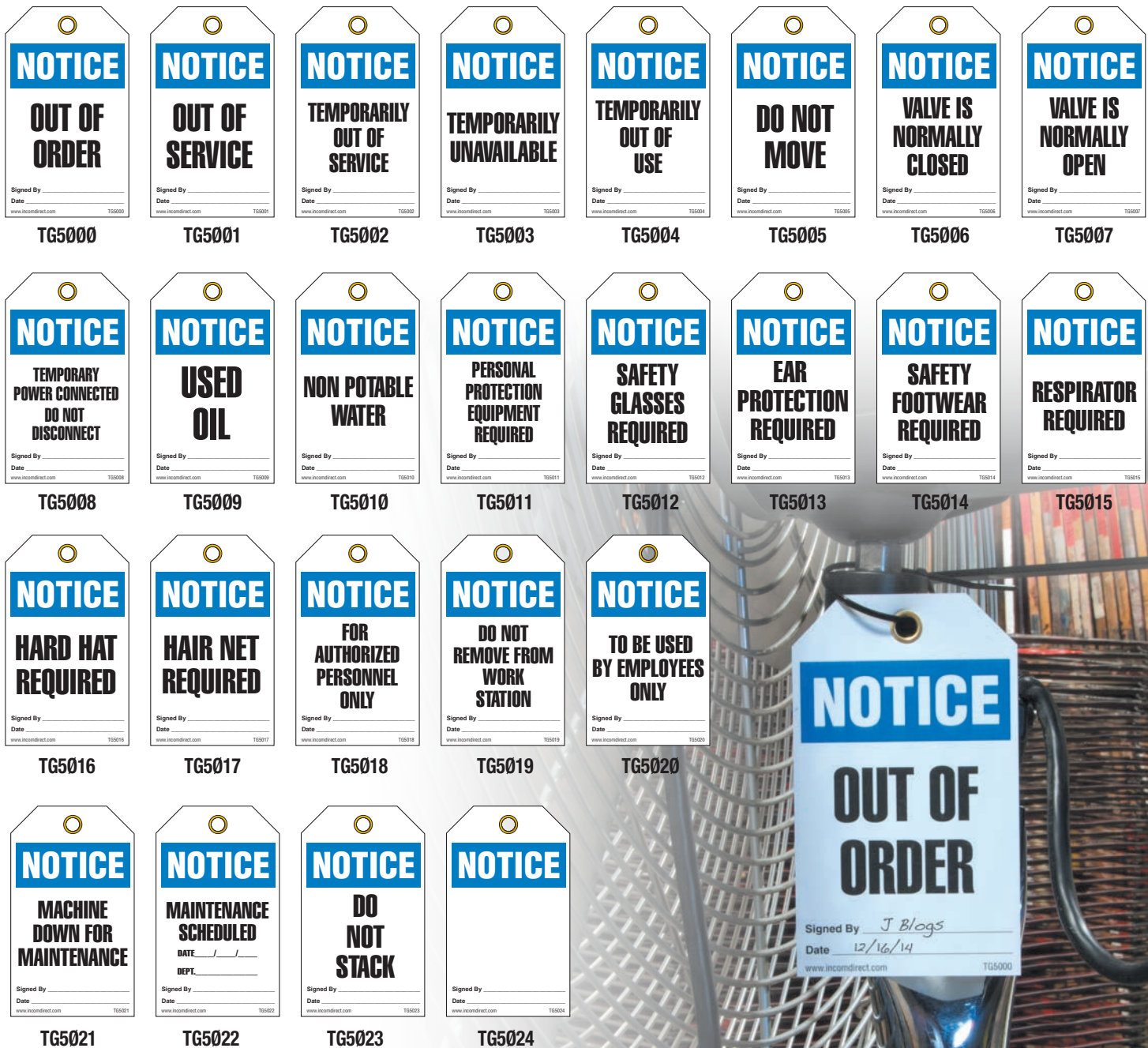

Self Laminating Tags Durability & Convenience

Our stock self laminating tags offer an easy way to protect the information on your tags. Designed with a thick 2 mil clear protective laminating flap, these tags are a highly durable option for use in your facility. Simply write in the required information, peel off the backing from the lamination flap and seal the tag. Once sealed, the information on your tag will be protected from dirt abrasion or chemical splashes. Also a great way to prevent further changes to the tag once it is put into use.

Tags are made from a durable 15 mil stock and measure 3-3/8" x 5-3/4". Sold in packages of 24 with 3/8" eyelet.



1 Identify the hazard and write your message.



2 Peel back the liner while applying the lamination.



3 Communicate the hazard quickly and effectively with no smudging or wearing on text.



SLM100



SLM101



SLM102

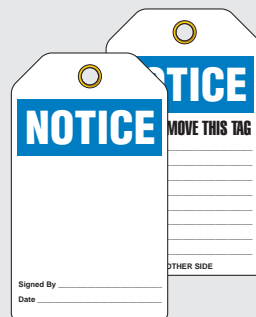

SLM103

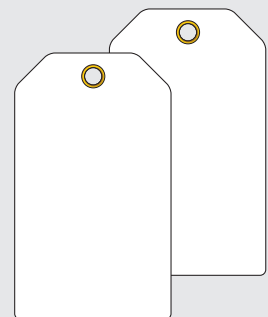

SLM104

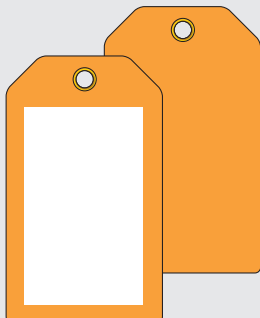

SLM105

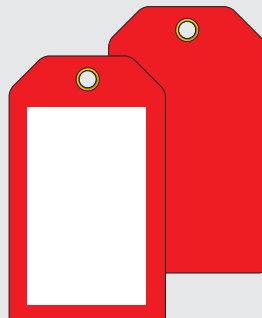

SLM106

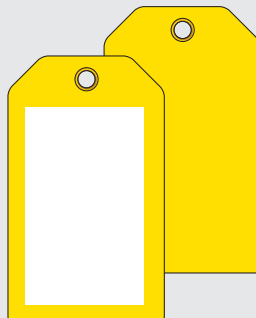

SLM107

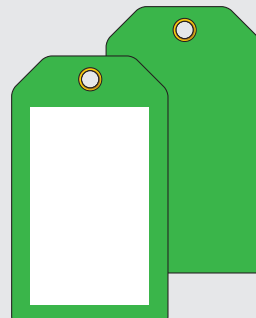

SLM108

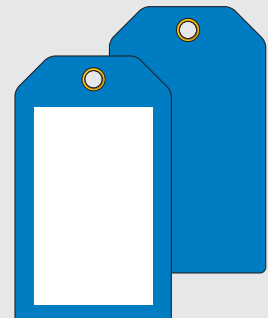

SLM109

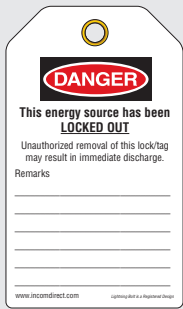

Back print

LOCKOUT (LOTO) Tags

It is the sole responsibility of the user to determine the suitability of this product for their application, including, but not limited to, identifying the risk and its classification. When in doubt consult a qualified professional.

These tags are used to indicate that energy isolating devices are in use and the tagged equipment may not be operated until the Lock Out/Tag Out device is removed. Tags include our patented "LIGHTNING BOLT" for drawing attention to the lockout area. Sold in packages of 25.

HOW TO ORDER:

SELECT TAG - TG6000		SELECT TAG TYPE - PT	ADD TOGETHER. - TG600PT	RL
		PT	RP	RL
		10-mil Poly Tag 3/8" diameter drilled hole.	15-mil Rigid DuraPly 3/8" diameter metal grommet to add strength.	20-mil Rigid Laminated DuraPly 3/8" diameter large grommet for extra strength.





Tags-On-Roll

With Convenient
Dispenser Box
Page 112-113

Safety tags supplied in a roll provide an easy and convenient way to contain and dispense your tags.

TAG ROLL



Bilingual Safety Tags English/Spanish

Use these safety tags as a great way to communicate health and safety issues in a bilingual working environment. We offer a wide variety of stock legends for most applications. We also offer 3 different material types to meet all budgets and durability issues.

It is the sole responsibility of the user to determine the suitability of this product for their application, including, but not limited to, identifying the risk and its classification. When in doubt consult a qualified professional.

We offer 3 different material types to meet all budgets and durability issues. All tags are printed on both sides with state of the art digital printing and come 25 per pack. Don't see the legend you need? Give us a call to see what we can do for your next tag requirement.

HOW TO ORDER:

SELECT TAG - TG7500	SELECT TAG TYPE - PT	ADD TOGETHER. - TG7500PT	RL
	PT	RP	RL
	10-mil Poly Tag 3/8" diameter drilled hole.	15-mil Rigid DuraPly 3/8" diameter metal grommet to add strength.	20-mil Rigid Laminated DuraPly 3/8" diameter large grommet for extra strength.

Bilingual DANGER Tags English/Spanish



Back print

TG7500

TG7501

TG7502



TG7503

TG7504

TG7505

TG7506



Bilingual WARNING Tags English/Spanish



Back print

TG7514

TG7515

TG7516

TG7517

TG7518

TG7519

TG7520

Bilingual CAUTION Tags English/Spanish



Back print

TG7507

TG7508

TG7509



TG7510



TG7511



TG7512



TG7513



Bilingual NOTICE Tags English/Spanish



Back print

TG7521

TG7522

TG7523

TG7524

TG7525

TG7526

TG7527

Bilingual LOCKOUT Tags English/Spanish



Back print

TG7528

TG7529

TG7530

TG7531

TG7532

TG7533

TG7534

Lightning Bolt is a Registered Design of INCOM Manufacturing Group

Bilingual Safety Tags English/French

Use these safety tags as a great way to communicate health and safety issues in a bilingual working environment. We offer a wide variety of stock legends for most applications. We also offer 3 different material types to meet all budgets and durability issues.

It is the sole responsibility of the user to determine the suitability of this product for their application, including, but not limited to, identifying the risk and its classification. When in doubt consult a qualified professional.

We offer 3 different material types to meet all budgets and durability issues. All tags are printed on both sides with state of the art digital printing and come 25 per pack. Don't see the legend you need? Give us a call to see what we can do for your next tag requirement.

HOW TO ORDER:

SELECT TAG - TG7000	SELECT TAG TYPE - PT	ADD TOGETHER. - TG7000PT	RP	RL
	PT		RP	RL
	10-mil Poly Tag 3/8" diameter drilled hole.		15-mil Rigid DuraPly 3/8" diameter metal grommet to add strength.	20-mil Rigid Laminated DuraPly 3/8" diameter large grommet for extra strength.

Bilingual DANGER Tags English/French



Back print

TG7000

TG7001

TG7002



TG7003

TG7004

TG7005

TG7006



Bilingual WARNING Tags English/French



Back print

TG7014

TG7015

TG7016

TG7017

TG7018

TG7019

TG7020

Bilingual CAUTION Tags English/French



Back print

TG7007

TG7008

TG7009



TG7010

TG7011

TG7012

TG7013



Bilingual NOTICE Tags English/French

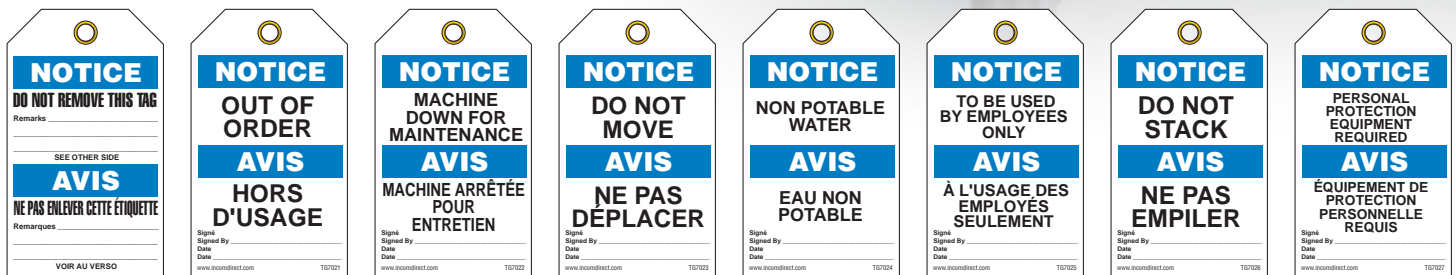

Back print

TG7021

TG7022

TG7023

TG7024

TG7025

TG7026

TG7027

Bilingual LOCKOUT Tags English/French



Back print

TG7028

TG7029

TG7030

TG7031

TG7032

TG7033

TG7034

Lightning Bolt is a Registered Design of INCOM Manufacturing Group

Tags-On-A-Roll

With Convenient Dispenser Box

Safety tags supplied in a roll provide an easy and convenient way to transport and contain your tags, providing a larger tag quantity on hand for heavy demand applications.

Made from 10-mil Polytag stock, these tags are a good choice for indoor or limited use outdoor applications. Stock is waterproof and can be written on with pencil, ball point pen or marker. These tags are 3" x 6.25" with a 0.375" hole and come with 100 or 250 tags per box. These tags are like traditional tags, but connected together by an easy to tear perforation. Just pull the next tag from the dispenser box and tear it off.

The specially designed dispenser box keep the tags safely and neatly contained for any on the go application Perfect for work vehicles, tool cribs, mobile work carts, and many other applications.

Available in a large selection of stock legends, as well a thermal printable versions for a print on demand application. Custom versions also available. Please contact us for details.



Available in rolls of

100 tags
without grommets

250 tags
without grommets

200 tags
with grommets

Inspection Tags

Back print	RT8001	RT8015	RT8022	RT8004	Back print	RT8005	Back print	RT8008

DANGER Tags

Back print	RT1112	RT1000	RT1014	RT1026	RT1087	RT1039	RT1009

HOW TO ORDER:

SELECT TAG - RT1000			SELECT TAG TYPE - C			ADD TOGETHER - RT1000C		
C			F			EG		
100/roll 3/8" diameter drilled hole.			250/roll 3/8" diameter drilled hole.			200/roll 3/8" diameter metal grommet to add strength.		

NOTICE Tags



Back print RT5024 RT5001

WARNING Tags



Back print RT4049 RT4001

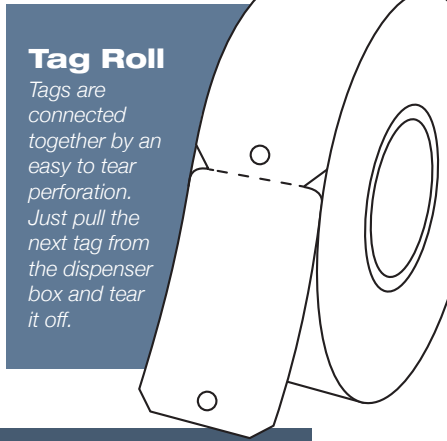

CAUTION Tags



Back print RT3048 RT3001

Lockout Tags



Back print RT6001 RT6002 RT6025 RT6027

Bilingual Tags - English/Spanish



Back print RT7500 RT7502 RT7521 RT7528 RT7530

Bilingual Tags - English/French

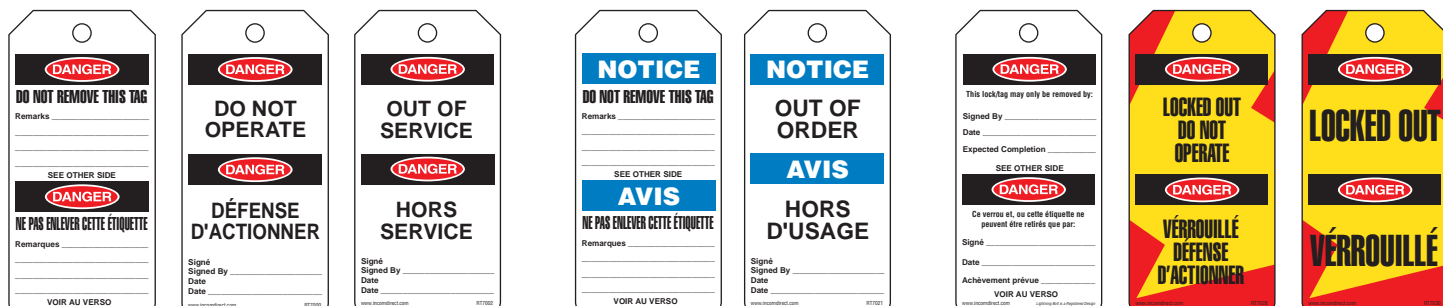

Back print RT7000 RT7002 RT7021 RT7028 RT7030

Inspection Tags

Inspection tags are designed to record and document equipment and machinery inspection, servicing and maintenance events for easy reference.

Tags are made from a durable 15 mil stock and measure 3-3/8" x 5-3/4". Sold in packages of 25 with 3/8" eyelet.



General Tags

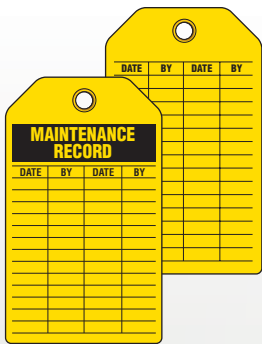

TG8021

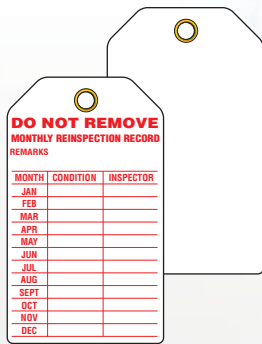

TG8022

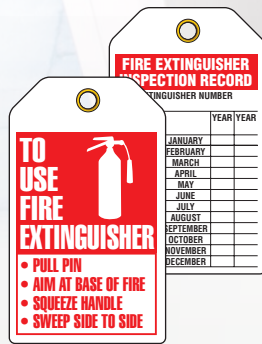

TG8023

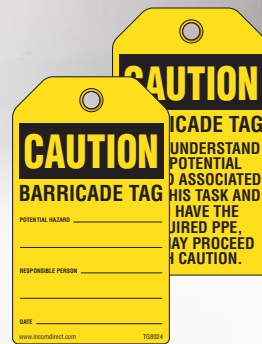

TG8024



TG8025

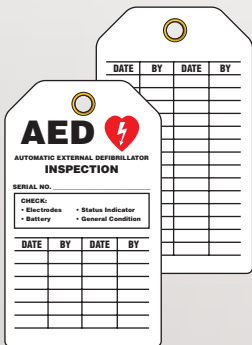

TG8000



TG8001

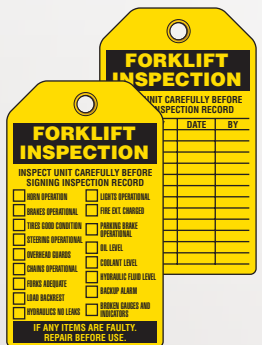

TG8002

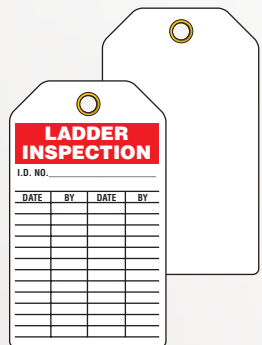

TG8003



TG8004



TG8015

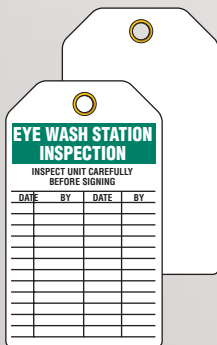

TG8016



TG8017

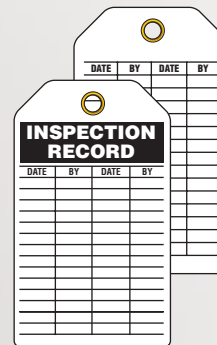

TG8018

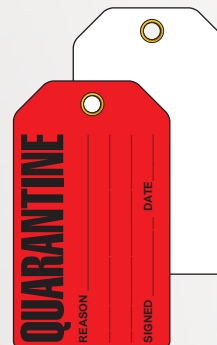

TG8019



TG8020

Scaffold Tags



TG8005



TG8006



TG8007



TG8008



TG8009

Cylinder Tags

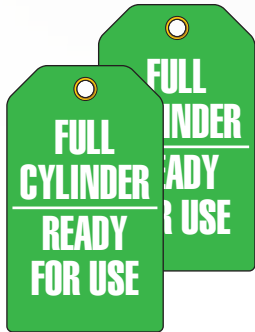

TG8010



TG8011



TG8012



TG8013



TG8014
(Perforated)



Custom Tags

Let us help you design the exact tag you will need for your application. Our tag production capabilities offer a wide range of design, print and finishing options.

What is DOT?

Department of Transportation

Department of Transportation (DOT) is focused on the prevention of incidents when dangerous goods are imported, handled, or offered for transport.

Placards are displayed on vehicles and tanks to identify the risk of products being transported. Shipping labels are essential for packages that contain dangerous goods. All product manufactured to Department of Transportation specifications.



Dangerous Goods Placards

Dangerous goods truck placards are displayed on vehicles and tanks to identify the risk of products being transported. We manufacture our entire placard line to meet Department of Transport (DOT) guidelines and offer them in several material options. Our coated paper tagboard placards offer a cost effective single use; rigid plastic placards offer multiple use even under severe weather conditions; and our adhesive backed VynMark placards are perfect for permanent marking.





**HANDLE
WITH CARE**



Transport Vehicle Markings

We manufacture a wide selection of safety signs & decals, reflectors, and Conspicuity tapes for a variety of fleet marking applications.



Truck Flip Placards and Placard Holders

Our placard holders are manufactured out of high quality aluminum or stainless steel with a stainless steel clip to ensure longevity even in the worst conditions. Our flip charts are printed with DOT legends, and the design is built for durability with a heavy .032" aluminum back plate with baked-on polyester finish to resist fading.



DOT Worded Truck Placards (USA Version)

DOT Truck placards are displayed on vehicles and tanks to identify the risk of products being transported. We manufacture our entire placard line to meet Department of Transport (DOT) guidelines and offer them in several material options. Our paper tagboard placards offer a cost effective single use; rigid plastic placards offer multiple use even under severe weather conditions; and our adhesive backed VynMark placards are perfect for permanent marking. All placards are 10-3/4" x 10-3/4".

Other DOT legends and custom UN numbered placards also available, please call for details. For Canadian TDG version placards please refer to page 128-129.



Adhesive VynMark
 Intended for permanent application on the transport vehicle. They are constructed with an outdoor grade 4-MIL VynMark with an aggressive permanent adhesive backing. Once applied these placards provide a permanent DOT marking solution. 100/pack

Rigid Plastic
 Printed on durable plastic using weather and UV resistant inks. Able to withstand repeated usage under most conditions. Intended for use with placard holders. 100/pack

Tagboard
 Made from a semi-rigid paper card stock with a water resistant coating on both sides. This material is intended for single trip usage, at an economical price. Intended for use with placard holders. 100/pack

<p>CLASS 2</p> <p>Class 2.1</p> <p><i>Flammable Gases</i></p> <p>TA210TB – Tagboard TA210SS – Rigid Plastic TA210PS – Adhesive VynMark</p>	<p>Class 2.2</p> <p><i>Non-Flammable & Non-Toxic Gases</i></p> <p>TA220TB – Tagboard TA220SS – Rigid Plastic TA220PS – Adhesive VynMark</p>	<p>Class 2.3</p> <p><i>Inhalation Hazard</i></p> <p>TA230TB – Tagboard TA230SS – Rigid Plastic TA230PS – Adhesive VynMark</p>	<p>Class 2</p> <p><i>Oxidizing Gases</i></p> <p>TA232TB – Tagboard TA232SS – Rigid Plastic TTA32PS – Adhesive VynMark</p>
--	--	--	--

<p>CLASS 3</p> <p>Class 3</p> <p><i>Flammable Liquids</i></p> <p>TA300TB – Tagboard TA300SS – Rigid Plastic TA300PS – Adhesive VynMark</p>	<p>Class 3</p> <p><i>Combustible Liquids</i></p> <p>TA310TB – Tagboard TA310SS – Rigid Plastic TA310PS – Adhesive VynMark</p>
--	--





<p>CLASS 4</p> <p>Class 4.1</p> <p><i>Flammable Solids</i></p> <p>TA410TB – Tagboard TA410SS – Rigid Plastic TA410PS – Adhesive VynMark</p>	<p>CLASS 4</p> <p>Class 4.2</p> <p><i>Substances Liable to Spontaneous Combustion</i></p> <p>TA420TB – Tagboard TA420SS – Rigid Plastic TA420PS – Adhesive VynMark</p>	<p>CLASS 4</p> <p>Class 4.3</p> <p><i>Water Reactive Substances</i></p> <p>TA430TB – Tagboard TA430SS – Rigid Plastic TA430PS – Adhesive VynMark</p>
---	--	--

<p>CLASS 5</p> <p>Class 5.1</p> <p><i>Oxidizing Substances</i></p> <p>TA510TB – Tagboard TA510SS – Rigid Plastic TA510PS – Adhesive VynMark</p>	<p>CLASS 5</p> <p>Class 5.2</p> <p><i>Organic Peroxides</i></p> <p>TA521TB – Tagboard TA521SS – Rigid Plastic TA521PS – Adhesive VynMark</p>
---	--

<p>CLASS 6</p> <p>Class 6.1</p> <p><i>Poison</i></p> <p>TA600TB – Tagboard TA600SS – Rigid Plastic TA600PS – Adhesive VynMark</p>	<p>CLASS 6</p> <p>Class 6.1</p> <p><i>Inhalation Hazard</i></p> <p>TA620TB – Tagboard TA620SS – Rigid Plastic TA620PS – Adhesive VynMark</p>
---	--

CLASS 7

Class 7

Radioactive Materials

TA700TB – Tagboard
TA700SS – Rigid Plastic
TA700PS – Adhesive VynMark

CLASS 8

Class 8

Corrosives

TA800TB – Tagboard
TA800SS – Rigid Plastic
TA800PS – Adhesive VynMark

CLASS 9

Class 9

Misc. Products, Substances or Organisms

TA960TB – Tagboard
TA960SS – Rigid Plastic
TA960PS – Adhesive VynMark

CLASS 9

Class 9

Danger, Mixed Loads

TA950TB – Tagboard
TA950SS – Rigid Plastic
TA950PS – Adhesive VynMark



ALUMINUM

Aluminum Placard Holder

Page 36-37

Aluminum with a stainless steel clip to ensure longevity even in the worst conditions.

DOT UN Truck Placards (USA Version)

Use these placards when you are required to show a UN number for your Dangerous Goods shipment. Use our individual numbers or numbering kits to produce compliant UN numbered placards in minutes. Check with local compliance authorities to determine appropriate product for your application. For Canadian TDG versions, please see page 130-131.

Adhesive VynMark

Intended for permanent application on the transport vehicle. They are constructed with an outdoor grade 4-MIL VynMark with an aggressive permanent adhesive backing. Once applied these placards provide a permanent DOT marking solution. 100/pack

Rigid Plastic

Printed on durable plastic using weather and UV resistant inks. Able to withstand repeated usage under most conditions. Intended for use with placard holders. 100/pack

Tagboard

Made from a semi-rigid paper card stock with a water resistant coating on both sides. This material is intended for single trip usage, at an economical price. Intended for use with placard holders. 100/pack

CLASS 2

Flammable Gases TT210TBPIN – Tagboard TT210SSPIN – Rigid Plastic TT210PSPIN – Adhesive VynMark	Non-Flammable & Non-Toxic Gases TT220TBPIN – Tagboard TT220SSPIN – Rigid Plastic TT220PSPIN – Adhesive VynMark	Inhalation Hazard TA230TBPIN – Tagboard TA230SSPIN – Rigid Plastic TA230PSPIN – Adhesive VynMark	Oxidizing Gases TT232TBPIN – Tagboard TT232SSPIN – Rigid Plastic TT232PSPIN – Adhesive VynMark

CLASS 3

Flammable Liquids TT300TBPIN – Tagboard TT300SSPIN – Rigid Plastic TT300PSPIN – Adhesive VynMark	Combustible Liquids TA310TBPIN – Tagboard TA310SSPIN – Rigid Plastic TA310PSPIN – Adhesive VynMark

CLASS 5

Oxidizing Substances TT510TBPIN – Tagboard TT510SSPIN – Rigid Plastic TT510PSPIN – Adhesive VynMark	Organic Peroxides TT521TBPIN – Tagboard TT521SSPIN – Rigid Plastic TT521PSPIN – Adhesive VynMark

Placard Numbers & Number Kits

For use with blank PIN box placards, 3.5" - high numbers are printed in black on clear or white with permanent adhesive backing. Outer dimensions are 2.125" W x 4" L. Each kit includes 50 decals of each number from 0 to 9 (500 decals). Individual numbers available separately in packages of 50 numbers each. All numbers have an over-lamination for added durability.

Description	Black on Clear	Black on White
Complete Kit	UNCLKIT	UNWHKIT
'0'	UNCL0	UNWH0
'1'	UNCL1	UNWH1
'2'	UNCL2	UNWH2
'3'	UNCL3	UNWH3
'4'	UNCL4	UNWH4
'5'	UNCL5	UNWH5
'6'	UNCL6	UNWH6
'7'	UNCL7	UNWH7
'8'	UNCL8	UNWH8
'9'	UNCL9	UNWH9



CLASS 4

Flammable Solids	Substances Liable to Spontaneous Combustion	Water Reactive Substances
TT410TBPIN – Tagboard TT410SSPIN – Rigid Plastic TT410PSPIN – Adhesive VynMark	TT420TBPIN – Tagboard TT420SSPIN – Rigid Plastic TT420PSPIN – Adhesive VynMark	TT430TBPIN – Tagboard TT430SSPIN – Rigid Plastic TT430PSPIN – Adhesive VynMark

CLASS 6

Poison	Inhalation Hazard
TT600TBPIN – Tagboard TT600SSPIN – Rigid Plastic TT600PSPIN – Adhesive VynMark	TA620TBPIN – Tagboard TA620SSPIN – Rigid Plastic TA620PSPIN – Adhesive VynMark

CLASS 8

Corrosives
TA800TBPIN – Tagboard TA800SSPIN – Rigid Plastic TA800PSPIN – Adhesive VynMark

CLASS 9

Misc. Products, Substances or Organisms
TA960TBPIN – Tagboard TA960SSPIN – Rigid Plastic TA960PSPIN – Adhesive VynMark



DOT Pre-Numbered Truck Placards

(USA Version)

We stock a large selection of pre-printed UN numbered placards for your specific transportation compliance needs.

Choose from any of our stock legends below or call for pricing on a custom UN numbered placard. Available in paper tagboard, rigid plastic or adhesive VynMark to suit your specific application. Check with local compliance authorities to determine appropriate product for your application. For Canadian version, please refer to page 132-133.

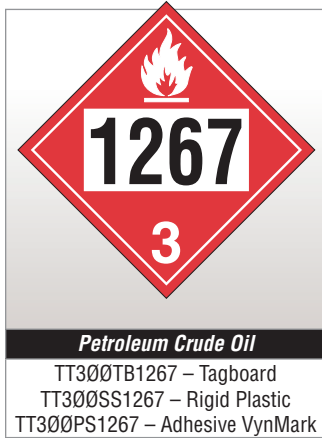
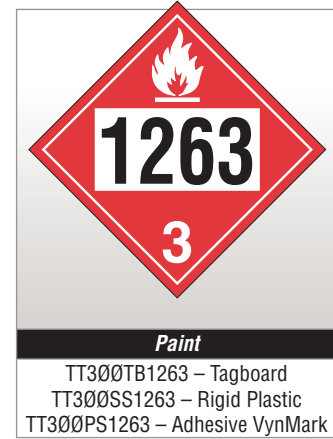
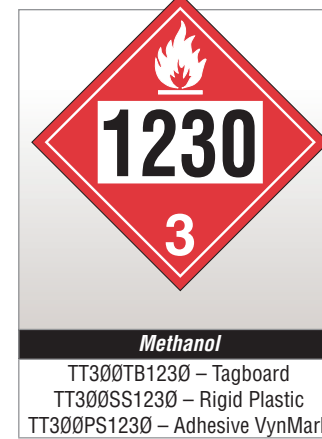
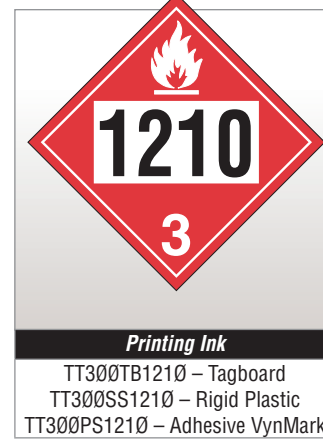
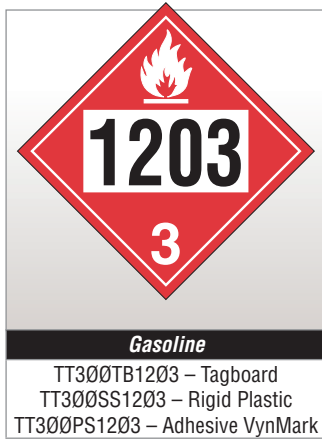
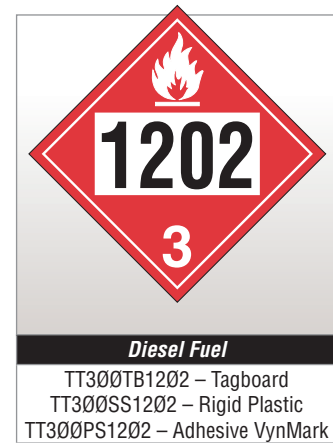
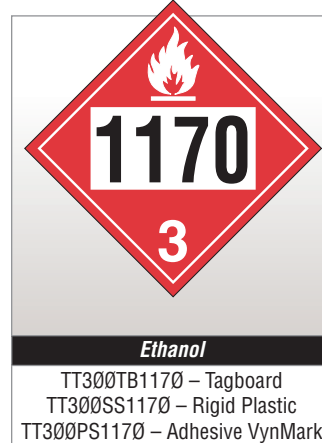
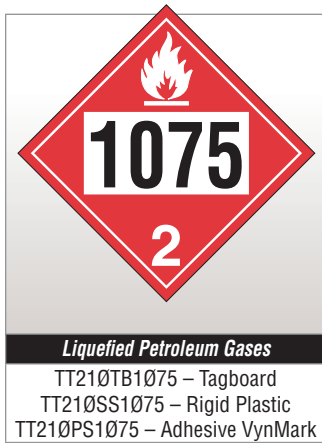
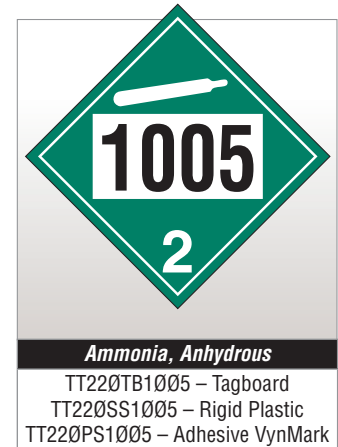
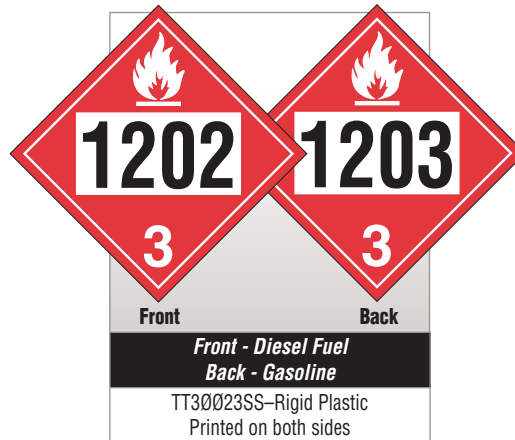

1993
3

Flammable Liquid, N.O.S.
TT300TB1993 – Tagboard
TT300SS1993 – Rigid Plastic
TT300PS1993 – Adhesive VynMark

2924
3

Flammable Liquid, Corrosive, N.O.S.
TT300TB2924 – Tagboard
TT300SS2924 – Rigid Plastic
TT300PS2924 – Adhesive VynMark

3256
3

Elevated Temperature Liquid, Flammable N.O.S.
TT300TB3256 – Tagboard
TT300SS3256 – Rigid Plastic
TT300PS3256 – Adhesive VynMark

3475
3

Ethanol And Gasoline Mixture
TT300TB3475 – Tagboard
TT300SS3475 – Rigid Plastic
TT300PS3475 – Adhesive VynMark

3494
3

Petroleum Sour Crude Oil, Flammable, Toxic
TT300TB3494 – Tagboard
TT300SS3494 – Rigid Plastic
TT300PS3494 – Adhesive VynMark

1942
5.1

Ammonium Nitrite
TT510TB1942 – Tagboard
TT510SS1942 – Rigid Plastic
TT510PS1942 – Adhesive VynMark

1719
8

Caustic Alkali Liquid, N.O.S.
TA800TB1719 – Tagboard
TA800SS1719 – Rigid Plastic
TA800PS1719 – Adhesive VynMark

1760
8

Corrosive Liquid N.O.S.
TA800TB1760 – Tagboard
TA800SS1760 – Rigid Plastic
TA800PS1760 – Adhesive VynMark

1789
8

Hydrochloric Acid
TA800TB1789 – Tagboard
TA800SS1789 – Rigid Plastic
TA800PS1789 – Adhesive VynMark

1824
8

Sodium Hydroxide Solution
TA800TB1824 – Tagboard
TA800SS1824 – Rigid Plastic
TA800PS1824 – Adhesive VynMark

2794
8

Batteries, Wet, Filled With Acid
TA800TB2794 – Tagboard
TA800SS2794 – Rigid Plastic
TA800PS2794 – Adhesive VynMark

3264
8

Corrosive Liquid, Acidic, Inorganic, N.O.S.
TA800TB3264 – Tagboard
TA800SS3264 – Rigid Plastic
TA800PS3264 – Adhesive VynMark

3265
8

Corrosive Liquid, Acidic, Organic, N.O.S.
TA800TB3265 – Tagboard
TA800SS3265 – Rigid Plastic
TA800PS3265 – Adhesive VynMark

3266
8

Corrosive Liquid, Basic, Inorganic, N.O.S.
TA800TB3266 – Tagboard
TA800SS3266 – Rigid Plastic
TA800PS3266 – Adhesive VynMark

3077
9

Environmentally Hazardous Substance, Solid, N.O.S.
TA960TB3077 – Tagboard
TA960SS3077 – Rigid Plastic
TA960PS3077 – Adhesive VynMark

3082
9

Environmentally Hazardous Substance, Liquid, N.O.S.
TA960TB3082 – Tagboard
TA960SS3082 – Rigid Plastic
TA960PS3082 – Adhesive VynMark

DOT Worded Shipping Labels

(USA Version)

Shipping Labels are essential for packages that contain dangerous goods. Labels are available in two materials, adhesive paper for indoor applications and adhesive VynMark for extended outdoor usage.

Our Shipping Labels are manufactured to DOT specifications with fade resistant inks. Labels are 4"x 4" and sold 500/roll.



Empty
TA400P - Adhesive Paper
TA400V - Adhesive VynMark



Cargo Aircraft Only
TA401P - Adhesive Paper
TA401V - Adhesive VynMark



CLASS 2.1
Flammable Gases
TA21P - Adhesive Paper
TA21V - Adhesive VynMark



CLASS 2.2
Class 2 - Non-Flammable & Non-Toxic Gases
TA22P - Adhesive Paper
TA22V - Adhesive VynMark



CLASS 2.3
Inhalation Hazard
TA23P - Adhesive Paper
TA23V - Adhesive VynMark



CLASS 3
Flammable Liquids
TA30P - Adhesive Paper
TA30V - Adhesive VynMark



CLASS 4.1
Flammable Solids
TA41P - Adhesive Paper
TA41V - Adhesive VynMark



CLASS 4.2
Spontaneous Combustion
TA42P - Adhesive Paper
TA42V - Adhesive VynMark



CLASS 4.3
Water Reactive Substances
TA43P - Adhesive Paper
TA43V - Adhesive VynMark



CLASS 5.1
Oxidizing Substances
TA51P - Adhesive Paper
TA51V - Adhesive VynMark



CLASS 5.2
Organic Peroxides
TA53P - Adhesive Paper
TA53V - Adhesive VynMark



CLASS 6.1
Inhalation Hazard
TA60P - Adhesive Paper
TA60V - Adhesive VynMark



CLASS 6.1
Poison
TA61P - Adhesive Paper
TA61V - Adhesive VynMark



CLASS 6.2
Infectious Substances
TA63P - Adhesive Paper
TA63V - Adhesive VynMark



CLASS 7 Cat. 1
Radioactive Materials Cat. 1
TA71P - Adhesive Paper
TA71V - Adhesive VynMark



CLASS 7 Cat. 2
Radioactive Materials Cat. 2
TA72P - Adhesive Paper
TA72V - Adhesive VynMark



CLASS 7 Cat. 3
Radioactive Materials Cat. 3
TA73P - Adhesive Paper
TA73V - Adhesive VynMark



CLASS 8
Corrosives
TA80P - Adhesive Paper
TA80V - Adhesive VynMark



CLASS 9
Miscellaneous Products
TA91P - Adhesive Paper
TA91V - Adhesive VynMark



What is TDG?

Transportation of Dangerous Goods

Transportation of Dangerous Goods (TDG) is focused on the prevention of incidents when dangerous goods are imported, handled, or offered for transport.

Placards are displayed on vehicles and tanks to identify the risk of products being transported. Shipping labels are essential for packages that contain dangerous goods. All product manufactured to Transport Canada specifications.



Dangerous Goods Placards

Placards are displayed on vehicles and tanks to identify the risk of products being transported. We manufacture our entire placard line to meet Transport Canada guidelines and offer them in your choice of material. Our coated paper tagboard placards offer a cost effective single use; rigid plastic placards offer multiple use even under severe weather conditions; and our adhesive VynMark is perfect for permanent marking.





**HANDLE
WITH CARE**



Transport Vehicle Markings

We manufacture a wide selection of safety signs & decals, reflectors, and Conspicuity tapes for a variety of fleet marking applications.



Truck Flip Placards and Placard Holders

Our placard holders are manufactured out of high quality aluminum or stainless steel with a stainless steel clip to ensure longevity even in the worst conditions. Our flip charts are printed with Canadian TDG legends, and the design is built for durability with a heavy .031" aluminum back plate with baked-on polyester finish to resist fading.



TDG Truck Placards (Canada & International)

Placards are displayed on vehicles and tanks to identify the risk of products being transported. We manufacture our entire placard line to meet Transport Canada guidelines and offer them in your choice of material. Check with local compliance authorities to determine correct product for your application. All placards are 10-3/4" x 10-3/4".

Adhesive VynMark

Intended for permanent application on the transport vehicle. They are constructed with an outdoor grade 4-MIL VynMark with an aggressive permanent adhesive backing. Once applied these placards provide a permanent TDG marking solution. 100/pack

Rigid Plastic

Manufactured on durable plastic able to withstand repeated usage under any weather conditions. The ink is applied using a silk screen process to ensure print quality and resist fading. Intended for use with placard holders. 100/pack

Tagboard

Made from a semi-rigid paper card stock with a water resistant coating on both sides. This material is intended for single trip usage, at an economical price. Intended for use with placard holders. 100/pack

CLASS 1

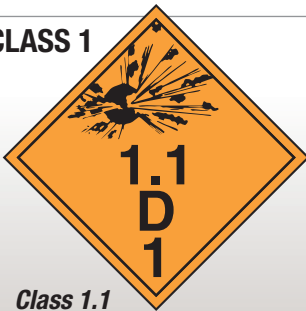

Class 1.1

Explosives

TT110DTB – Tagboard
TT110DSS – Rigid Plastic
TT110DPS – Adhesive VynMark

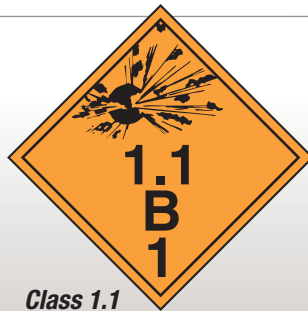

Class 1.1

Explosives

TT110BTB – Tagboard
TT110BSS – Rigid Plastic
TT110BPS – Adhesive VynMark

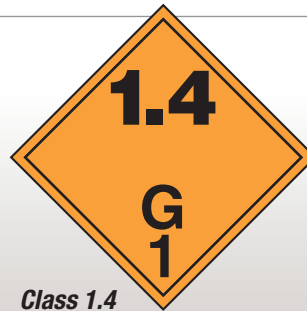

Class 1.4

Explosives

TT140GTB – Tagboard
TT140GSS – Rigid Plastic
TT140GPS – Adhesive VynMark

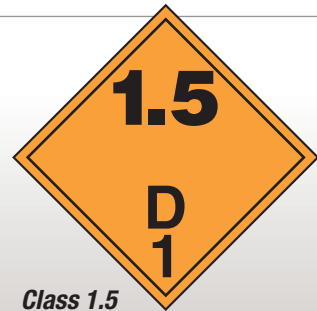

Class 1.5

Explosives

TT150DTB – Tagboard
TT150DSS – Rigid Plastic
TT150DPS – Adhesive VynMark

CLASS 2

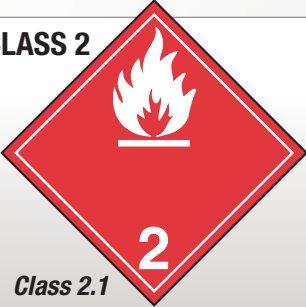

Class 2.1

Flammable Gases

TT210TB – Tagboard
TT210SS – Rigid Plastic
TT210PS – Adhesive VynMark



Class 2.2

Non-Flammable & Non-Toxic Gases

TT220TB – Tagboard
TT220SS – Rigid Plastic
TT220PS – Adhesive VynMark

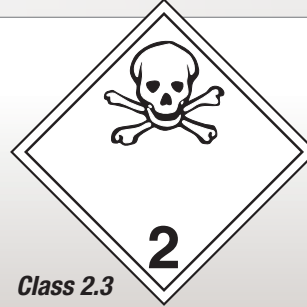

Class 2.3

Toxic Gases

TT230TB – Tagboard
TT230SS – Rigid Plastic
TT230PS – Adhesive VynMark



Class 2

Oxidizing Gases

TT232TB – Tagboard
TT232SS – Rigid Plastic
TT232PS – Adhesive VynMark

CLASS 3



Class 3

Flammable Liquids

TT300TB – Tagboard
TT300SS – Rigid Plastic
TT300PS – Adhesive VynMark

CLASS 4

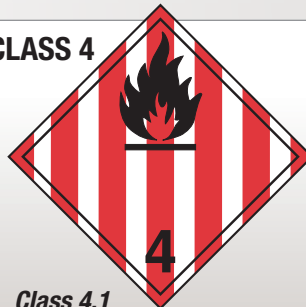

Class 4.1

Flammable Solids

TT410TB – Tagboard
TT410SS – Rigid Plastic
TT410PS – Adhesive VynMark



Class 4.2

Substances Liable to Spontaneous Combustion

TT420TB – Tagboard
TT420SS – Rigid Plastic
TT420PS – Adhesive VynMark



Class 4.3

Water Reactive Substances

TT430TB – Tagboard
TT430SS – Rigid Plastic
TT430PS – Adhesive VynMark

CLASS 5

Class 5.1

Oxidizing Substances
 TT510TB – Tagboard
 TT510SS – Rigid Plastic
 TT510PS – Adhesive VynMark

Class 5.2

Organic Peroxides
 TT521TB – Tagboard
 TT521SS – Rigid Plastic
 TT521PS – Adhesive VynMark

CLASS 6

Class 6.1

Toxic Substances
 TT600TB – Tagboard
 TT600SS – Rigid Plastic
 TT600PS – Adhesive VynMark

Class 6.2

Infectious Substances
 TT620TB – Tagboard
 TT620SS – Rigid Plastic
 TT620PS – Adhesive VynMark

CLASS 7

Class 7

Radioactive Materials
 TT700TB – Tagboard
 TT700SS – Rigid Plastic
 TT700PS – Adhesive VynMark

CLASS 8

Class 8

Corrosives
 TT800TB – Tagboard
 TT800SS – Rigid Plastic
 TT800PS – Adhesive VynMark

CLASS 9

Class 9

Misc. Products, Substances or Organisms
 TT960TB – Tagboard
 TT960SS – Rigid Plastic
 TT960PS – Adhesive VynMark

DANGER, Mixed Loads
 TT950TB – Tagboard
 TT950SS – Rigid Plastic
 TT950PS – Adhesive VynMark

Marine Pollutant
 TT166TB – Tagboard
 TT166SS – Rigid Plastic
 TT166PS – Adhesive VynMark

Dangerous Goods
 TT980TB – Tagboard
 TT980SS – Rigid Plastic
 TT980PS – Adhesive VynMark

Toxic Inhalation Hazard
 TT940SS – Rigid Plastic
 TT940PS – Adhesive VynMark

Inhalation Hazard
 TT941SS – Rigid Plastic
 TT941PS – Adhesive VynMark



ALUMINUM

Aluminum Placard Holder

Page 136-137

Aluminum with a stainless steel clip to ensure longevity even in the worst conditions.

TDG UN Truck Placards (Canada & International)

Use these placards when you are required to show a UN number for your Dangerous Goods shipment. Use our individual numbers or numbering kits to produce compliant UN numbered placards in minutes. Check with local compliance authorities to determine appropriate product for your application. All placards are 10-3/4" x 10-3/4".

Adhesive VynMark

Intended for permanent application on the transport vehicle. They are constructed with an outdoor grade 4-MIL VynMark with an aggressive permanent adhesive backing. Once applied these placards provide a permanent TDG marking solution. 100/pack

Rigid Plastic

Manufactured on durable plastic able to withstand repeated usage under any weather conditions. The ink is applied using a silk screen process to ensure print quality and resist fading. Intended for use with placard holders. 100/pack

Tagboard

Made from a semi-rigid paper card stock with a water resistant coating on both sides. This material is intended for single trip usage, at an economical price. Intended for use with placard holders. 100/pack

CLASS 2

Flammable Gases	Non-Flammable & Non-Toxic Gases	Toxic Gases	Oxidizing Gases
TT210TBPIN – Tagboard TT210SSPIN – Rigid Plastic TT210PSPIN – Adhesive VynMark	TT220TBPIN – Tagboard TT220SSPIN – Rigid Plastic TT220PSPIN – Adhesive VynMark	TT230TBPIN – Tagboard TT230SSPIN – Rigid Plastic TT230PSPIN – Adhesive VynMark	TT232TBPIN – Tagboard TT232SSPIN – Rigid Plastic TT232PSPIN – Adhesive VynMark

CLASS 3

CLASS 4

Flammable Liquids	Flammable Solids	Substances Liable to Spontaneous Combustion	Water Reactive Substances
TT300TBPIN – Tagboard TT300SSPIN – Rigid Plastic TT300PSPIN – Adhesive VynMark	TT410TBPIN – Tagboard TT410SSPIN – Rigid Plastic TT410PSPIN – Adhesive VynMark	TT420TBPIN – Tagboard TT420SSPIN – Rigid Plastic TT420PSPIN – Adhesive VynMark	TT430TBPIN – Tagboard TT430SSPIN – Rigid Plastic TT430PSPIN – Adhesive VynMark

Placard Numbers & Number Kits

For use with blank PIN box placards, 3.5" - high numbers are printed in black on clear or white with permanent adhesive backing. Outer dimensions are 2.125" W x 4" L. Each kit includes 50 decals of each number from 0 to 9 (500 decals). Individual numbers available separately in packages of 50 numbers each. All numbers have an over-lamination for added durability.

Description	Black on Clear	Black on White
Complete Kit	UNCLKIT	UNWHKIT
'0'	UNCL0	UNWH0
'1'	UNCL1	UNWH1
'2'	UNCL2	UNWH2
'3'	UNCL3	UNWH3
'4'	UNCL4	UNWH4
'5'	UNCL5	UNWH5
'6'	UNCL6	UNWH6
'7'	UNCL7	UNWH7
'8'	UNCL8	UNWH8
'9'	UNCL9	UNWH9



CLASS 5

Oxidizing Substances	Organic Peroxides
TT510TBPIN – Tagboard TT510SSPIN – Rigid Plastic TT510PSPIN – Adhesive VynMark	TT521TBPIN – Tagboard TT521SSPIN – Rigid Plastic TT521PSPIN – Adhesive VynMark

CLASS 6

Toxic Substances	Infectious Substances
TT600TBPIN – Tagboard TT600SSPIN – Rigid Plastic TT600PSPIN – Adhesive VynMark	TT620TBPIN – Tagboard TT620SSPIN – Rigid Plastic TT620PSPIN – Adhesive VynMark

CLASS 7

Radioactive Materials

TT700TBPIN – Tagboard
 TT700SSPIN – Rigid Plastic
 TT700PSPIN – Adhesive VynMark

CLASS 8

Corrosives

TT800TBPIN – Tagboard
 TT800SSPIN – Rigid Plastic
 TT800PSPIN – Adhesive VynMark

CLASS 9

Misc. Products, Substances or Organisms

TT960TBPIN – Tagboard
 TT960SSPIN – Rigid Plastic
 TT960PSPIN – Adhesive VynMark



TDG Pre-Numbered Truck Placards

(Canada & International)

We stock a large selection of pre-printed UN numbered placards for your specific transportation compliance needs.

Choose from any of our stock legends below or call for pricing on a custom UN numbered placard. Available in paper tagboard, rigid plastic or adhesive VynMark to suit your specific application. Check with local compliance authorities to determine appropriate product for your application. All placards are 10-3/4" x 10-3/4".

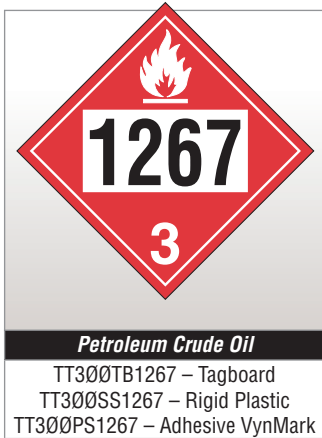
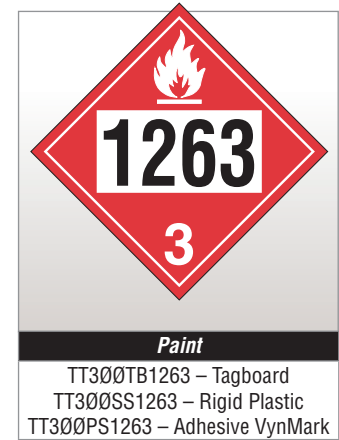
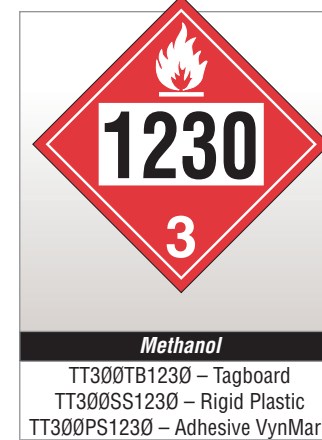
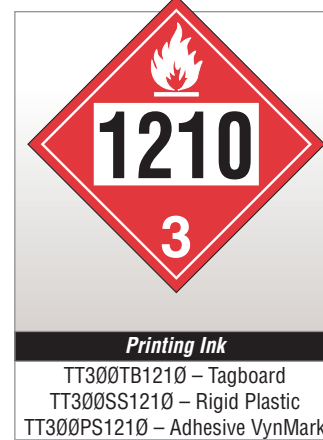
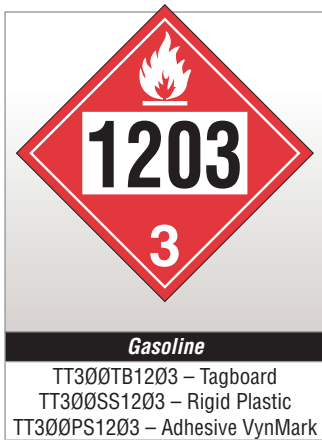
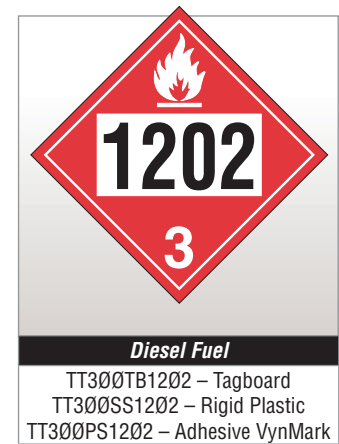
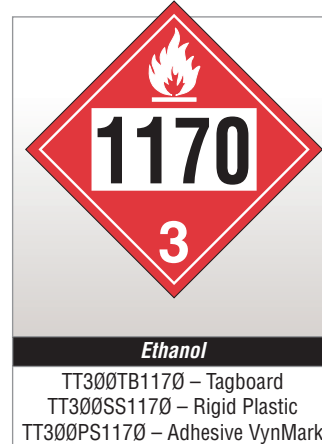
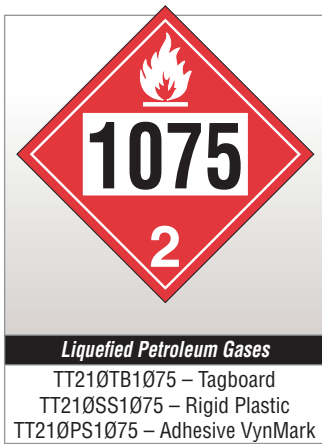
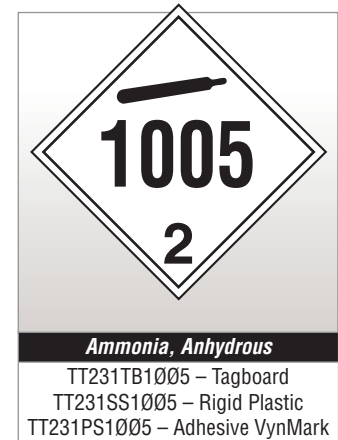
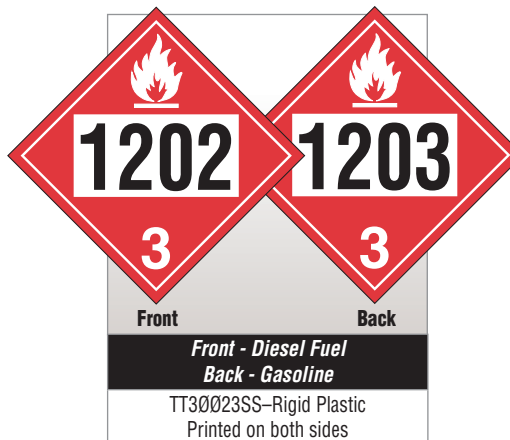

1993
3

Flammable Liquid, N.O.S.
TT300TB1993 – Tagboard
TT300SS1993 – Rigid Plastic
TT300PS1993 – Adhesive VynMark

2924
3

Flammable Liquid, Corrosive, N.O.S.
TT300TB2924 – Tagboard
TT300SS2924 – Rigid Plastic
TT300PS2924 – Adhesive VynMark

3256
3

Elevated Temperature Liquid, Flammable N.O.S.
TT300TB3256 – Tagboard
TT300SS3256 – Rigid Plastic
TT300PS3256 – Adhesive VynMark

3475
3

Ethanol And Gasoline Mixture
TT300TB3475 – Tagboard
TT300SS3475 – Rigid Plastic
TT300PS3475 – Adhesive VynMark

3494
3

Petroleum Sour Crude Oil, Flammable, Toxic
TT300TB3494 – Tagboard
TT300SS3494 – Rigid Plastic
TT300PS3494 – Adhesive VynMark

1942
5.1

Ammonium Nitrite
TT510TB1942 – Tagboard
TT510SS1942 – Rigid Plastic
TT510PS1942 – Adhesive VynMark

1719
8

Caustic Alkali Liquid, N.O.S.
TT800TB1719 – Tagboard
TT800SS1719 – Rigid Plastic
TT800PS1719 – Adhesive VynMark

1760
8

Corrosive Liquid N.O.S.
TT800TB1760 – Tagboard
TT800SS1760 – Rigid Plastic
TT800PS1760 – Adhesive VynMark

1789
8

Hydrochloric Acid
TT800TB1789 – Tagboard
TT800SS1789 – Rigid Plastic
TT800PS1789 – Adhesive VynMark

1824
8

Sodium Hydroxide Solution
TT800TB1824 – Tagboard
TT800SS1824 – Rigid Plastic
TT800PS1824 – Adhesive VynMark

2794
8

Batteries, Wet, Filled With Acid
TT800TB2794 – Tagboard
TT800SS2794 – Rigid Plastic
TT800PS2794 – Adhesive VynMark

3264
8

Corrosive Liquid, Acidic, Inorganic, N.O.S.
TT800TB3264 – Tagboard
TT800SS3264 – Rigid Plastic
TT800PS3264 – Adhesive VynMark

3265
8

Corrosive Liquid, Acidic, Organic, N.O.S.
TT800TB3265 – Tagboard
TT800SS3265 – Rigid Plastic
TT800PS3265 – Adhesive VynMark

3266
8

Corrosive Liquid, Basic, Inorganic, N.O.S.
TT800TB3266 – Tagboard
TT800SS3266 – Rigid Plastic
TT800PS3266 – Adhesive VynMark

3077
9

Environmentally Hazardous Substance, Solid, N.O.S.
TT960TB3077 – Tagboard
TT960SS3077 – Rigid Plastic
TT960PS3077 – Adhesive VynMark

3082
9

Environmentally Hazardous Substance, Liquid, N.O.S.
TT960TB3082 – Tagboard
TT960SS3082 – Rigid Plastic
TT960PS3082 – Adhesive VynMark

TDG Shipping Labels

(Canada & International)

Shipping Labels are essential for packages that contain dangerous goods. Labels are available in two materials, adhesive paper for indoor applications and adhesive VynMark for extended outdoor usage.

Our Shipping Labels are manufactured to Transport Canada specifications with fade resistant inks. Labels are 4"x 4" and sold 500/roll.



LIMITED QUANTITY "Y"
Dangerous Goods
TT97P - Adhesive Paper
TT97V - Adhesive VynMark



LIMITED QUANTITY
Dangerous Goods
TT98P - Adhesive Paper
TT98V - Adhesive VynMark



ENVIRONMENTALLY HAZARDOUS
Marine Pollutant
TT74P - Adhesive Paper
TT74V - Adhesive VynMark



CLASS 2.1
Flammable Gases
TT21P - Adhesive Paper
TT21V - Adhesive VynMark



CLASS 2.2
Class 2 - Non-Flammable & Non-Toxic Gases
TT22P - Adhesive Paper
TT22V - Adhesive VynMark



CLASS 2.3
Toxic Gases
TT23P - Adhesive Paper
TT23V - Adhesive VynMark



CLASS 2
Oxidizing Gases
TT50P - Adhesive Paper
TT50V - Adhesive VynMark



CLASS 3
Flammable Liquids
TT30P - Adhesive Paper
TT30V - Adhesive VynMark



CLASS 4.1
Flammable Solids
TT41P - Adhesive Paper
TT41V - Adhesive VynMark



CLASS 4.2
Spontaneous Combustion
TT42P - Adhesive Paper
TT42V - Adhesive VynMark



CLASS 4.3
Water Reactive Substances
TT43P - Adhesive Paper
TT43V - Adhesive VynMark



CLASS 5.1
Oxidizing Substances
TT51P - Adhesive Paper
TT51V - Adhesive VynMark



CLASS 5.2
Organic Peroxides
TT53P - Adhesive Paper
TT53V - Adhesive VynMark



CLASS 6.1
Toxic Substances
TT60P - Adhesive Paper
TT60V - Adhesive VynMark



CLASS 6.2
Infectious Substances
TT63P - Adhesive Paper
TT63V - Adhesive VynMark



CLASS 7 Cat. 1
Radioactive Materials Cat. 1
TT71P - Adhesive Paper
TT71V - Adhesive VynMark



CLASS 7 Cat. 2
Radioactive Materials Cat. 2
TT72P - Adhesive Paper
TT72V - Adhesive VynMark



CLASS 7 Cat. 3
Radioactive Materials Cat. 3
TT73P - Adhesive Paper
TT73V - Adhesive VynMark



CLASS 8
Corrosives
TT80P - Adhesive Paper
TT80V - Adhesive VynMark



CLASS 9
Misc. Products
TT91P - Adhesive Paper
TT91V - Adhesive VynMark



CLASS 9
Lithium Battery
TT92P - Adhesive Paper
TT92V - Adhesive VynMark



Placard Holder

Our placard holders are manufactured out of high quality aluminum or stainless steel with a stainless steel clip to ensure longevity even in the worst conditions. Placard holders have 10 pre-drilled mounting holes for ease of installation. Holder has a formed ramp at the clip to guide placards easily over the clip during removal. Back plate has several raised bumps that keep plastic placards from becoming stuck in the holder during winter weather.

Placard holder is available in natural aluminum (PH223) Or for ultimate durability, longevity and chemical resistance, try our stainless steel version (PH226).

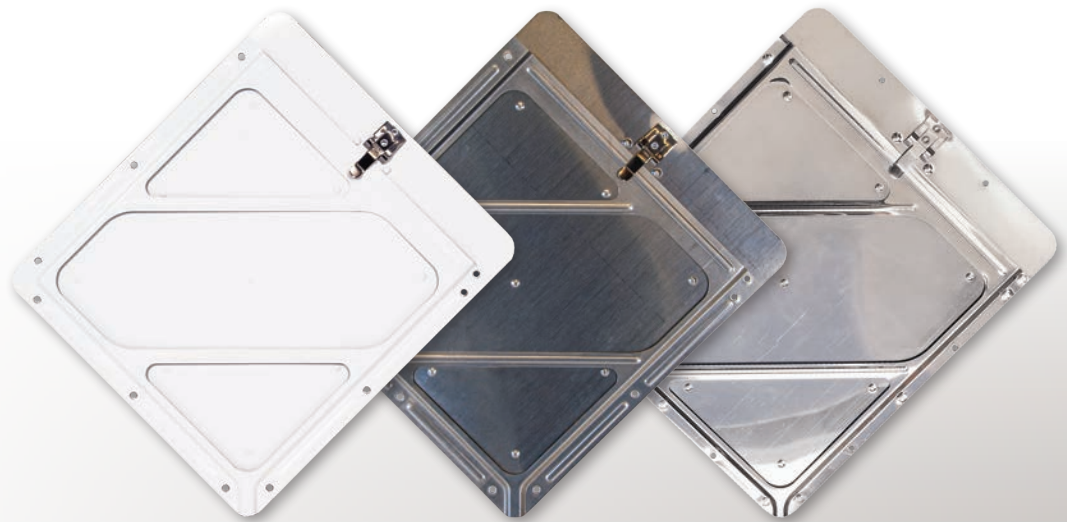

PH223W
(Painted White)

PH223
(Natural Aluminum)

PH226
(Stainless Steel)

Easy Access Aluminum Placard Holder With Shield

These highly durable placard holders are ideal for extreme weather or muddy conditions because they come with a removable protective shield to cover the placard while in use. This style of placard holder is typically considered the easiest to use in severe conditions.

Replacement shields (PH221) and clips (FCCLIP) also available.

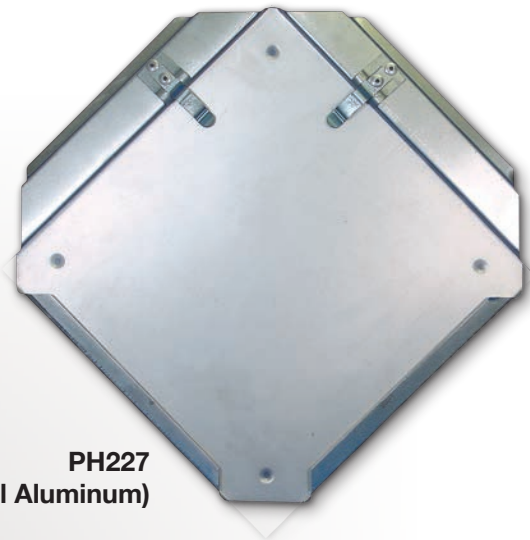

PH227
(Natural Aluminum)

Heavy Duty Placard Holder

Our Heavy Duty Placard holders are manufactured out of 0.040" thick pre-painted white aluminum with a stainless steel clip to ensure longevity even in the worst conditions. These holders have 14 pre-drilled mounting holes for installation. The Heavy Duty holder has a four clip design for added grip on your TDG placards. When used in combination with our PH221 clear shield, it will provide a highly durable, and easy to use placard holding system.

Sized at 14.5" x 14.5", this holder can also be used on most roll up style doors.

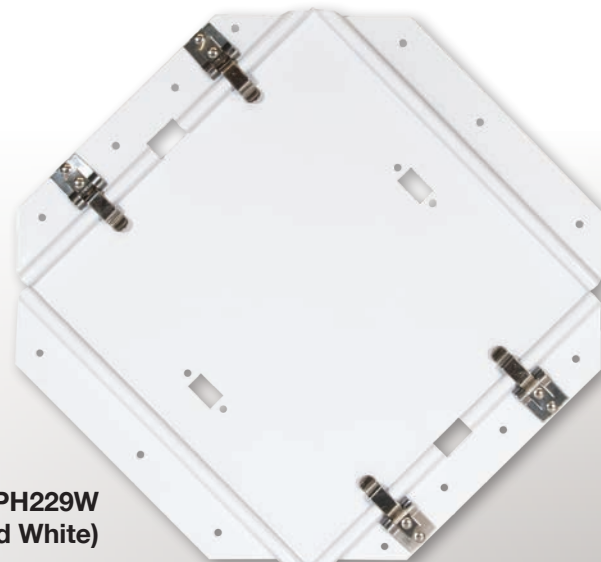

PH229W
(Painted White)

Split Placard Holder

Our Split Placard Holders use our standard model (PH223/PH223W) and are split down the middle of the holder allowing for roll up door applications. Manufactured out of high quality aluminum and a stainless steel clip to ensure longevity even in the worst conditions. Placard holders have 10 pre-drilled mounting holes for ease of installation. Holder has a formed ramp at the clip to guide placards easily over the clip during removal. Back plate has several raised bumps that keep plastic placards from becoming stuck in the holder during winter weather.

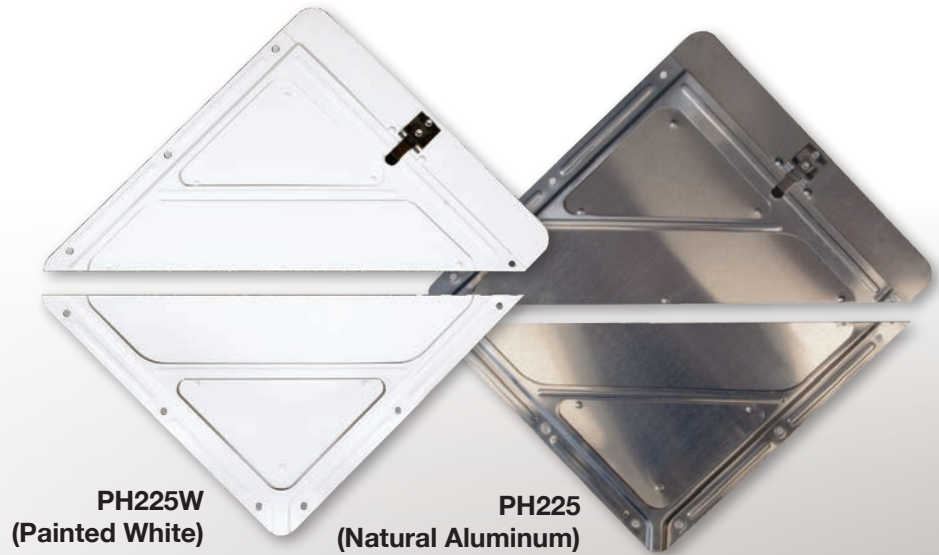

PH225W
(Painted White)

PH225
(Natural Aluminum)

Clipped Corner Placard Holder

These placard holders are the same design as our PH223 series, but have the corners "clipped" for use on roll up doors. Measuring 14.875" across from clipped corner to clipped corner. Manufactured out of high quality aluminum with a stainless steel clip to ensure longevity even in the worst conditions, these placard holders have 10 pre-drilled mounting holes for ease of installation. Holder has a formed ramp at the clip to guide placards easily over the clip during removal. Back plate has several raised bumps that keep plastic placards from becoming stuck in the holder during winter weather.

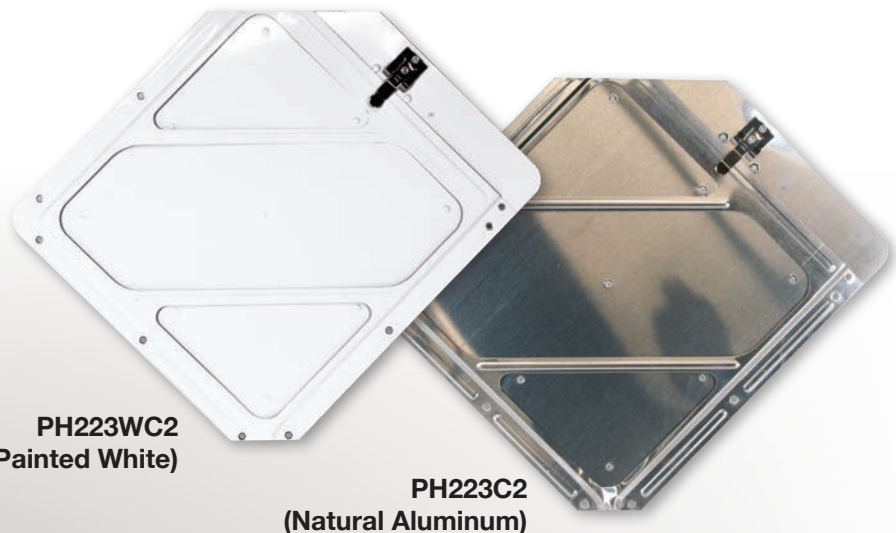

PH223WC2
(Painted White)

PH223C2
(Natural Aluminum)

Placard Holder Face Plates

For an economical solution, try the face plate only version of our holders. Simply mount them directly on the trailer, add a stainless steel clip (PHCLIP) in the appropriate space, and save. This face plate holder is available in natural aluminum (PH230).

PH230
(Natural Aluminum)

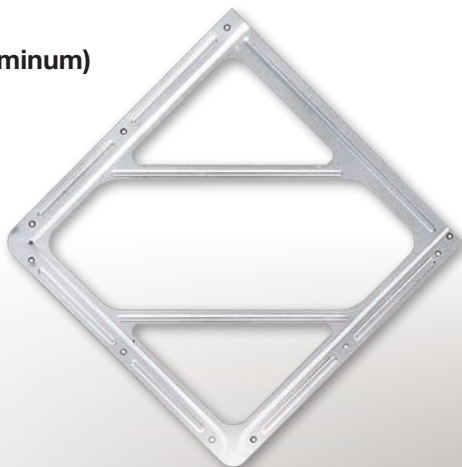

Protective Shield

Our clear placard shields are made from durable 0.040" clear polyethylene PETG plastic. These shields will protect the surface of the placard from abrasion, and will ensure tagboard style placards cannot blow out in wet weather. Plastic offers excellent impact resistance. Compatible with PH223 and PH227 holders

PH221
(Clear shield only)



DOT Worded Truck Flip Placards (USA Version)

Our exclusive design is built for durability. Heavy duty aluminum back plate with baked-on polyester finish to resist fading. The legends are screen printed on corrosion resistant aluminum panels. Stainless steel spring clips are mounted to hold the pages in place and all corners are rounded for easy handling. The aluminum base is available in white enamel finish or mill finish.

Size: 13-3/4" x 13-3/4"



5 Page Flip Placard

Inhalation Hazard (Class 2.3)
Oxidizing Gases (Class 2)
Flammable Gases (Class 2.1)
Non-Flammable Gases (Class 2.2)
Blank White

Size: 13-3/4" x 13-3/4"

FC8005WH (Painted White)

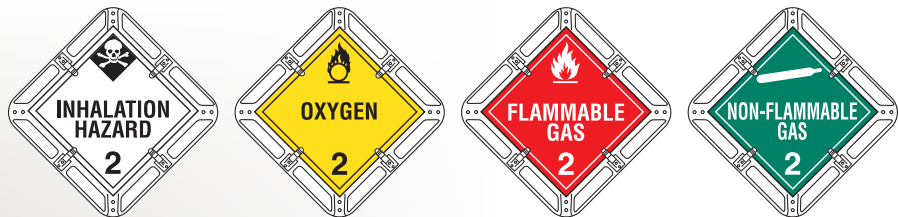

8 Page Flip Placard

Flammable Gases (Class 2.1)
Non-Flammable Gases (Class 2.2)
Flammable Liquids (Class 3)
Oxidizing Substances (Class 5.1)
Poison (Class 6.1)
Inhalation Hazard (Class 6.1)
Corrosive (Class 8)
Danger Mixed Loads

Size: 13-3/4" x 13-3/4"

FC8050WH (Painted White)

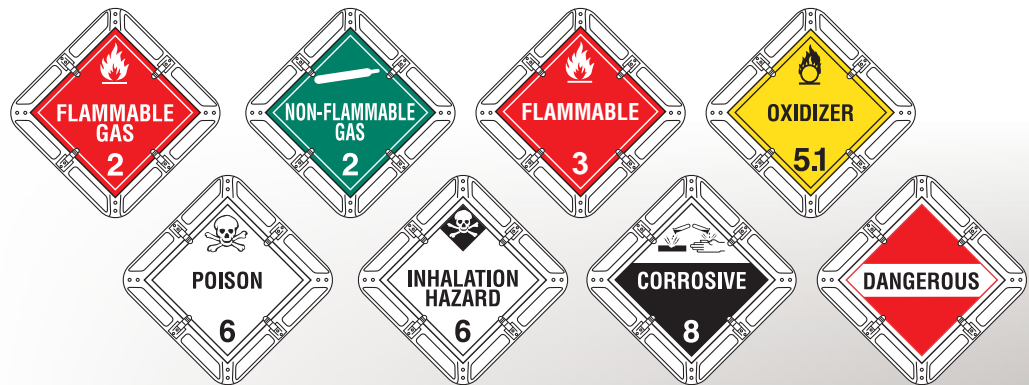

9 Page Flip Placard

Flammable Gases (Class 2.1)
Non-Flammable Gases (Class 2.2)
Flammable Liquids (Class 3)
Oxidizing Substances (Class 5.1)
Poison (Class 6.1)
Radioactive Materials (Class 7)
Corrosive (Class 8)
Danger Mixed Loads
Blank White

Size: 13-3/4" x 13-3/4"

FC8010WH (Painted White)

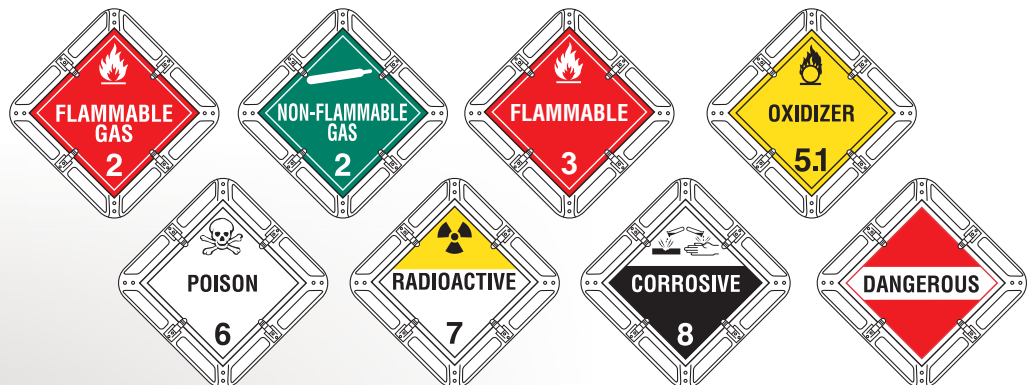

15 Page Flip Placard

- Flammable Gases (Class 2.1)
- Non-Flammable Gases (Class 2.2)
- Inhalation Hazard (Class 2.3)
- Flammable Liquids (Class 3)
- Flammable Solids (Class 4.1)
- Substances Liable to Spontaneous Combustion (Class 4.2)
- Water Reactive Substances (Class 4.3)
- Oxidizing Substances (Class 5.1)
- Organic Peroxides (Class 5.2)
- Toxic (Class 6.1)
- Inhalation Hazard (Class 6.1)
- Corrosive (Class 8)
- Misc. Products Substances or Organisms (Class 9)
- Danger Mixed Loads
- Blank White

Size: 13-3/4" x 13-3/4"

FC8015WH (Painted White)



15 Page Flip Placard

- Flammable Gases (Class 2.1)
- Non-Flammable Gases (Class 2.2)
- Inhalation Hazard (Class 2.3)
- Flammable Liquids (Class 3)
- Combustible Liquids (Class 3)
- Flammable Solids (Class 4.1)
- Substances Liable to Spontaneous Combustion (Class 4.2)
- Water Reactive Substances (Class 4.3)
- Oxidizing Substances (Class 5.1)
- Poison (Class 6.1)
- Inhalation Hazard (Class 6.1)
- PG II (Class 6.1)
- Corrosive (Class 8)
- Misc. Products Substances or Organisms (Class 9)
- Danger Mixed Loads

Size: 13-3/4" x 13-3/4"

FC8030WH (Painted White)



TDG Truck Flip Placards

(Canada & International)

Our exclusive design is built for durability, heavy duty aluminum back plate with baked-on polyester finish to resist fading. The legends are screen printed on corrosion resistant aluminum panels. Stainless steel spring clips are mounted to hold the pages in place and all corners are rounded for easy handling. The aluminum base is available in white enamel finish or mill finish.

Size: 13-3/4" x 13-3/4"



4 Page Flip Placard

- 1.1D (Class 1)
- 1.1B (Class 1)
- 1.4B (Class 1)
- 1.5D (Class 1)

Size: 13-3/4" x 13-3/4"

FC7000WH (Painted White)



5 Page Flip Placard

- Flammable Gas (Class 2)
- Compressed Gas (Class 2)
- Flammable Liquids (Class 3)
- Corrosive (Class 8)
- DANGER

Size: 13-3/4" x 13-3/4"

FC5010WH (Painted White)



Flip Placard Clip

Use our stainless steel clips to replace broken or missing clips from any flip placard system.

FCCLIP

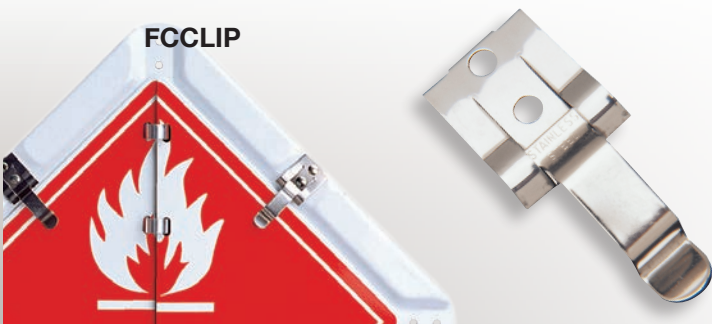

Placard Holder Clip

Use our stainless steel clip to repair or replace any placard style holder on the market. Has a fold back flat style to allow for easy placard removal.

PHCLIP



6 Page Flip Placard

Flammable Liquids (Class 3)
 Oxidizers (Class 5.1)
 Toxic Substances (Class 6.1)
 Corrosive (Class 8)
 DANGER
 Blank White

Size: 13-3/4" x 13-3/4"

FC5030WH (Painted White)



9 Page Flip Placard

Flammable Gas (Class 2)
 Compressed Gas (Class 2)
 Flammable Liquids (Class 3)
 Oxidizers (Class 5.1)
 Toxic Substances (Class 6.1)
 Radioactive (Class 7)
 Corrosive (Class 8)
 DANGER
 Blank White

Size: 13-3/4" x 13-3/4"

FC5020WH (Painted White)



14 Page Flip Placard

Flammable Gas (Class 2)
 Compressed Gas (Class 2)
 Poison Gas (Class 2)
 Flammable Liquids (Class 3)
 Flammable Solid (Class 4)
 Dangerous When Wet (Class 4)
 Oxidizers (Class 5.1)
 Organic Peroxides (Class 5.2)
 Toxic Substances (Class 6.1)
 Radioactive (Class 7)
 Corrosive (Class 8)
 Miscellaneous (Class 9)
 DANGER
 Blank White

Size: 13-3/4" x 13-3/4"

FC5000WHR (Painted White)



Fuel Flip Placards

(USA, Canada & International)

These fuel flip placard can be ordered with either a natural aluminum base or a bright white base to suit your truck. Please specify base color when placing order. Units are constructed of all aluminum and stainless steel parts for added longevity.

Size: 13-3/4" x 13-3/4"



NATURAL ALUMINUM

PAINTED WHITE

2 Page Fuel Flip Placard

Class 3 Flammable Liquid with
UN 1202
UN 1203

Size: 13-3/4" x 13-3/4"

2 Page FC4020AL (Natural Aluminum)
2 Page FC4020WH (Painted White)



3 Page Fuel Flip Placard

Class 3 Flammable Liquid with
UN 1202
UN 1203
UN 1267

Size: 13-3/4" x 13-3/4"

3 Page FC4050AL (Natural Aluminum)
3 Page FC4050WH (Painted White)



3 Page Fuel Flip Placard

Class 3 Flammable Liquid with
UN 1202
UN 1203
UN 1863

Size: 13-3/4" x 13-3/4"

3 Page FC4030AL (Natural Aluminum)
3 Page FC4030WH (Painted White)



4 Page Fuel Flip Placard

Class 3 Flammable Liquid with
UN 1202
UN 1203
UN 1863
UN 3475.

Size: 13-3/4" x 13-3/4"

4 Page FC4040AL (Natural Aluminum)
4 Page FC4040WH (Painted White)



6 Page Fuel Flip Placard

Class 3 Flammable Liquid with
UN 1202
UN 1203
UN 1268
UN 1863
UN 1993
UN 3475

Size: 13-3/4" x 13-3/4"

6 Page FC4060AL (Natural Aluminum)
6 Page FC4060WH (Painted White)

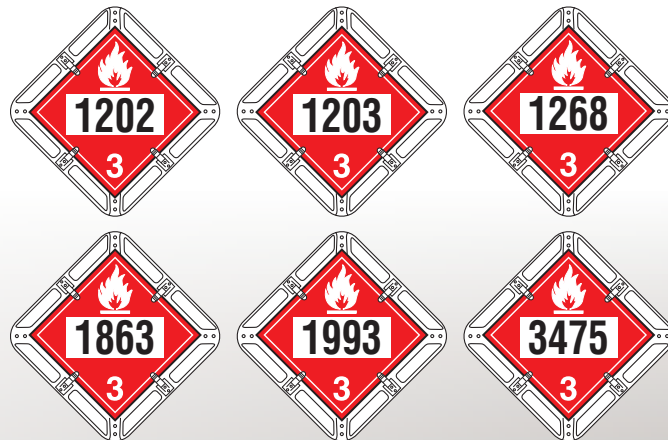

Custom Flip Placard System

Choose any of the legends in any combination that you need.

Call for more details.



Flip Placard with Rotating Numbers

Versatile flip placards from INCOM help make changing numbered placards quick and easy. This flip placard system contains both Canadian & US legends. Our exclusive design is built for durability, heavy .031" aluminum back plate with baked-on polyester finish to resist fading. The legends are screen printed on corrosion resistant aluminum panels. Stainless steel spring clips are mounted to hold the pages in place and all corners are rounded for easy handling.

Size: 13-3/4" x 13-3/4"



5 Page Flip Placard

Flammable (Class 3) DOT & TDG
 Combustible (Class 3) DOT
 Poison (Class 6) DOT & TDG
 Corrosive (Class 8) DOT & TDG
 Blank White

Size: 13-3/4" x 13-3/4"

FC6Ø15AL (Natural Aluminum)

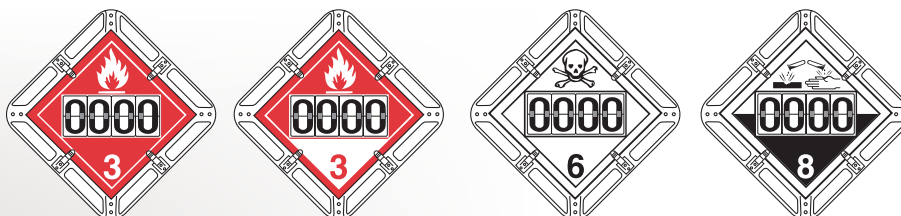

6 Page Flip Placard

Flammable (Class 3) DOT & TDG
 Oxidizer (Class 5.1) DOT & TDG
 Inhalation Hazard (Class 6) DOT
 Poison (Class 6) DOT & TDG
 Corrosive (Class 8) DOT & TDG
 Blank White

Size: 13-3/4" x 13-3/4"

FC6Ø1ØWH (Painted White)



9 Page Flip Placard

Inhalation Hazard (Class 2) DOT
 Combustible (Class 3) DOT
 Flammable (Class 3) DOT & TDG
 Oxidizer (Class 5.1) DOT & TDG
 Inhalation Hazard (Class 6) DOT
 Poison (Class 6) DOT & TDG
 Corrosive (Class 8) DOT & TDG
 Miscellaneous (Class 9) DOT & TDG
 Blank White

Size: 13-3/4" x 13-3/4"

FC6ØØØAL (Natural Aluminum)

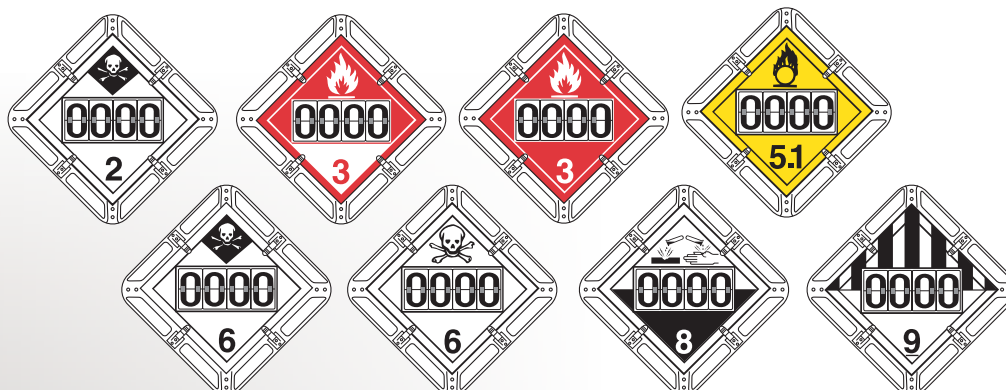

Rigid-Flip Rectangle Page Flip Placard

The FC9000 series "Rigid-Flip" placards are a versatile flip placard with features that differ from our standard model. The construction of the pages has an added benefit utilizing a cutout in the page so each clip arm seats securely in place to help reduce both page wear and clip loss during use. Page turning is made easy by two finger cutouts adjacent to each other on the frame. This allows the user access to the edge of the pages and select the desired legend. All weather versatility with large ridges that run along all 4 sides of the thick durable base for added strength. Rectangular shape of pages, coupled with the location of hinges and stainless steel clips being closer to corners and edge helps to reduce curled page edges for added safety. Made from a ultra durable 0.04" thick aluminum.

Rigid-Flip placard systems are 15" between clipped corners for use on most roll up style doors. Contact us for the full range of standard and custom options for this new flip placard product.

Size: 14.5" x 14.5"

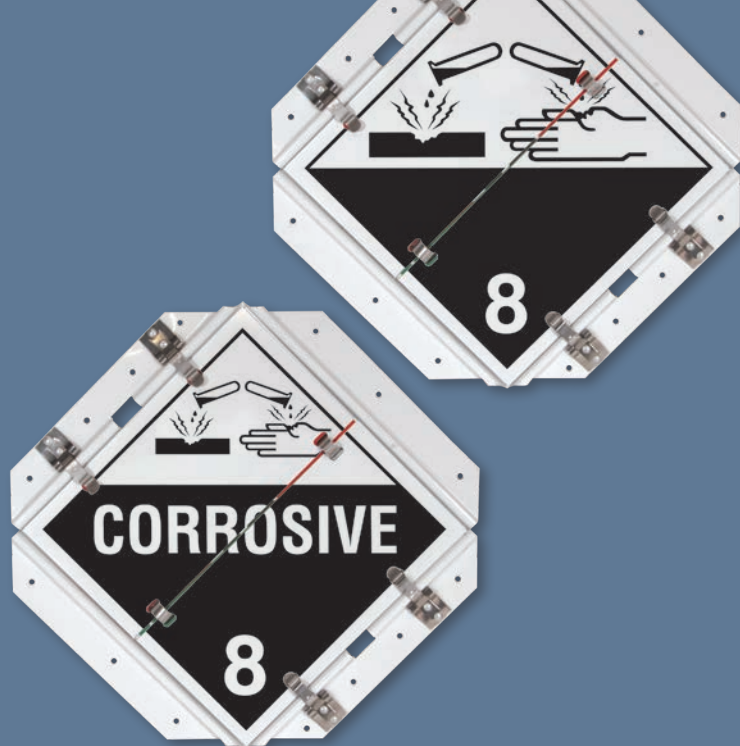

2 Page Rigid-Flip Placard

(USA, Canada & International)

Class 3 Flammable Liquid with UN number 1202 and 1203.

Size: 14.5" x 14.5"

FC9020 (Painted White)



Non-Worded 9 Page Rigid-Flip Placard

(Canada & International)

Class 2 Flammable Gas, Class 2.1 Non-Flammable Gas, Class 3 Flammable Liquid, Class 5.1 Oxidizer, Class 6.1 Toxic Substances, Class 7 Radioactive, Class 8 Corrosive DANGER and Blank White.

Size: 14.5" x 14.5"

9 Page FC9009 (Painted White)



Worded 9 Page Rigid-Flip Placard

(USA Version)

Class 2 Flammable Gas, Class 2.1 Non-Flammable Gas, Class 3 Flammable Liquid, Class 5.1 Oxidizer, Class 6.1 Poison, Class 7 Radioactive, Class 8 Corrosive DANGEROUS and Blank White.

Size: 14.5" x 14.5"

9 Page FC9010 (Painted White)

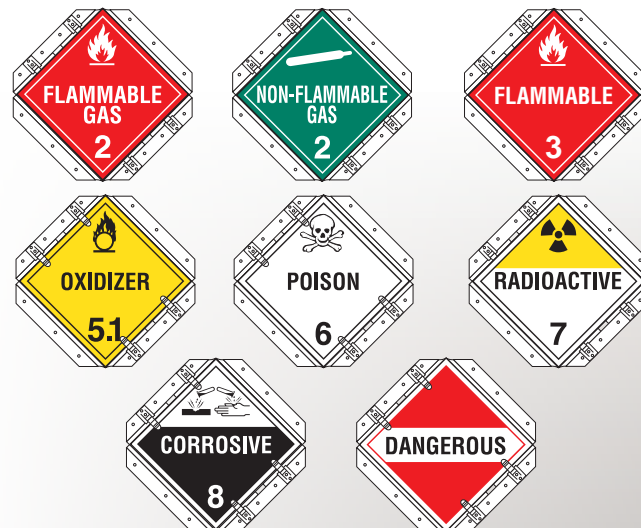

Vehicle Safety Decals

Our vehicle safety decals are perfect for marking notices and safety equipment to drivers. Decals have been laminated with a thick polyester UV-resistant film for added outdoor durability and chemical resistance when mounted on vehicles.

4" x 4" printed on outdoor adhesive VynMark with polyester UV lamination. Sold 25 per pack.



DEC100



DEC103



DEC101



DEC104



DEC109



DEC105



DEC107

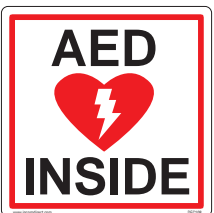

DEC108



DEC102



DEC110



DEC106



DEC111

Speciality Handling Labels

Labels

Identify specific handling requirements for your goods with our speciality handling labels. We manufacture them using a white high gloss paper stock with an aggressive permanent adhesive.

Labels are shipped 500/roll, with the exception of the "Made In Canada" labels which are shipped 1000/roll only.



1079
3" x 6"



1093
4" x 4"



1631
6" x 1.5"



1095
5" x 4.5"



1113P
1" x 1"



1019
5" x 3"



1122P
3/4" x 1/2"



1087
4" x 4"



1088
4" x 4"

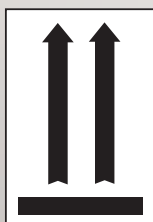

1064B
4" x 6"

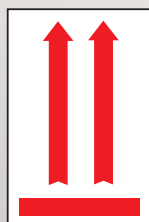

1064R
4" x 6"



1058
4" x 6"



1067
4" x 6"



1071
4" x 6"

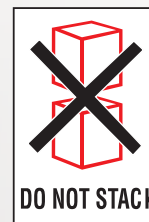

1074
4" x 6"



1055
4" x 6"



1057
4" x 6"

Transport Trailer Safety Signs

Our durable truck signs are silk screen printed on an outdoor grade VynMark for long term durability. Make sure drivers are aware of the limited operation of your vehicle.

Custom Designs Available. Call for Details.

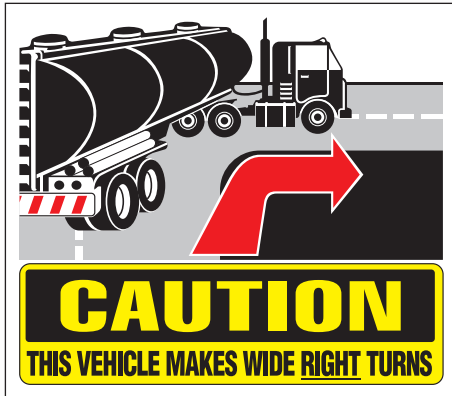

WT1592 - 16" x 14"



WT1593 - 11-1/2" x 16"



WT1590 - 13" x 9"



WT1595 - 17" x 9"



WT1594 - 17" x 11"

Inventory Coding Labels

Perfect for marking inventory and anything else that needs to be coded for identification purposes. We manufacture our color coded labels in a wide variety of colors and sizes to suit any application.

They are made using a high gloss paper stock with permanent adhesive. Labels are sold 1000 per roll.

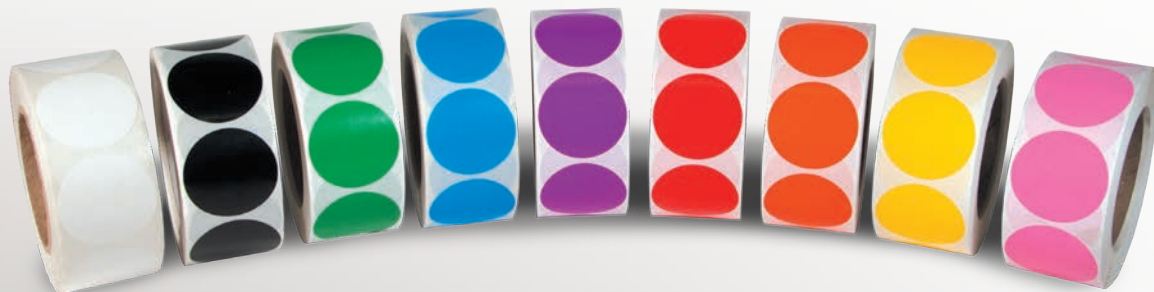

Size	Red	Blue	Green	Yellow	Pink	White	Orange	Purple	Black
3/4"	1305	1306	1307	1308	1309	1310	1311	1312	1313
1"	1314	1315	1316	1317	1318	1319	1320	1321	1322
2"	1332	1333	1334	1335	1336	1337	1338	1339	1340

ISO 17712:2013

C O M P L I A N T

High Security Bolt Seal

APPLICATION

- Trailer Doors Latches
- Container Door Latches

FEATURES

- Meets ISO 17712:2013 compliant (C-TPAT)
- Both parts can be numbered to prevent fraud by replacement of either Bolt or Body
- Parts come attached in a unique package for ease of use and accurate tracking of numbers
- Anti-spin feature ensures the seal is locked when closed
- Removal requires bolt cutters
- Total length 3-3/4" with a 2-1/4" barrel for locking



TS7000Y
Yellow - 200/case

TS700Y
Yellow - 10/pack



California Regulatory Warning

 **WARNING:** Cancer and Reproductive Harm - www.P65Warnings.ca.gov.

High Security Cable Seal

High security, metal, temper evident, flexible cable seal. Lock body available in two colors. Cable is 3.5mm thickness.

APPLICATION

- Trucks/Trailers
- Meter Boxes
- Tote Boxes
- Rail Cars
- Containers
- Valves

FEATURES

- Meets ISO 17712:2013 compliant (C-TPAT)
- Die cast aluminum lock body can be in various colors
- Laser marking of numbers as well as barcodes
- Remove with cable cutter
- Standard length is 12 inches. Cable lengths can be varied according to requirements



TS5000B
Blue - 250/case

TS500B

Blue - 10/pkg

TS5000K

Black - 250/case

TS500K

Black - 10/pkg



California Regulatory Warning

 **WARNING:** Cancer and Reproductive Harm - www.P65Warnings.ca.gov.

Pull-Tight Seal

Adjustable strap seal with dual locking mechanism

APPLICATION

- Trucks/Trailers
- Refineries
- Postal bags
- Cash bags
- Warehouse
- Fuel oil tankers

FEATURES

- Dual Locking mechanism
- Beaded strap provide addition grip with applied surface
- Carefully designed strap diameter that enable sealing apertures
- Laser printing provides highest level of security
- Suitable for temperatures ranging from -20° C to 80° C
- Overall length 14 inches



TS3500R
Red - 1000/case

TS350R

Red - 100/pack

TS3500W

White - 1000/case

TS350W

White - 100/pack

California Regulatory Warning

 **WARNING:** Cancer and Reproductive Harm - www.P65Warnings.ca.gov.

Dual-Lock Seal

Dual-Lock Seal is a fixed length seal made from polypropylene plastic. It has an acetal jaw and unique double locking mechanism specially designed to enhance its security against tampering.

APPLICATION

- Vehicle doors
- Tankers - petroleum, bulk foods & liquids
- Shipping containers

FEATURES

- Fixed loop design, with an 8 inch overall length
- Patented double locking mechanism & ribbed locking head
- Acetal locking jaw with a higher melting point than polypropylene
- Pre-determined break point on the seal



California Regulatory Warning
WARNING: Cancer and Reproductive Harm - www.P65Warnings.ca.gov

Easy-Break Seal

Easy-Break Seal has been developed primarily for sealing safety equipment after their annual test and certification. The low break strength (14 lbs / 6 Kgs) allows for manual removal in cases of emergency.

APPLICATION

- Regulated emergency devices

FEATURES

- Has a low breaking strength (14 lbs / 6 Kgs)
- Available in two standard colors
- Total length is 9-3/4 inches
- Can be printed with customer name and sequential serial number

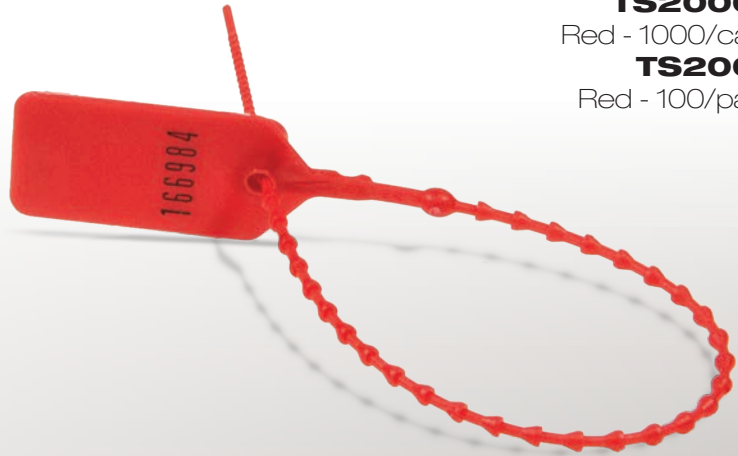

California Regulatory Warning
WARNING: Cancer and Reproductive Harm - www.P65Warnings.ca.gov

Padlock Seal

This easy to apply padlock seal features a stainless steel wire hasp which can be scored for added protection and easy removal.

APPLICATION

- Utility Meters
- Switches
- Valves
- Vending Machines
- Keys
- Medical Cabinets

FEATURES

- Consecutive and alphabetically prefixed hot-stamped numbers are available
- Name and/or logo can be hot-stamped
- Any attempt to tamper with seal is clearly evident
- Ultra Violet stabilized
- Overall length 2-1/2" with a 7/8" loop

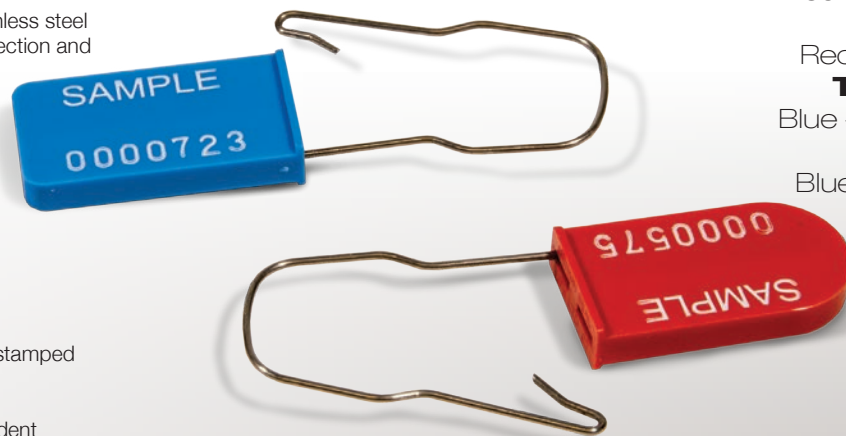

California Regulatory Warning
WARNING: Cancer and Reproductive Harm - www.P65Warnings.ca.gov

TS1000R
 Red - 1000/case
TS100R
 Red - 100/pack

TS2000R
 Red - 1000/case
TS200R
 Red - 100/pack

TS4000R
 Red - 1000/case
TS400R
 Red - 100/pack
TS4000B
 Blue - 1000/case
TS400B
 Blue - 100/pack

What is the NFPA?



National
Fire
Protection
Association

The National Fire Protection Association (NFPA) is a non-profit organization devoted to eliminating death, injury, property and economic loss due to fire, electrical and related hazards.

The NFPA Diamond

The NFPA hazard diamond is a commonly used standard of identification of the hazards of chemicals and materials.

The easily read visual details help emergency first responders quickly identify the hazardous chemical, by using the rating numbers and symbols.

Learn more about NFPA at www.nfpa.org

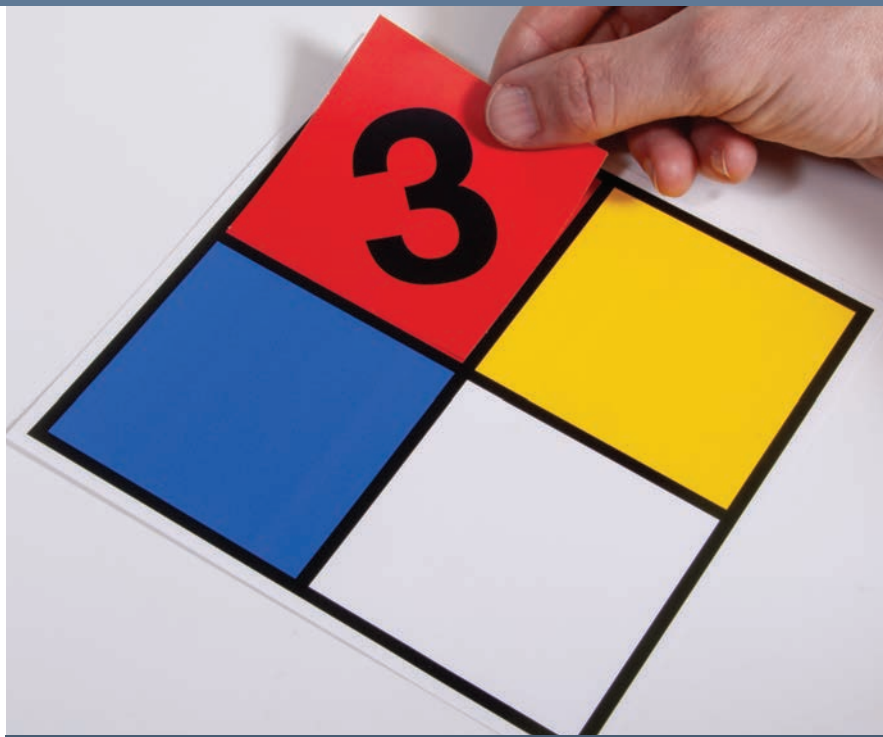

Understanding the NFPA 704 Diamond

This is diamond-shaped NFPA 704 style sign with four smaller quadrants inside. One diamond is blue, one is red, one is yellow and one is white. The diamond-shaped signs use the four color-coded categories identify the hazards that personnel or observers are exposed to in any specific area with just a quick visual inspection of the sign diamond. The image to the right shows the different colored sections and what they represent.

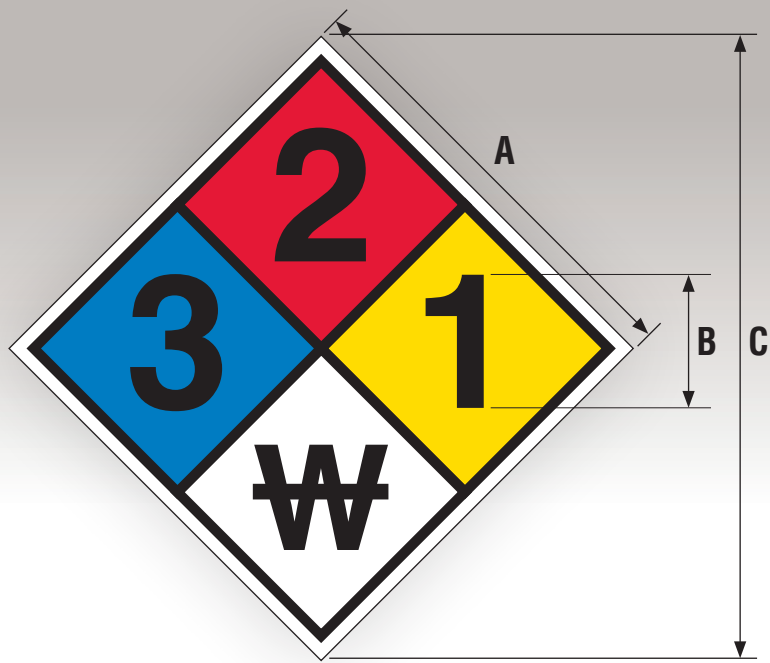
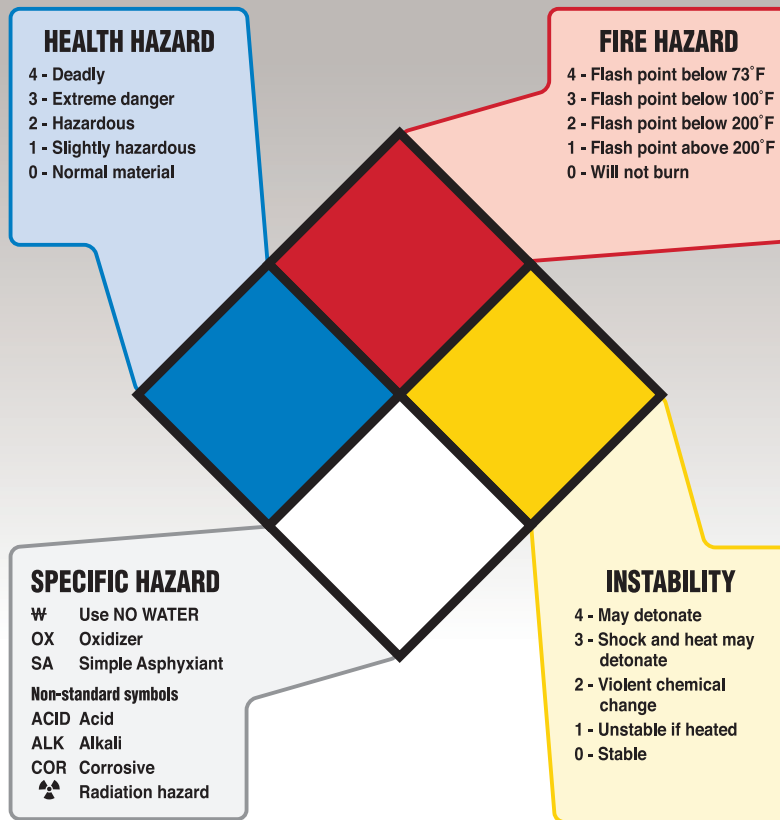

Recommended Viewing Distance

The size of the diamond and the associated numbers and symbols is dependent on the distance at which the hazard ratings can be safely viewed in the event of an accident.

According to the NFPA 704 Standard, a ratio of 25 feet of viewing distance per inch of text should be used to determine the minimum text size required, up to 100 feet.

A Diamond Size	B Character Size	C Diamond Height	Legible Viewing Distance
3" x 3"	1"	4.25"	1 to 40 ft
6" x 6"	2"	8.5"	41 to 85 ft
9" x 9"	3"	12.75"	86 to 135 ft
11" x 11"	4"	15.5"	136 to 150 ft
15" x 15"	6"	21.25"	151 to 200 ft
20" x 20"	8"	28.25"	201 to 300 ft
24" x 24"	10"	34"	301 to 400 ft

NFPA Hazardous Materials Signs

NFPA workplace safety signs give a clear and obvious display of the NFPA hazards and symbology. Signs include the commonly seen NFPA diamond along with details as to the hazards it represents.

Helps identify the extent of a health or fire hazard with a chemical using the NFPA diamond system. Commonly used in workplaces using the NFPA hazard identification system. Available in an assortment of materials to suit your application.

HOW TO ORDER:

SELECT SIGN - **SS5000** SELECT SIGN TYPE - **V** ADD TOGETHER - **SS5000V**

SIGN ARMOR			
Weather, Chemical, Abrasion & Graffiti Resistant Coating			
V	P	A	MV
Adhesive VynMark	Semi-Rigid Plastic	Aluminum	Magnetic Sheeting

OVER-LAMINATION FILM		
High Performance Outdoor UV Film		
VL	PL	AL
Adhesive VynMark	Semi Rigid Plastic	Aluminum



Custom NFPA Hazard Rating Diamond

Send us the chemical name and hazard classifications for us to make up professional looking signs for your regulatory requirements. Call our customer service department for details.

To obtain your sign hazard rating you'll will need to look at your SDS sheets or refer to Fire Protection Guide to Hazardous Materials.



SA4500 - 7" x 10"
SS4500 - 10" x 14"
SC4500 - 14" x 20"



SA4501 - 7" x 10"
SS4501 - 10" x 14"
SC4501 - 14" x 20"

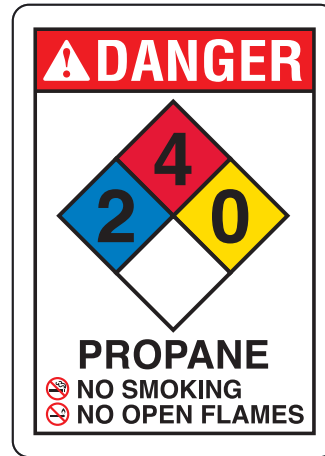

SA4502 - 7" x 10"
SS4502 - 10" x 14"
SC4502 - 14" x 20"



SA4503 - 7" x 10"
SS4503 - 10" x 14"
SC4503 - 14" x 20"



SA4504 - 7" x 10"
SS4504 - 10" x 14"
SC4504 - 14" x 20"



SA4505 - 7" x 10"
SS4505 - 10" x 14"
SC4505 - 14" x 20"

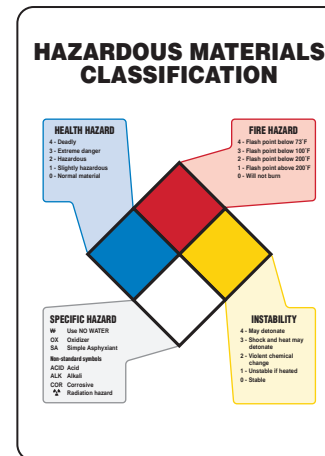

SA4506 - 7" x 10"
SS4506 - 10" x 14"
SC4506 - 14" x 20"



SA4507 - 7" x 10"
SS4507 - 10" x 14"
SC4507 - 14" x 20"

NFPA 704 Diamond

NFPA workplace diamond gives a clear and obvious display of the NFPA hazards and symbology. Signs include the commonly seen NFPA diamond along with labels to apply different hazard numbers and symbols to change the sign to suit the specific chemical hazard. Numbers and symbols are included in the kit version of these signs and the user can apply them to meet their needs. Blank diamonds are also sold separately.

Helps identify the extent of a health or fire hazard with a chemical using the NFPA diamond system. Commonly used in workplaces using the NFPA hazard identification system.

We can also pre-print these diamonds with all your required details for an easy and professional looking result. Call us for details.

NFPA diamond only or in kit form

Each Kit Includes

- One NFPA diamond
- 15 numbers 0-4 in blue, red and yellow
- 7 specific hazard symbols

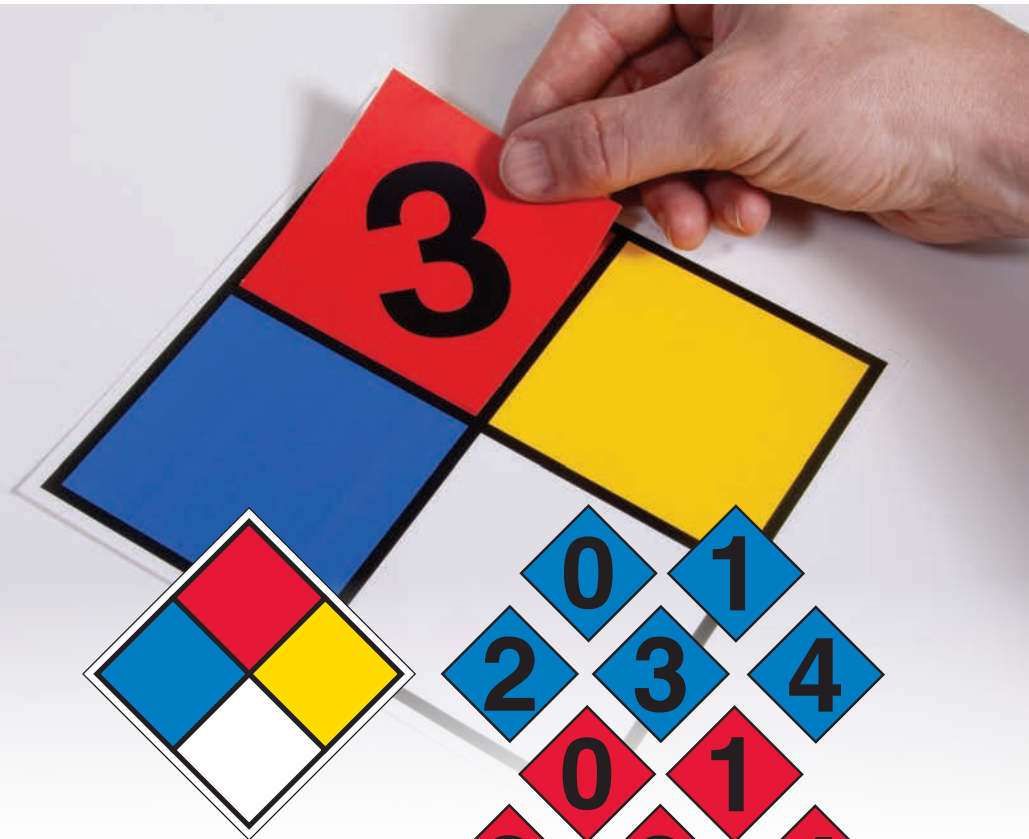

Diamond Size	Character Size	Stock No.	Material	Description
3" x 3"	1"	NFPA100KITV	Adhesive VynMark	NFPA Diamond & Character Set
3" x 3"	1"	NFPA100V	Adhesive VynMark	NFPA Diamond Only
6" x 6"	2"	NFPA101KITV	Adhesive VynMark	NFPA Diamond & Character Set
6" x 6"	2"	NFPA101V	Adhesive VynMark	NFPA Diamond Only
6" x 6"	2"	NFPA101KITP	Rigid Plastic	NFPA Diamond & Character Set
6" x 6"	2"	NFPA101P	Rigid Plastic	NFPA Diamond Only
9" x 9"	3"	NFPA102KITV	Adhesive VynMark	NFPA Diamond & Character Set
9" x 9"	3"	NFPA102V	Adhesive VynMark	NFPA Diamond Only
9" x 9"	3"	NFPA102KITP	Rigid Plastic	NFPA Diamond & Character Set
9" x 9"	3"	NFPA102P	Rigid Plastic	NFPA Diamond Only
9" x 9"	3"	NFPA102KITA	Aluminum	NFPA Diamond & Character Set
9" x 9"	3"	NFPA102A	Aluminum	NFPA Diamond Only
11" x 11"	4"	NFPA103KITV	Adhesive VynMark	NFPA Diamond & Character Set
11" x 11"	4"	NFPA103V	Adhesive VynMark	NFPA Diamond Only
11" x 11"	4"	NFPA103KITP	Rigid Plastic	NFPA Diamond & Character Set
11" x 11"	4"	NFPA103P	Rigid Plastic	NFPA Diamond Only
11" x 11"	4"	NFPA103KITA	Aluminum	NFPA Diamond & Character Set
11" x 11"	4"	NFPA103A	Aluminum	NFPA Diamond Only
15" x 15"	6"	NFPA104KITV	Adhesive VynMark	NFPA Diamond & Character Set
15" x 15"	6"	NFPA104V	Adhesive VynMark	NFPA Diamond Only
15" x 15"	6"	NFPA104KITP	Rigid Plastic	NFPA Diamond & Character Set
15" x 15"	6"	NFPA104P	Rigid Plastic	NFPA Diamond Only
15" x 15"	6"	NFPA104KITA	Aluminum	NFPA Diamond & Character Set
15" x 15"	6"	NFPA104A	Aluminum	NFPA Diamond Only
20" x 20"	8"	NFPA105KITV	Adhesive VynMark	NFPA Diamond & Character Set
20" x 20"	8"	NFPA105V	Adhesive VynMark	NFPA Diamond Only
20" x 20"	8"	NFPA105KITP	Rigid Plastic	NFPA Diamond & Character Set
20" x 20"	8"	NFPA105P	Rigid Plastic	NFPA Diamond Only
20" x 20"	8"	NFPA105KITA	Aluminum	NFPA Diamond & Character Set
20" x 20"	8"	NFPA105A	Aluminum	NFPA Diamond Only
24" x 24"	10"	NFPA106KITV	Adhesive VynMark	NFPA Diamond & Character Set
24" x 24"	10"	NFPA106V	Adhesive VynMark	NFPA Diamond Only
24" x 24"	10"	NFPA106KITP	Rigid Plastic	NFPA Diamond & Character Set
24" x 24"	10"	NFPA106P	Rigid Plastic	NFPA Diamond Only
24" x 24"	10"	NFPA106KITA	Aluminum	NFPA Diamond & Character Set
24" x 24"	10"	NFPA106A	Aluminum	NFPA Diamond Only



Custom NFPA Hazard Rating Diamond

Select the character you require and we will print directly on the NFPA diamond.

To obtain your sign hazard rating you'll will need to look at your SDS sheets or refer to Fire Protection Guide to Hazardous Materials.

NFPA Wallet Guide

Use our NFPA wallet guide to keep a quick and handy reference to the NFPA hazards and symbology. Helps identify the extent of a health or fire hazard with a chemical using the NFPA diamond system. Commonly used in workplaces using the NFPA hazard identification system.

Wallet Guide size: 3.375" x 2.125"

NFPA2000



FRONT

HAZARDOUS MATERIALS CLASSIFICATION

<p>HEALTH HAZARD</p> <p>4 - Deadly 3 - Extreme danger 2 - Hazardous 1 - Slightly hazardous 0 - Normal material</p>		<p>FIRE HAZARD</p> <p>4 - Flash point below 73° F 3 - Flash point below 100° F 2 - Flash point below 200° F 1 - Flash point above 200° F 0 - Will not burn</p>
<p>SPECIFIC HAZARD</p> <p>W Use NO WATER OX Oxidizer SA Simple Asphyxiant</p> <p>Non-standard symbols ACID Acid ALK Alkali COR Corrosive ☼ Radiation hazard</p>	<p>INSTABILITY</p> <p>4 - May detonate 3 - Shock and heat may detonate 2 - Violent chemical change 1 - Unstable if heated 0 - Stable</p>	

BACK

HAZARDOUS MATERIALS CODE IDENTIFICATION

HEALTH	FLAMMABLE	INSTABILITY
Recommended protection	Susceptibility to burning	Susceptibility to energy release
<p>4 Deadly - Special full protective suit and breathing apparatus must be worn.</p> <p>3 Danger - Full protective suit and breathing apparatus should be worn.</p> <p>2 Hazardous - Breathing apparatus with full face mask should be worn.</p> <p>1 Slightly hazardous - Breathing apparatus may be worn.</p> <p>0 Normal - No precautions necessary.</p>	<p>4 Below 73°F - Very flammable</p> <p>3 Below 100°F - Ignites under normal temperature conditions.</p> <p>2 Below 200°F - Ignites with moderate heating.</p> <p>1 Above 200°F - Ignites when preheated</p> <p>0 Will not burn</p>	<p>4 May detonate under normal conditions.</p> <p>3 May detonate with shock or heat.</p> <p>2 Violent chemical change but does not detonate.</p> <p>1 Not stable if heated use precautions.</p> <p>0 Normally stable</p>

NFPA Label Rolls

NFPA workplace safety labels give a clear and obvious display of the NFPA hazards and symbology. Labels include the commonly seen NFPA diamond along with areas to fill in specific details of the chemical hazard. Labels will adhere to most clean dry surfaces.

Helps identify the extent of a health or fire hazard with a chemical using the NFPA diamond system. Commonly used in workplaces using the NFPA hazard identification system.



Chemical Name

Common Name

Manufacturer

NFPA2001 - 1.5" x 4"
500/roll

Chemical Name

Owner

Date

NFPA2002 - 1.5" x 4"
500/roll

NFPA Hazardous Material Tags



NFPA workplace safety tags give a clear and obvious display of the NFPA hazards and symbology. Tags include the commonly seen NFPA diamond along with details as to the hazards it represents. Helps identify the extent of a health or fire hazard with a chemical using the NFPA diamond system. Commonly used in workplaces using the NFPA hazard identification system.

HOW TO ORDER:

SELECT TAG - TG7000	SELECT TAG TYPE - PT	ADD TOGETHER. - TG7000PT	RL
	10-mil Poly Tag 3/8" diameter drilled hole.	15-mil Rigid DuraPoly 3/8" diameter metal grommet to add strength.	20-mil Rigid Laminated DuraPoly 3/8" diameter large grommet for extra strength.

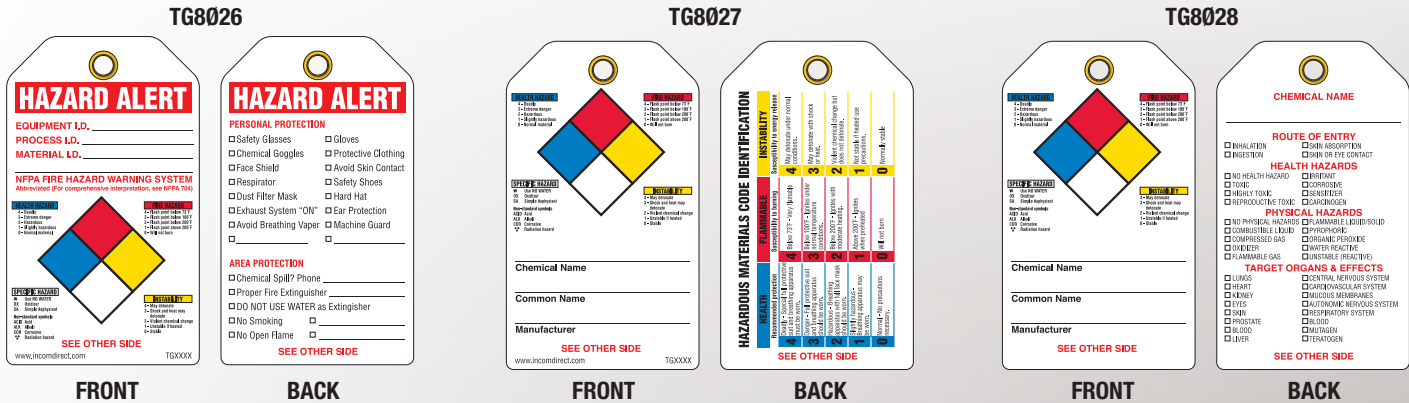

NFPA Flip Placard

NFPA workplace flip placard diamond gives a clear and obvious display of the NFPA hazards and symbology. Flip placard sign include the commonly seen NFPA diamond along with the ability to flip through the different hazard numbers and symbols to change the sign to suit different chemical hazards. Constructed from aluminum with stainless steel clips for longevity

Helps identify the extent of a health or fire hazard with a chemical using the NFPA diamond system. Commonly used in workplaces using the NFPA hazard identification system.

NFPA3000



Globally Harmonized System

HazCom 2012
and
WHMIS 2015



HazCom 2012

Hazard
Communication

WHMIS 2015

Workplace **H**azardous
Materials **I**nformation **S**ystem

What are the different versions of GHS?

While the regulations of HazCom 2012 (US) and WHMIS 2015 (Canada) are closely aligned, they do have slight variations in classification and labeling. For example, all labels and SDSs in WHMIS 2015 (Canada) must be in both English and French, while the HazCom 2012 (US) labels and SDSs must be in English only. Other variances include a hazard class for Biohazardous Infectious Materials (BIM) and pictogram for WHMIS 2015 (Canada), which does not exist for HazCom 2012 (US), as these materials are not regulated in US workplaces.

To learn more, please visit OSHA's website: www.osha.gov and Health Canada's website: www.canada.ca for additional information.

Under the Globally Harmonized System (GHS), workplace hazardous materials have new Pictograms, Signal Words, and Hazard Statements replacing the existing system. Our products are designed for the specific requirements that these changes bring to workplaces.

Labelling

- Pictogram Labels
- Workplace labels
- Laser & thermal printable
- Workplace Tags and Decals
- Multiple sizes for any application

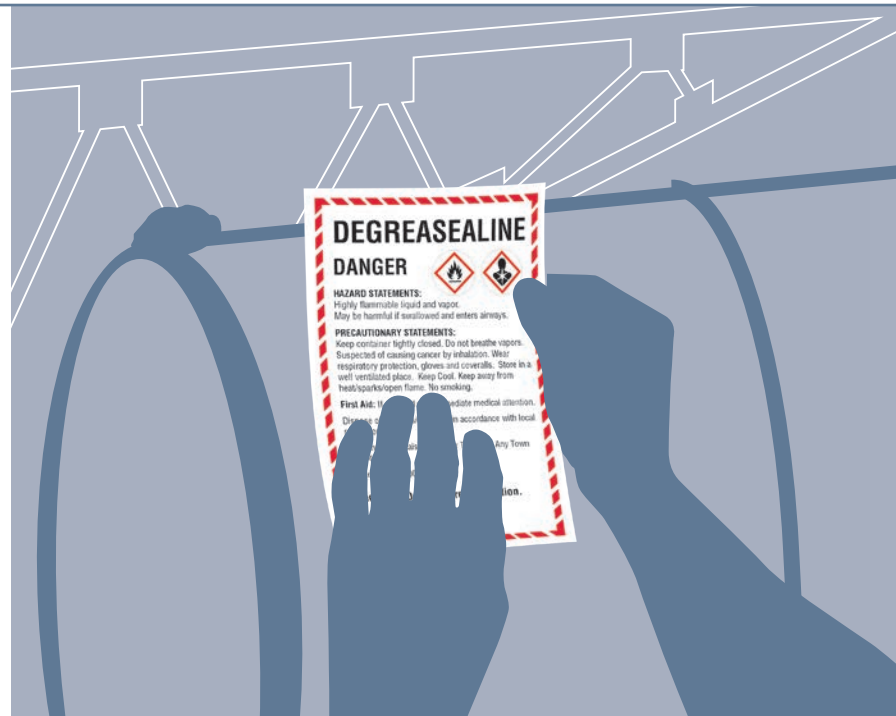

Signage

- SDS Centers
- Information centers
- SDS Binders
- Wall Charts
- Compliance Signs

Information Wall Chart

Our GHS Wall Chart provides a comprehensive overview of new GHS labeling requirements. The chart details the 3 main hazard groups; Physical, Health & Environmental. The requirements for supplier labels when decanting or transferring hazardous chemicals; visual representations of the precautionary statement pictograms; and a list of the information required on a Safety Data Sheet.

Mount this durable, pliable plastic chart in a prominent place to help refresh your employee's knowledge of the GHS requirements. Available in two sizes.



Stock No.	HazCom 2012 (USA) Description
GHS1003	HazCom 2012 Information Wall Chart (24" x 36")
GHS1004	HazCom 2012 Information Wall Chart (18" x 24")
Stock No.	WHMIS 2015 (Canada) Description
GHS1003C	WHMIS 2015 Information Wall Chart (24" x 36")
GHS1004C	WHMIS 2015 Information Wall Chart (18" x 24")
GHS1018	WHMIS 2015 Information Wall Chart - English/French (24" x 36")
GHS1076	WHMIS 2015 Information Wall Chart - English/French (18" x 24")



Pictogram Wall Chart

Our GHS Pictogram Poster is a quick and easy way to convey the new GHS pictograms in the workplace. This wall chart clearly displays the new pictograms and arranges them by their hazard group under the GHS: Physical, Health & Environmental hazards. The wall chart also provides a detailed description of the related hazards. Printed in full color on durable, pliable plastic, this chart is easily mounted on any wall. Units are 24" x 36".

Stock No.	HazCom 2012 (USA) Description
GHS1010	HazCom 2012 Pictogram Wall Chart (24" x 36")
Stock No.	WHMIS 2015 (Canada) Description
GHS1010C	WHMIS 2015 Pictogram Wall Chart (24" x 36")



Simplified Pictogram Wall Chart

Our Simplified Pictogram Chart quickly illustrates the GHS hazard pictograms in a big and bold format. The large sized pictograms are easily read from a distance making it a handy reference for any work environment.

Printed in full color on a durable, pliable plastic, this chart is easily mounted on any wall. Available in two sizes.

Stock No.	Description
GHS1027	Simplified Pictogram Wall Chart (24" x 36")
GHS1028	Simplified Pictogram Wall Chart (18" x 24")
Stock No.	WHMIS 2015 (Bilingual Canadian Version)
GHS1077	WHMIS 2015 Simplified Pictogram Wall Chart - English/French (24" x 36")

Safety Data Sheet

Information Station

Our GHS Information Station provides a central place to easily access all SDS sheets as well as the basic information required for the GHS system. The board is printed with the 3 main hazard groups; Physical, Health & Environmental. The requirements for supplier labels when decanting or transferring hazardous chemicals; visual representations of the precautionary statement pictograms; and a list of the information required on a Safety Data Sheet.

The station is printed in full color on a mounting board and comes with a sturdy metal pocket. Each station also comes with a standard 3 ring SDS printed binder with A - Z alphabetical dividers to sort all of your Safety Data Sheets. The mounting board is constructed of 1/4" rigid plastic with 4 mounting holes to provide easy mounting and years of durability. Available in two sizes.



Stock No.	HazCom 2012 (USA) Description
GHS1001	HazCom 2012 Information Station with 2 binders (24" x 36")
GHS1002	HazCom 2012 Information Station with 1 binder (18" x 24")
Stock No.	WHMIS 2015 (Canada) Description
GHS1001C	WHMIS 2015 Information Station with 2 binders (24" x 36")
GHS1002C	WHMIS 2015 Information Station with 1 binder (18" x 24")
GHS1019	WHMIS 2015 Information Station with 2 binders - English/French (24" x 36")
GHS1072	WHMIS 2015 Information Station with 1 binder - English/French (18" x 24")

Safety Data Sheet Station

Our Safety Data Sheet Information Station provides a central place to easily access all SDS sheets for your plant or office. The Station comes with a sturdy metal pocket designed to hold the included binder. The mounting board is constructed of 1/4" rigid plastic with 4 mounting holes to provide easy mounting and years of durability.

Each station comes with a standard 3 ring SDS printed binder with A - Z alphabetical dividers to sort all of your Safety Data Sheets. Available in 2 sizes.



Stock No.	Description
GHS1011	SDS Station with 2 binders (24" x 36")
GHS1012	SDS Station with 1 binder (18" x 24")
GHS1084	SDS Station with 1 binder (17.5" x 15.5")
Stock No.	WHMIS 2015 (Bilingual Canadian Version)
GHS1020	WHMIS 2015 SDS Station with 2 binders - English/French (24" x 36")
GHS1021	WHMIS 2015 SDS Station with 1 binder - English/French (18" x 24")
GHS1085	WHMIS 2015 SDS Station with 1 binder - English/French (17.5" x 15.5")

Safety Data Sheet Binder

Organize and access your Safety Data Sheets quickly and easily with our Safety Data Sheet Binders. Our binders come in two sizes. The regular size binders come with a standard 1-1/2" D-slant format ring. Our Large binder comes with a 3" D-slant ring for easy storage of large numbers of SDS sheets.

Printed with bright graphics, these binders will be highly visible in your workplace.

All our binders come with sturdy A-Z alphabetical reinforced dividers to sort and organize your Safety Data Sheets.

A
B
C
D
E



Stock No.	Description
GHS1049	Large SDS Binder with A-Z Dividers
GHS1008	SDS Binders with A-Z Dividers
Stock No.	WHMIS 2015 (Bilingual Canadian Version)
GHS1082	WHMIS 2015 Large SDS Binder with A-Z Dividers - English/French
GHS1009	WHMIS 2015 SDS Binders with A-Z Dividers - English/French

Safety Data Sheet

Awareness Decals

These SDS decals can be used on the binder pockets of our Information Stations or simply add it to a wall or storage area for your SDS information.

Decals are 4" x 4" (100mm x 100mm) and come in sheets with 10 per pack. Printed on adhesive VynMark. Available in SDS and FDS formats.

Stock No.	Description
GHS1301	SDS Decal (English)
GHS1302	FDS Decal (French/Spanish)

GHS1301
(English)

SDS

FDS

GHS1302
(French/Spanish)

Safety Data
Sheets

Metal Safety Data Sheet

Storage Case

Our Metal SDS Storage Case provides a durable, protective, and secure area for storage of all your SDS records. Units have two metal closure latches. Our SDS Storage Case has 4 pre-drilled holes and is easily mounted to any wall in your facility. This highly visible case will accommodate any of our SDS binders (sold separately).

Inside Dimensions: 13.75" H x 13.875" W x 5" D

Stock No.	Description
GHS1046	Metal SDS Storage Case



GHS Trained Stickers

These decals are great handouts at the completion of your GHS training sessions.

2.5" in diameter and printed on adhesive VynMark, these decals come 2 per sheet, 5 sheets per package, 10 stickers per package.



Stock No.	Description
GHS1026	GHS Trained Stickers (10/pkg)

Information Decals

This GHS Information decal is a great choice for mounting inside delivery vehicles and on equipment. It covers topics important to employees dealing with product identified under the new GHS standards including the 5 main sections of a GHS Supplier Label and the GHS formatted pictograms, including the optional Environment picto.

The decals are 8.5" wide, by 11" tall, printed on adhesive VynMark. 10 Decals/pack.

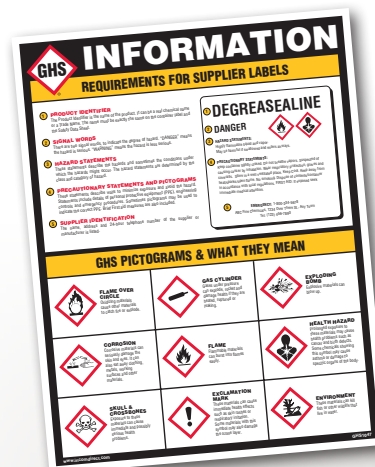

Stock No.	Description
GHS1047	GHS Information Decals (8.5" x 11")

Secondary Workplace Tags & Labels

Our secondary workplace tags and labels clearly identify hazards to your employees. These labels and tags offer an easy to use design to correctly identify the hazard information for labeling secondary containers in your workplace. The tags are made from a waterproof stock that can easily be printed on. The labels are made from a premium peel and stick material with a permanent adhesive.

Both tags and labels are available with a self laminating protective shield that is installed after completing the information, making them chemical and scuff resistant.



GHS1083
(Self-Laminated Tag)



GHS1316
(Self-Laminated Label)

Stock No.	Description
GHS1083	Self-Laminated Tag - (3 $\frac{3}{8}$ " x 5 $\frac{3}{4}$ ") (24/pack)
GHS1318	Tag - (3 $\frac{3}{8}$ " x 5 $\frac{3}{4}$ ") (25/pack)
Stock No.	WHMIS 2015 (Canada) Description
GHS1083F	WHMIS 2015 Self-Laminated Tag - French (3 $\frac{3}{8}$ " x 5 $\frac{3}{4}$ ") (24/pack)
GHS1318F	WHMIS 2015 Tag - French (3 $\frac{3}{8}$ " x 5 $\frac{3}{4}$ ") (25/pack)

Stock No.	Description
GHS1316	Self-Laminated Label - (3" x 6") (24/pack)
GHS1317	Label - (3" x 6") (24/pack)

Make Your Own Workplace Tags

Use our GHS style workplace tags to clearly identify hazards to your employees. Our GHS tags offer a simple template design to build your tag on. The tags are made from a waterproof stock that can easily be printed on and the tags are sized to work with $\frac{1}{2}$ " pictograms and PPE label pads (sold separately). Build your own tags on demand that look professional and communicate your message clearly.

Tags are 3" x 6" made from a durable rip-resistant waterproof stock with a reinforcing 3/8" metal grommet. Sold 25/pkg.



GHS1043
(Self-Laminated)

Stock No.	Description
GHS1043	Self-Laminated Tag - (3" x 6") (25/pack)
GHS1042	Tag - (3" x 6") (25/pack)

Pictogram Placards

10³/₄" x 10³/₄"

These large format GHS Pictograms are 10.75" x 10.75" (273 mm x 273 mm) and perfect for marking your containment vessels or tanks. Printed on adhesive VynMark, these pictograms are easily visible due to their large size. They come with a back split liner for easy application and are sold individually or in packages of 100.



<i>Stock No.</i>	<i>Size</i>
GHS1266	10 ³ / ₄ " x 10 ³ / ₄ "
GHS1257	4" x 4"
GHS1303	2" x 2"



<i>Stock No.</i>	<i>Size</i>
GHS1267	10 ³ / ₄ " x 10 ³ / ₄ "
GHS1258	4" x 4"
GHS1304	2" x 2"



<i>Stock No.</i>	<i>Size</i>
GHS1268	10 ³ / ₄ " x 10 ³ / ₄ "
GHS1259	4" x 4"
GHS1305	2" x 2"



<i>Stock No.</i>	<i>Size</i>
GHS1269	10 ³ / ₄ " x 10 ³ / ₄ "
GHS1260	4" x 4"
GHS1306	2" x 2"



<i>Stock No.</i>	<i>Size</i>
GHS1270	10 ³ / ₄ " x 10 ³ / ₄ "
GHS1261	4" x 4"
GHS1307	2" x 2"



<i>Stock No.</i>	<i>Size</i>
GHS1271	10 ³ / ₄ " x 10 ³ / ₄ "
GHS1262	4" x 4"
GHS1308	2" x 2"



<i>Stock No.</i>	<i>Size</i>
GHS1272	10 ³ / ₄ " x 10 ³ / ₄ "
GHS1263	4" x 4"
GHS1309	2" x 2"



<i>Stock No.</i>	<i>Size</i>
GHS1273	10 ³ / ₄ " x 10 ³ / ₄ "
GHS1264	4" x 4"
GHS1310	2" x 2"



<i>Stock No.</i>	<i>Size</i>
GHS1274	10 ³ / ₄ " x 10 ³ / ₄ "
GHS1265	4" x 4"
GHS1311	2" x 2"



<i>Stock No.</i>	<i>Size</i>
GHS1314	4" x 4"
GHS1315	2" x 2"



Pictogram Labels

4" X 4"

Quickly and easily mark your goods for shipping with our GHS Hazard Pictograms. These pictograms are 4" x 4" (100 mm x 100 mm) and come in rolls of 500 labels. Printed on gloss paper with a peel and stick adhesive, these labels are easily applied to metal or plastic containers.



Pictogram Labels

2" X 2"

Need a smaller format of GHS Pictograms for labelling your goods or documents? Our 2" x 2" GHS pictogram labels come in rolls of 500. Printed on gloss paper with peel and stick adhesive, these labels will apply easily to metal and plastic containers.



GHS Hazard Class & PPE Pictogram Labels

Provide your employees with a quick and easy way to identify Hazard Classes and Personal Protective Equipment requirements. Our labels are manufactured on high gloss paper stock with a permanent pressure sensitive adhesive for ease of application and longer durability. Make clean, professional looking labels in minutes.

Printed in sheets and padded with a cardboard backer for ease of use. Each sheet is perforated to allow removal when completed. Labels are sold in pads. 1" are 1,120 labels per pad and ½" are 1,820 labels per pad.



GHS1208 - 1"
GHS1225 - ½"



GHS1209 - 1"
GHS1226 - ½"



GHS1210 - 1"
GHS1227 - ½"



GHS1211 - 1"
GHS1228 - ½"



GHS1212 - 1"
GHS1229 - ½"



GHS1213 - 1"
GHS1230 - ½"



GHS1214 - 1"
GHS1231 - ½"



GHS1215 - 1"
GHS1232 - ½"



GHS1216 - 1"
GHS1233 - ½"



GHS1312 - 1"
GHS1313 - ½"



GHS1217 - 1"
GHS1234 - ½"



GHS1218 - 1"
GHS1235 - ½"



GHS1219 - 1"
GHS1236 - ½"



GHS1220 - 1"
GHS1237 - ½"



GHS1221 - 1"
GHS1238 - ½"



GHS1222 - 1"
GHS1239 - ½"



GHS1223 - 1"
GHS1240 - ½"



GHS1224 - 1"
GHS1241 - ½"

Hazard Pictogram Variety Pack

These Hazard Class Variety Packs provide an assortment of all the GHS hazard class pictograms in one convenient pack.

The labels are manufactured on high gloss paper stock with removable adhesive. This makes it easy to peel cleanly from most surfaces including glass and plastic. A great choice for use in laboratory settings.



Stock No.	Description
GHS1299	1" Hazard Class Variety Pack (1,120 assorted labels per pad)
GHS1300	½" Hazard Class Variety Pack (1,820 assorted labels per pad)

Signal Word Signs

Signal Words are an important part of hazard identification in the GHS. These highly visible Signal Word placards are designed to be used with our GHS Pictograms.

Available in 6.25" x 15.75" and printed on outdoor grade adhesive VynMark using durable fade resistant inks. They come with a back split liner for easy application and are sold individually or in packages of 100.



GHS1275



GHS1276

Safety Data Sheet

Pocket Booklet

Our SDS Pocket Booklet is designed as a quick reference guide to the new style Safety Data Sheets (SDS) under GHS. This booklet provides an alphabetical list of terms and definitions for all the relevant GHS terminology, sections of the SDS, GHS symbols as well as a table breakdown of Acute Toxicity Classes. The booklet also provides a full color index of GHS hazard symbols and their meanings. The back of the book also has a small section for any additional notes to be entered. Designed to fit easily in a shirt pocket or desk-top for easy reference.

The booklets are 3-5/8" x 4-7/8" and sold 10/pkg (English edition - 42 pages).



Stock No.	Description
GHS2007	SDS Pocket Booklet
Stock No.	WHMIS 2015 (Canada) Description
GHS2008	WHMIS 2015 SDS Pocket Booklet - French

Pictogram Reference

Wallet Cards

Our GHS Wallets Cards are a quick and easy reference to the new GHS pictograms and their meanings. One side of the card provides the complete set of GHS pictograms with a detailed description of each. The other side contains the list of information required to be found on an SDS (Safety Data Sheet) as well as the images of the various Precautionary Statement Pictograms.

Printed in full color to match the look of the GHS system requirements. Each card is 4-1/4" x 2-1/2" with rounded corners. Covered in a heavy lamination on both sides to provide long term durability in pockets or wallet. Sold in packages of 50.



Stock No.	Description
GHS1015	Wallet Cards - (50/pkg)
Stock No.	WHMIS 2015 (Canada) Description
GHS1017	WHMIS 2015 Wallet Cards - French (50/pkg)

Make Your Own Laser Labels

Our laser printer templates make it easy for you to make your own labels for the new GHS requirements. These laser printer ready paper sheets come with a pre-printed red border and pre-cut labels. Use any desktop publishing package to quickly make your own professional looking labels.

Made from laser printable paper with permanent peel and stick backing. If color printing is not an option, use our Hazard Class and Personal Protective Equipment labels (sold separately) to complete your labels. Laser labels are sold in packages of 100 sheets.

Stock No.	Description
GHS1277LP	8.5" x 14" (1 per/sheet)
GHS1278LP	8.5" x 11" (1 per/sheet)
GHS1279LP	8.5" x 5.5" (2 per/sheet)
GHS1280LP	4.25" x 5.5" (4 per/sheet)
GHS1281LP	2.83" x 2.75" (12 per/sheet)

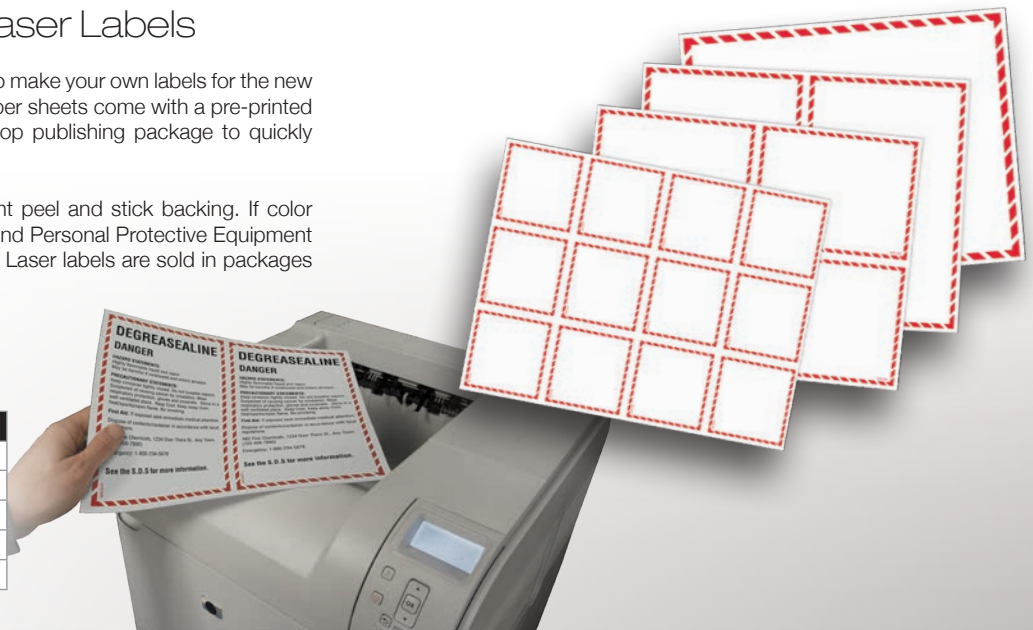

Make Your Own Thermal Transfer Labels

Need an open format label for your GHS requirements? Try our generic GHS label system. Labels are Thermal Transfer paper with a permanent adhesive and can be hand printed or used in any standard Thermal Transfer printer.

Use any standard desktop publishing package to quickly make your own Professional looking labels. Enhance the label with our Hazard Class and Personal Protective Equipment labels (sold separately). Labels sold by the roll.

Stock No.	Description
GHS1204	4" X 2" (1000/roll)
GHS1205	4" X 6" (500/roll)
GHS1206	6" X 7.125" (250/roll)
GHS1207	8" X 8" (250/roll)



Supplier Laser Labels

These open format labels are perfect for creating supplier labels for larger packaging formats. The paper labels are ideal for any indoor application and the more durable adhesive VynMark labels will work in outdoor applications.

All labels are manufactured on laser printable stock with a peel and stick adhesive back for permanent application. Labels come in both 8.5" x 11" and 8.5" x 14" size. Sold in bundles of 100 labels.



GHS1298LP - 8.5" x 11" Adhesive Paper
GHS1298VY - 8.5" x 11" Adhesive VynMark



GHS1278LP - 8.5" x 11" Adhesive Paper
GHS1278VY - 8.5" x 11" Adhesive VynMark

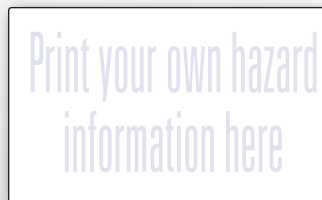

GHS1297LP - 8.5" x 14" Adhesive Paper
GHS1297VY - 8.5" x 14" Adhesive VynMark



GHS1277LP - 8.5" x 14" Adhesive Paper
GHS1277VY - 8.5" x 14" Adhesive VynMark

Store Displays

An excellent way to keep our industrial products within easy reach of your customers

Individual packs display well on pegboard hooks or simply sitting on a shelf. These products have many uses around the home, workshop, recreational, farm or vehicles.



RE3952

Black Anti-Slip Tape

UPC 0 57003 71097 9
 Size 4" x 15 ft
 Inner 1 roll
 Master 6 packs



RE3864

Yellow/Black Anti-Slip Tape

UPC 0 57003 83439 2
 Size 2" x 15 ft
 Inner 1 roll
 Master 12 packs



RE3950

Black Anti-Slip Tape

UPC 0 57003 70897 6
Size 1" x 15 ft
Inner 1 roll
Master 12 packs



RE3951

Black Anti-Slip Tape

UPC 0 57003 70997 3
Size 2" x 15 ft
Inner 1 roll
Master 12 packs



RE629BL

Black Anti-Slip Strip

UPC 0 57003 23897 8
Size 6" x 21"
Inner 1 strip
Master 8 packs



RE2110 DOT-C2 Red/Silver Reflective Tape

UPC 0 57003 13649 6
Size 2" x 10 ft
Inner 1 roll
Master 6 packs



RE2125 DOT-C2 Red/Silver Reflective Tape

UPC 0 57003 20596 3
Size 2" x 25 ft
Inner 1 roll
Master 6 packs

Safety Identification Display Merchandiser

Safety Sign Display

Improve your safety identification sales with our new safety products display rack. These units are able to accommodate safety signs, placards and safety tape products. This attractive display rack shows your customers the exciting and value added products that you can offer to them and help with their workplace safety compliance issues.

Merchandisers are available FREE when ordered full with product, offering you a no charge way to improve sales. Made from a durable powder coated steel, these racks will offer years of service. Speak to our sales staff for more information on how to order your merchandiser.



SRD200

Dimensions: 34" W, 68" H, 22" D

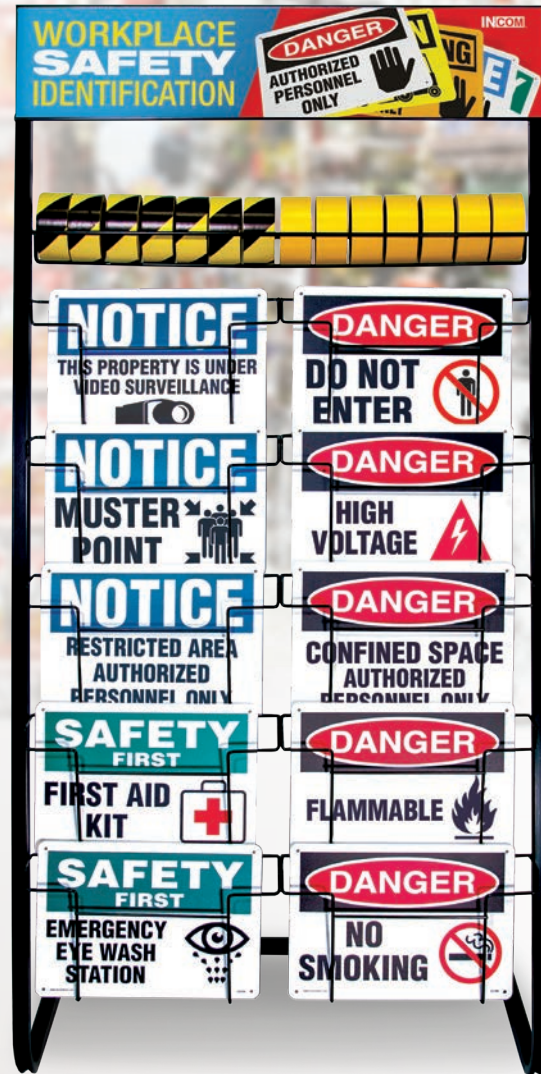

SRD100

Dimensions: 34" W, 68" H, 22" D



Custom Merchandisers

Pick and choose which items you would like in your display to meet the needs of your local market.

California Regulatory Warning
 **WARNING: Cancer and Reproductive Harm -**
www.P65Warnings.ca.gov

Safety Identification Display Merchandiser

DOT/TDG Placard Display

Improve your safety identification sales with our new safety products display rack. These units are able to accommodate safety signs, placards and safety tape products. This attractive display rack shows your customers the exciting and value added products that you can offer to them and help with their workplace safety compliance issues.

Merchandisers are available FREE when ordered full with product, offering you a no charge way to improve sales. Made from a durable powder coated steel, these racks will offer years of service. Speak to our sales staff for more information on how to order your merchandiser.



SRD300

Dimensions: 34" W, 68" H, 22" D



PDR100

Dimensions: 34" W, 68" H, 22" D



Custom Merchandisers

Pick and choose which items you would like in your display to meet the needs of your local market.

Top 10 OSHA Safety Signs

Effectively communicate important safety messages to employees and visitors

These safety signs are the most used in the workplace to indicate dangers, hazards and precautions. All the signs below are 10" x 14" and are coated with Sign Armor weather, chemical, abrasion and graffiti resistant coating.



No. 1

Stock No.	10" x 14"	Qty
SS1111V	Adhesive VynMark	
SS1111P	Semi-Rigid Plastic	
SS1111A	Aluminum	



No. 6

Stock No.	10" x 14"	Qty
SS1090V	Adhesive VynMark	
SS1090P	Semi-Rigid Plastic	
SS1090A	Aluminum	



No. 2

Stock No.	10" x 14"	Qty
SS1016V	Adhesive VynMark	
SS1016P	Semi-Rigid Plastic	
SS1016A	Aluminum	



No. 7

Stock No.	10" x 14"	Qty
SS4058V	Adhesive VynMark	
SS4058P	Semi-Rigid Plastic	
SS4058A	Aluminum	



No. 3

Stock No.	10" x 14"	Qty
SS1066V	Adhesive VynMark	
SS1066P	Semi-Rigid Plastic	
SS1066A	Aluminum	



No. 8

Stock No.	10" x 14"	Qty
SS4049V	Adhesive VynMark	
SS4049P	Semi-Rigid Plastic	
SS4049A	Aluminum	



No. 4

Stock No.	10" x 14"	Qty
SS1006V	Adhesive VynMark	
SS1006P	Semi-Rigid Plastic	
SS1006A	Aluminum	



No. 9

Stock No.	10" x 14"	Qty
SS2005V	Adhesive VynMark	
SS2005P	Semi-Rigid Plastic	
SS2005A	Aluminum	



No. 5

Stock No.	10" x 14"	Qty
SS1005V	Adhesive VynMark	
SS1005P	Semi-Rigid Plastic	
SS1005A	Aluminum	



No. 10

Stock No.	10" x 14"	Qty
SS2002V	Adhesive VynMark	
SS2002P	Semi-Rigid Plastic	
SS2002A	Aluminum	

Signage Audit Tool

Department: _____

Conducted by: _____

Date: _____

Purpose: Use this audit tool to assess the signage requirements for each Department and determine if the required signs are missing.

Is there clear and proper signage for restricted access locations?	Yes	No
Is there clear and proper signage for all emergency exits?	Yes	No
Is there clear and proper signage for the first-aid box?	Yes	No
Is there clear and proper signage for emergency shower and eye wash stations?	Yes	No
Is the fire fighting equipment correctly identified and signed?	Yes	No
Is there adequate signage for fire blankets?	Yes	No
Does each fire extinguisher have a fire extinguisher sign?	Yes	No
If so, is the sign 2 meters above the ground?	Yes	No
Is there a sign immediately above each extinguisher denoting type of fires it can safely be used on?	Yes	No
List all PPE required in this Department: Comments:		
Is there signage outlining all PPE requirements? If no, what PPE signage is missing?	Yes	No
Comments:		
Are there identified hazards that require appropriate signage? (refer to SOP's, injury statistics) eg. Danger signs, Caution signs Comments:		
Are there dangerous goods? If so, do they have clear and appropriate signage?	Yes	No
Are there any confined spaces? If so, do they have clear and appropriate signage?	Yes	No
Are there any damaged signs that require replacements?	Yes	No
Comments:		
Are there any hand written or makeshift signs that need replacing?	Yes	No
Comments:		

Has the Supervisor been advised of the signage requirements? Yes No

Name of Supervisor: _____ Date Advised: _____

