



TOOL, EQUIPMENT & SAFETY CATALOGUE 2016





SureWerx™

We've been your proud
CANADIAN PARTNER
for over 100 years

Designed to be the **BEST TOOLS
AND SAFETY EQUIPMENT**
so you can work with confidence



STRONGARM



sellstrom

**RIGOROUSLY
TESTED** to meet all
industry standards

Available from our warehouses and
distribution partners across Canada,
we are **EVERYWHERE**
YOU NEED US TO BE

Engineered with the
Canadian professional
worker's **SAFETY**
in mind

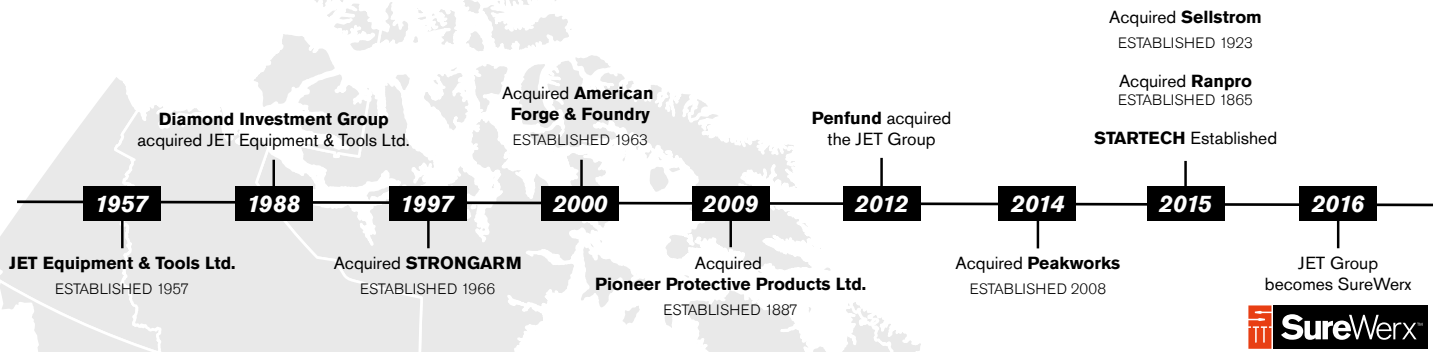

ABOUT SureWerx

We are passionate about the safety and productivity of professional workers in Canada. These are the men and women who build our country and, for over 100 years, our brands have been their partners on the jobsite.

Supplying only professional grade tools, equipment and safety gear, we have earned the trust of Canadian workers. Our products give you the peace of mind and confidence to take on any job.

Driven to engineer the best tool, equipment and safety solutions, our products perform in Canada's toughest working conditions. Before any product reaches you, it goes through a rigorous quality assurance program and independent testing to meet all industry standards.

We stand behind our products with leading warranty programs, replacement parts and a network of service centres to **GET YOU BACK TO THE JOB QUICKLY.**

WHAT DRIVES US

EVERYWHERE YOU NEED US TO BE

You can find our products listed online and stocked in our partner distributor locations, across Canada from Victoria, BC to St. John's, NL.

Our products and services are your single source for safety and productivity.







JET HAND TOOLS

PG. 6

JET ABRASIVES

PG. 345

JET AIR TOOLS

PG. 464

JET MATERIAL HANDLING

PG. 553

**JET INDUSTRIAL
POWER EQUIPMENT**

PG. 592

**STRONGARM
LIFTING AND HYDRAULIC EQUIPMENT**

PG. 614

STARTECH LIGHTING

PG. 665

ITC TOOLS AND EQUIPMENT

PG. 676

**PIONEER / RANPRO
SAFETY PRODUCTS**

PG. 715

**PEAKWORKS
FALL PROTECTION**

PG. 858

**SELLSTROM
PERSONAL PROTECTIVE EQUIPMENT**

PG. 895

MERCHANDISERS & INDEX

PG. 898





SAFETY AND PRODUCTIVITY

DESIGN

With features like offset and ergonomic handles to low swing arc ratchets to maximize your productivity

QUALITY

From chrome vanadium steel to hardened teeth and cutting edges to shatter-resistant handles, we use only the best materials

STANDARDS

Our tools meet or exceed international standards to ensure you get the job done right the first time

HAND TOOLS

DID YOU KNOW?

Many of our products are clearly labeled and colour coded to ensure you use the right product for the right application



TABLE OF CONTENTS

Table of Contents	8-9	Icon Legend	10
-------------------	-----	-------------	----

Tool Storage and Organizers 11

Portable Tool Boxes	12	Open Front Tool Chests	28
Chests and Roller Cabinets	13-21	Service Carts	30-31
Job Site Tool Storage	21	Shop Carts	32
Tool Bags	22-25	Workbenches	33
Chests and Roller Cabinets	26-27	Tool Organizers	34-36

Ratchet Wrenches 37

1/4", 3/8" & 1/2" Drive	38-42	3/4" & 1" Drive	43-44
-------------------------	-------	-----------------	-------

Chrome Sockets 45

Socket Wrench Sets		<i>TORX®</i> Bits	
1/4" Drive	46-47	External <i>Torx®</i>	63
3/8" Drive	48-49	3/8" Drive Spark Plug Sockets	64
1/2" Drive	50-51	Open Stock	
3/4" Drive	52	SAE	64-65
1" Drive	53	Metric	66-67
Sockets Sets		SAE Hex Bits	68
1/4" Drive	54	Metric Hex Bits	69
3/8" Drive	55-56	<i>TORX®</i> Bits	70
1/2" Drive	57-58	External <i>TORX®</i>	70
3/4" Drive	59	Socket Accessories	71-76
Hex Bits	60-61	Extension bars	74-76

Impact Sockets 77

Sockets Sets		1/2" Drive <i>TORX®</i> Bit	88
3/8" Drive	78	1/2" Drive Hex Bit	88
1/2" Drive	79-81	3/4" Drive Hex Bit	89
1/2" Drive Universal	82	3/8" & 1/2" Drive External <i>TORX®</i>	89
Mag Wheel Sockets	82	Socket Accessories	90-91
Torque Limiting Extensions	83	Open Stock	
3/4" Drive	84-85	SAE	92
1" Drive	85-86	Metric	93
1" Drive Truck Tire	87	Hex & <i>TORX®</i> Bits	94

Wrenches 95

Combination Wrenches		Ratchet Wrenches - Multi-fit	106
Raised Panel	96-97	Flare Nut Wrenches	107
Fully Polished	98-99	Crowfoot Wrenches	107
Multi-Fit	100	Adjustable Wrenches	108-109
Stubby Polished	101	Striking Wrenches	110
Ratchet Wrench Sets	102-104	Structural Wrenches	111
Ratchet Wrenches Open Stock	105	Adjustable Spanner Wrenches	112

Hex Key Wrenches 113

Hex Key Wrenches		Open Stock	
Folding Sets	114	Hex Key Wrenches	119-120
Sets	114-118	<i>TORX®</i> Key Wrenches	120

Torque Wrenches 121

Torque Wrenches	122-124	Torque Multipliers	126
Digital Torque Wrenches	125		

Screwdrivers 127

Jumbo Handle Series		Cushion Grip Screwdrivers	
Sets	128	Sets	134
Open Stock	129	Open Stock	135
Torque Drive® Series		Cushion Grip Multi-Bit Driver Sets	
Sets	130	Multi-Bit Driver Set	136
Open Stock	131	Ratcheting Drivers	137-139
Ergonomic Screwdrivers			
Sets	132		
Open Stock	133		

Screwdriver Bits 140

Insert Bits	140	Nutsetters	141
Power Bits	141		

Nut, Precision and Impact Drivers 142

Cushion Grip Nut Drivers		Jumbo Handle Series	
Sets	142	Sets	143
Open Stock	142	Open Stock	143
		Precision Screwdriver Sets	144
		Impact driver	144

Pliers and Cutters 145

Locking Pliers		Long Reach Series	151
Sets	146	Chrome Vanadium - Open Stock	152
Open Stock	146-148	Chrome Nickel	
Snap Ring Pliers		Sets	153
Sets	149	Open Stock	154-155
Open Stock	149	Shears	156-157
Chrome Vanadium		Wire Strippers and Cutters	158
Sets	150	Utility Knives	159-161
Open Stock	151	Cutting Tools Replacements	162

Sheet Metal Tools 163

Aviation Snips	163-164	Rivet Tools	165
----------------	---------	-------------	-----

VDE Tools 167

VDE Tool Kits	168-169	VDE Nut Drivers	
VDE Screwdrivers		Open Stock	171
Open Stock	170	VDE Pliers and Cutters	
		Open Stock	171

Pipe Tools 173

Pipe Wrenches	174-175	Deburring Tools	178
Tube Cutters	176-177	Ratcheting PVC Pipe Cutter	178
Pipe Cutter	177	Flaring Tools	179-180
Tube Bender	177		

Striking Tools 181

Hammers		Welding Hammer	189
Nailing Hammers	182-183	Axes and Mauls	189
Ball Pein Hammers	184-185	Soft Face Dead Blow Hammers	190-191
Club Hammer	185	Punch and Chisel	
Indestructible Handle Hammers	186-187	Sets	192-193
Sledge Hammers	188	Open Stock	194-196
Drilling Hammers	188	Stamps - Number / Letter	197
Rubber Mallets	189		

Construction Tools 199

Bars - Powerclaw™ Series	200-202	Staplers and Tackers	209-210
Bolt & Rod Cutters	203-204	Hacksaw Frames	211
Measuring Tools	205-208		

Shop Equipment 213

Clamping		Shop Equipment	
C-Clamps	214-15	Vises	219-221
L-Clamps	216-217	Pallet Truck	222
Pipe Clamps	218	Scissor Lift Hand Cart	223
Spring Hand Clamps	218	Parts Washers	224
		Creepers	225
		Roller seats	226
		Anti-Fatigue Mats	227

Metal Working Machinery 229

Bench grinders.....	230	Drill Presses.....	231-233
Optional Accessories.....	230	Metal Cutting Bandsaws.....	234-235

Gear Pullers 237

Specialty Pullers.....	238-239	Bearing Separators.....	239
------------------------	---------	-------------------------	-----

Lubrication / Fluid Transfer 241

Grease Guns.....	242-244	Grease Pump Accessories.....	251
Grease Gun Hoses.....	245	Water, Chemical and Oil Pumps.....	252-253
Quick Change Coupler Adapters.....	246	Oil and Fuel Pumps.....	253-255
Grease Gun Couplers.....	247	Fuel and Gasoline Pumps.....	256-257
Grease Gun Holders.....	247	Oil Drains.....	258-259
Grease Fittings.....	248-249	Drum Handling.....	260
Grease Pumps.....	250		

Specialty Automotive 261

Brake Service

Brake Repair Tools.....	262	Flaring Tool Kits.....	264-265
Tube Benders & Cutters.....	263	Brake Repair Tools.....	265

Hones

Cylinder Hones - Abrasive.....	266
--------------------------------	-----

Bearing and Bushing Tools

Bearing Packers.....	267	Truck Wheel Bearing Locknut Sockets.....	268
Front Wheel Drive Axle Nut Tools.....	268		

Suspension/Drive Train Repair

Four Wheel Drive Spindle Locknut Tools.....	269-270	Front End Service Tools.....	270-273
---------------------------------------------	---------	------------------------------	---------

Cooling System

Hose and Clamp Tools.....	274-275	Fan Clutch Wrenches.....	276
Drive Belt Tools.....	275		

Engine System

Compression and Pressure Testers.....	277-280	Valve Lapping Tools.....	282
Piston Ring Tools.....	281	Tune-Up Tools.....	282
Head and Valve Repair.....	281		

Exhaust

Exhaust Tools.....	283	Pressure Testers.....	283
--------------------	-----	-----------------------	-----

Fuel/Injection System

Fluid Line Tools.....	284-285	Pressure Testers.....	286
-----------------------	---------	-----------------------	-----

Sensor and Sender Units

Open Stock Sockets.....	287
-------------------------	-----

Hand Tools

Blow Guns.....	288	Hand Brush.....	292
Pullers and Puller Kits.....	288-290	Scrapers.....	293
Gear Pullers.....	291	Seal Puller.....	293
Bearing Separators.....	291	Feeler Gauges.....	294
Gear Pullers.....	292		

Oil Filter/Drain Plug Tools

Oil Filter Wrenches.....	295-296
--------------------------	---------

Fastener Tools

Driver Bits And Sockets.....	297	Screwdrivers.....	298
Stud, Bolt And Nut Removal.....	297	Screw Extractors.....	298
Punches - Brass.....	297	Taps, Dies and Thread Repair.....	299
Pliers.....	297		

Battery Service

Post and Terminal Service.....	300	Testing Equipment.....	301
Battery Carrier.....	300		

Electrical System

Electric Testers.....	302, 305	Spark Plug/Ignition Tools.....	303-304
-----------------------	----------	--------------------------------	---------

Specialty Automotive 261

Miscellaneous and Magnetic Pick-Up Tools

Miscellaneous.....	306	Magnetic Pick-Up Tools.....	306
--------------------	-----	-----------------------------	-----

Tire Service

Tire Pressure Gauges.....	307-308	Air Inflator Gauges.....	310
Tire Valve Tools.....	309	Air Chucks.....	310
Pliers for Wheel Weights.....	309		

Upholstery/Trim Panel Tools

Upholstery Tools.....	311
-----------------------	-----

Automotive Gauges

Chrome Series - Professional Duty.....	312	Tachometers.....	314
Chrome Series - Heavy Duty and Marine.....	313	Electric Fuel Level Gauge Kit.....	314
Easy-Read Gauge Kits White Face.....	313	HTA Series Replacement Parts.....	314

Precision Measuring Tools 315

Calipers.....	316	Micrometers.....	318
Indicators.....	317	Gauge.....	319
Magnetic Bases.....	317	Brake and Rotor Tools.....	320

Electronic Measuring Tools 321

Thermometers.....	321	Meters - Digital.....	323
Multimeters - Digital.....	322		

Mechanics Tools 325

Chisel Point Scrapers.....	326	Pry Bars.....	328-330
Pick, Hook and Scraper Tools.....	327		

Master Tool Kits 331

549 Piece Master Tool Kit.....	332-334	211 Piece Mechanic's Starter Tool Kit.....	337-338
306 Piece Intermediate Tool Kit.....	335-337	131 Piece Utility Tool Kit.....	339

Replacement Parts 340

Replacement Parts.....	340	Cushion Grip Multi-Bit Drivers.....	
Ratchets.....	340-341	Replacement Bits.....	343
Torque Wrenches.....	342	Multi-Bit Drivers Replacement Bits.....	343
Pipe Wrenches.....	342		

Warranty 344

Warranty Information.....	344
---------------------------	-----



ICON LEGEND

6 Point		Slotted Screwdriver		Warning Note	
12 Point		Slotted Screwdriver Square Shank		Made in Canada	
A2 Steel		Phillips Screwdriver		Made in USA	
S2 Steel		Square Screwdriver		Ball Bearing Slides	
Includes Case		Hex Screwdriver		New	
Includes Pouch		Torx® Screwdriver		JET Exclusive	
Chrome Molybdenum		Hex Key Head		Super Heavy Duty	
Chrome Nickel		Nut Driver			
Chrome Vanadium		Torx® Socket Head			
Use Eye Protection		External Torx®			





TOOL STORAGE & ORGANIZERS





PORTABLE TOOL BOXES

Plastic

- Extra thick walls stand up to heavy loads
- Resists scratches and dents, won't rust
- Removable tool tray
- Steel hinge pins for long service life
- 19" and 22" models feature bolt-through carrying handles for extra heavy loads
- Recessed handle for easy storage and transport
- V-groove on lid holds small parts
- Twin heavy duty buckles distribute weight evenly
- Can be padlocked for security

PROD. NO.	MOD. NO.	Width	Depth	Height	Tray Size
842142	JPTB-16	16"	8"	7-1/2"	13-1/2 x 5"
842143	JPTB-19	19"	9"	8"	16-1/4 x 6"
842144	JPTB-22	22"	10-1/4"	9-1/2"	19 x 7-1/4"

Stainless Steel/Plastic - Heavy Duty

- Combination of stainless steel and plastic components offers great strength with low weight
- Will not rust
- Removable tool tray
- Steel hinge pins for long service life
- Recessed handle for easy storage and transport
- Twin heavy duty steel buckles distribute weight evenly
- Can be padlocked for security

PROD. NO.	MOD. NO.	Width	Depth	Height	Tray Size
842152	JPSTB-15	15"	6-1/4"	7"	13-1/2" x 4-1/2"
842153	JPSTB-20	20"	9-5/8"	8-7/8"	18" x 6-1/2"
842154	JPSTB-22	22-1/2"	11"	10-3/4"	21" x 8"

Metal - Heavy Duty

- Heavy gauge powder coated steel for durability
- Rust resistant plated buckles
- Padlock or key lock

PROD. NO.	MOD. NO.	Width	Depth	Height	Overall Weight
842104	TB21	21"	8-3/4"	9"	11 lb
842105	TB26	26"	8-3/4"	9"	14 lb
842124	TB21-3	21"	8-3/4"	12"	23 lb
842134	CTB21-4	21-1/4"	8-3/4"	12"	16 lb

CHESTS AND ROLLER CABINETS

SUMO® Series



- SUMO® Series tool storage for professional applications
- Double wall steel construction with reinforced bottom channel on cabinets
- Ball bearing slides on all drawers
- Extruded aluminum drawer pulls
- Heavy duty casters
- Larger chests complete with gas struts for easy opening (42" and 56" only)
- All models complete with drawer liners

SUMO® Series Mechanics Chest - 27" x 18" 6 Drawers 842553 / SMC2706

	Width	Depth	Height	Overall Weight
OVERALL	26"	17-7/8"	18-5/16"	38 lb
6 DRAWERS	23"	16"	2"	

Maximum Load Per Drawer: 75 lb

SUMO® Series Roller Cabinet - 27" x 18" 7 Drawers 842503 / SRC2707

	Width	Depth	Height	Overall Weight	Wheels
OVERALL	27"	18-3/4"	35-5/8"	97 lb	5" x 1-1/4"
4 DRAWERS	23"	16"	2"		2 swivel
2 DRAWERS	23"	16"	4-1/4"		2 rigid
1 DRAWER	23"	16"	6-7/16"		

Maximum Load Per Drawer: 75 lb

SUMO®



842503





CHESTS AND ROLLER CABINETS

SUMO® Series



842563



842513

SUMO®

842573



842523



Mechanics Chest - 42" x 16" 10 Drawers

842563 / SMC4210

	Width	Depth	Height	Overall Weight
OVERALL	40-7/8"	16"	19-1/4"	121 lb
3 DRAWERS	22-1/2"	14"	1-3/4"	
2 DRAWERS	22-1/2"	14"	3-3/4"	
3 DRAWERS	12-1/8"	14"	1-3/4"	
2 DRAWERS	12-1/8"	14"	3-3/4"	

Maximum Load Per Drawer: 100 lb

Roller Cabinet - 42" x 18" 11 Drawers

842513 / SRC4211

	Width	Depth	Height	Overall Weight	Wheels
OVERALL	41-1/2"	18"	39-7/8"	197 lb	5" x 2"
5 DRAWERS	21-7/8"	15"	2-1/4"		2 swivel
1 DRAWER	21-7/8"	15"	4-7/8"		2 rigid
1 DRAWER	36-1/2"	15"	3-7/8"		
2 DRAWERS	12"	15"	2-1/4"		
1 DRAWER	12"	15"	4-7/8"		
1 DRAWER	12"	15"	7-1/2"		

Maximum Load Per Drawer: 100 lb

Mechanics Chest - 56" x 24" 6 Drawers

842573 / SMC5606

	Width	Depth	Height	Overall Weight
OVERALL	55-1/2"	23-7/8"	19-1/8"	225 lb
2 DRAWERS	34-5/8"	21-7/8"	4-1/2"	
2 DRAWERS	34-5/8"	21-7/8"	1-5/8"	
1 DRAWER	15-3/8"	21-7/8"	3-5/8"	
1 DRAWER	15-3/8"	21-7/8"	8-3/4"	

Maximum Load Per Drawer: 100 lb

Roller Cabinet - 56" x 24" 10 Drawers

842523 / SRC5610

	Width	Depth	Height	Overall Weight	Wheels
OVERALL	56-3/8"	24"	39-1/2"	359 lb	5" x 2"
1 DRAWER	51-3/8"	20-15/16"	3-1/2"		4 swivel
2 DRAWERS	34-1/8"	20-15/16"	1-11/16"		2 rigid
2 DRAWERS	34-1/8"	20-15/16"	3-5/8"		
1 DRAWER	34-1/8"	20-15/16"	4-1/4"		
3 DRAWERS	15"	20-15/16"	1-11/16"		
1 DRAWER	15"	20-15/16"	11-1/8"		

Maximum Load Per Drawer: 100 lb

CHESTS AND ROLLER CABINETS

SUMO® Series Side Lockers



- Tall side lockers offer storage for larger tools too high for regular drawers
- Full height design for use with cabinet and chest combinations
- Both lockers include 2 adjustable shelves
- 42" series locker includes one roller bearing drawer

SUMO®

42" Side Locker 842542 / SL4202

	Width	Depth	Height	Overall Weight
OVERALL	15-1/2"	18-1/4"	52"	72 lb
2 SHELVES	15-1/8"	16-3/4"	3/4"	
1 DRAWER	11-1/8"	15-1/4"	2-3/8"	

Side locker for SRC4211 (842513)



Designed for use with SUMO® Tool Storage units only



Storage drawer

56" Side Locker 842543 / SL5602

	Width	Depth	Height	Overall Weight
OVERALL	15-1/2"	24"	51"	66 lb
2 SHELVES	14-7/8"	22-3/8"	5/8"	

Side locker for SRC5610 (842523)



842542





CHESTS AND ROLLER CABINETS

Black & Gold Series Mechanic's Chests



- Ball bearing slides on all drawers
- Extra heavy gauge steel construction
- Double walls for maximum strength and weight capacity
- Reinforced base and heavy duty casters on all roller cabinets
- Tool tray included with every 27" top chest
- Nickel plated gold look side handles
- Anti-slip drawer liners
- Protective top mat on roller cabinets
- Push-Lock safety drawers stay closed when moving

26" x 12" 6 Drawers

842652 / MC2606-BG

	Width	Depth	Height	Overall Weight
OVERALL	26"	12"	14-1/2"	49.5 lb
3 DRAWERS	6-3/4"	10-7/16"	1-7/8"	
2 DRAWERS	22-5/8"	10-7/16"	1-7/8"	
1 DRAWER	22-5/8"	10-7/16"	2-7/16"	

Maximum Load Per Drawer: 75 lb



26" x 12" 9 Drawers

842654 / MC2609-BG

	Width	Depth	Height	Overall Weight
OVERALL	26"	12"	16-1/2"	57 lb
6 DRAWERS	6-3/4"	10-7/16"	1-7/8"	
2 DRAWERS	22-5/8"	10-7/16"	1-7/8"	
1 DRAWER	22-5/8"	10-7/16"	2-7/16"	

Maximum Load Per Drawer: 75 lb



26" x 16" 6 Drawers

842653 / MC2606D-BG

	Width	Depth	Height	Overall Weight
OVERALL	26"	15-7/8"	18-3/4"	72.4 lb
5 DRAWERS	22-1/2"	14-3/8"	1-7/8"	
1 DRAWER	22-1/2"	14-3/8"	2-3/8"	

Maximum Load Per Drawer: 75 lb



CHESTS AND ROLLER CABINETS

Black & Gold Series Roller Cabinets



27" x 18" 5 Drawers **842602** / RC2705-BG

	Width	Depth	Height	Overall Weight	Wheels
OVERALL	27"	18-5/16"	31-5/16"	90 lb	5"
3 DRAWERS	23"	14-7/8"	2-7/8"		2 swivel
2 DRAWERS	23"	14-7/8"	6"		2 rigid

Maximum Load Per Drawer 75 lb



27" x 18" 7 Drawers **842604** / RC2707-BG

	Width	Depth	Height	Overall Weight	Wheels
OVERALL	27"	18-5/16"	37-5/8"	110 lb	5"
5 DRAWERS	23"	14-7/8"	2-7/8"		2 swivel
2 DRAWERS	23"	14-7/8"	6"		2 rigid

Maximum Load Per Drawer 75 lb





CHESTS AND ROLLER CABINETS

Black & Gold Series Mechanic's Chests



41" x 18" 14 Drawers

842663 / MC4114-BG

	Width	Depth	Height	Overall Weight
OVERALL	40-5/16"	16"	19-1/8"	137 lb
9 DRAWERS	6-3/4"	14-1/8"	1-7/8"	
2 DRAWERS	22-5/8"	14-1/8"	1-7/8"	
1 DRAWER	22-5/8"	14-1/8"	2-7/16"	
2 DRAWERS	12-3/16"	14-1/8"	5-1/2"	

Maximum Load Per Drawer 100 lb



56" x 24" 9 Drawers

842673 / MC5609-BG

	Width	Depth	Height	Overall Weight
OVERALL	55-1/2"	23-7/8"	19-3/8"	225 lb
7 DRAWERS	25-1/8"	22"	1-7/8"	
1 DRAWER	25-1/8"	22"	4-1/2"	
1 DRAWER	25-1/8"	22"	6-1/2"	

Maximum Load Per Drawer 100 lb



842613-63



842623-73



CHESTS AND ROLLER CABINETS

Black & Gold Series Roller Cabinets



41" x 18" 10 Drawers **842613** / RC4110-BG

	Width	Depth	Height	Overall Weight	Wheels
OVERALL	41-1/8"	18-3/8"	39-1/2"	217 lb	5"
7 DRAWERS	22"	15"	2-7/16"		2 swivel
1 DRAWER	22"	15"	4-7/8"		2 rigid
2 DRAWERS	15-7/8"	15"	2-7/16"		

Maximum Load Per Drawer 100 lb



41" x 18" 16 Drawers **842614** / RC4116-BG

	Width	Depth	Height	Overall Weight	Wheels
	41-1/8"	18-5/16"	39-5/8"	232 lb	5"
1 DRAWER	22"	15"	4-7/8"		2 swivel
1 DRAWER	12-1/4"	15"	4-7/8"		2 rigid
7 DRAWERS	22"	15"	2-7/16"		
7 DRAWERS	12-1/4"	15"	2-7/16"		

Maximum Load Per Drawer 100 lb



56" x 24" 13 Drawers **842623** / RC5613-BG

	Width	Depth	Height	Overall Weight	Wheels
OVERALL	56"	24"	39-1/2"	446 lb	5"
10 DRAWERS	24-1/2"	21-1/8"	2-7/16"		4 swivel
2 DRAWERS	24-1/2"	21-1/8"	5"		2 rigid
1 DRAWER	51-5/8"	21-1/8"	3-5/8"		

Maximum Load Per Drawer 100 lb





CHESTS AND ROLLER CABINETS

Pro Series Mechanic's Chests & Roller Cabinets

BEST

- Two piece friction slides provide long service life
- Full width drawer pulls for comfortable, easy operation
- Full width / full height double wall construction for superior rigidity
- Rear locking mechanism provides maximum security
- **Canadian built using the best quality domestic steel for maximum storage capacity without the risk of bending under heavy loads**

26" x 12" 6 Drawers

842252 / MC26-6

	Width	Depth	Height	Overall Weight
OVERALL	26"	12"	14-1/2"	55 lb
3 DRAWERS	7"	10-1/2"	2"	
2 DRAWERS	23"	10-1/2"	2"	
1 DRAWERS	23"	10-1/2"	2-1/2"	

Maximum Load Per Drawer 75 lb



26" x 18" 12 Drawers

842254 / MC26-12

	Width	Depth	Height	Overall Weight
OVERALL	26"	17-7/8"	20-1/2"	105 lb
9 DRAWERS	7"	16"	2"	
2 DRAWERS	23"	16"	2"	
1 DRAWER	23"	16"	4-1/4"	

Maximum Load Per Drawer 75 lb



27" x 18" 5 Drawers

842202 / RC27-5

	Width	Depth	Height	Overall Weight	Wheels
OVERALL	27"	18-3/4"	35-5/8"	109 lb	5" x 1-1/4"
4 DRAWERS	23"	16"	4-1/4"		2 swivel
1 DRAWER	23"	16"	6-7/16"		2 rigid

Maximum Load Per Drawer 75 lb



27" x 18" 11 Drawers

842204 / RC27-11

	Width	Depth	Height	Overall Weight	Wheels
OVERALL	27"	18-3/4"	42-3/8"	151 lb	5" x 2"
4 DRAWERS	11"	16"	2"		2 swivel
4 DRAWERS	23"	16"	2"		2 rigid
2 DRAWERS	23"	16"	4-1/4"		
1 DRAWER	23"	16"	8-1/2"		

Maximum Load Per Drawer 75 lb



CHESTS AND ROLLER CABINETS

Pro Series Truck Box



- Extra heavy gauge steel and additional spot welds designed to withstand the constant vibration and bumps of road travel
- Drop front cover with neoprene seal prevents water from entering
- Concealed hinges prevent rust
- Black powder coated paint for long term rust resistance
- Full extension friction drawer slides
- Heavy duty welded side handles with 90° stops
- Heavy duty rubber feet keep box out of water

26" x 18" 5 Drawers 842256 / TB26-5

	Width	Depth	Height	Overall Weight
OVERALL	26"	17-7/8"	23"	124 lb
3 DRAWERS	23"	16"	2"	
2 DRAWERS	23"	16"	4-1/4"	

Maximum Load Per Drawer 75 lb



JOBSITE TOOL STORAGE

Jobsite Tool Storage Box - Super Heavy Duty

- Super Heavy Duty 16 gauge steel body and lid for maximum security
- Robotically welded seams for increased strength
- Dual recessed lock housings prevent use of bolt cutters or blades to cut locks
- Staked and welded piano hinge prevents hinge pin from being driven out
- Overlapping lid prevents leaks and features full width reinforcing bolster for added strength
- Finger groove in lid for easy opening even with gloves
- Heavy duty lid prevents accidents
- 12 gauge 4-way skids allow forklift access from front, back, and both sides for increased transportation options
- Skids are predrilled to accept optional 6" x 2" heavy duty casters
- High visibility orange powder coat for superior corrosion resistance
- Made in Canada!

Jobsite Tool Box - 32" x 19" 842480 / JSB-3219

	Width	Depth	Height (without wheels)	Overall Weight
OVERALL	32-1/8"	19"	17-1/2"	70 lb

Shipping Weight: 72 lb

Jobsite Tool Box - 48" x 24" 842481 / JSB-4824

	Width	Depth	Height (without wheels)	Overall Weight
OVERALL	48-1/8"	24-1/8"	28-3/8"	136 lb

Shipping Weight: 140 lb



SITE SAFE



MADE IN CANADA





TOOL BAGS

- Premium quality 1680D polyester material for professional applications
- Reinforced with double stitching and steel rivets in all critical weight bearing areas for years of worry free use
- Chrome plated and stainless steel components resist corrosion
- Complete with padded shoulder strap for easy transport

16" Open Top Tool Bag

842001/ JOTB-16

- 5 exterior pockets and 18 interior pockets for organizing small tools
- Large interior space holds power tools and larger items
- Two hook and loop straps secure levels or other long tools to top of bag
- Double riveted stainless steel tube handle with PVC grip for comfort
- Removable cover protects tools from the elements
- Plastic skids on bottom keep fabric off the ground
- Includes 2 plastic organizer boxes
- Interior size 16" x 8" x 7"
- Overall size 20" x 10" x 10"

NEW



24" Open Top Tool Bag

842002/ JOTB-24

- 6 exterior pockets and 36 interior pockets for organizing small tools
- Large interior space holds power tools and larger items
- Two hook and loop straps secure levels or other long tools to top of bag
- Double riveted stainless steel tube handle with PVC grip for comfort
- Removable cover protects tools from the elements
- Plastic skids on bottom keep fabric off the ground
- Interior size 24" x 10" x 11"
- Overall size 24" x 12" x 12"

NEW



16" Zip Top Tool Bag

842006/ JZTB-16

- Self-repairing zipper keeps tools secure
- Steel reinforcement rods keep mouth of bag open for convenience
- 10 exterior pockets and 14 interior pockets for organizing tools
- 8 exterior tool holders for added storage
- Large interior space holds power tools and larger items
- Two straps secure levels or other long tools to side of bag
- Double stitched padded carrying handle
- Synthetic rubber bottom protects bag from water and chemicals
- Interior size 16" x 8" x 11"
- Overall size 16" x 9" x 12"

NEW

* Tools not included

TOOL BAGS

8" Square Tool Bag

842011/ JSTB-8

- 5 exterior pockets and 18 interior pockets for organizing small tools
- Large interior space holds power tools and larger items
- Plastic skids on bottom keep fabric off the ground
- Includes 1 plastic organizer box
- Overall size 8-1/2" x 8-1/2" x 9-1/2" (not including handle)

NEW

Tool Back Pack

842016/ JTBP-100

- Large main compartment features 22 pockets, 9 elastic loops, and 1 large zipper pocket for organizing tools
- Secondary compartment features 18 pockets for added capacity
- Outside of back pack features large zipper pocket, cell phone pocket, water bottle holder, and luggage tag holder
- Padded adjustable shoulder straps feature non-slip material to help keep pack from sliding down
- Thick padding on back of pack for user comfort
- Synthetic rubber feet protect pack from water and chemicals

NEW

**YOUR TOOLS
DESERVE TO BE
CARRIED
IN ONE OF THESE**



* Tools and bottle not included



TOOL BAGS

45 Pocket Bucket Organizer

842096/JBO-45

- 900 D polyester material for professional applications
- Double stitched for years of worry free use
- Turns any 5 gallon bucket into a heavy duty tool organizer
- Various sized pockets hold a wide variety of tools and equipment

NEW



56 Pocket Bucket Organizer

842097/JBO-56

- Premium quality 1680D polyester material for professional applications
- Double stitched for years of worry free use
- Turns any 5 gallon bucket into a heavy duty tool organizer
- Various sized pockets hold a wide variety of tools and equipment

NEW



** Bucket and tools not included*



2 Pouch Tool Belt

842091/JTB-2

- Premium quality 1680D polyester material for professional applications
- Double stitched for years of worry free use
- 2 pouches each feature 5 interior pockets, 2 exterior pockets, 3 tool holder loops, 1 nail pocket and one hammer loop
- Includes measuring tape holder
- Heavy duty padded belt with hook and loop closure
- Pouches suspended with separate web belt with quick release buckle

NEW



Tool Pouch

842092/JTP-1

- Premium quality 1680D polyester material for professional applications
- Double stitched for years of worry free use
- Pouch features 4 elastic tool holders in main pocket, 4 exterior pockets and 4 exterior tool holders
- Carabiner and tape strap with locking swivel hook
- Can be attached to any tool belt using sewn loop or steel clip

NEW



** Tools not included*





TREASURE SERIES



842704

842754

TOOL CHESTS AND ROLLER CABINETS

Treasure Series

BEST**

Unique styling stands out in any garage or shop! Drop down trays on chest and flip up trays on cabinet provide plenty of work space. Full width aluminum drawer pulls feature safe lock latches to prevent drawers opening when moving tool box.*

- Ball bearing drawer slides with auto close feature ensure drawers are completely closed before locking
- Safe-Lock system prevents drawers from accidentally opening when moving tool box*
- Recessed handles on both sides do not protrude outside of tool box dimensions – easy to park and move!
- Attractive automotive style casters
- All drawers complete with drawer liners
- 5/8" MDF work surface included with roller cabinets*
- Secure rear lock mechanism
- Sand finish powder coat paint resists scratches, chemicals, and fingerprints
- A JET Exclusive!

* Not available on 27" product

**JET
EXCLUSIVE**

Tool Chest 27" x 18" 7 Drawers

842754 / TMC2708

	Width	Depth	Height	Overall Weight
OVERALL	31-5/16"	18-7/8"	40"	159 lb
2 DRAWERS	22-3/8"	15-5/8"	2-7/8"	
5 DRAWERS	22-3/8"	15-5/8"	2-7/8"	

NEW

Maximum Load per Drawer 100 lb



Roller Cabinet 27" x 18" 8 Drawers

842704 / TRC2707

	Width	Depth	Height	Overall Weight
OVERALL	31-5/16"	18-7/8"	21-1/2"	107 lb
1 DRAWER	22-3/8"	15-5/8"	2-7/8"	
3 DRAWERS	6-5/8"	15-5/8"	2"	
4 DRAWERS	22-3/8"	15-5/8"	2"	

NEW

Maximum Load per Drawer 100 lb



TOOL CHESTS AND ROLLER CABINETS

Treasure Series



TREASURE SERIES

Tool Chest - 41" x 18" 8 Drawers

842762 / TMC4208

	Width	Depth	Height	Overall Weight
OVERALL	45-3/4"	18-15/16"	21-5/16"	138 lb
4 DRAWERS	22-7/16"	15-5/8"	2-15/16"	
4 DRAWERS	12-3/16"	15-5/8"	2-15/16"	
2 SHELVES				

Maximum Load per Drawer 100 lb



Roller Cabinet - 41" x 18" 11 Drawers

842712 / TRC4211

	Width	Depth	Height	Overall Weight
OVERALL	45-3/4"	18-15/16"	40-1/16"	259 lb
1 DRAWER	36-13/16"	15-5/8"	4-3/4"	
1 DRAWER	22-7/16"	15-5/8"	6-1/16"	
1 DRAWER	12-1/8"	15-5/8"	12-5/16"	
3 DRAWERS	12-1/8"	15-5/8"	2-5/16"	
5 DRAWERS	22-7/16"	15-5/8"	2-15/16"	
2 SHELVES				

Maximum Load per Drawer 100 lb



Tool Chest - 53" x 19" 8 Drawers

842772 / TSMC5308

	Width	Depth	Height	Overall Weight
OVERALL	52-13/16"	18-7/8"	21-1/4"	166 lb
4 DRAWERS	29-5/8"	15-5/8"	3"	
4 DRAWERS	12-1/8"	15-5/8"	3"	
2 SHELVES				

Maximum Load per Drawer 100 lb



Roller Cabinet - 53" x 19" 12 Drawers

842722 / TSRC5312

	Width	Depth	Height	Overall Weight
OVERALL	53"	19-3/32"	33-7/16"	297 lb
1 DRAWER *	44-1/16"	15-5/8"	4-3/4"	
1 DRAWER *	29-5/8"	15-5/8"	6"	
1 DRAWER *	12-1/8"	15-5/8"	9-1/8"	
4 DRAWERS	12-1/8"	15-5/8"	3"	
5 DRAWERS	29-5/8"	15-5/8"	3"	
2 SHELVES				

Maximum Load per Drawer 100 lb with single slides

* 200 lb with dual slides





842281



842286

OPEN FRONT TOOL CHESTS

- Open front design keeps tools organized and visible at a glance, reducing time wasted looking for tools
- All tools are held securely in place when lid is closed – ideal for use on service trucks or atop a roller cabinet or tool cart
- Extra heavy duty 16 gauge steel with fully welded seams for maximum strength
- No drawer slides to fail during transport even over the roughest roads
- Full weather stripping keeps tools dry and clean in outdoor environments
- Dedicated pegs and holes hold a wide variety of sockets, wrenches, extensions, and screwdrivers
- Additional storage compartments hold other miscellaneous tools
- Socket tray lifts to access tools stored underneath
- Strong two point lock with double sided key for security and convenience
- Gas shock raises lid
- Sturdy side handles for easy movement
- Powder coated for corrosion resistance
- Complete with compartment liners
- **TOOLS NOT INCLUDED**

26" - Super Heavy Duty

842281 / JOFC-26

	Width	Depth	Height	Overall Weight
OVERALL	26-1/4"	17-3/8"	18-3/8"	66 lb

Peg Qty. for 1/4" Dr Socket: **18**Peg Qty. for 1/4" Dr Deep Socket: **18**Peg Qty. for 3/8" Dr Socket: **13**Peg Qty. for 3/8" Dr Deep Socket: **13**Peg Qty. for 1/2" Dr Socket: **16**Peg Qty. for 1/2" Dr Deep Socket: **16**Peg Qty. for Wrenches: **17** (up to 3 per peg)

36" - Super Heavy Duty

842286 / JOFC-36

	Width	Depth	Height	Overall Weight
OVERALL	30-3/4"	15-1/4"	18-1/4"	66 lb

Peg Qty. for 1/4" Dr Socket: **32**Peg Qty. for 1/4" Dr Deep Socket: **32**Peg Qty. for 3/8" Dr Socket: **28**Peg Qty. for 3/8" Dr Deep Socket: **28**Peg Qty. for 1/2" Dr Socket: **39**Peg Qty. for 1/2" Dr Deep Socket: **40**Peg Qty. for Wrenches: **39** (up to 3 per peg)





SERVICE CARTS

4 Drawer Service Cart 30" x 16" - Heavy Duty

842911 / JTC-30164

- Heavy gauge steel shell for professional use
- Ball bearing slides rated for 75 lb/pair
- 4 drawers, large bottom shelf, and generous under-lid room provide ample storage
- Side tray folds out to provide workspace
- Separate locking screwdriver rack
- Rear drawer lock mechanism for added security
- Lid lays flat against back of cart
- 4 way swivel polyurethane casters
- Comfortable tube steel handle
- Complete with drawer liners



842911

	Width	Depth	Height	Overall Weight
OVERALL	35"	17"	32-3/4"	106 lb
2 DRAWERS	12-3/8"	14-1/2"	2"	
1 DRAWER	26-1/2"	14-1/2"	2"	
1 DRAWER	26-1/2"	14-1/2"	3-1/4"	
SHELF	30"	16"	3"	
UNDER LID	30"	16"	3"	
SIDE SHELF	14"	16"	1/2"	



BALL BEARING SLIDES

4 Drawer Service Cart 30" x 19" - Heavy Duty

842916 / JTC-30194

- Heavy gauge steel shell for professional use
- Ball bearing slides rated for 75 lb/pair
- 4 drawers, large bottom shelf, and generous under-lid room provide ample storage
- Drawer slides feature positive retainer system to prevent drawers opening while moving cart
- Long tool storage racks on both sides of cart are secured when lid is locked
- Full height plastic corner bumpers protect automobile finishes from scratches
- Automatic rear drawer lock mechanism engages when lid is closed
- Gas shocks automatically raise lid to open position and unlock all drawers
- 2 fixed and 2 swivel casters with chrome racing style wheels
- Comfortable TPR wrapped oval tube steel handle
- Complete with drawer liners



842916

	Width	Depth	Height	Overall Weight
OVERALL	35"	20-1/2"	40-1/2"	121 lb
2 DRAWERS	12-3/8"	14-1/2"	2"	
1 DRAWER	25-1/2"	17-1/2"	3"	
1 DRAWER	25-1/2"	17-1/2"	6-1/4"	
SHELF	30"	19"	3"	
UNDER LID	30"	19"	6"	



BALL BEARING SLIDES

4 Drawer Service Cart 33" x 18" - Heavy Duty

842921 / JTC-33184

- Heavy gauge steel shell for professional use
- Ball bearing slides rated for 50 lb/pair
- 4 drawers, large bottom shelf, and generous under-lid room provide ample storage
- Drawer slides feature positive retainer system to prevent drawers opening while moving cart
- Long tool storage racks on both sides of cart
- Rear drawer lock mechanism for added security
- Gas shocks support lid in open position
- Shocks can be disconnected allowing lid to lay flat against back of cart
- Stiffener plate strengthens lid and prevents warping
- 4 way swivel casters for maximum maneuverability
- Comfortable oval tube steel handle
- Complete with drawer liners

	Width	Depth	Height	Overall Weight
OVERALL	36-1/4"	18"	39-1/4"	93 lb
2 DRAWERS	13-1/2"	15-1/2"	2-1/4"	
1 DRAWER	28-1/4"	15-1/2"	2-1/4"	
1 DRAWER	28-1/4"	15-1/2"	3-1/4"	
SHELF	32-1/4"	17-1/2"	3"	
UNDER LID	32-1/4"	17-1/2"	5"	



4 Drawer Service Cart 37" x 20" - Super Heavy Duty

842926 / JTC-37204

- Extra heavy gauge steel shell for professional use
- Ball bearing slides rated for 100 lb/pair
- 4 drawers, large bottom shelf, and generous under-lid room provide ample storage
- Raise and Release drawer retainer system prevents drawers opening while moving cart
- Long tool storage racks on both sides of cart are secured when lid is locked
- Rear drawer lock mechanism for added security
- Gas shocks support lid in open position
- Shocks can be disconnected allowing lid to lay flat against back of cart
- Stiffener plate strengthens lid and prevents warping
- 4 way swivel polyurethane casters with chrome wheels for maximum maneuverability and smooth rolling
- Comfortable tube steel handle
- Complete with drawer liners

	Width	Depth	Height	Overall Weight
OVERALL	40-1/2"	21-1/8"	40-1/2"	166 lb
2 DRAWERS	15"	17"	3"	
1 DRAWER	32-1/4"	17"	3"	
1 DRAWER	32-1/4"	17"	5"	
SHELF	36-1/2"	19-1/2"	3"	
UNDER LID	36-1/2"	19-1/2"	6"	





SHOP CARTS

- Ideal for garage, office and warehouse applications
- Transport tools around the shop and add much needed workspace
- Heavy gauge steel with enamel finish
- 4 swivel casters (2 free and 2 locking)

2 Shelf Shop Cart - Heavy Duty

PROD. NO.	MOD. NO.	Width	Depth	Height	Shipping Weight
842902	JSC-232	32"	17"	36"	38.5 lb (17 kg)



3 Shelf Shop Cart - Heavy Duty

PROD. NO.	MOD. NO.	Width	Depth	Height	Shipping Weight
842907	JSC-332	30"	16"	36"	38.5 lb (17 kg)



Polypropylene Shop Cart - Heavy Duty

- Heavy duty Polypropylene construction supports up to 500 lb
- Two large 36" x 24" trays with 3" lip keeps items securely on board
- Convenient organizer tray moulded into handle
- Will not dent, rust, chip, or peel
- Resists oil and many chemicals
- 5" x 1" non-marking casters
- Quiet rolling cart is ideal for office use

PROD. NO.	MOD. NO.	Width	Depth	Height	Product Weight
842909	JPTC-3624	46"	25-1/2"	33-1/4"	51 lb (23kg)

3 Shelf Workbench - Heavy Duty

- Top shelf holds up to 1,750 lb
- Lower shelves hold up to 550 lb each
- 2" wall around sides and back
- Rolled edges for added strength and rigidity
- Electrostatic oven baked powder coat paint finish
- Top - 3mm rolled edge, shelves - 2mm rolled edge

PROD. NO.	MOD. NO.	Width	Depth	Height	Shelves
843002	JWB-7925	79"	25"	34-1/2"	3

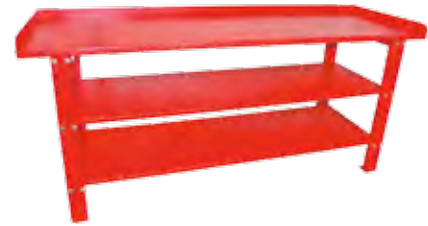

2 Drawer Workbench - Heavy Duty

- Top shelf holds up to 1,750 lb
- Lower shelf holds up to 550 lb
- Drawers holds up to 85 lb each
- Full extension ball bearing drawer slides
- 2" wall around sides and back
- Rolled edges for added strength and rigidity
- Electrostatic over baked powder coat paint finish
- Top - 3mm rolled edge, shelf - 2mm rolled edge

PROD. NO.	MOD. NO.	Width	Depth	Height	Shelves
843003	JWB-5925	59"	25"	34-1/2"	2



Tear Down Table/Workbench - Heavy Duty

- Fluids drain through table top into a removable plastic container (included)
- Comes with locking storage drawer on ball bearing slides
- Multiple shelf locations gives added versatility
- Square tube leg design gives added strength and stability to table top
- Large 4" heavy duty swivel casters (2 locking)
- Table top features 1/2" rim
- Extra heavy duty construction
- Capacity: 1,000 lb

PROD. NO.	MOD. NO.	Width	Depth	Height	Shelves
843012	JTTD-1000	47"	31-1/2"	39-3/4"	2





TOOL ORGANIZERS

- Aluminum rails with engineered nylon pegs, hooks, and clamps for professional use
- Keeps work space organized for maximum efficiency
- All components resistant to rust, corrosion, and most shop chemicals
- Tool holders can be moved to provide adequate spacing between tools
- Unbreakable in normal use
- Mounting hardware included

Socket Organizers

PROD. NO.	MOD. NO.	Total Pegs	Socket Drive
841011	JWSR-1414	14	1/4"
841021	JWSR-3814	14	3/8"
841031	JWSR-1214	14	1/2"



841011



841021



841031

1/4, 3/8, 1/2" Drive Socket Organizer

- Unique socket pegs can be rotated 360° to keep size markings in view
- Spring ball locks sockets onto pegs for use as portable rack or drawer organizer

PROD. NO.	MOD. NO.	Total Pegs	Socket Drive
841151	JTSR-344	44	16 x 1/4", 14 x 3/8", 14 x 1/2"



*Tools not included

www.surewerx.com

- Aluminum rails with engineered nylon pegs, hooks, and clamps for professional use
- Keeps work space organized for maximum efficiency
- All components resistant to rust, corrosion, and most shop chemicals
- Tool holders can be moved to provide adequate spacing between tools
- Unbreakable in normal use
- Mounting hardware included

Combination Wrench Organizer

PROD. NO.	MOD. NO.	Total Pegs
841051	JWWR-1200	12



Screwdriver Organizer

PROD. NO.	MOD. NO.	Total Pegs
841056	JWSDR-1200	12



Tool Organizer

- Lock knobs keep tool clamps in place allowing customization of rack for many types of tools

PROD. NO.	MOD. NO.	Total Pegs
841061	JWTR-600	6



**Tools not included*



841112



841113

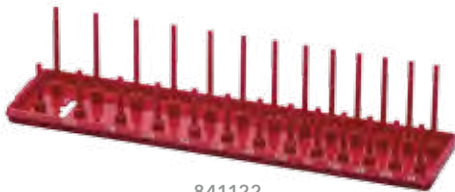

841122



841123



841132



841133

TOOL ORGANIZERS

Socket Organizer Trays

- High impact ABS socket trays resist oil and grease
- Sizes marked at top of posts for quick and easy identification
- Trays hold one shallow and one deep socket of each size
- Coloured red for SAE sockets and blue for metric sockets
- Ideal for bench top use
- Fits most brands of sockets

PROD. NO.	MOD. NO.	Description	No. of Pegs	Sizes
841112	JST-1426S	1/4" Drive SAE	26	1/8, 5/32, 3/16, 7/32, 1/4, 9/32, 5/16, 11/32, 3/8, 7/16, 1/2, 9/16, 5/8"
841113	JST-1428M	1/4" Drive Metric	28	4, 4.5, 5, 5.5, 6, 7, 8, 9, 10, 11, 12, 13, 14, 15 mm
841122	JST-3826S	3/8" Drive SAE	26	1/4, 5/16, 3/8, 7/16, 1/2, 9/16, 5/8, 11/16, 3/4, 13/16, 7/8, 15/16, 1"
841123	JST-3830M	3/8" Drive Metric	30	6, 7, 8, 9, 10, 11, 12, 13, 14, 15, 16, 17, 18, 19, 20 mm
841132	JST-1228S	1/2" Drive SAE	28	3/8, 7/16, 1/2, 9/16, 5/8, 11/16, 3/4, 13/16, 7/8, 15/16, 1, 1-1/16, 1-1/8, 1-1/4"
841133	JST-1234M	1/2" Drive Metric	34	10, 11, 12, 13, 14, 15, 16, 17, 18, 19, 20, 21, 22, 23, 24, 25, 27 mm

NEW

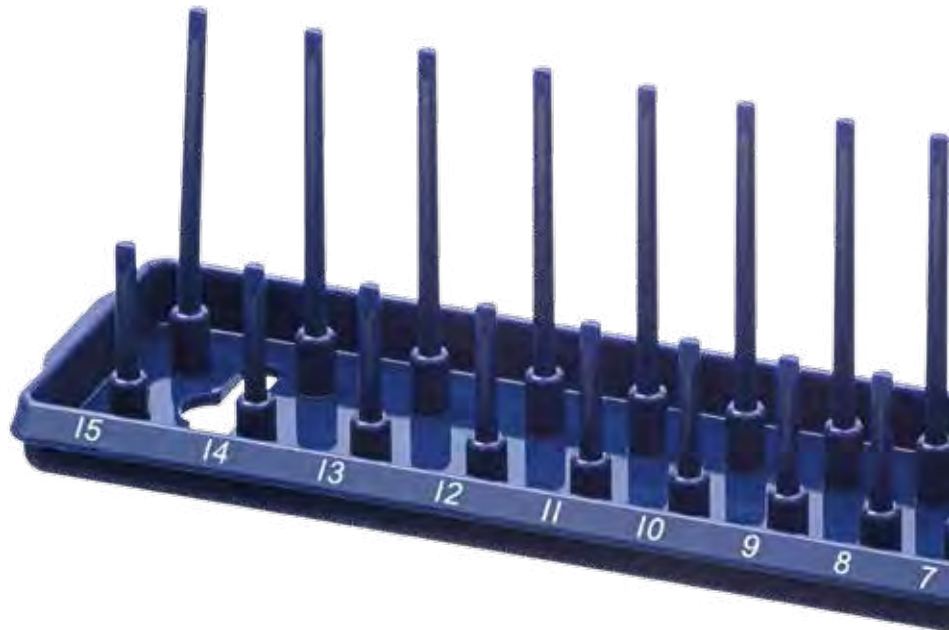



RATCHET WRENCHES





670926 - 672927

Includes bonus MHR-3860 (671941)
3/8" drive mini head ratchet



690106



670929 - 672929

1/4", 3/8" & 1/2" DRIVE

RHQ Series Oval Head

- All components are forged from superior quality Chrome Vanadium steel
- New increased tooth configurations offer finer ratcheting mechanisms
- Available in regular and extra long models
- Push button quick release feature holds sockets on securely until ready to release
- Convenient reversing switch can be operated with one hand
- Comfortable handle style
- Mirror polish finish
- Repair kits available
- All ratchets are designed for use by professionals
- Meets or exceeds ANSI specifications

PROD. NO.	MOD. NO.	Drive	Length (overall)	Teeth	Quick Release
670926	RHQ-14	1/4"	5-1/2"	48	Yes
670928	RHQ-14L	1/4"	7"	48	Yes
671926	RHQ-38	3/8"	8"	48	Yes
671945	RHQ-38L	3/8"	11-3/4"	48	Yes
672926	RHQ-12	1/2"	10"	48	Yes
672927	RHQ-12L	1/2"	15"	48	Yes



3 PC RHQ Series Set

- Contains one each of 1/4, 3/8 and 1/2" RHQ ratchets
- **Includes bonus MHR-3860 (671941) 3/8" drive mini head ratchet!**

PROD. NO.	MOD. NO.	Drive	Pieces	Teeth	Quick Release
690106	RHQ-3SB	1/4, 3/8, 1/2"	3	48/60	Yes



RHQ-F Series Oval Head - Heavy Duty

- Flex head feature allows access into awkward locations
- Same quality features as our RHQ series

PROD. NO.	MOD. NO.	Drive	Length (overall)	Teeth	Quick Release
670929	RHQ-14F	1/4"	6-1/4"	48	Yes
671942	RHQ-38FS	3/8"	4-1/2"	48	Yes
671943	RHQ-38F2	3/8"	11-1/2"	48	Yes
672929	RHQ-12F	1/2"	17-1/2"	48	Yes

Replacement repair kits listed at the back of the Hand Tools section

HT72 Series High Torque

- All metal components are forged from superior quality Chrome Vanadium steel
- High torque 72 tooth twin pawl ratcheting system exceeds ANSI standards for torque
- 5° maximum movement between each engagement of teeth
- Push button quick release feature holds sockets on securely until ready to release
- Comfortable ergonomic handle design with anti-slip strips improves gripping power and reduces operator fatigue
- Spinner ring for use in areas with restricted space
- Convenient hanging hole
- Patented offset ratchet handle offers unique safety features - reduces knuckle damage and improves socket positioning
- Repair kits available

PROD. NO.	MOD. NO.	Drive	Length (overall)	Teeth	Quick Release
670927	HT-1472	1/4"	5-1/2"	72	Yes
671928	HT-3872	3/8"	7-3/4"	72	Yes
672928	HT-1272	1/2"	10"	72	Yes



671928

3 PC HT72 Series Set

690104 / HT-72S

- Contains 1 each: 1/4, 3/8 and 1/2" ratchets above



Replacement repair kits listed at the back of the Hand Tools section



Push through anvil
to reverse direction



TWIST

671923



670922

671922

672922



890512

1/4", 3/8" & 1/2" DRIVE

Twist Drive Ratchets

- Patented Twist Drive action drives sockets without swinging handle - 0° swing arc!
- Special design drives socket in one direction while twisting handle in both directions
- Allows for super fast running of fasteners when space is limited
- Works like a regular ratchet for additional torque
- Co-moulded handle materials provide all day comfort and non-slip grip
- Chrome Vanadium steel handle with Chrome Molybdenum drive gears for maximum strength
- Available in 6 piece POP display

PROD. NO.	MOD. NO.	Drive	Length (overall)	Teeth
671923	TD-3860	3/8"	9-1/4"	60
672923	TD-1260	1/2"	11-1/2"	60



270° Swivel Head Ratchets

- Unique 270° rotating head provides ultimate flex head function
- Only the head rotates, providing maximum flex positions while maintaining smallest profile
- 72 tooth quick release ratchet head requires only 5° swing room
- Convenient direction switch on head is accessible from any angle
- Chrome Vanadium steel handle with Chrome Molybdenum drive gears
- Co-moulded handle grip provides all day comfort and sure grip
- Available in 9 piece POP display (3 of each drive size) - **890512**

PROD. NO.	MOD. NO.	Drive	Length (overall)	Teeth	Quick Release
670922	SH270-14	1/4"	5-7/8"	72	Yes
671922	SH270-38	3/8"	9-1/4"	72	Yes
672922	SH270-12	1/2"	11-7/8"	72	Yes



Replacement repair kits listed at the back of the Hand Tools section

1/4", 3/8" & 1/2" DRIVE

Special Purpose Ratchets



Mini Head Ratchet Wrench

- Mini head and ultra slim body design allows access into confined areas
- Smooth, 60 tooth ratcheting action offers an extremely small swing area - 6°
- Push button quick release
- Full polish, mirror finish

PROD. NO.	MOD. NO.	Drive	Length (overall)	Teeth	Quick Release
671941	MHR-3860	3/8"	7-3/4"	60	Yes

Articulating Head Ratchet Wrench

- 3/8" drive ratchet head rotates around articulating joint, providing up to 8x the speed of a regular ratchet
- Rotating head can be locked in any position to clear obstacles and provide maximum access
- 6140 Chrome Vanadium steel for professional use
- Mirror polished finish
- Meets ANSI torque rating for 3/8" drive ratchets

PROD. NO.	MOD. NO.	Drive	Length (overall)	Teeth	Quick Release
671944	HSR-3800	3/8"	10-1/4"	48	Yes



4 PC Ratchet Wrench Adapter Set

701196 / RWAS-4

- 1/4", 3/8", and 1/2" socket adapters and 1/4" hex bit adapter provide maximum versatility by turning your ratcheting wrench set into a full wrench, bit, and socket drive set
 - Converts the wrench into an extremely low profile ratchet for access to the most limited spaces
 - Works with flat, reversing, and flex head ratcheting combination wrenches
 - Requires 3/8", 1/2", and 3/4" ratcheting wrenches (sold separately)
 - Available in 4 pc set only
- Contents:
- 1/4" hex bit adapter for use with 3/8" ratcheting wrench
 - 1/4" drive socket adapter for use with 3/8" ratcheting wrench
 - 3/8" drive socket adapter for use with 1/2" ratcheting wrench
 - 1/2" drive socket adapter for use with 3/4" ratcheting wrench
 - Ratchet wrenches sold separately



Replacement repair kits listed at the back of the Hand Tools section



Mini Head



Articulating Joint

Push Button Quick Release

671941

671944



Adapter set converts ratcheting combination wrenches to socket or bit drivers

Socket adapters complete with quick release feature





1/4", 3/8" & 1/2" DRIVE

Ratcheting Adapters

- 3 way ratcheting adapters turn any suitably sized flex bar, sliding T-Bar, or extension bar into a reversible ratchet
- Square drive hole plus round through hole allows use with most drive tools
- Can also be used as a finger ratchet
- Chrome Vanadium steel with Chrome Molybdenum drive anvil for maximum strength
- 52 teeth requires just 7° swing arc for use in very close quarters
- Blow mould case

3 Piece Set

PROD. NO.	MOD. NO.	Drive	Pieces
690107	RA352	1/4", 3/8", 1/2"	3

Open Stock

PROD. NO.	MOD. NO.	Drive	Pieces
670921	RA1452	1/4"	Open Stock
671921	RA3852	3/8"	Open Stock
672921	RA1252	1/2"	Open Stock

CrMo CrV

JET ratcheting adapters provide the most versatile system for all your ratcheting needs.



These adapters can be used with:
1. All lengths of flex bars



2. Sliding T-Bars



3. Socket Extensions



Replacement repair kits listed at the back of the Hand Tools section

RH Series

- ANSI rated
- Repair kits available
- Professional quality at an economical price

PROD. NO.	MOD. NO.	Drive	Length (overall)	Teeth	Quick Release
673901	RH-75	3/4"	20"	42	No
674901	RH-100	1"	26"	24	No

RHQ Series Oval Head - Heavy Duty

PROD. NO.	MOD. NO.	Drive	Length (overall)	Teeth	Quick Release
673922	RHQ-34	3/4"	19-1/2"	24	Yes



HT72 Series High Torque - Heavy Duty

- 72 teeth require just 5° swing room to engage next tooth
- Ideal for fasteners in restricted areas
- Extra heavy pawl spring keeps 8 teeth engaged at all times for maximum strength
- Quick release feature locks accessories to ratchet
- One piece drop forged head and handle

PROD. NO.	MOD. NO.	Drive	Length (overall)	Teeth	Quick Release
673924	HT-3472	3/4"	20"	72	Yes

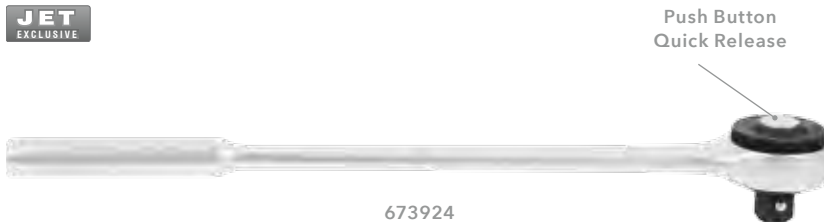

7 PC Telescope Tool Set

690105 / SDK3407

STANDARD ACCESSORIES:

- 40 tooth super duty reversible ratchet (673923)
- 20-32" telescoping drive handle (for use with all items in kit) (673914)
- 4" extension (673903)
- 3/4" Female x 1" Male adapter (673912)
- Sliding T-handle head (673910)
- Flex joint head (673911)
- Blow mould case



Replacement repair kits listed at the back of the Hand Tools section



674906



673923



3/4" & 1" DRIVE

RHD Series - Super Heavy Duty

- All components made from the best quality Chrome Vanadium steel
- Designed to withstand the toughest applications
- Handles sold separately

Heads

PROD. NO.	MOD. NO.	Drive	Teeth	Quick Release
673923	RHD3400	3/4"	40	No
674906	RHD1036	1"	36	No

CrV

Handles

PROD. NO.	MOD. NO.	Length (Overall)
673913	DH3400	20" for 673923 (RHD3400), 673910 (SA7509), 673911 (SA7510)
673914	TDH3400	20" - 32" for 673923 (RHD3400), 673910 (SA7509), 673911 (SA7510)
674907	DH1036	25" for 677906 (RHD1036)

CrV

For 3/4" heads



673913

20 - 32"



673914

For 1" heads



674907

Replacement repair kits listed at the back of the Hand Tools section

CHROME SOCKETS





TORQUE DRIVE



1/4" DR SOCKET WRENCH SETS

- All components forged from high quality Chrome Vanadium steel
- TORQUE DRIVE® sockets contact the fastener on the sides rather than the corners, reducing corner rounding and allowing 20% more torque
- Chamfered edges allow easiest socket placement on fastener, increasing productivity and reducing frustration
- Extra long deep sockets ensure maximum accessibility
- Meets or exceeds U.S. Federal Specs: GGG-W-641E and Canadian Government Specs: CDA39-GP-12b and ANSI specifications

24 PC SAE - 6 Point

600115 / SW1424-6

STANDARD LENGTH SAE

3/16, 7/32, 1/4, 9/32, 5/16, 11/32, 3/8, 7/16, 1/2"

DEEP LENGTH SAE

3/16, 7/32, 1/4, 9/32, 5/16, 11/32, 3/8, 7/16, 1/2"

STANDARD ACCESSORIES:

- 48 tooth 5-1/2" quick release oval head ratchet (670926)
- 2" (670904) and 6" (670906) extensions
- 6" spinner handle (670912)
- 1-3/8" universal joint (670908)
- Blow mould case with removable lid

6 CrV



28 PC Metric - 6 Point

600116 / SW1428M-6

STANDARD LENGTH METRIC

4, 5, 5.5, 6, 7, 8, 9, 10, 11, 12, 13 mm

DEEP LENGTH METRIC

4, 5, 5.5, 6, 7, 8, 9, 10, 11, 12, 13 mm

STANDARD ACCESSORIES:

- 48 tooth 5-1/2" quick release oval head ratchet (670926)
- 2" (670904) and 6" (670906) extensions
- 6" spinner handle (670912)
- 1-3/8" universal joint (670908)
- Blow mould case with removable lid

6 CrV



WARNING: Do not use chrome sockets on impact wrenches

42 PC SAE/Metric - 6 Point

600125 / SW1442C-6

STANDARD LENGTH SAE

3/16, 7/32, 1/4, 9/32, 5/16, 11/32, 3/8, 7/16, 1/2"

DEEP LENGTH SAE

3/16, 7/32, 1/4, 9/32, 5/16, 11/32, 3/8, 7/16, 1/2"

STANDARD LENGTH METRIC

4, 5, 6, 7, 8, 9, 10, 11, 12 mm

DEEP LENGTH METRIC

4, 5, 6, 7, 8, 9, 10, 11, 12 mm

STANDARD ACCESSORIES:

- 72 tooth high torque ratchet (670927)
- 2" (670904) and 4" (670915) extensions
- 6" spinner handle (670912)
- 1-3/8" universal joint (670908)
- Blow mould case with removable lid



TORQUE DRIVE



42 PC SAE/Metric - 12 Point

600126 / SW1442C-12

STANDARD LENGTH SAE

3/16, 7/32, 1/4, 9/32, 5/16, 11/32, 3/8, 7/16, 1/2"

DEEP LENGTH SAE

3/16, 7/32, 1/4, 9/32, 5/16, 11/32, 3/8, 7/16, 1/2"

STANDARD LENGTH METRIC

4, 5, 6, 7, 8, 9, 10, 11, 12 mm

DEEP LENGTH METRIC

4, 5, 6, 7, 8, 9, 10, 11, 12 mm

STANDARD ACCESSORIES:

- 72 tooth high torque ratchet (670927)
- 2" (670904) and 4" (670915) extensions
- 6" spinner handle (670912)
- 1-3/8" universal joint (670908)
- Blow mould case with removable lid



WARNING: Do not use chrome sockets on impact wrenches

TORQUE DRIVE

3/8" DR SOCKET WRENCH SETS

- All components forged from high quality Chrome Vanadium steel
- TORQUE DRIVE® sockets contact the fastener on the sides rather than the corners, reducing corner rounding and allowing 20% more torque
- Chamfered edges allow easiest socket placement on fastener, increasing productivity and reducing frustration
- Extra long deep sockets ensure maximum accessibility
- Meets or exceeds U.S. Federal Specs: GGG-W-641E and Canadian Government Specs: CDA39-GP-12b and ANSI specifications

11 PC SAE - 6 Point

600223 / SW3811-6

STANDARD LENGTH SAE

5/16, 3/8, 7/16, 1/2, 9/16, 5/8, 11/16, 3/4"

STANDARD ACCESSORIES:

- 48 tooth 8" quick release oval head ratchet (**671926**)
- 6" extension (**671907**)
- Blow mould case

6 CrV

15 PC Metric - 6 Point

600226 / SW3815M-6

STANDARD LENGTH METRIC

8, 9, 10, 11, 12, 13, 14, 15, 16, 17, 18, 19 mm

STANDARD ACCESSORIES:

- 48 tooth 8" quick release oval head ratchet (**671926**)
- 6" extension (**671907**)
- Blow mould case

6 CrV

21 PC SAE - 6 Point

600229 / SW3821-6

STANDARD LENGTH SAE

3/8, 7/16, 1/2, 9/16, 5/8, 11/16, 3/4"

DEEP LENGTH SAE

3/8, 7/16, 1/2, 9/16, 5/8, 11/16, 3/4, 13/16"

STANDARD ACCESSORIES:

- 48 tooth 8" quick release oval head ratchet (**671926**)
- 3" (**671905**) and 6" (**671907**) extensions
- 8" flex handle (**671902**)
- 1-7/8" universal joint (**671910**)
- Blow mould case with removable lid

6 CrV

⚠ WARNING: Do not use chrome sockets on impact wrenches

30 PC Metric - 6 Point

600234 / SW3830M-6

STANDARD LENGTH METRIC

8, 9, 10, 11, 12, 13, 14, 15, 16, 17, 18, 19 mm

DEEP LENGTH METRIC

8, 9, 10, 11, 12, 13, 14, 15, 16, 17, 18, 19 mm

STANDARD ACCESSORIES:

- 48 tooth 8" quick release oval head ratchet (671926)
- 3" (671905) and 6" (671907) extensions
- 8" flex handle (671902)
- 1-7/8" universal joint (671910)
- Blow mould case with removable lid

6 CrV



TORQUE DRIVE



45 PC SAE/Metric - 6 Point

600241 / SW3845C-6

STANDARD LENGTH SAE

3/8, 7/16, 1/2, 9/16, 5/8, 11/16, 3/4"

DEEP LENGTH SAE

3/8, 7/16, 1/2, 9/16, 5/8, 11/16, 3/4, 13/16"

STANDARD LENGTH METRIC

8, 9, 10, 11, 12, 13, 14, 15, 16, 17, 18, 19 mm

DEEP LENGTH METRIC

8, 9, 10, 11, 12, 13, 14, 15, 16, 17, 18, 19 mm

STANDARD ACCESSORIES:

- 72 tooth high torque ratchet (671928)
- 3" (671905) and 6" (671907) extensions
- 8" flex handle (671902)
- 1-7/8" universal joint (671910)
- Blow mould case with removable lid

6 CrV



45 PC SAE/Metric - 12 Point

600242 / SW3845C-12

STANDARD LENGTH SAE

3/8, 7/16, 1/2, 9/16, 5/8, 11/16, 3/4"

DEEP LENGTH SAE

3/8, 7/16, 1/2, 9/16, 5/8, 11/16, 3/4, 13/16"

STANDARD LENGTH METRIC

8, 9, 10, 11, 12, 13, 14, 15, 16, 17, 18, 19 mm

DEEP LENGTH METRIC

8, 9, 10, 11, 12, 13, 14, 15, 16, 17, 18, 19 mm

STANDARD ACCESSORIES:

- 72 tooth high torque ratchet (671928)
- 3" (671905) and 6" (671907) extensions
- 8" flex handle (671902)
- 1-7/8" universal joint (671910)
- Blow mould case with removable lid

12 CrV



WARNING: Do not use chrome sockets on impact wrenches

HEAT TREATED FOR PROFESSIONAL USE

TORQUE DRIVE®

1/2" DR SOCKET WRENCH SETS

- All components forged from high quality Chrome Vanadium steel
- TORQUE DRIVE® sockets contact the fastener on the sides rather than the corners, reducing corner rounding and allowing 20% more torque
- Chamfered edges allow easiest socket placement on fastener, increasing productivity and reducing frustration
- Extra long deep sockets ensure maximum accessibility
- Meets or exceeds U.S. Federal Specs: GGG-W-641E and Canadian Government Specs: CDA39-GP-12b and ANSI specifications



19 PC Metric - 6 Point

600326 / SW1219M-6

STANDARD LENGTH METRIC

12, 13, 14, 15, 16, 17, 18, 19, 20, 21, 22, 23, 24 mm

STANDARD ACCESSORIES:

- 48 tooth 10" quick release oval head ratchet (672926)
- 5" (672905) and 10" (672906) extensions
- 15" flex handle (672903)
- 2-3/4" universal joint (672908)
- Blow mould case with removable lid

6 CrV



20 PC SAE - 6 Point

600323 / SW1220-6

STANDARD LENGTH SAE

7/16, 1/2, 9/16, 5/8, 11/16, 3/4, 13/16, 7/8, 15/16, 1, 1-1/16, 1-1/8, 1-3/16, 1-1/4"

STANDARD ACCESSORIES:

- 48 tooth 10" quick release oval head ratchet (672926)
- 5" (672905) and 10" (672906) extensions
- 15" flex handle (672903)
- 2-3/4" universal joint (672908)
- Blow mould case

6 CrV



 **WARNING:** Do not use chrome sockets on impact wrenches

HIGH QUALITY CHROME VANADIUM STEEL

1/2" DR SOCKET WRENCH SETS

29 PC SAE - 6 Point

600331 / SW1229-6

STANDARD LENGTH SAE

3/8, 7/16, 1/2, 9/16, 5/8, 11/16, 3/4, 13/16, 7/8, 15/16, 1, 1-1/16, 1-1/8, 1-3/16, 1-1/4"

DEEP LENGTH SAE

7/16, 1/2, 9/16, 5/8, 11/16, 3/4, 7/8"

STANDARD ACCESSORIES:

- 48 tooth 10" quick release oval head ratchet (672926)
- 2" (672904), 5" (672905) and 10" (672906) extensions
- 10" sliding T-handle (672907)
- 2-3/4" universal joint (672908)
- Blow mould case with removable lid

6 CrV



TORQUE DRIVE®



55 PC SAE/Metric - 6 Point

600341 / SW1255C-6

STANDARD LENGTH SAE

3/8, 7/16, 1/2, 9/16, 5/8, 11/16, 3/4, 13/16, 7/8, 15/16, 1, 1-1/16, 1-1/8, 1-3/16, 1-1/4"

DEEP LENGTH SAE

7/16, 1/2, 9/16, 5/8, 11/16, 3/4, 7/8"

STANDARD LENGTH METRIC

10, 11, 12, 13, 14, 15, 16, 17, 18, 19, 21, 22, 23, 24, 27, 30, 32mm

DEEP LENGTH METRIC

10, 12, 13, 14, 15, 16, 17, 18, 19, 21 mm

STANDARD ACCESSORIES:

- 72 tooth high torque ratchet (672928)
- 2" (672904), 5" (672905) and 10" (672906) extensions
- 10" sliding T-handle (672907)
- 2-3/4" universal joint (672908)
- Blow mould case with removable lid

6 CrV



WARNING: Do not use chrome sockets on impact wrenches



TORQUE DRIVE



3/4" DR SOCKET WRENCH SETS

- All components forged from high quality Chrome Vanadium steel
- Chamfered edges allow easiest socket placement on fastener, increasing productivity and reducing frustration
- Meets or exceeds U.S. Federal Specs: GGG-W-641E and Canadian Government Specs: CDA39-GP-12b and ANSI specifications

7 PC Telescope Tool Set

690105 / SDK3407

STANDARD ACCESSORIES:

- 40 tooth super duty reversible ratchet (673923)
- 20-32" telescoping drive handle (for use with all items in kit) (673914)
- 4" extension (673903)
- 3/4" Female x 1" Male adapter (673912)
- Sliding T-handle head (673910)
- Flex joint head (673911)
- Blow mould case

CrV



21 PC SAE - 12 Point

600402 / SW7521

STANDARD LENGTH SAE

3/4, 7/8, 15/16, 1, 1-1/16, 1-1/8, 1-3/16, 1-1/4, 1-5/16, 1-3/8, 1-7/16, 1-1/2, 1-5/8, 1-3/4, 1-7/8, 2"

STANDARD ACCESSORIES:

- 42 tooth 20" round head ratchet (673901)
- 4" (673903) and 8" (673904) extensions
- 18" sliding T-handle (673906)
- Metal case

12 CrV



21 PC SAE - 12 Point

600406 / SW7521-HD

STANDARD LENGTH SAE

3/4, 7/8, 15/16, 1, 1-1/16, 1-1/8, 1-3/16, 1-1/4, 1-5/16, 1-3/8, 1-7/16, 1-1/2, 1-5/8, 1-3/4, 1-7/8, 2"

STANDARD ACCESSORIES:

- 24 tooth 19-1/2" deluxe oval head ratchet (673922)
- 4" (673903) and 8" (673904) extensions
- 18" sliding T-handle (673906)
- Blow mould case

12 CrV



Heavy Duty Ratchet

WARNING: Do not use chrome sockets on impact wrenches

1" DR SOCKET WRENCH SETS



- All components forged from high quality Chrome Vanadium steel
- TORQUE DRIVE® sockets contact the fastener on the sides rather than the corners, reducing corner rounding and allowing 20% more torque
- Chamfered edges allow easiest socket placement on fastener, increasing productivity and reducing frustration
- Extra long deep sockets ensure maximum accessibility
- Meets or exceeds U.S. Federal Specs: GGG-W-641E and Canadian Government Specs: CDA39-GP-12b and ANSI specifications



17 PC SAE - 12 Point

600505 / SW1017

STANDARD LENGTH SAE

**1-7/16, 1-1/2, 1-5/8, 1-11/16, 1-3/4, 1-7/8, 2, 2-3/16,
2-1/4, 2-3/8, 2-1/2"**

STANDARD ACCESSORIES:

- 24 tooth heavy duty reversible ratchet head (674901)
- 8" (674905) and 16" (674903) extensions
- 22" universal handle (included with 674901)
- Sliding T-head
- Metal case



21 PC SAE - 12 Point

600503 / SW1021

STANDARD LENGTH SAE

**1-7/16, 1-1/2, 1-5/8, 1-11/16, 1-3/4, 1-13/16,
1-7/8, 2, 2-1/8, 2-3/16, 2-1/4, 2-3/8, 2-1/2, 2-5/8,
2-3/4, 2-15/16, 3-1/8"**

STANDARD ACCESSORIES:

- 24 tooth heavy duty reversible ratchet head (674901)
- 8" (674905) and 16" (674903) extensions
- 22" universal handle (included with 674901)
- Sliding T-head
- Metal case



WARNING: Do not use chrome sockets on impact wrenches



TORQUE DRIVE



1/4" DR SOCKET SETS

- All components forged from high quality Chrome Vanadium steel
- TORQUE DRIVE® sockets contact the fastener on the sides rather than the corners, reducing corner rounding and allowing 20% more torque
- Chamfered edges allow easiest socket placement on fastener, increasing productivity and reducing frustration
- Extra long deep sockets ensure maximum accessibility
- Meets or exceeds U.S. Federal Specs: GGG-W-641E and Canadian Government Specs: CDA39-GP-12b and ANSI specifications

9 PC SAE - 6 Point

601102 / SS1409-6

STANDARD LENGTH SAE

3/16, 7/32, 1/4, 9/32, 5/16, 11/32, 3/8, 7/16, 1/2"

- Includes socket rail

6 CrV

9 PC Deep SAE - 6 Point

601107 / SS1409D-6

DEEP LENGTH SAE

3/16, 7/32, 1/4, 9/32, 5/16, 11/32, 3/8, 7/16, 1/2"

- Includes socket rail

6 CrV

11 PC Metric - 6 Point

601113 / SS1411M-6

STANDARD LENGTH METRIC

4, 5, 5.5, 6, 7, 8, 9, 10, 11, 12, 13 mm

- Includes socket rail

6 CrV

11 PC Deep Metric - 6 Point

601118 / SS1411DM-6

DEEP LENGTH METRIC

4, 5, 5.5, 6, 7, 8, 9, 10, 11, 12, 13 mm

- Includes socket rail

6 CrV

⚠ WARNING: Do not use chrome sockets on impact wrenches

3/8" DR SOCKET SETS



- All components forged from high quality Chrome Vanadium steel
- TORQUE DRIVE® sockets contact the fastener on the sides rather than the corners, reducing corner rounding and allowing 20% more torque
- Chamfered edges allow easiest socket placement on fastener, increasing productivity and reducing frustration
- Extra long deep sockets ensure maximum accessibility
- Meets or exceeds U.S. Federal Specs: GGG-W-641E and Canadian Government Specs: CDA39-GP-12b and ANSI specifications

TORQUE DRIVE®

8 PC SAE - 6 Point

601219 / SS3808-6

STANDARD LENGTH SAE

5/16, 3/8, 7/16, 1/2, 9/16, 5/8, 11/16, 3/4"

- Includes socket rail

6 CrV



8 PC Deep SAE - 6 Point

601220 / SS3808D-6

DEEP LENGTH SAE

3/8, 7/16, 1/2, 9/16, 5/8, 11/16, 3/4, 13/16"

- Includes socket rail

6 CrV



9 PC SAE - 12 Point

601227 / SS3809-12

STANDARD LENGTH SAE

1/4, 5/16, 3/8, 7/16, 1/2, 9/16, 5/8, 11/16, 3/4"

- Includes socket rail

12 CrV



9 PC Deep SAE - 12 Point

601229 / SS3809D-12

DEEP LENGTH SAE

1/4, 5/16, 3/8, 7/16, 1/2, 9/16, 5/8, 11/16, 3/4"

- Includes socket rail

12 CrV



WARNING: Do not use chrome sockets on impact wrenches



TORQUE DRIVE



3/8" DR SOCKET SETS

- All components forged from high quality Chrome Vanadium steel
- TORQUE DRIVE® sockets contact the fastener on the sides rather than the corners, reducing corner rounding and allowing 20% more torque
- Chamfered edges allow easiest socket placement on fastener, increasing productivity and reducing frustration
- Extra long deep sockets ensure maximum accessibility
- Meets or exceeds U.S. Federal Specs: GGG-W-641E and Canadian Government Specs: CDA39-GP-12b and ANSI specifications

12 PC Metric - 6 Point

601224 / SS3812M-6

STANDARD LENGTH METRIC

8, 9, 10, 11, 12, 13, 14, 15, 16, 17, 18, 19 mm

- Includes socket rail

6 CrV

12 PC Metric - 12 Point

601234 / SS3812M-12

STANDARD LENGTH METRIC

8, 9, 10, 11, 12, 13, 14, 15, 16, 17, 18, 19 mm

- Includes socket rail

12 CrV

12 PC Deep Metric - 6 Point

601226 / SS3812DM-6

DEEP LENGTH METRIC

8, 9, 10, 11, 12, 13, 14, 15, 16, 17, 18, 19 mm

- Includes socket rail

6 CrV

12 PC Deep Metric - 12 Point

601236 / SS3812DM-12

DEEP LENGTH METRIC

8, 9, 10, 11, 12, 13, 14, 15, 16, 17, 18, 19 mm

- Includes socket rail

12 CrV

⚠ WARNING: Do not use chrome sockets on impact wrenches

1/2" DR SOCKET SETS



- All components forged from high quality Chrome Vanadium steel
- TORQUE DRIVE® sockets contact the fastener on the sides rather than the corners, reducing corner rounding and allowing 20% more torque
- Chamfered edges allow easiest socket placement on fastener, increasing productivity and reducing frustration
- Extra long deep sockets ensure maximum accessibility
- Meets or exceeds U.S. Federal Specs: GGG-W-641E and Canadian Government Specs: CDA39-GP-12b and ANSI specifications

TORQUE DRIVE®

15 PC SAE - 6 Point

601316 / SS1215-6

STANDARD LENGTH SAE

**3/8, 7/16, 1/2, 9/16, 5/8, 11/16, 3/4, 13/16, 7/8, 15/16, 1, 1-1/16,
1-1/8, 1-3/16, 1-1/4"**

- Includes socket rail



15 PC SAE - 12 Point

601317 / SS1215-12

STANDARD LENGTH SAE

**3/8, 7/16, 1/2, 9/16, 5/8, 11/16, 3/4, 13/16, 7/8, 15/16, 1, 1-1/16,
1-1/8, 1-3/16, 1-1/4"**

- Includes socket rail



13 PC Deep SAE - 6 Point

601313 / SS1213D-6

DEEP LENGTH SAE

7/16, 1/2, 9/16, 5/8, 11/16, 3/4, 13/16, 7/8, 15/16, 1, 1-1/16, 1-1/8, 1-1/4"

- Includes socket rail



13 PC Deep SAE - 12 Point

601318 / SS1213D-12

DEEP LENGTH SAE

7/16, 1/2, 9/16, 5/8, 11/16, 3/4, 13/16, 7/8, 15/16, 1, 1-1/16, 1-1/8, 1-1/4"

- Includes socket rail



WARNING: Do not use chrome sockets on impact wrenches



TORQUE DRIVE®



13 PC Metric - 6 Point

601312 / SS1213M-6

STANDARD LENGTH METRIC

10, 12, 13, 14, 15, 16, 17, 18, 19, 20, 21, 22, 24 mm

- Includes socket rail

6 CrV



14 PC Metric - 12 Point

601319 / SS1214M-12

STANDARD LENGTH METRIC

10, 11, 12, 13, 14, 15, 16, 17, 18, 19, 20, 21, 22, 24 mm

- Includes socket rail

12 CrV



13 PC Deep Metric - 6 Point

601314 / SS1213DM-6

DEEP LENGTH METRIC

10, 12, 13, 14, 15, 16, 17, 18, 19, 20, 21, 22, 24 mm

- Includes socket rail

6 CrV



14 PC Deep Metric - 12 Point

601320 / SS1214DM-12

DEEP LENGTH METRIC

10, 11, 12, 13, 14, 15, 16, 17, 18, 19, 20, 21, 22, 24 mm

- Includes socket rail

12 CrV

⚠ WARNING: Do not use chrome sockets on impact wrenches



3/4" DR SOCKET SETS

- All components forged from high quality Chrome Vanadium steel
- TORQUE DRIVE® sockets contact the fastener on the sides rather than the corners, reducing corner rounding and allowing 20% more torque
- Chamfered edges allow easiest socket placement on fastener, increasing productivity and reducing frustration
- Extra long deep sockets ensure maximum accessibility
- Meets or exceeds U.S. Federal Specs: GGG-W-641E and Canadian Government Specs: CDA39-GP-12b and ANSI specifications

17 PC SAE - 12 Point

601405 / SS3417

STANDARD LENGTH SAE

7/8, 15/16, 1, 1-1/16, 1-1/8, 1-3/16, 1-1/4, 1-5/16, 1-3/8, 1-7/16, 1-1/2, 1-5/8, 1-3/4, 1-13/16, 1-7/8, 2"

- Metal case

12 CrV

17 PC Deep SAE - 6 Point

601407 / SS31417D-6

DEEP LENGTH SAE

7/8, 15/16, 1, 1-1/16, 1-1/8, 1-3/16, 1-1/4, 1-5/16, 1-3/8, 1-7/16, 1-1/2, 1-5/8, 1-3/4, 1-13/16, 1-7/8, 2"

- Metal case

6 CrV

17 PC Metric - 12 Point

601406 / SS3417M

STANDARD LENGTH METRIC

19, 21, 22, 23, 24, 26, 27, 29, 30, 32, 35, 36, 38, 41, 46, 50 mm

- Metal case

12 CrV

! WARNING: Do not use chrome sockets on impact wrenches

TORQUE DRIVE 





HEX BIT SOCKET SETS

- All sockets forged from high quality Chrome Vanadium steel
- Hex bits are made of superior quality S2 steel for maximum strength
- Meets or exceeds U.S. Federal Specs: GGG-W-641E and Canadian Government Specs: CDA39-GP-12b and ANSI B107-10M, B107-1, B107-5

7 PC SAE Hex Bit

601201 / HSW3811

- 3/8" DR
2" (OVERALL LENGTH) SAE HEX BIT SOCKETS:
1/8, 5/32, 3/16, 7/32, 1/4, 5/16, 3/8"
- Includes socket rail



7 PC Metric Hex Bit

601202 / HSW3811M

- 3/8" DR
2" (OVERALL LENGTH) METRIC HEX BIT SOCKETS:
3, 4, 5, 6, 7, 8, 10 mm
- Includes socket rail



10 PC SAE Hex Bit

601802 / HSW3812-10

- 3/8" DR
2" (OVERALL LENGTH) SAE HEX BIT SOCKETS:
1/8, 5/32, 3/16, 7/32, 1/4, 5/16, 3/8"
- 1/2" DR
2-1/4" (OVERALL LENGTH) SAE HEX BIT SOCKETS:
1/2, 9/16, 5/8"
- Includes socket rail



10 PC Metric Hex Bit

601803 / HSW3812-10M

- 3/8" DR
2" (OVERALL LENGTH) METRIC HEX BIT SOCKETS:
3, 4, 5, 6, 7, 8, 10mm
- 1/2" DR
2-1/4" (OVERALL LENGTH) METRIC HEX BIT SOCKETS:
12, 14, 16mm
- Includes socket rail



⚠ WARNING: Do not use chrome sockets on impact wrenches

7 PC SAE Long Ball Nose 601804 / LHSW3807

- 3/8" DR
4" (OVERALL LENGTH) S.A.E EXTRA LONG BALL NOSE HEX BIT SOCKETS:
1/8, 5/32, 3/16, 7/32, 1/4, 5/16, 3/8"
- Includes socket rail



7 PC Metric Long Ball Nose 601805 / LHSW3807M

- 3/8" DR
4" (OVERALL LENGTH) METRIC HEX BIT SOCKETS:
4, 5, 6, 7, 8, 9, 10 mm
- Includes socket rail



14 PC SAE / Metric - Long Series 601808 / LHSW1438-14C

- 4" (OVERALL LENGTH) SAE EXTRA LONG HEX BIT SOCKETS:
- 1/4" DR:
1/8, 5/32, 3/16"
 - 3/8" DR:
7/32, 1/4, 5/16, 3/8"
- 4" (OVERALL LENGTH) METRIC EXTRA LONG HEX BIT SOCKETS:
- 1/4" DR:
4, 5, 6mm
 - 3/8" DR:
7, 8, 9, 10 mm
 - Blow mould case



WARNING: Do not use chrome sockets on impact wrenches



TORX® BITS SOCKET SETS

- All sockets forged from high quality Chrome Vanadium steel
- TORX® bits are made of superior quality S2 steel for maximum strength
- Meets or exceeds U.S. Federal Specs: GGG-W-641E and Canadian Government Specs: CDA39-GP-12b and ANSI specifications



6 PC 3/8" DR - Tamperproof

601216 / SS386TB

2" (OVERALL LENGTH) TORX® BIT SOCKETS:

T25, T30, T40, T45, T50, T55

- Includes socket rail



10 PC 1/4" & 3/8" DR - Tamperproof

601801 / SS1438-10TB

- 1/4" DR
1-1/2" (OVERALL LENGTH) TORX® BIT
T10, T15, T20, T25, T27, T30

- 3/8" DR
2" (OVERALL LENGTH) TORX® BIT
T40, T45, T50, T55

- Includes socket rail



11 PC 1/4" & 3/8" DR

601806 / SS1438-11T

- 1/4" DR
1-1/2" (OVERALL LENGTH) TORX® BIT:
T10, T15, T20, T25, T27, T30
- 3/8" DR 2" (OVERALL LENGTH) TORX® BIT:
T40, T45, T47, T50, T55
- Includes socket rail



WARNING: Do not use chrome sockets on impact wrenches

EXTERNAL TORX® SOCKET SETS



- All components forged from high quality Chrome Vanadium steel
- Chamfered edges

7 PC 1/4" DR 601111 / SS1407TS

STANDARD LENGTH EXTERNAL TORX®

E4, E5, E6, E7, E8, E10, E11

- Includes socket rail



6 PC 3/8" DR 601231 / SS3806TS

STANDARD LENGTH EXTERNAL TORX®

E6, E8, E10, E12, E14, E16

- Includes socket rail



12 PC 3/8" DR 601232 / SS3812TS

STANDARD LENGTH EXTERNAL TORX®

E4, E5, E6, E7, E8, E10, E11, E12, E14, E16, E18, E20

- Includes socket rail



9 PC 1/2" DR 601321 / SS1209TS

STANDARD LENGTH EXTERNAL TORX®

E10, E11, E12, E14, E16, E18, E20, E22, E24

- Includes socket rail



28 PC 1/4", 3/8" and 1/2" DR 601811 / SS328TS

STANDARD LENGTH EXTERNAL TORX®

- 1/4" DR: **E4, E5, E6, E7, E8, E10, E11**
- 3/8" DR: **E4, E5, E6, E7, E8, E10, E11, E12, E14, E16, E18, E20**
- 1/2" DR: **E10, E11, E12, E14, E16, E18, E20, E22, E24**
- Blow mould case



WARNING: Do not use chrome sockets on impact wrenches

- All items meet U.S. Federal Specifications: GGG-W-641e, Canadian Government Specification CDA39-GP-12b and ANSI specifications

Drive Size SAE	1/4" Regular 6 pt.	1/4" Deep 6 pt.	1/4" Regular 12 pt.	1/4" Deep 12 pt.	3/8" Regular 6 pt.	3/8" Deep 6 pt.	3/8" Regular 12 pt.	3/8" Deep 12 pt.
3/16"	670106	670306	670206	670406				
7/32"	670107	670307	670207	670407				
1/4"	670108	670308	670208	670408	671108		671208	671408
9/32"	670109	670309	670209	670409				
5/16"	670110	670310	670210	670410	671110		671210	671410
11/32"	670111	670311	670211	670411				
3/8"	670112	670312	670212	670412	671112	671312	671212	671412
7/16"	670114	670314	670214	670414	671114	671314	671214	671414
1/2"	670116	670316	670216	670416	671116	671316	671216	671416
9/16"					671118	671318	671218	671418
5/8"					671120	671320	671220	671420
11/16"					671122	671322	671222	671422
3/4"					671124	671324	671224	671424
13/16"					671126	671326		
7/8"					671128	671328		
15/16"					671130			
1"					671132			



3/8" DR SPARK PLUG SOCKETS

5 PC Magnetic Spark Plug Socket Set

H3704 / SS1438-11T

- Long reach magnetic swivel spark plug socket set
- For hex sizes 5/8", 13/16" and 9/16" on Ford Triton® engines
- Made from CrV steel, with a bright hard chrome finish

Set Includes:

- 3/8" DR x 9/16" HEX x 2-1/2" (66 mm) Long **H3704-10**
- 3/8" DR x 5/8" HEX x 4" (101.6 mm) Long **H3704-14**
- 3/8" DR x 5/8" HEX x 6" (152.4 mm) Long **H3704-16**
- 3/8" DR x 5/8" HEX x 11" (279.4 mm) Long **H3704-18**
- 3/8" DR x 13/16" HEX x 6" (152.4 mm) Long **H3704-22**



See our
Specialty
Automotive
section
for more
information

Spark Plug Sockets

- Features rubber inserts to protect spark plugs from damage

PROD. NO.	Drive	Hex Size
671932	3/8"	5/8"
671934	3/8"	13/16"

WARNING: Do not use chrome sockets on impact wrenches

- All items meet U.S. Federal Specifications: GGG-W-641e, Canadian Government Specification CDA39-GP-12b and ANSI specifications

Drive	1/2"	1/2"	1/2"	1/2"	3/4"	3/4"	1"
Size SAE	Regular 6 pt.	Deep 6 pt.	Regular 12 pt.	Deep 12 pt.	Regular 12pt.	Deep 6 pt.	Regular 12 pt.
3/8"	672112		672212				
7/16"	672114	672314	672214	672414			
1/2"	672116	672316	672216	672416			
9/16"	672118	672318	672218	672418			
5/8"	672120	672320	672220	672420			
11/16"	672122	672322	672222	672422			
3/4"	672124	672324	672224	672424	673212		
13/16"	672126	672326	672226	672426			
7/8"	672128	672328	672228	672428	673214	673414	
15/16"	672130	672330	672230	672430	673215	673415	
1"	672132	672332	672232	672432	673216	673416	
1-1/16"	672134	672334	672234	672434	673217	673417	
1-1/8"	672136	672336	672236	672436	673218	673418	
1-3/16"	672138		672238		673219	673419	
1-1/4"	672140	672340	672240	672440	673220	673420	
1-5/16"					673221	673421	
1-3/8"					673222	673422	
1-7/16"					673223	673423	674223
1-1/2"					673224	673424	674224
1-9/16"					673225		
1-5/8"					673226	673426	674226
1-11/16"					673227		674227
1-3/4"					673228	673428	674228
1-13/16"					673229	673429	674229
1-7/8"					673230	673430	674230
2"					673232	673432	674232
2-1/8"							674234
2-3/16"							674235
2-1/4"							674236
2-3/8"							674238
2-1/2"							674240
2-5/8"							674242
2-3/4"							674244
2-15/16"							674247
3"							674248
3-1/8"							674250



672414



672228



673224

WARNING: Do not use chrome sockets on impact wrenches

METRIC OPEN STOCK

- All items meet U.S. Federal Specifications: GGG-W-641e, Canadian Government Specification CDA39-GP-12b and ANSI specifications

Drive Size Metric	1/4"		1/4"		3/8"		3/8"	
	Regular 6 pt.	Deep 6 pt.	Regular 12 pt.	Deep 12 pt.	Regular 6 pt.	Deep 6 pt.	Regular 12 pt.	Deep 12 pt.
4 mm	670502	670702	670602	670802				
4.5 mm	670503							
5 mm	670504	670704	670604	670804				
5.5 mm	670505	670705						
6 mm	670506	670706	670606	670806	671506			
7 mm	670507	670707	670607	670807	671507			
8 mm	670508	670708	670608	670808	671508	671708	671608	671808
9 mm	670509	670709	670609	670809	671509	671709	671609	671809
10 mm	670510	670710	670610	670810	671510	671710	671610	671810
11 mm	670511	670711	670611	670811	671511	671711	671611	671811
12 mm	670512	670712	670612	670812	671512	671712	671612	671812
13 mm	670513	670713			671513	671713	671613	671813
14 mm					671514	671714	671614	671814
15 mm					671515	671715	671615	671815
16 mm					671516	671716	671616	671816
17 mm					671517	671717	671617	671817
18 mm					671518	671718	671618	671818
19 mm					671519	671719	671619	671819
20 mm					671520			
21 mm					671521	671721		
22 mm					671522			
23 mm								
24 mm					671524			



 **WARNING:** Do not use chrome sockets on impact wrenches

- All items meet U.S. Federal Specifications: GGG-W-641e, Canadian Government Specification CDA39-GP-12b and ANSI specifications

Drive Size Metric	1/2"		1/2"		3/4"
	Regular 6 pt.	Deep 6 pt.	Regular 12 pt.	Deep 12 pt.	Regular 12 pt.
8 mm	672508				
9 mm	672509				
10 mm	672510	672710	672610	672810	
11 mm	672511		672611	672811	
12 mm	672512	672712	672612	672812	
13 mm	672513	672713	672613	672813	
14 mm	672514	672714	672614	672814	
15 mm	672515	672715	672615	672815	
16 mm	672516	672716	672616	672816	
17 mm	672517	672717	672617	672817	
18 mm	672518	672718	672618	672818	
19 mm	672519	672719	672619	672819	673619
20 mm	672520	672720	672620	672820	
21 mm	672521	672721	672621	672821	673621
22 mm	672522	672722	672622	672822	673622
23 mm	672523	672723			673623
24 mm	672524	672724	672624	672824	673624
26 mm					673626
27 mm	672527	672727			673627
29 mm					673629
30 mm	672530				673630
32 mm	672532				673632
35 mm					673635
36 mm					673636
38 mm					673638
41 mm					673641
46 mm					673646
50 mm					673650



672824



672610

JET-A-SIZER - Fastener Sizing Tool

779901 / JFST-1

- Handy tool quickly and accurately identifies size of nut or bolt head
- Works on 6 point SAE and Metric fasteners
- Eliminates unnecessary trips to the tool box
- Permanently stamped sizes for a lifetime of use
- Integrated keychain hook keeps tool handy
- Measuring range: 5/16 - 1", 8 - 25mm



WARNING: Do not use chrome sockets on impact wrenches



SAE HEX BITS OPEN STOCK

- All sockets forged from high quality Chrome Vanadium steel
- Hex bits are made of superior quality S2 steel for maximum strength
- Meets or exceeds U.S. Federal Specs: GGG-W-641E and Canadian Government Specs: CDA39-GP-12b and ANSI specifications



Long
677130



Regular
677210

Drive Size SAE	1/4" 4" Long	3/8" Regular	3/8" 4" Long	3/8" 4" Long Ball Nose	1/2" Regular
1/8"	677021	677204		677224	
5/32"	677022	677205		677225	
3/16"	677023	677206		677226	
7/32"		677207	677127	677227	
1/4"		677208	677128	677228	
9/32"					
5/16"		677210	677130	677230	
11/32"					
3/8"		677212	677132	677232	
1/2"					677316
9/16"					677318
5/8"					677320



WARNING: Do not use chrome sockets on impact wrenches

Long Ball Nose



METRIC HEX BITS OPEN STOCK



- All sockets forged from high quality Chrome Vanadium steel
- Hex bits are made of superior quality S2 steel for maximum strength
- Meets or exceeds U.S. Federal Specs: GGG-W-641E and Canadian Government Specs: CDA39-GP-12b and ANSI specifications

Drive Size Metric	1/4" 4" Long	3/8" Regular	3/8" 4" Long	3/8" 4" Long Ball Nose	1/2" Regular
3 mm		677253			
4 mm	677071	677254		677274	
5 mm	677072	677255		677275	
6 mm	677073	677256		677276	
7 mm		677257	677177	677277	
8 mm		677258	677178	677278	
9 mm			677179	677279	
10 mm		677260	677180	677280	
12 mm					677362
14 mm					677364
16 mm					677366

NOTE: 3/8" drive regular length sockets = 2" overall length
 1/2" drive regular length sockets = 2-1/4" overall length



Long
677179



Long Ball Nose
677280



Regular
677366

WARNING: Do not use chrome sockets on impact wrenches



677767
tamperproof



677787
Non-tamperproof



677865

TORX® BITS OPEN STOCK

Drive Size TORX®	1/4"	1/4"	3/8"	3/8"
	Non-Tamperproof	Tamperproof	Non-Tamperproof	Tamperproof
T10	677726	677706		
T15	677727	677707		
T20	677728	677708		
T25	677729	677709		677759
T27	677730	677710		
T30	677731	677711		677761
T40			677783	677763
T45			677784	677764
T47			677785	
T50			677786	677766
T55			677787	677767



EXTERNAL TORX® BITS OPEN STOCK

Drive Size External TORX®	1/4"	3/8"	1/2"
	Regular	Regular	Regular
E4	677803	677821	
E5	677804	677822	
E6	677805	677823	
E7	677806	677845	
E8	677807	677824	
E10	677809	677825	677851
E11	677810	677847	677852
E12		677826	677853
E14		677827	677855
E16		677828	677857
E18		677830	677859
E20		677832	677861
E22			677863
E24			677865



WARNING: Do not use chrome sockets on impact wrenches

- All components are forged from high quality Chrome Vanadium steel
- Meets or exceeds U.S. Federal Specs: GGG-W-641E and Canadian Government Specs: CDA39-GP-12b and ANSI specifications

Universal Joints

PROD. NO.	MOD. NO.	Drive
670908	SA1407	1/4" x 1/4"
671910	SA3810	3/8" x 3/8"
672908	SA1207	1/2" x 1/2"

CrV

Socket Adapters

PROD. NO.	MOD. NO.	Male	Female
OPEN STOCK			
670911	SA1410	3/8"	1/4"
671913	SA3813	1/4"	3/8"
671914	SA3814	1/2"	3/8"
672911	SA1210	3/8"	1/2"
672912	SA1211	3/4"	1/2"
673907	SA7506	1/2"	3/4"
673912	SA7511	1/2"	3/4"

5 PC CHROME SOCKET ADAPTER SET

690115	SA-5S	3/8"	1/4"
		1/4"	3/8"
		1/2"	3/8"
		3/8"	1/2"
		3/4"	1/2"

CrV

Socket Clip Rails

- Includes one each for 1/4", 3/8", and 1/2" drive sockets

PROD. NO.	MOD. NO.	Drive	Clips
3 PC SOCKET CLIP RAIL SET			
690111	SCH-3S	1/4, 3/8, 1/2"	16 each (48 Total)

OPEN STOCK

670913	SCH-14	1/4"	16
671917	SCH-38	3/8"	16
672913	SCH-12	1/2"	16



670908



673912



672911

673907



690115



690111

WARNING: Do not use chrome sockets on impact wrenches



SOCKET ACCESSORIES

- All components are forged from high quality Chrome Vanadium steel
- Meets or exceeds U.S. Federal Specs: GGG-W-641E and Canadian Government Specs: CDA39-GP-12b and ANSI specifications

Flex Bars

PROD. NO.	MOD. NO.	Drive	Length	Max. Torque
670902	SA1401	1/4"	6"	35 ft/lb
671902	SA3801	3/8"	8"	100 ft/lb
672902	SA1201	1/2"	10"	330 ft/lb
672903	SA1202	1/2"	15"	330 ft/lb
672918	SA1213	1/2" *	24"	330 ft/lb
673909	SA7508	3/4" *	24"	750 ft/lb
673911	SA7510	3/4" **	-	750 ft/lb
674909	SA1008	1"	26"	1,850 ft/lb

Replacement repair kits listed in the back of the catalogue

- *672918 and 673909 features heavy duty head design
- **673911 comes with head only - requires drive handle



Extra strong CrMo gear components for professional use

Ratcheting Breaker Bars

- Swivel head breaker bar with 24 tooth ratchet action
- Use in neutral position to break fasteners free, then employ ratchet for fast removal of fastener
- Can also be used to apply greater torque than is possible with standard 1/2" drive ratchets
- Chrome Molybdenum and Chrome Vanadium construction for professional use
- Repair kit available (**900289**)

PROD. NO.	MOD. NO.	Drive	Length
672932	JRBB-18	1/2"	18"
672933	JRBB-24	1/2"	24"



WARNING: Do not use chrome sockets on impact wrenches

Speeder Handles

PROD. NO.	MOD. NO.	Drive	Length
671911	SA3811	3/8"	16"
672909	SA1208	1/2"	16-1/2"



Sliding T-Handles

PROD. NO.	MOD. NO.	Drive	Length
670907	SA1406	1/4"	4-1/4"
671909	SA3809	3/8"	8"
672907	SA1206	1/2"	10"
673906	SA7505	3/4"	18"
673910	SA7509	3/4" *	Head Only
674904	SA1003	1"	22"



*Requires drive handle (sold separately)

Spinner Handles

PROD. NO.	MOD. NO.	Drive	Length
670912	SA1411	1/4"	6"

T-Handle Spinner Wrenches

- Unique aluminum grip with bearings provides super smooth spinner action
- Adjustable grip can be used in 4 depth positions or removed for access to recessed areas
- Pull down locking collar keeps grip at desired location for most stable use
- 12" length reaches deep into engine bays and other confined spaces
- Chrome Vanadium steel for professional use
- Textured PVC coated T-handle for improved user comfort

3 PC T-Handle Spinner Wrench Set

- Comes in convenient EVA foam tool box organizer

PROD. NO.	MOD. NO.	Drive	Length	Pieces
690130	JSTH-3S	1/4, 3/8, 1/2"	12"	3

OPEN STOCK

670930	-	1/4"	12"	1
671930	-	3/8"	12"	1
672930	-	1/2"	12"	1



WARNING: Do not use chrome sockets on impact wrenches



671911



673910

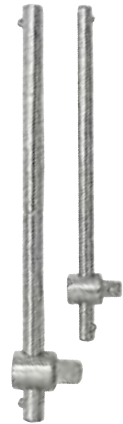

670907



670912



Grip adjust to 4 depth positions or can be removed entirely





690120



690121



672914

SOCKET ACCESSORIES

- All components are forged from high quality Chrome Vanadium steel
- Meets or exceeds U.S. Federal Specs: GGG-W-641E and Canadian Government Specs: CDA39-GP-12b and ANSI specifications

EXTENSION BARS

PROD. NO.	MOD. NO.	Pieces	Drive	Length
SETS				
690120	SE38-4S	4	3/8"	1-3/4, 3, 6, 10"
690121	SE12-3S	3	1/2"	2, 5, 10"
672914*	SE12-4S	4	1/2"	15, 18, 24, 30" (extra long)
* Not CrV Steel				
OPEN STOCK				
670904	SA1403	-	1/4"	2"
670905	SA1404	-	1/4"	3"
670915	SA1412	-	1/4"	4"
670906	SA1405	-	1/4"	6"
671904	SA1403	-	3/8"	1-3/4"
671905	SA3804	-	3/8"	3"
671907	SA3806	-	3/8"	6"
671908	SA3808	-	3/8"	10"
672904	SA1203	-	1/2"	2"
672905	SA1204	-	1/2"	5"
672906	SA1205	-	1/2"	10"
673903	SA7502	-	3/4"	4"
673904	SA7503	-	3/4"	8"
673905	SA7504	-	3/4"	16"
674903	SA1002	-	1"	16"
674905	SA1004	-	1"	8"

WARNING: Do not use chrome sockets on impact wrenches

Locking Extension Bars

- Sockets and accessories lock on and cannot be removed until lock ring is retracted
- Keeps everything from ratchet to the socket positively connected, preventing lost pieces
- Especially useful when multiple extensions must be used
- Ideal for use with JET's quick release ratchet handles
- Coloured lock rings help identify drive size - a JET exclusive!
- Highest quality Chrome Vanadium steel for professional use

PROD. NO.	MOD. NO.	Pieces	Drive	Length
SETS				
690124	SE38-3SL	3	3/8"	3, 6, 10"
690125	SE12-3SL	3	1/2"	3, 5, 10"

OPEN STOCK

671947	SA3804L	-	3/8"	3"
671948	SA3806L	-	3/8"	6"
671949	SA3808L	-	3/8"	10"
672947	SA1203L	-	1/2"	3"
672948	SA1204L	-	1/2"	5"
672949	SA1205L	-	1/2"	10"



690124



690125

WARNING: Do not use chrome sockets on impact wrenches



690122



690123

SOCKET ACCESSORIES

2 Way Wobble Extension Bars

- Two position extensions provide regular or wobble drive
- Place socket in first position for wobble drive; allows improved access to hard-to-reach areas
- Push socket down to second position to lock it solidly in place; allows maximum torque
- Each extension replaces two others but doesn't cost twice as much
- Highest quality Chrome Vanadium steel for professional use

PROD. NO.	MOD. NO.	Pieces	Drive	Length
-----------	----------	--------	-------	--------

SETS

690122	SE38-4SW	4	3/8"	1-3/4, 3, 6, 10"
690123	SE12-3SW	3	1/2"	2, 5, 10"

OPEN STOCK

671951	SA3803W	-	3/8"	1-3/4"
671952	SA3804W	-	3/8"	3"
671953	SA3806W	-	3/8"	6"
671954	SA3808W	-	3/8"	10"
672951	SA1203W	-	1/2"	2"
672952	SA1204W	-	1/2"	5"
672953	SA1205W	-	1/2"	10"

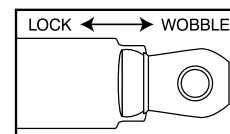

WARNING: Do not use chrome sockets on impact wrenches



IMPACT SOCKETS





TORQUE DRIVE®



3/8" DRIVE SOCKET SETS

- Sockets made of the finest quality SAE 4140 Chrome Molybdenum high impact steel
- TORQUE DRIVE® socket design contacts the fastener on the sides instead of the corners, reducing fastener rounding and allowing up to 20% more torque
- Chamfered edges allow easiest socket placement on fastener, increasing productivity and reducing frustration
- Extra long deep sockets ensure maximum accessibility
- Meets or exceeds U.S. Federal Specs: GGG-W-660A and ANSI specifications

8 PC SAE - 6 Point

610201 / PS838

STANDARD LENGTH SAE

5/16, 3/8, 7/16, 1/2, 9/16, 5/8, 11/16, 3/4"

- Blow mould case



8 PC Deep SAE - 6 Point

610203 / PS838D

DEEP LENGTH SAE

5/16, 3/8, 7/16, 1/2, 9/16, 5/8, 11/16, 3/4"

- Blow mould case



12 PC SAE - 6 Point

610207 / PS1238

STANDARD LENGTH SAE

5/16, 3/8, 7/16, 1/2, 9/16, 5/8, 11/16, 3/4, 13/16, 7/8, 15/16, 1"

- Blow mould case



12 PC Deep SAE - 6 Point

610208 / PS1238D

DEEP LENGTH SAE

5/16, 3/8, 7/16, 1/2, 9/16, 5/8, 11/16, 3/4, 13/16, 7/8, 15/16, 1"

- Blow mould case



13 PC Metric - 6 Point

610217 / PS1438M

STANDARD LENGTH METRIC

7, 8, 9, 10, 11, 12, 13, 14, 15, 16, 17, 18, 19 mm

- Blow mould case



13 PC Deep Metric - 6 Point

610218 / PS1338DM

DEEP LENGTH METRIC

7, 8, 9, 10, 11, 12, 13, 14, 15, 16, 17, 18, 19 mm

- Blow mould case



1/2" DRIVE SOCKET SETS



- Sockets made of the finest quality SAE 4140 Chrome Molybdenum high impact steel
- TORQUE DRIVE® socket design contacts the fastener on the sides instead of the corners, reducing fastener rounding and allowing up to 20% more torque
- Chamfered edges allow easiest socket placement on fastener, increasing productivity and reducing frustration
- Extra long deep sockets ensure maximum accessibility
- Meets or exceeds U.S. Federal Specs: GGG-W-660A and ANSI specifications

10 PC SAE - 6 Point

610302 / PS1012

STANDARD LENGTH SAE

7/16, 1/2, 9/16, 5/8, 11/16, 3/4, 13/16, 7/8, 15/16, 1"

- Blow mould case



TORQUE DRIVE®



10 PC Deep SAE - 6 Point

610303 / PS1012D

STANDARD LENGTH SAE

7/16, 1/2, 9/16, 5/8, 11/16, 3/4, 13/16, 7/8, 15/16, 1"

- Blow mould case



13 PC SAE - 6 Point

610321 / PS1312

STANDARD LENGTH SAE

7/16, 1/2, 9/16, 5/8, 11/16, 3/4, 13/16, 7/8, 15/16, 1, 1-1/16, 1-1/8, 1-1/4"

- Blow mould case



13 PC Deep SAE - 6 Point

610323 / PS1312D

DEEP LENGTH SAE

7/16, 1/2, 9/16, 5/8, 11/16, 3/4, 13/16, 7/8, 15/16, 1, 1-1/16, 1-1/8, 1-1/4"

- Blow mould case



19 PC SAE - 6 Point

610328 / PS1912

STANDARD LENGTH SAE

3/8, 7/16, 1/2, 9/16, 5/8, 11/16, 3/4, 13/16, 7/8, 15/16, 1, 1-1/16, 1-1/8, 1-3/16, 1-1/4, 1-5/16, 1-3/8, 1-7/16, 1-1/2"

- Blow mould case with removable lid



19 PC Deep SAE - 6 Point

610329 / PS1912D

DEEP LENGTH SAE

3/8, 7/16, 1/2, 9/16, 5/8, 11/16, 3/4, 13/16, 7/8, 15/16, 1, 1-1/16, 1-1/8, 1-3/16, 1-1/4, 1-5/16, 1-3/8, 1-7/16, 1-1/2"

- Blow mould case with removable lid





TORQUE DRIVE®



Jumbo Sizes



Jumbo Sizes



1/2" DRIVE SOCKET SETS

8 PC Jumbo SAE - 6 Point

610314 / PS812

STANDARD LENGTH SAE

1-9/16, 1-5/8, 1-11/16, 1-3/4, 1-13/16, 1-7/8, 1-15/16, 2"

- Blow mould case

6 CrMo

8 PC Jumbo Deep SAE - 6 Point

610315 / PS812D

DEEP LENGTH SAE

1-9/16, 1-5/8, 1-11/16, 1-3/4, 1-13/16, 1-7/8, 1-15/16, 2"

- Blow mould case with removable lid

6 CrMo

12 PC Metric - 6 Point

610308 / PS1212M

STANDARD LENGTH METRIC

10, 12, 13, 14, 15, 16, 17, 18, 19, 21, 22, 24 mm

- Blow mould case

6 CrMo

12 PC Deep Metric - 6 Point

610310 / PS1212DM

DEEP LENGTH METRIC

10, 12, 13, 14, 15, 16, 17, 18, 19, 21, 22, 24 mm

- Blow mould case

6 CrMo

TORQUE DRIVE



Jumbo Sizes



Jumbo Sizes



22 PC Metric - 6 Point 610338 / PS2212M

STANDARD LENGTH METRIC

10, 11, 12, 13, 14, 15, 16, 17, 18, 19, 20, 21, 22, 23, 24, 25,
26, 27, 28, 29, 30, 32 mm

- Blow mould case with removable lid



22 PC Deep Metric - 6 Point 610339 / PS2212DM

DEEP LENGTH METRIC

10, 11, 12, 13, 14, 15, 16, 17, 18, 19, 20, 21, 22, 23, 24, 25,
26, 27, 28, 29, 30, 32 mm

- Blow mould case with removable lid



12 PC Jumbo Metric - 6 Point 610334 / PS1212LM

STANDARD LENGTH METRIC

23, 24, 25, 26, 27, 28, 30, 32, 33, 34, 35, 36 mm

- Blow mould case



12 PC Jumbo Deep Metric - 6 Point 610335 / PS1212DLM

DEEP LENGTH METRIC

23, 24, 25, 26, 27, 28, 30, 32, 33, 34, 35, 36 mm

- Blow mould case with removable lid



22 PC Deep SAE/Metric - 6 Point 610327 / PS2712DC

DEEP LENGTH SAE

7/16, 1/2, 9/16, 5/8, 11/16, 3/4, 13/16, 7/8, 15/16, 1, 1-1/16, 1-1/8, 1-1/4"

DEEP LENGTH METRIC

10, 12, 13, 14, 15, 16, 17, 18, 19, 21, 22, 24 mm

STANDARD ACCESSORIES:

- 5" extension and 1" universal joint
- Blow mould case with removable lid





TORQUE DRIVE



610341

1/2" DRIVE UNIVERSAL SOCKET SETS

- Made from the best quality SAE 4140 Chrome Molybdenum high impact steel
- Heavy duty flexible joints allow easier access to fasteners in hard to reach areas
- Reinforcement ring ensures maximum strength

7 PC SAE Universal - 6 Point

610382 / PSU712

STANDARD LENGTH SAE

1/2, 9/16, 5/8, 11/16, 3/4, 13/16, 7/8"

- Blow mould case



9 PC Metric Universal - 6 Point

610388 / PSU912M

STANDARD LENGTH METRIC

13, 14, 15, 16, 17, 18, 19, 21, 22 mm

- Blow mould case



MAG WHEEL SOCKETS

- Specially designed for use on high end aluminum and chrome plated wheels
- Premium grade Chrome Molybdenum steel for professional use
- Plastic sleeve and inner cap to prevent scratches

1/2" DR Deep SAE/Metric Set

PROD. NO.	MOD. NO.	Drive	Pieces	Sizes
610341	MWPS-512	1/2"	5	13/16", 7/8", 17, 19 (3/4"), 21 mm

- Blow mould case



1/2" DR Deep - Open Stock

PROD. NO.	Drive	Sizes	Replacement Sleeve	Replacement Insert
682867	1/2"	17mm	682981	682991
682869	1/2"	19mm	682982	682992
682871	1/2"	21mm	682983	682993
682876	1/2"	13/16"	682985	682995
682878	1/2"	7/8"	682986	682996

- Specially designed Chrome Molybdenum spring steel flexes at preset torque ratings
- Allows accurate application of specific torque to automobile wheel fasteners
- Prevents over-tightening or uneven tightening of lug nuts, a major cause of wheel and brake rotor damage
- 5 extensions cover most passenger and light truck / SUV wheels
- For use with 1/2" drive impact wrenches rated at 250 ft/lb and line pressure of 90 – 110 PSI
- For aluminum and chrome wheels, use with JET's 1/2" drive Mag Wheel Power Sockets

TORQUE DRIVE®



5 PC 1/2" DR Set

PROD. NO.	MOD. NO.	Drive	Pieces	Torque (ft/lb)
682961	JTLE-5S	1/2"	5	65, 80, 100, 120, 140

- Blow mould case with removable lid

CrMo

1/2" DR - Open Stock

PROD. NO.	Drive	Torque (ft/lb)	Length	Colour
682964	1/2"	65	7-3/4"	Yellow
682965	1/2"	80	7-3/4"	Blue
682966	1/2"	100	7-3/4"	Gray
682967	1/2"	120	7-3/4"	White
682968	1/2"	140	7-3/4"	Aqua

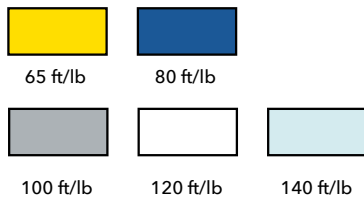



TORQUE DRIVE®



Jumbo Sizes



3/4" DRIVE SOCKET SETS

- Sockets made of the finest quality SAE 4140 Chrome Molybdenum high impact steel
- TORQUE DRIVE® socket design contacts the fastener on the sides instead of the corners, reducing fastener rounding and allowing up to 20% more torque
- Chamfered edges allow easiest socket placement on fastener, increasing productivity and reducing frustration
- Extra long deep sockets ensure maximum accessibility
- Most sets come with two-tone blow mould cases with removable lids for use as an organizer
- Meets or exceeds U.S. Federal Specs: GGG-W-660A and ANSI specifications

8 PC SAE - 6 Point

610401 / PS834

STANDARD LENGTH SAE

1, 1-1/16, 1-1/8, 1-1/4, 1-5/16, 1-3/8, 1-7/16, 1-1/2"

- Blow mould case



8 PC Deep SAE - 6 Point

610402 / PS834D

DEEP LENGTH SAE

1, 1-1/16, 1-1/8, 1-1/4, 1-5/16, 1-3/8, 1-7/16, 1-1/2"

- Blow mould case



8 PC Jumbo SAE - 6 Point

610404 / PS834L

STANDARD LENGTH SAE

2-1/16, 2-1/8, 2-3/16, 2-1/4, 2-5/16, 2-3/8, 2-7/16, 2-1/2"

- Blow mould case with removable lid



14 PC Deep SAE - 6 Point

610406 / PS1434D

DEEP LENGTH SAE

3/4, 13/16, 7/8, 15/16, 1, 1-1/16, 1-1/8, 1-3/16, 1-1/4, 1-5/16, 1-3/8, 1-7/16, 1-1/2, 1-5/8"

- Blow mould case with removable lid



16 PC SAE - 6 Point

610403 / PS1634

STANDARD LENGTH SAE

3/4, 13/16, 7/8, 15/16, 1, 1-1/16, 1-1/8, 1-1/4, 1-5/16, 1-3/8, 1-7/16, 1-1/2, 1-5/8, 1-3/4, 1-7/8, 2"

- Blow mould case with removable lid



3/4" DRIVE SOCKET SETS



17 PC Metric - 6 Point

610407 / PS1734M

STANDARD LENGTH METRIC

19, 21, 22, 23, 24, 26, 27, 29, 30, 32, 33, 35, 36, 38, 41, 46, 50 mm

- Blow mould case with removable lid



17 PC Deep Metric - 6 Point

610408 / PS1734DM

DEEP LENGTH METRIC

19, 21, 22, 23, 24, 26, 27, 29, 30, 32, 33, 35, 36, 38, 41, 46, 50 mm

- Blow mould case with removable lid



21 PC SAE - 6 Point

610409 / PS2134

STANDARD LENGTH SAE

3/4, 13/16, 7/8, 15/16, 1, 1-1/16, 1-1/8, 1-3/16, 1-1/4, 1-5/16, 1-3/8, 1-7/16, 1-1/2, 1-9/16, 1-5/8, 1-11/16, 1-3/4, 1-13/16, 1-7/8, 1-15/16, 2"

- Blow mould case with removable lid



21 PC Deep SAE - 6 Point

610410 / PS2134D

DEEP LENGTH SAE

3/4, 13/16, 7/8, 15/16, 1, 1-1/16, 1-1/8, 1-3/16, 1-1/4, 1-5/16, 1-3/8, 1-7/16, 1-1/2, 1-9/16, 1-5/8, 1-11/16, 1-3/4, 1-13/16, 1-7/8, 1-15/16, 2"

- Blow mould case with removable lid



1" DRIVE SOCKET SETS

9 PC SAE - 6 Point

610501 / PS901

STANDARD LENGTH SAE

1, 1-1/8, 1-1/4, 1-3/8, 1-1/2, 1-5/8, 1-3/4, 1-7/8, 2"

- Blow mould case with removable lid



TORQUE DRIVE



18 PC SAE - 6 Point

610509 / PS1801

STANDARD LENGTH SAE

3/4, 13/16, 7/8, 15/16, 1, 1-1/16, 1-1/8, 1-3/16, 1-1/4, 1-5/16, 1-3/8, 1-7/16, 1-1/2, 1-5/8, 1-3/4, 1-13/16, 1-7/8, 2"

- Blow mould case with removable lid





TORQUE DRIVE®



Jumbo Sizes



Jumbo Sizes



1" DRIVE SOCKET SETS

- Sockets made of the finest quality SAE 4140 Chrome Molybdenum high impact steel
- TORQUE DRIVE® socket design contacts the fastener on the sides instead of the corners, reducing fastener rounding and allowing up to 20% more torque
- Chamfered edges allow easiest socket placement on fastener, increasing productivity and reducing frustration
- Extra long deep sockets ensure maximum accessibility
- Most sets come with two-tone blow mould case with removable lid for use as an organizer
- Meets or exceeds U.S. Federal Specs: GGG-W-660A and ANSI specifications

9 PC Deep SAE - 6 Point

610503 / PS901D

DEEP LENGTH SAE

1, 1-1/8, 1-1/4, 1-3/8, 1-1/2, 1-5/8, 1-3/4, 1-7/8, 2"

- Blow mould case with removable lid

6 CrMo

11 PC Jumbo Deep SAE - 6 Point

610504 / PS1101D

DEEP LENGTH SAE

2-1/16, 2-1/8, 2-3/16, 2-1/4, 2-5/16, 2-3/8, 2-7/16, 2-1/2,
2-9/16, 2-5/8, 2-3/4"

- Blow mould case with removable lid

6 CrMo

12 PC Jumbo SAE - 6 Point

610506 / PS1201

STANDARD LENGTH SAE

2-1/8, 2-1/4, 2-3/8, 2-1/2, 2-9/16, 2-5/8, 2-3/4, 2-7/8, 3, 3-1/8,
3-1/4, 3-1/2"

- Blow mould case with removable lid

6 CrMo

16 PC Deep SAE - 6 Point

610508 / PS1601D

DEEP LENGTH SAE

7/8, 15/16, 1, 1-1/16, 1-1/8, 1-3/16, 1-1/4, 1-5/16, 1-3/8, 1-7/16, 1-1/2, 1-5/8,
1-3/4, 1-13/16, 1-7/8, 2"

- Blow mould case with removable lid

6 CrMo

1" DRIVE TRUCK TIRE SOCKET SETS



- Made of highest quality SAE 4140 Chrome Molybdenum steel for maximum strength and durability
- Special sizes designed for use on most truck wheel fasteners

11 PC SAE/Metric

- 11 of the most popular SAE and Metric sizes for heavy trucks
- 4 point sockets for inner Budd-style square fasteners
- Special 1-1/2" hex deep socket features controlled depth, preventing contact with inner cap nut
- Deep thin wall sockets designed for use on Dayton style lugnuts where space is limited
- Blow mould case with removable lid

PROD. NO.	MOD. NO.	4 Point Shallow Budd Sockets	6 Point Deep Budd Sockets	6 Point Thin Wall Sockets
610515	TTPS-11SM	17 mm, 21 mm, 13/16"	33 mm, 35 mm, 38 mm, 41 mm, 1-1/2" controlled depth	1-1/16", 1-1/8", -1/4"

CrMo



610515

1" DRIVE TRUCK TIRE - OPEN STOCK

Budd Wheel Type - 4 Point

- Designed for use on inner budd-style square fasteners

PROD. NO.	Size	Length
684921	13/16"	57 mm
684922	15/16"	57 mm
684971	17mm	57 mm
684975	21mm	57 mm



684922

684622

Budd Wheel Type - 6 Point

- For use on most import and some domestic trucks
- 1-1/2" hex socket features controlled depth, preventing contact with wheel when removing outer cap nuts

PROD. NO.	Size	Length
684614	33 mm	98 mm
684616	35 mm	98 mm
684619	38 mm	98 mm
684622	41 mm	98 mm
684966	1-1/2" controlled depth	98 mm



684966

Extra Thin Wall Type - 6 Point Deep

- For use on Dayton-style lugnuts that are deeply recessed and where space is limited
- Extra thin wall sockets are not a warrantable item

PROD. NO.	Size	Length
684943	1-1/16"	108 mm
684944	1-1/8"	108 mm
684946	1-1/4"	108 mm



Extra Thin Wall

684946



1/2" DRIVE TORX® BIT SOCKET SETS

- Made of SNCM 8660 tool steel for 20% greater torque and 20% greater torsional resistance than regular Chrome Molybdenum bits
- Manganese Phosphate finish

10 PC - TORX®

610326 / PTB1210

3" OVERALL LENGTH TORX®

T25, T27, T30, T40, T45, T50, T55, T60, T70, T80

- Blow mould case



1/2" DRIVE HEX BIT SOCKET SETS

8 PC SAE - Hex

610331 / PHB-1208

3" OVERALL LENGTH SAE

1/4, 5/16, 3/8, 7/16, 1/2, 9/16, 5/8, 3/4"

- Blow mould case



8 PC Metric - Hex

610333 / PHB1208M

3" OVERALL LENGTH METRIC

6, 7, 8, 10, 12, 14, 17, 19 mm

- Blow mould case



16 PC SAE/Metric - Hex

610340 / PHB-1216C

3" OVERALL LENGTH SAE

1/4, 5/16, 3/8, 7/16, 1/2, 9/16, 5/8, 3/4"

3" OVERALL LENGTH METRIC

6, 7, 8, 10, 12, 14, 17, 19 mm

- Set contains all popular sizes of hex bit power sockets!
- Blow mould case



3/4" DRIVE HEX BIT SOCKET SETS



- Made of SNCM 8660 tool steel for 20% greater torque and 20% greater torsional resistance than regular Chrome Molybdenum bits
- Manganese Phosphate finish

5 PC SAE - Hex

610411 / PHB-3405

3" OVERALL LENGTH SAE

5/8, 3/4, 7/8, 1, 1-1/4"

- Blow mould case with removable lid



5 PC Metric - Hex

610421 / PHB3405M

3" OVERALL LENGTH METRIC

17, 19, 22, 24, 27 mm

- Blow mould case with removable lid



3/8" & 1/2" DRIVE EXTERNAL TORX® SETS

- Sockets made of the finest quality SAE 4140 Chrome Molybdenum high impact steel
- Set features the full range of popular external TORX® sizes
- Convenient blow mould case keeps sockets organized

17 PC - External TORX®

610391 / PTS-17C

STANDARD LENGTH E-TORX® POWER SOCKETS:

- 3/8" Drive Sockets: **E5, E6, E7, E8, E10, E12, E14, E16**
- 1/2" Drive Sockets: **E10, E11, E12, E14, E16, E18, E20, E22, E24**
- Blow mould case





SOCKET ACCESSORIES

- Sockets made of the finest quality SAE 4140 Chrome Molybdenum high impact steel
- Meets or exceeds U.S. Federal Specs: GGG-W-660A and ANSI specifications



610903



610906



682939



682954

Accessory Kits

- Blow mould case keeps all items organized and handy
- A great addition to any mechanics tool box

PROD. NO.	MOD. NO.	Description	Contains
610903	PSA3812-7	7 PC Impact Accessory Kit	3/8" dr. x 6" extension 3/8" dr. U Joint 3/8" F x 1/2" M adapter 1/2" dr. x 5" extension 1/2" U Joint 1/2" F x 3/8" M adapter 1/2" F x 3/4" M adapter
610906	PSA3401-5	5 PC Impact Accessory Kit	3/4" dr. U Joint 1" dr. U Joint 3/4" F x 1/2" M adapter 3/4" F x 1" M adapter 1" F x 3/4" M adapter



1/2" Drive Extra Thin Wall Flip Sockets

- Extra thin walls allows access to all recessed lugnuts where clearance is limited
- Thin wall impact sockets not a warrantable item

PROD. NO.	Length	Size
682938	76mm	3/4 x 13/16" hex
682939	76mm	19 x 21mm hex



Extension Bars

PROD. NO.	Length	Drive
681953	3"	3/8"
681954	6"	3/8"
682954	5"	1/2"
682955	10"	1/2"
683951	6"	3/4"
683953	10"	3/4"
684951	6"	1"



Socket Adapters

- Socket adapters do not carry lifetime warranty

PROD. NO.	Drive Female	Drive Male
681952	3/8"	1/2"
682952	1/2"	3/8"
682953	1/2"	3/4"
683952	3/4"	1/2"
683954	3/4"	1"
684952	1"	3/4"



681952

Pin Free Impact Locking U-Joints

- Patented hex ball and socket design eliminates connecting pin for increased safety
- Ball and socket distributes force evenly for greater torque and longer life
- Eliminates broken connecting pins, the major source of U joint failures
- Drive anvil locks into straight position when flex function is not required
- Can be left on impact wrench and engaged only when needed



PROD. NO.	MOD. NO.	Drive Female & Male
-----------	----------	---------------------

3 PIECE SET

610901	PLUJ-3S	1/4, 3/8, 1/2"
--------	---------	----------------

OPEN STOCK

680915	PLUJ-1414	1/4"
681915	PLUJ-3838	3/8"
682915	PLUJ-1212	1/2"



610901
3 Piece Set

Pin Free Impact U-Joints Adapters

- Patented hex ball and socket design eliminates connecting pin for increased safety
- U-Joint adapters do not carry lifetime warranty



PROD. NO.	MOD. NO.	Drive Female	Drive Male
-----------	----------	--------------	------------

5 PIECE SET

610902	PLUJ-5S	See Below	
--------	---------	-----------	--

OPEN STOCK

680918	PLUJ-1438	1/4"	3/8"
681917	PLUJ-3814	3/8"	1/4"
681918	PLUJ-3812	3/8"	1/2"
682917	PLUJ-1238	1/2"	3/8"
682918	PLUJ-1234	1/2"	3/4"



610902
5 Piece Set

Universal Joints

PROD. NO.	Drive Female	Drive Male
681911	3/8"	3/8"
682911	1/2"	1/2"
683955	3/4"	3/4"
684955	1"	1"



682911

683955



SAE OPEN STOCK

- Sockets made of the finest quality SAE 4140 Chrome Molybdenum high impact steel
- Meets or exceeds U.S. Federal Specs: GGG-W-660A and ANSI specifications



Drive	3/4"	1"	1"
Size SAE	Regular 6 pt.	Regular 6 pt.	Deep 6 pt.
2-1/16"	683166	684165	684266
2-1/8"	683168	684166	684268
2-3/16"	683170	684167	684270
2-1/4"	683172	684168	684272
2-5/16"	683174	684169	684274
2-3/8"	683176	684170	684276
2-7/16"	683178	684171	684278
2-1/2"	683180	684172	684280
2-9/16"		684173	684282
2-5/8"		684174	684284
2-11/16"		684175	
2-3/4"		684176	684288
2-13/16"		684177	
2-7/8"		684178	
2-15/16"		684179	
3"		684180	
3-1/8"		684182	
3-1/4"		684184	
3-3/8"		684186	
3-1/2"		684188	
3-5/8"		684190	
3-3/4"		684192	
3-7/8"		684194	
4"		684196	
4-1/8"		684197	
4-1/4"		684198	
4-1/2"		684199	

Drive	3/8"	3/8"	1/2"	1/2"	1/2"	3/4"	3/4"	1"	1"
Size SAE	Regular 6 pt.	Deep 6 pt.	Regular 6 pt.	Deep 6 pt.	Universal Regular 6pt.	Regular 6 pt.	Deep 6 pt.	Regular 6 pt.	Deep 6 pt.
5/16"	681110	681210							
3/8"	681112	681212	682112	682212					
7/16"	681114	681214	682114	682214					
1/2"	681116	681216	682116	682216	682316				
9/16"	681118	681218	682118	682218	682318				
5/8"	681120	681220	682120	682220	682320				
11/16"	681122	681222	682122	682222	682322				
3/4"	681124	681224	682124	682224	682324	683124	683224	684124	
13/16"	681126	681226	682126	682226	682326	683126	683226	684126	
7/8"	681128	681228	682128	682228	682328	683128	683228	684128	684228
15/16"	681130	681230	682130	682230		683130	683230	684130	684230
1"	681132	681232	682132	682232		683132	683232	684132	684232
1-1/16"			682134	682234		683134	683234	684134	684234
1-1/8"			682136	682236		683136	683236	684136	684236
1-3/16"			682138	682238		683138	683238	684138	684238
1-1/4"			682140	682240		683140	683240	684140	684240
1-5/16"			682142	682242		683142	683242	684142	684242
1-3/8"			682144	682244		683144	683244	684144	684244
1-7/16"			682146	682246		683146	683246	684146	684246
1-1/2"			682148	682248		683148	683248	684148	684248
1-9/16"			682150	682250		683150	683250	684150	684250
1-5/8"			682152	682252		683152	683252	684152	684252
1-11/16"			682154	682254		683154	683254	684154	684254
1-3/4"			682156	682256		683156	683256	684156	684256
1-13/16"			682158	682258		683158	683258	684158	684258
1-7/8"			682160	682260		683160	683260	684160	684260
1-15/16"			682162	682262		683162	683262	684162	684262
2"			682164	682264		683164	683264	684164	684264

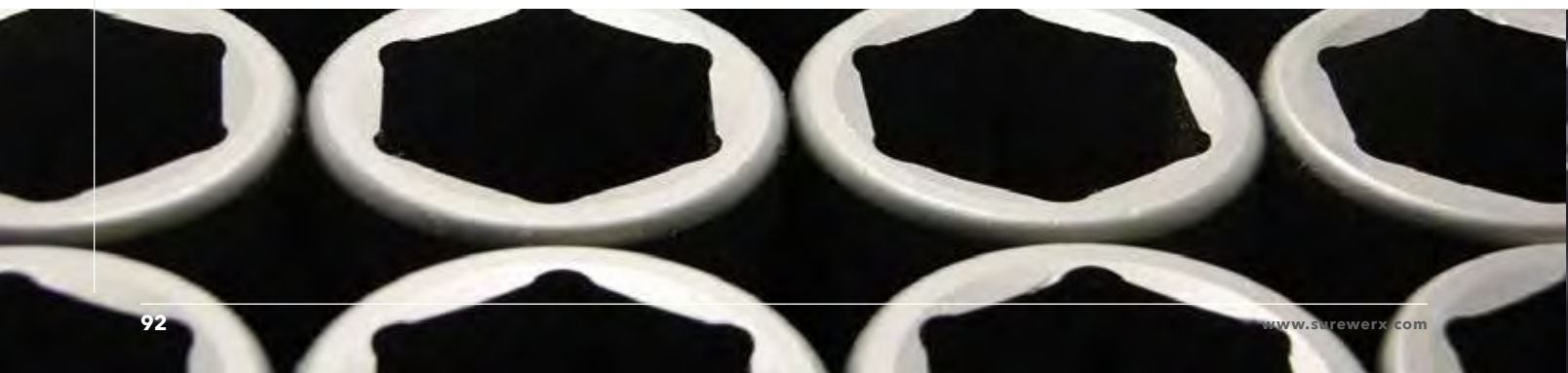

- Sockets made of the finest quality 4140 Chrome Molybdenum high impact steel
- Meets or exceeds U.S. Federal Specs: GGG-W-660A and ANSI specifications

6 CrMo

Drive	3/8"	3/8"	1/2"	1/2"	1/2"	3/4"	3/4"
Metric (mm)	Regular 6 pt.	Deep 6 pt.	Regular 6 pt.	Deep 6 pt.	Universal Regular 6 pt.	Regular 6 pt.	Deep 6 pt.
7 mm	681507	681607					
8 mm	681508	681608					
9 mm	681509	681609					
10 mm	681510	681610	682510	682610			
11 mm	681511	681611	682511	682611			
12 mm	681512	681612	682512	682612			
13 mm	681513	681613	682513	682613	682713		
14 mm	681514	681614	682514	682614	682714		
15 mm	681515	681615	682515	682615	682715		
16 mm	681516	681616	682516	682616	682716		
17 mm	681517	681617	682517	682617	682717		
18 mm	681518	681618	682518	682618	682718		
19 mm	681519	681619	682519	682619	682719	683519	683619
20 mm			682520	682620			
21 mm			682521	682621	682721	683521	683621
22 mm			682522	682622	682722	683522	683622
23 mm			682523	682623		683523	683623
24 mm			682524	682624		683524	683624
25 mm			682525	682625			
26 mm			682526	682626		683526	683626
27 mm			682527	682627		683527	683627
28 mm			682528	682628			
29 mm			682529	682629		683529	683629
30 mm			682530	682630		683530	683630
32 mm			682532	682632		683532	683632
33 mm			682533	682633		683533	683633
34 mm			682534	682634			
35 mm			682535	682635		683535	683635
36 mm			682536	682636		683536	683636
38 mm						683538	683638
41 mm						683541	683641
46 mm						683546	683646
50 mm						683550	683650





HEX AND TORX® BITS OPEN STOCK

- Made with premium quality SNCM8660 tool steel for 20% greater torsional resistance than Chrome Molybdenum bits



Drive	1/2"	3/4"
Hex Bits	3" Length Hex Bit	3-1/2" Length Hex Bit
1/4"	687211	
5/16"	687212	
3/8"	687213	
7/16"	687214	
1/2"	687215	
9/16"	687216	
5/8"	687217	687320
3/4"	687219	687324
7/8"		687328
1"		687332
1-1/4"		687340
6mm	687261	
7mm	687262	
8mm	687263	
10mm	687265	
12mm	687267	
14mm	687269	
17mm	687272	687367
19mm	687274	687369
22mm		687372
24mm		687374
27mm		687377

Drive	3/8"	1/2"	1/2"
TORX® Bits	External Torx® Socket	External Torx® Socket	3" Length Torx® Bit
E5	688055		
E6	688056		
E7	688057		
E8	688058		
E10	688060	688110	
E11		688111	
E12	688062	688112	
E14	688064	688114	
E16	688066	688116	
E18		688118	
E20		688120	
E22		688122	
E24		688124	
T25			687821
T27			687822
T30			687823
T40			687825
T45			687826
T50			687827
T55			687828
T60			687829
T70			687831
T80			687833

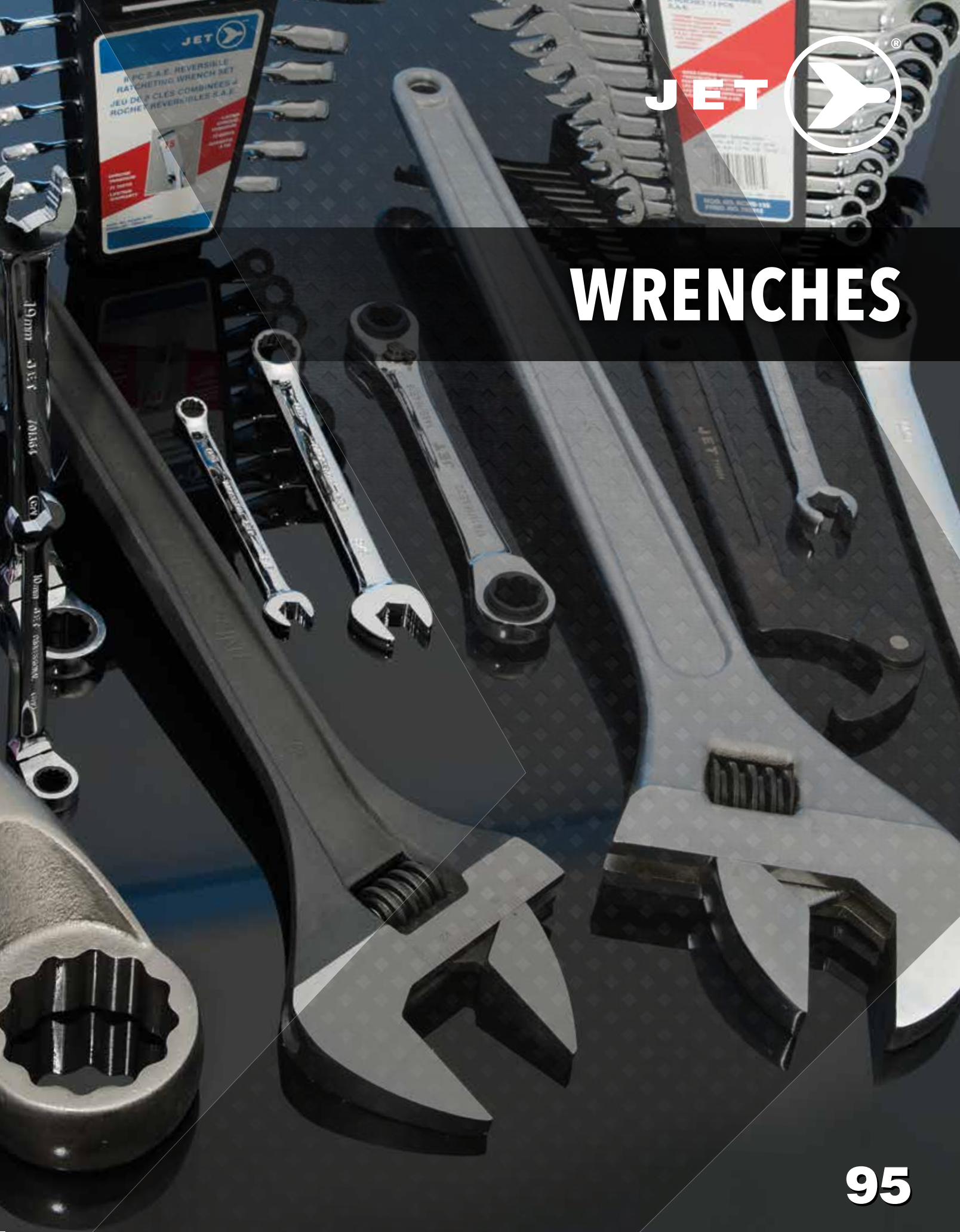

WRENCHES



TORQUE DRIVE



700110



700115



700121



700177



700201

COMBINATION WRENCHES - RAISED PANEL

- JET raised panel combination wrenches are made with industrial quality SAE 6140 Chrome Vanadium steel (up to 1-1/4" or 32 mm sizes)
- All wrenches feature TORQUE DRIVE® box ends for increased torque
- Wrench size stamped on head for easy identification
- Sets are supplied with industrial strength terylene pouches (except 700201)
- All sets meet ANSI specifications

SAE Wrench Sets

PROD. NO.	MOD. NO.	Pieces (total)	Size
700110	CWS-6S	6	3/8, 7/16, 1/2, 9/16, 5/8, 3/4" Terylene Pouch
700115	CWS-11S	11	3/8, 7/16, 1/2, 9/16, 5/8, 11/16, 3/4, 13/16, 7/8, 15/16, 1", Terylene Pouch
700121	CWS-16S	16	1/4, 5/16, 3/8, 7/16, 1/2, 9/16, 5/8, 11/16, 3/4, 13/16, 7/8, 15/16, 1, 1-1/16, 1-1/8, 1-1/4", Terylene Pouch

CrV

Metric Wrench Sets

PROD. NO.	MOD. NO.	Pieces (total)	Size
700167	CWS-11M	11	8, 9, 10, 11, 12, 13, 14, 15, 17, 18, 19 mm Terylene Pouch
700173	CWS-16M	16	7, 8, 9, 10, 11, 12, 13, 14, 15, 16, 17, 18, 19, 21, 22, 24mm, Terylene Pouch
700177	CWS-22M	22	7, 8, 9, 10, 11, 12, 13, 14, 15, 16, 17, 18, 19, 20, 21, 22, 23, 24, 26, 27, 30, 32 mm Terylene Pouch

CrV

SAE/Metric Wrench Sets

PROD. NO.	MOD. NO.	Pieces (total)	Size
700201	CWS-32SM	32	1/4, 5/16, 3/8, 7/16, 1/2, 9/16, 5/8, 11/16, 3/4, 13/16, 7/8, 15/16, 1, 1-1/16, 1-1/8, 1-1/4" 7, 8, 9, 10, 11, 12, 13, 14, 15, 16, 17, 18, 19, 21, 22, 24 mm

- Blow mould case

CrV



Size stamped on both sides for quick identification (up to 1-1/4" / 32 mm)

Box end features TORQUE DRIVE® pattern for increased torque

SAE Jumbo Wrench Sets

- JET jumbo wrenches are made with industrial quality S45C Alloy Steel
- Extra heavy drop forgings and premium curved shaft edges ensure maximum strength and comfort
- Not available with TORQUE DRIVE®

PROD. NO.	MOD. NO.	Pieces (total)	Size
700125	JCW-6	6	1-3/8, 1-1/2, 1-5/8, 1-3/4, 1-7/8, 2"
700128	JCW-10-2	10	1-5/16, 1-3/8, 1-7/16, 1-1/2, 1-5/8, 1-11/16, 1-3/4, 1-13/16, 1-7/8, 2"



700128



700521

SAE Wrenches - Open Stock

- SAE 6140 CrV steel

PROD. NO.	Size
700501	1/4"
700502	5/16"
700503	3/8"
700504	7/16"
700505	1/2"
700506	9/16"
700507	5/8"
700508	11/16"
700509	3/4"
700510	13/16"
700511	7/8"
700512	15/16"
700513	1"
700514	1-1/16"
700515	1-1/8"
700517	1-1/4"



SAE Jumbo Wrenches - Open Stock

- S45C alloy steel

PROD. NO.	Size
700518	1-5/16"
700519	1-3/8"
700520	1-7/16"
700521	1-1/2"
700523	1-5/8"
700524	1-11/16"
700525	1-3/4"
700526	1-13/16"
700527	1-7/8"
700529	2"
700531	2-1/8"
700533	2-1/4"
700535	2-3/8"
700537	2-1/2"

Metric Wrenches - Open Stock

- SAE 6140 CrV steel

PROD. NO.	Size
700552	7 mm
700553	8 mm
700554	9 mm
700555	10 mm
700556	11 mm
700557	12 mm
700558	13 mm
700559	14 mm
700560	15 mm
700561	16 mm
700562	17 mm
700563	18 mm
700564	19 mm
700565	20 mm
700566	21 mm
700567	22 mm
700568	23 mm
700569	24 mm
700571	26 mm
700572	27 mm
700575	30 mm
700577	32 mm





TORQUE DRIVE®



700134



700132



700182



700185



700136



700186

COMBINATION WRENCHES - FULLY POLISHED

- Exclusive TORQUE DRIVE® non-slip open ends
- Extra long pattern design allows greater torque and improved access to hard to reach areas
- Super strong SAE 6140 Chrome Vanadium steel for strength and durability
- 15° offset - optimal for most applications
- Fully polished mirror finish
- Extra slim design allows access to the most confined spaces
- All wrenches meet ASME and ANSI specifications

Long Pattern SAE Wrench Sets

PROD. NO.	MOD. NO.	Pieces (total)	Size
700132	LCWS-11S	11	1/4, 5/16, 3/8, 7/16, 1/2, 9/16, 5/8, 11/16, 3/4, 13/16, 7/8" Plastic Rack
700134	LCWS-14S	14	3/8, 7/16, 1/2, 9/16, 5/8, 11/16, 3/4, 13/16, 7/8, 15/16, 1, 1-1/16, 1-1/8, 1-1/4" Terylene Pouch

CrV

Long Pattern Metric Wrench Sets

PROD. NO.	MOD. NO.	Pieces (total)	Size
700182	LCWS-11M	11	8, 9, 10, 11, 12, 13, 14, 15, 17, 18, 19 mm Plastic Rack
700185	LCWS-16M	16	7, 8, 9, 10, 11, 12, 13, 14, 15, 16, 17, 18, 19, 21, 22, 24 mm Terylene Pouch

CrV

Extra Long Pattern - Sets

- Same quality features as shown above
- Extra length for hard-to-reach fasteners and greater torque

PROD. NO.	MOD. NO.	Pieces (total)	Size
700136	LCWS-11XLS	11	1/4, 5/16, 3/8, 7/16, 1/2, 9/16, 5/8, 11/16, 3/4, 13/16, 7/8" Plastic Rack
700186	LCWS-11XLM	11	8, 9, 10, 11, 12, 13, 14, 15, 17, 18, 19 mm Plastic Rack

CrV

Long Pattern Wrenches - Open Stock

SAE	
PROD. NO.	Size
700621	1/4"
700622	5/16"
700623	3/8"
700624	7/16"
700625	1/2"
700626	9/16"
700627	5/8"
700628	11/16"
700629	3/4"
700630	13/16"
700631	7/8"
700632	15/16"
700633	1"
700634	1-1/16"
700635	1-1/8"
700637	1-1/4"



Long Pattern Wrenches - Open Stock

METRIC	
PROD. NO.	Size
700672	7 mm
700673	8 mm
700674	9 mm
700675	10 mm
700676	11 mm
700677	12 mm
700678	13 mm
700679	14 mm
700680	15 mm
700681	16 mm
700682	17 mm
700683	18 mm
700684	19 mm
700685	20 mm
700686	21 mm
700687	22 mm
700688	23 mm
700689	24 mm



Extra Long Pattern SAE - Open Stock

SAE	
PROD. NO.	Size
700801	1/4"
700802	5/16"
700803	3/8"
700804	7/16"
700805	1/2"
700806	9/16"
700807	5/8"
700808	11/16"
700809	3/4"
700810	13/16"
700811	7/8"

Extra Long Pattern Metric - Open Stock

METRIC	
PROD. NO.	Size
700853	8 mm
700854	9 mm
700855	10 mm
700856	11 mm
700857	12 mm
700858	13 mm
700859	14 mm
700860	15 mm
700862	17 mm
700863	18 mm
700864	19 mm



Non-slip open ends in series:

FULLY POLISHED COMBINATION WRENCHES

EXTRA LONG FULLY POLISHED COMBINATION WRENCHES

All wrenches feature **TORQUE DRIVE®** box ends for increased torque

Exclusive "non-slip" open ends for increased torque and use on rounded fasteners





COMBINATION WRENCHES - MULTI-FIT



- Multi-fit box end fits SAE and Metric 6 pt. hex and 12 pt. double hex fasteners, as well as 4 pt. Spline and TORX® fasteners
- Patented open end fits SAE and Metric 6 pt. hex and 4 pt. square fasteners
- Permits use on fasteners when box end cannot be slipped over rod or bolt
- Competing open end designs require the user to purchase separate SAE and Metric sets
- 8 PC set fits 63 different sizes and types of fasteners providing unparalleled versatility
- Super strong SAE 6140 Chrome Vanadium steel for strength and durability
- 15° offset – ideal for most applications
- Fully polished mirror finish with 3 layers of plating for superior corrosion resistance

8 PC Multi-Fit Combination Wrench Sets

PROD. NO.	MOD. NO.	Pieces (total)	Size
700212	CWMF-8S	8	See below



Multi-Fit - Open Stock

BOX END FITS:	6 & 12 pt SAE	6 & 12 pt Metric	4 pt SAE	4 pt Metric	Spline	TORX®
700453	5/16	8	9/32	7	8	E10
700455	3/8	10	11/32	-	10	E12
700456	7/16	11	3/8	9	11	E14
700458	1/2	13	7/16	11	13	E16
700459	9/16	14	15/32	12	14	E18
700461	5/8	16	17/32	13	16	E20
700462	11/16	17	9/16	14	17	E22
700464	3/4	19	5/8	16	19	E24

OPEN END FITS:	6 pt SAE	6 pt Metric	4 pt SAE	4 pt Metric
700453	5/16	8	5/16	8
700455	3/8	10	3/8	10
700456	7/16	11	7/16	11
700458	1/2	13	1/2	13
700459	9/16	14	9/16	14
700461	5/8	16	5/8	16
700462	11/16	17	11/16	17
700464	3/4	19	3/4	18



- Extra short pattern style allows you to access confined areas
- Fully polished for clean professional look and feel
- 12 point TORQUE DRIVE® box end applies force to sides of fasteners, reducing corner rounding and allowing 20% more torque
- 15° offset is optimal for most applications
- Heavy duty drop forged SAE 6140 Chrome Vanadium steel made for professionals
- Meets ANSI Standards

TORQUE DRIVE®

Stubby SAE Wrench Set

PROD. NO.	MOD. NO.	Pieces (total)	Size
700141	SCWS-7S	7	3/8, 7/16, 1/2, 9/16, 5/8, 11/16, 3/4" Plastic Rack

CrV

Stubby Metric Combination Wrench Set

PROD. NO.	MOD. NO.	Pieces (total)	Size
700191	SCWS-7M	7	10, 12, 13, 15, 17, 18, 19 mm Plastic rack

CrV



700141



700191

Stubby SAE Wrenches - Open Stock

PROD. NO.	Size
700703	3/8"
700704	7/16"
700705	1/2"
700706	9/16"
700707	5/8"
700708	11/16"
700709	3/4"

Stubby Metric Wrenches - Open Stock

PROD. NO.	Size
700755	10 mm
700757	12 mm
700758	13 mm
700760	15 mm
700762	17 mm
700763	18 mm
700764	19 mm

CrV





TORQUE DRIVE®



700308



700312



700164



700361

RATCHET WRENCHES - SETS

- Exclusive TORQUE DRIVE® non-slip open ends & 12 point box ends for superior grip
- 72 tooth ratchet mechanism exceeds the ANSI torque ratings for a fixed wrench by more than 30%
- Superior grade 6140 Chrome Vanadium steel
- Flat style allows maximum access to confined areas - just flip wrench over to reverse
- Fully polished surface resists corrosion
- Complete with plastic carrying rack

Non-Reversing



Flip wrench to reverse direction

Long Pattern SAE Wrench Sets - Non Reversing

PROD. NO.	MOD. NO.	Pieces (total)	Size
700308	RCWS-8S	8	5/16, 3/8, 7/16, 1/2, 9/16, 5/8, 11/16, 3/4"
700312	RCWS-13S	13	1/4, 5/16, 3/8, 7/16, 1/2, 9/16, 5/8, 11/16, 3/4, 13/16, 7/8, 15/16, 1"

CrV

Long Pattern Metric Wrench Sets - Non Reversing

PROD. NO.	MOD. NO.	Pieces (total)	Size
700164	RCWS-7M	7	8, 10, 12, 13, 14, 15, 18 mm
700361	RCWS-12M	12	8, 9, 10, 11, 12, 13, 14, 15, 16, 17, 18, 19 mm

CrV



All professional wrenches in this category feature exclusive "non-slip" open ends for increased torque and use on rounded fasteners

- Same great features as flat style, but with reversing lever
- Allows 15° offset for clearance
- Low profile lever does not add height to the box end, maintaining clearance
- Rated at 1.2 x ANSI torque values

Reversing



700321



700322



700371



700372

Long Pattern SAE Wrench Sets - Reversing

PROD. NO.	MOD. NO.	Pieces (total)	Size
700321	RCWS-8SR	8	5/16, 3/8, 7/16, 1/2, 9/16, 5/8, 11/16, 3/4"
700322	RCWS-13SR	13	1/4, 5/16, 3/8, 7/16, 1/2, 9/16, 5/8, 11/16, 3/4, 13/16, 7/8, 15/16, 1"

CrV

Long Pattern Metric Wrench Sets - Reversing

PROD. NO.	MOD. NO.	Pieces (total)	Size
700371	RCWS-7MR	7	8, 10, 12, 13, 14, 15, 18 mm
700372	RCWS-12MR	12	8, 9, 10, 11, 12, 13, 14, 15, 16, 17, 18, 19 mm

CrV

JET Ratchet Wrenches Other Leading Brand

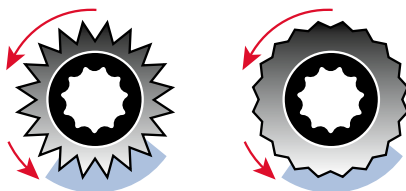

JET's deeper broached teeth allow greater torque loads and ensure positive tooth engagement



TORQUE DRIVE®

RATCHET WRENCHES - SETS

- Exclusive TORQUE DRIVE® non-slip open ends & 12 point box ends for superior grip
- 72 tooth ratchet mechanism exceeds the ANSI torque ratings for a fixed wrench by more than 30%
- Superior grade 6140 Chrome Vanadium steel
- Flat style allows maximum access to confined areas - just flip wrench over to reverse
- Fully polished surface resists corrosion
- Complete with plastic carrying rack



700336



700386



Extra long pattern ratcheting wrench is up to 25% longer than traditional wrenches

Extra Long Pattern Wrench - Sets

PROD. NO.	MOD. NO.	Pieces (total)	Size
700336	RCWS-9XLS	9	1/4, 5/16, 3/8, 7/16, 1/2, 9/16, 5/8, 11/16, 3/4"
700386	RCWS-12XLM	12	8, 9, 10, 11, 12, 13, 14, 15, 16, 17, 18, 19mm



700331

700381

Long Pattern Flex Head Wrench - Sets

- Flex head design allows up to 180° flex for increased access to confined areas
- Light tension holds position while allowing easy adjustment of angle

PROD. NO.	MOD. NO.	Pieces (total)	Size
700331	RCWS-11FS	11	1/4, 5/16, 3/8, 7/16, 1/2, 9/16, 5/8, 11/16, 3/4, 13/16, 7/8"
700381	RCWS-11FM	11	8, 9, 10, 11, 12, 13, 14, 15, 17, 18, 19mm



Flex head design 180° swing



SAE Open Stock - Non Reversing

PROD. NO.	Size	PROD. NO.	Size
701101	1/4"	701108	11/16"
701102	5/16"	701109	3/4"
701103	3/8"	701110	13/16"
701104	7/16"	701111	7/8"
701105	1/2"	701112	15/16"
701106	9/16"	701113	1"
701107	5/8"		

Metric Open Stock - Non Reversing

PROD. NO.	Size	PROD. NO.	Size
701153	8 mm	701159	14 mm
701154	9 mm	701160	15 mm
701155	10 mm	701161	16 mm
701156	11 mm	701162	17 mm
701157	12 mm	701163	18 mm
701158	13 mm	701164	19 mm



SAE Extra Long Open Stock - Non Reversing

PROD. NO.	Size	PROD. NO.	Size
701201	1/4"	701206	9/16"
701202	5/16"	701207	5/8"
701203	3/8"	701208	11/16"
701204	7/16"	701209	3/4"
701205	1/2"		

Metric Extra Long Open Stock - Non Reversing

PROD. NO.	Size	PROD. NO.	Size
701253	8 mm	701259	14 mm
701254	9 mm	701260	15 mm
701255	10 mm	701261	16 mm
701256	11 mm	701262	17 mm
701257	12 mm	701263	18 mm
701258	13 mm	701264	19 mm



SAE Open Stock - Reversing

PROD. NO.	Size	PROD. NO.	Size
701121	1/4"	701128	11/16"
701122	5/16"	701129	3/4"
701123	3/8"	701130	13/16"
701124	7/16"	701131	7/8"
701125	1/2"	701132	15/16"
701126	9/16"	701133	1"
701127	5/8"		

Metric Open Stock - Reversing

PROD. NO.	Size	PROD. NO.	Size
701173	8 mm	701179	14 mm
701174	9 mm	701180	15 mm
701175	10 mm	701181	16 mm
701176	11 mm	701182	17 mm
701177	12 mm	701183	18 mm
701178	13 mm	701184	19 mm

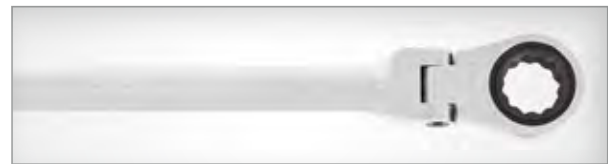

SAE Flex Head Open Stock - Non Reversing

PROD. NO.	Size	PROD. NO.	Size
701301	1/4"	701307	5/8"
701302	5/16"	701308	11/16"
701303	3/8"	701309	3/4"
701304	7/16"	701310	13/16"
701305	1/2"	701311	7/8"
701306	9/16"		

Metric Flex Head Open Stock - Non Reversing

PROD. NO.	Size	PROD. NO.	Size
701353	8 mm	701359	14 mm
701354	9 mm	701360	15 mm
701355	10 mm	701362	17 mm
701356	11 mm	701363	18 mm
701357	12 mm	701364	19 mm
701358	13 mm		

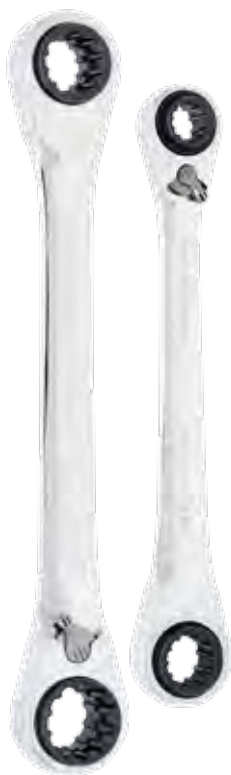

Adapter set converts ratcheting combination wrenches to socket or bit drivers

Socket adapters complete with quick release feature



RATCHETING WRENCHES

63-In-1 Multi-Fit Ratcheting Wrench Set

700392/MFRW-6300

- Multi-fit design fits SAE and Metric 6 point hex and 12 point double hex fasteners, as well as 4 point, Spline, and E-Torx fasteners
- 2 piece set fits 63 different sizes and types of fasteners providing unparalleled versatility
- 72 tooth ratcheting gear allows for just 5° swing arc for use in restricted spaces
- Premium quality SAE 6140 chrome vanadium steel for strength and durability
- Fully polished mirror finish with 3 layers of plating for superior corrosion resistance

NEW

JET
EXCLUSIVE

FITS:	6 & 12 pt SAE	6 & 12 pt Metric	4 pt SAE	4 pt Metric	Spline	E-Torx
	5/16	8	9/32	7	8	E10
	3/8	10	11/32	-	10	E12
	7/16	11	3/8	9	11	E14
	1/2	13	7/16	11	13	E16
	9/16	14	15/32	12	14	E18
	5/8	16	17/32	13	16	E20
	11/16	17	9/16	14	17	E22
	3/4	19	5/8	16	19	E24

Open Stock

PROD. NO.

700408	Fits 8-13 above	8 x 13 Multi-Fit Ratchet
700414	Fits 14-19 above	14 x 19 Multi-Fit Ratchet

4 PC Ratchet Wrench Adapter Set

701196 / RWAS-4S

- 1/4", 3/8", and 1/2" socket adapters and 1/4" hex bit adapter provide maximum versatility by turning your ratcheting wrench set into a full wrench, bit, and socket drive set
- Converts the wrench into an extremely low profile ratchet for access to the most limited spaces
- Works with flat, reversing, and flex head ratcheting combination wrenches
- Requires 3/8", 1/2", and 3/4" ratcheting wrenches (sold separately)
- Available in 4 pc set only

CONTENTS:

- **1/4" hex bit adapter** for use with 3/8" ratcheting wrench
- **1/4" drive socket adapter** for use with 3/8" ratcheting wrench
- **3/8" drive socket adapter** for use with 1/2" ratcheting wrench
- **1/2" drive socket adapter** for use with 3/4" ratcheting wrench
- Ratchet wrenches sold separately



FLARE NUT WRENCHES



- Flare nut wrenches are used on fasteners found on tubing ends or hoses, such as brake lines, hydraulic fittings, plumbing, etc
- Slot opening easily slides over tubing or hose to reach hex nuts at ends
- 6 point design allows for maximum contact on fastener for evenly distributed torque
- Reduces fastener damage

Flare Nut Wrench Sets

PROD. NO.	MOD. NO.	Type	Pieces (total)	Size	Holder
719001	FN-3	SAE	3	3/8" x 7/16" 1/2" x 9/16" 5/8" x 11/16"	Plastic Pouch
719006	FN-3M	Metric	3	10 x 11mm 12 x 13mm 15 x 17mm	Plastic Pouch



Flare Nut Wrenches - Open Stock

PROD. NO.	Type	Size
719002	SAE	3/8" x 7/16"
719003	SAE	1/2" x 9/16"
719004	SAE	5/8" x 11/16"
719007	Metric	10 x 11mm
719008	Metric	12 x 13mm
719009	Metric	15 x 17mm

CROWFOOT WRENCHES

- Sets include rail
- Used in restricted access spaces where a flare nut wrench cannot reach
- Slot opening easily slides over tubing or hose to reach hex nuts at ends
- Fully polished

PROD. NO.	MOD. NO.	Pieces	Drive	Size	Holder
719111	FNC-8	8	3/8"	3/8, 7/16, 1/2, 9/16, 5/8, 11/16, 3/4, 7/8"	Socket Rail
719121	FNC-10M	10	3/8"	10, 11, 12, 13, 14, 15, 16, 17, 18, 19mm	Socket Rail





ADJUSTABLE WRENCHES

Quick Snap Adjustable Wrench

- Patented adjustment plate and tooth system eliminates old fashioned knurl and is 5 times faster than traditional systems
- Pulling down on adjustment plate disengaged teeth and allows quick adjustment by simply pushing moving jaw until it meets fastener
- Dual frequency teeth guarantee exact fit on both SAE and Metric Fasteners
- Virtually no jaw play means no need to fine adjust wrench between fasteners
- Jaw remains parallel at all widths
- SAE and Metric scales for measuring fasteners
- 15° jaw angle provides greater leverage than standard 22° wrenches, reducing fatigue
- Heat treated chrome vanadium steel for professional use
- Dual material moulded grip for comfort and increased force

PROD. NO.	MOD. NO.	Length	Opening	Material
711191	JOSW-8	8"	1"	CrV

NEW

JET
EXCLUSIVE



Adjustable Wrench Set

- Professional quality
- Drop forged Chrome Vanadium steel
- Fully heat treated for strength and durability
- Accurately machined sliding jaw for smooth adjustment
- Traditional handle design

PROD. NO.	MOD. NO.	Length	Pieces	Opening	Material
711102	AW-3S	8", 10", 12"	3	1", 1-1/4", 1-1/2"	CrV

CrV



711102

Adjustable Wrenches - Open Stock

PROD. NO.	MOD. NO.	Length	Opening	Material
711111	AW-4	4" (100 mm)	1	CrV
711112	AW-6	6" (160 mm)	3/4"	CrV
711113	AW-8	8" (210 mm)	1"	CrV
711114	AW-10	10" (250 mm)	1-1/4"	CrV
711115	AW-12	12" (300 mm)	1-1/2"	CrV
711116	AW-15	15" (380 mm)	1-7/8"	Alloy
711117	AW-18	18" (450 mm)	2-1/8"	Alloy
711118	AW-24	24" (600 mm)	2-1/2"	Alloy

CrV



Professional Adjustable Wrenches - Super Heavy Duty

- Smaller 15° jaw angle provides greater leverage than standard 22° wrenches, reducing hand and arm fatigue
- Extra wide jaw openings fit an increased range of fasteners, offering greater versatility and value
- Thin tapered jaw reaches fasteners in narrow spaces with ease
- Jaw rack does not protrude past jaw when wrench is fully open, increasing clearance in tight access areas
- Thicker handle provides improved comfort and allows increased application of force
- SAE and Metric scales laser printed on jaws for convenient sizing of fasteners

PROD. NO.	MOD. NO.	Length	Opening	Material
711132	AWP-6	6" (160 mm)	7/8"	CrV
711133	AWP-8	8" (210 mm)	1"	CrV
711134	AWP-10	10" (250 mm)	1-3/16"	CrV
711135	AWP-12	12" (300 mm)	1-3/8"	CrV
711136	AWP-15	15" (380 mm)	1-15/16"	CrV
711137	AWP-18	18" (450 mm)	2-3/8"	CrV
711139	AWP-24	24" (600 mm)	2-1/2"	CrV



Industrial Adjustable Wrenches - Black Phosphate Finish - Super Heavy Duty

- Chrome Vanadium steel wrenches with black phosphate finish for use in applications where plated products are prohibited
- No chrome plate to peel or chip, causing contamination in sensitive applications
- Finish is non-reflective for military applications
- Black phosphate provides superior corrosion resistance versus black oxide finishes

PROD. NO.	MOD. NO.	Length	Opening	Material
711152	AWP-6B	6" (160 mm)	15/16"	CrV
711153	AWP-8B	8" (210 mm)	1-1/8"	CrV
711154	AWP-10B	10" (250 mm)	1-5/16"	CrV
711155	AWP-12B	12" (300 mm)	1-1/2"	CrV
711156	AWP-15B	15" (380 mm)	2"	CrV
711157	AWP-18B	18" (450 mm)	2-5/16"	CrV
711159	AWP-24B	24" (600 mm)	2-3/4"	CrV



711154

711157



715216

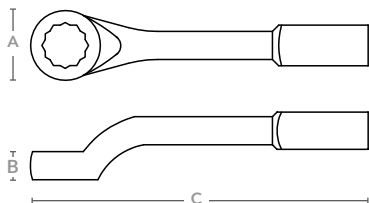

Special chamfering keeps wrench on fastener

STRIKING WRENCHES

SAE - Offset Style

- Drop forged Chrome Vanadium steel
- Heat treated for maximum strength
- Offset design allows clearance over work
- 12 point design for decreased swing room
- Special chamfering keeps wrench on fastener
- Protective coating minimizes corrosion
- Meets US Government standard GGG-W-636E and ANSI specifications
- 35 hex sizes from 1 - 3-1/8"

PROD. NO.	Size	Head Width (A)	Head Thickness (B)	Overall Length (C)
715201	1"	1-25/32"	25/32"	10-5/8"
715202	1-1/16"	1-25/32"	25/32"	10-5/8"
715203	1-1/8"	1-15/16"	7/8"	11"
715204	1-3/16"	1-15/16"	7/8"	11"
715205	1-1/4"	2-3/32"	29/32"	11-7/16"
715206	1-5/16"	2-3/32"	29/32"	11-7/16"
715207	1-3/8"	2-7/16"	31/32"	11-13/16"
715208	1-7/16"	2-7/16"	31/32"	11-13/16"
715209	1-1/2"	2-5/8"	1-1/32"	12-5/8"
715210	1-9/16"	2-5/8"	1-1/32"	12-5/8"
715211	1-5/8"	2-5/8"	1-1/32"	12-5/8"
715212	1-11/16"	2-5/8"	1-1/32"	12-5/8"
715213	1-3/4"	2-7/8"	1-1/16"	13-3/8"
715214	1-13/16"	2-7/8"	1/1/16"	13-3/8"
715215	1-7/8"	2-7/8"	1-1/16"	13-3/8"
715216	1-15/16"	3-1/16"	1-1/4"	13-3/4"
715217	2"	3-1/16"	1-1/4"	13-3/4"
715218	2-1/16"	3-5/16"	1-5/16"	4-3/16"
715219	2-1/8"	3-5/16"	1-5/16"	14-3/16"
715220	2-3/16"	3-5/16"	1-5/16"	14-3/16"
715221	2-1/4"	3-17/32"	1-3/8"	14-3/4"
715222	2-5/16"	3-17/32"	1-3/8"	14-3/4"
715223	2-3/8"	3-17/32"	1-3/8"	14-3/4"
715224	2-7/16"	3-17/32"	1-3/8"	14-3/4"
715225	2-1/2"	3-25/32"	1-1/2"	15-3/8"
715226	2-9/16"	3-25/32"	1-1/2"	15-3/8"
715227	2-5/8"	3-25/32"	1-1/2"	15-3/8"
715228	2-11/16"	4-1/8"	1-5/8"	15-3/4"
715229	2-3/4"	4-1/8"	1-5/8"	15-3/4"
715230	2-13/16"	4-1/8"	1-5/8"	15-3/4"
715231	2-7/8"	4-11/32"	1-11/16"	16-9/16"
715232	2-15/16"	4-11/32"	1-11/16"	16-9/16"
715233	3"	4-11/32"	1-11/16"	16-9/16"
715234	3-1/16"	4-21/32"	1-25/32"	17-5/16"
715235	3-1/8"	4-21/32"	1-25/32"	17-5/16"

12 CrV

SAE - Offset Style

- Drop forged Chrome Vanadium steel
- Heat treated for maximum strength
- Offset design allows clearance over work
- Round tapered stock allows use as aligning bar
- Protective coating minimizes corrosion
- Meets US government standard GGG-W-636E

PROD. NO.	Size	Head Width (A)	Head Thickness (B)	Overall Length (C)
719151	3/4"	1-3/4"	13/32"	13-1/8"
719153	7/8"	2-9/32"	7/16"	13-3/4"
719154	15/16"	2-9/32"	7/16"	14-5/8"
719155	1"	2-9/32"	7/16"	14-5/8"
719156	1-1/16"	2-9/32"	7/16"	14-5/8"
719157	1-1/8"	2-1/2"	19/32"	14-5/8"
719159	1-1/4"	2-1/2"	19/32"	15-3/4"
719162	1-7/16"	3-1/16"	23/32"	16-7/8"
719163	1-1/2"	3-1/16"	23/32"	18-1/2"
719165	1-5/8"	3-5/8"	23/32"	18-1/2"

CrV

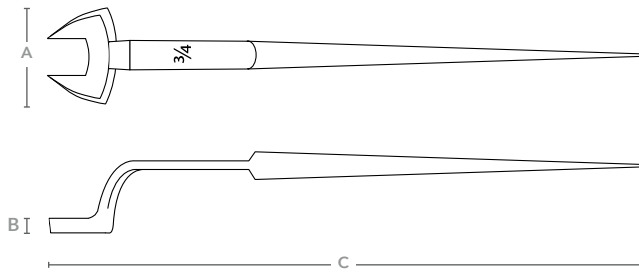

15" Adjustable Construction Wrench

- Drop forged heat treated steel for professional use
- Adjustable up to 1-5/8" for maximum convenience
- Eliminates the need to carry multiple wrenches
- Tapered shaft aids in aligning bolt holes
- Continuous taper reduces binding
- Precisely ground jaws remain parallel at all opening widths for better grip
- Ultra smooth acting knurl for fast adjustment
- Flat neck allows use of lanyard for added safety

PROD. NO.	MOD. NO.	Head Width (A)	Head Thickness (B)	Overall Length (C)
711146	AWC-15	3-1/2"	5/8"	15-3/4"



719151



ADJUSTABLE SPANNER WRENCHES

- Black oxide finish resists corrosion
- Adjustable wrenches fit a wide variety of sizes
- Slotted or pin style wrenches
- For use on collars, locknut rings and bearings



710904



710914

Hook Style

PROD. NO.	MOD. NO.	Length	Capacity	Type
710902	JHSW-102	6-1/2"	3/4 - 2"	Hook
710903	JHSW-103	8"	1-1/4 - 3"	Hook
710904	JHSW-104	11-1/2"	2 - 4-3/4"	Hook

Pin Style

PROD. NO.	MOD. NO.	Length	Capacity	Pin Size	Type
710912	JPSW-102	6-1/2"	3/4 - 2"	1/8"	Pin
710913	JPSW-103	8"	1-1/4 - 3"	3/16"	Pin
710914	JPSW-104	11-1/2"	2 - 4-3/4"	1/4"	Pin



HEX KEY WRENCHES





775144



775146



775153



775156



775192



775112



775114



775191

HEX KEY WRENCHES - SETS

Folding Hex and TORX® Key Sets

- Fully hardened steel case with ergonomic bi-material grip for added comfort and sure grip
- Steel reinforced on inside for maximum strength
- Heat treated Chrome Vanadium steel keys
- Unique offset washers between keys applies tension, holding keys firmly in place while in use

PROD. NO.	MOD. NO.	Pieces	Sizes
775144	JFHK-9	9	5/64, 3/32, 7/64, 1/8, 9/64, 5/32, 3/16, 7/32, 1/4"
775146	JFHK-7L	7	1/8, 5/32, 3/16, 7/32, 1/4, 5/16, 3/8"
775153	JFHK-7M	7	1.5, 2, 2.5, 3, 4, 5, 6 mm
775156	JFHK-7ML	7	3, 4, 5, 5.5, 6, 8, 10 mm
775192	JFTK-8	8	T8, T10, T15, T20, T25, T27, T30, T40



Short Arm Hex and TORX® Key Sets

- Precision chamfering for ease of insertion
- Industrial heat treated Chrome Vanadium steel
- Convenient carrying case keeps hex keys organized

PROD. NO.	MOD. NO.	Pieces	Sizes
775112	JHK-13	13	0.05, 1/16, 5/64, 3/32, 7/64, 1/8, 9/64, 5/32, 3/16, 7/32, 1/4, 5/16, 3/8"
775114	JHK-9M	9	1.5, 2.0, 2.5, 3.0, 4.0, 5.0, 6.0, 8.0, 10 mm
775191	JTK-9TP	9	T10, T15, T20, T25, T27, T30, T40, T45, T50



TORX® is a registered trademark of Acument Intellectual Properties, LLC.

Long Arm Ball Nose Sets

- Long arm series allows access into tough spots and more torque on the fastener
- Ball nose design allows engagement of fastener at up to 25° angle
- Precision chamfering for ease of insertion
- Industrial heat treated Chrome Vanadium steel
- Convenient carrying case keeps hex keys organized
- 22 PC sets combine 13 PC SAE and 9 PC Metric with a convenient centre post that converts to a comfortable T or L-Handle
- All items meet ANSI standards for hardness and torque



Centre post converts to a T or L-handle



775164

PROD. NO.	MOD. NO.	Pieces	Sizes
775164	JBHK-22SM	22	0.05, 1/16, 5/64, 3/32, 7/64, 1/8, 9/64, 5/32, 3/16, 7/32, 1/4, 5/16, 3/8", 1.5, 2.0, 2.5, 3.0, 4.0, 5.0, 6.0, 8.0, 10.0 mm
775173	JBHK-10	10	1/16, 5/64, 3/32, 1/8, 5/32, 3/16, 7/32, 1/4, 5/16, 3/8"
775184	JBHK-9M	9	1.5, 2.0, 2.5, 3.0, 4.0, 5.0, 6.0, 8.0, 10.0 mm



Long Arm Flat Nose Set

- Same quality features as 775164, except with flat nose at both ends of the hex key

PROD. NO.	MOD. NO.	Pieces	Sizes
775162	JHK-22SM	22	0.05, 1/16, 5/64, 3/32, 7/64, 1/8, 9/64, 5/32, 3/16, 7/32, 1/4, 5/16, 3/8", 1.5, 2.0, 2.5, 3.0, 4.0, 5.0, 6.0, 8.0, 10.0 mm



775173

775184



775162



775175

775185



775186



HEX KEY WRENCHES - SETS

Extra Long Ball Nose Sets

- Extra long - up to 30% longer than conventional hex long arm keys. Improves reach and provides more torque
- Hex end for extra torque - use for initial loosening and final tightening
- Ball nose allows angle entry - perfect for blind applications
- Super bright finish for excellent rust resistance
- S2 alloy steel hardened to HRC58-62 allows 50% more torque than CrV keys
- Improved folding case for easier access to smaller sizes
- Exceeds ANSI standards for hardness and torque

PROD. NO.	MOD. NO.	Pieces	Sizes
775175	JBHK-9XL	9	1/16, 5/64, 3/32, 1/8, 5/32, 3/16, 1/4, 5/16, 3/8"
775185	JBHK-9XLM	9	1.5, 2.0, 2.5, 3.0, 4.0, 5.0, 6.0, 8.0, 10.0 mm



Jumbo Extra Long Ball Nose Sets

- Same great features our Extra Long Ball Nose series except with larger sizes for all heavy duty applications
- Complete with handy organizer

PROD. NO.	MOD. NO.	Pieces	Sizes
775176	JBHK-17XL	17	0.05, 1/16, 5/64, 3/32, 7/64, 1/8, 9/64, 5/32, 3/16, 7/32, 1/4, 5/16, 3/8, 1/2, 9/16, 5/8, 3/4"
775186	JBHK-17LM	17	1.3, 1.5, 2.0, 2.5, 3.0, 3.5, 4.0, 5.0, 5.5, 6.0, 7.0, 8.0, 10, 12, 14, 17, 19 mm



T-Handle Hex Key / Torx® Key Sets

- PVC grip provides comfort and allows increased torque
- S2 alloy steel hardened to HRC58-62 for maximum strength and endurance
- Flat nose design for highest torque on the torque on the toughest fasteners
- Colour coded to indicate SAE, Metric, or Torx® sizes
- Manganese phosphate finish resists corrosion

PROD. NO.	MOD. NO.	Description	Sizes
775109	JTHK-10	10 PC SAE T Handle Hex Key Set	3/32, 7/64, 1/8, 9/64, 5/32, 3/16, 7/32, 1/4, 5/16, 3/8"
775105	JTHK-8M	8 PC Metric T Handle Hex Key Set	2.0, 2.5, 3.0, 4.0, 5.0, 6.0, 8.0, 10.0 mm
775103	JTTK-7	7 PC T Handle Torx Key Set	T10, T15, T20, T25, T30, T40, T45

NEW

L-Handle Style Hex and TORX® Key Sets

- Hard composite material combined with soft rubber form a unique ergonomic handle for optimal grip and unsurpassed comfort
- Handles are moulded around keys ensuring maximum strength and preventing keys and handles from separating
- S2 alloy steel hardened to HRC58-62 allows 50% more torque than CrV keys
- Super long keys for maximum reach - our longest hex keys
- Ball nose allows angle entry - perfect for blind applications (Hex Key Only)
- Short end for extra torque - use for initial loosening and final tightening
- TORX® keys are regular style on one end and tamperproof on the other
- Super bright finish for excellent rust resistance
- Exceeds ANSI standards for hardness and torque
- Comes with blow mould case

PROD. NO.	MOD. NO.	Pieces	Sizes
775104	JTHK-9	9	5/64, 3/32, 1/8, 5/32, 3/16, 7/32 1/4, 5/16, 3/8"
775106	JTHK-9M	9	2.0, 2.5, 3.0, 4.0, 5.0, 5.5, 6.0, 8.0, 10.0 mm
775108	JTTK-9	9	T10, T15, T20, T25, T27, T30, T40, T45, T50



Short/Long Arm Combination SAE/Metric Set

- Keys made of heat treated Chrome Vanadium steel
- Quality set at an economical price
- SAE keys are long arm, Metric keys are short arm
- Complete with blow mould carrying case

PROD. NO.	MOD. NO.	Pieces	Sizes
775165	JHK-25SM	25	Long Arm 1/16, 5/64, 3/32, 7/64, 1/8, 9/64, 5/32, 3/16, 7/32, 1/4, 5/16, 3/8"
			Short Arm 1.5, 2.0, 2.5, 3.0, 4.0, 4.5, 5.0, 5.5, 6.0, 7.0, 8.0, 9.0, 10.0 mm



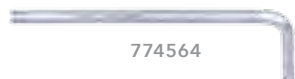
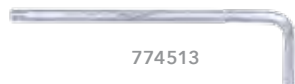

HEX KEY WRENCHES

Hextractor™ Hex Key - Sets

- Patented design bites into rounded fasteners, making removal fast and easy
- Hextractor teeth on both ends of key provide extra torque or increased reach
- Works on left and right hand threaded fasteners
- Safe for use on undamaged fasteners
- Heat treated S2 steel allows up to 50% more torque than CrV hex Keys
- Patented case can be used as a T handle while still keeping keys organized
- Case includes belt clip and hanger for convenient storage

PROD. NO.	MOD. NO.	Pieces	Sizes
775122	JHHK-8	8	5/64, 3/32, 1/8, 5/32, 3/16, 1/4, 5/16, 3/8"
775127	JHHK-8M	8	2, 2.5, 3, 4, 5, 6, 8, 10 mm

NEW

JET
EXCLUSIVE

S2

HEXTRACTOR™ HEX KEY - OPEN STOCK

PROD. NO.	Description
774507	5/64"
774508	3/32
774510	1/8
774512	5/32
774513	3/16"
774515	1/4"
774517	5/16"
774519	3/8"
774557	2 mm
774558	2.5 mm
774559	3 mm
774560	4 mm
774562	5 mm
774564	6 mm
774566	8 mm
774568	10 mm

HEX KEY WRENCHES - OPEN STOCK



Set #	775165	775164 775173	775175 775176	775104	775109
SAE	Long Arm	CrV Long Ball Nose	S2 Extra Long Ball Nose	S2 L-Handle	T-Handle
0.05"		774905	775005		
1/16"	774806	774906	775006		
5/64"	774807	774907	775007	774607	
3/32"	774808	774908	775008	774608	774408
7/64"	774809	774909	775009		774409
1/8"	774810	774910	775010	774610	774410
9/64"	774811	774911	775011		774411
5/32"	774812	774912	775012	774612	774412
3/16"	774813	774913	775013	774613	774413
7/32"	774814	774914	775014	774614	774414
1/4"	774815	774915	775015	774615	774415
5/16"	774817	774917	775017	774617	774417
3/8"	774819	774919	775019	774619	774419
1/2"			775021		
9/16"			775022		
5/8"			775023		
3/4"			775025		

NEW



774619



774699



774668



774668

HEX KEY WRENCHES - OPEN STOCK

Set #	775165	775164 775184	775185 775186	775106	775105
Metric	Short Arm	CrV Long Ball Nose	S2 Extra Long Ball Nose	S2 L-Handle	T-Handle
1.3 mm			775054		
1.5 mm	774756	774956	775056		
2.0 mm	774757	774957	775057	774657	774457
2.5 mm	774758	774958	775058	774658	774458
3.0 mm	774759	774959	775059	774659	774459
3.5 mm			775060		
4.0 mm	774760	774960	775061	774660	774460
4.5 mm	774761				
5.0 mm	774762	774962	775063	774662	774462
5.5 mm	774763		775064	774663	
6.0 mm	774764	774964	775065	774664	774464
7.0 mm	774765		775067		
8.0 mm	774766	774966	775069	774666	774466
9.0 mm	774767				
10.0 mm	774768	774968	775073	774668	774468
12.0 mm			775075		
14.0 mm			775077		
17.0 mm			775080		
19.0 mm			775082		

NEW

TORX® KEY WRENCHES - OPEN STOCK

Set #	775108	775103
TORX®	S2 L-Handle	T-Handle
T10	774691	774491
T15	774692	774492
T20	774693	774493
T25	774694	774494
T27	774695	
T30	774696	774496
T40	774697	774497
T45	774698	774498
T50	774699	



TORQUE WRENCHES





718912



719069

Bubble magnifier analogue scale

TORQUE WRENCHES

JTW Series

- 24 tooth Chrome Vanadium ratchet gear (Chrome Molybdenum on 3/4" model)
- Reversible ratchet
- Dual ft/lb and Nm scales
- Patented lock ring
- Comfortable ergonomic handle grip
- Complete with protective blow mould case
- Perceptible jolt and audible click to indicate desired setting has been reached
- All models are factory calibrated to +/-4% with certificate and meet ISO 6789 - 1992, ANSI specifications, BSEN 26789-1994 and U.S. Government Federal Specifications GGG-W-00686C

PROD. NO.	MOD. NO.	Drive	Torque Range	Length
718902	JTW-1425	1/4"	40-250 in/lb (6-30Nm)	13-3/4"
718908	JTW-3880	3/8"	15-80 ft/lb (19-110Nm)	15-1/4"
718911	JTW-12150	1/2"	30-150 ft/lb (40-210Nm)	21"
718912	JTW-12250	1/2"	50-250 ft/lb (70-350Nm)	25-1/2"
718918	JTW-34600	3/4"	100-600 ft/lb (140-700Nm)	43"
718922	JTW-10700	1"	135-700 ft/lb (135-949Nm)	48"

CrV

JMTW Slim Head Series - Heavy Duty

- Easy to use micrometer adjustment with locking nut or button
- Reversible ratchet
- Perceptible jolt and audible click to indicate desired setting has been reached
- Clearly visible analogue scale with exclusive bubble magnifier
- Patented lock button in the handle
- May be used on left and right hand threads simply by pushing the drive plug through the wrench
- Built tough for demanding professionals
- Factory calibrated to +/-4%
- Meets US Government Federal specification GGG-W-00686C

PROD. NO.	MOD. NO.	Drive	Torque Range	Length
718906	JMTW-3800	3/8"	10-80 ft/lb (10-100 Nm)	16"
719069	JMTW-5250	1/2"	30-250 ft/lb (30-340Nm)	24"

JET offers certified recalibration service on torque wrenches

JPTW Series - Heavy Duty

- Measures torque in both directions with just a flip of the direction lever - no need to push anvil through wrench
- Reversible ratchet
- 32 tooth configuration requires just 11.5° swing room
- Pull-down locking ring above handle grip securely holds set torque value
- Quick release ratchet holds sockets on until released
- Permanently etched scale will not fade or wear off
- Rubber over-moulded handle for safe, secure grip
- Reinforced pawl blocks for maximum strength
- Accurate to 4% CW, 6% CCW
- All models are factory calibrated with certificate and meet ISO 6789 - 1992, ANSI specifications, BSEN 26789-1994 and U.S. Government Federal Specifications GGG-W-00686C

PROD. NO.	MOD. NO.	Drive	Torque Range	Length
718933	JPTW-38100	3/8"	20 - 100 ft/lb	18-1/2"
718936	JPTW-12250	1/2"	50 - 250 ft/lb	22"



Convenient pull-down locking ring

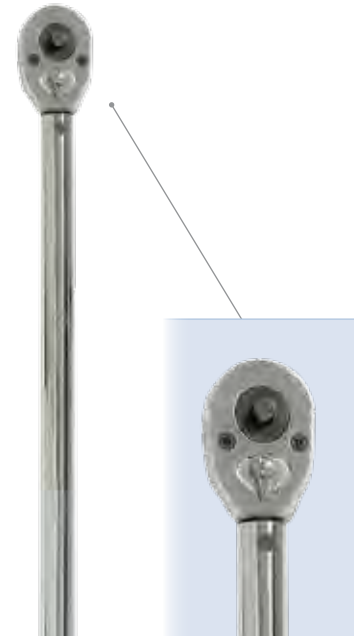

Quick release head

718936

JET offers certified recalibration service on torque wrenches



Quick release head



TORQUE WRENCHES

JSHD Series - Super Heavy Duty

- Magnified view window shows torque value in numbers only - no scale lines to read!
- Highest quality Japanese spring resists fatigue for long service life
- Patented dual roller reaction bar system minimizes friction for increased accuracy
- Hardened steel tube will not deflect under strain and will not be scratched by internal parts, ensuring reduced friction and highest possible accuracy
- Conversion scale permanently etched into tube for easy conversion to Nm
- Patented positive lock prevents accidental adjustment of torque value
- Quick release ratchet holds sockets on until released
- Sure grip handle with finger groove ensures correct placement of hand for better accuracy
- 48 tooth quick release reversible ratchet head - our best!
- Drop forged Chrome Molybdenum ratchet pawls for maximum strength
- Lifetime tested to a minimum of 3 x ISO standards

PROD. NO.	MOD. NO.	Drive	Torque Range	Length
718952	JSHD-14250	1/4"	50 - 250 in/lb	12-3/4"
718956	JSHD-3875	3/8"	15 - 75 ft/lb	15-3/4"
718961	JSHD-12150	1/2"	30 - 150 ft/lb	20-3/8"
718962	JSHD-12250	1/2"	50 - 250 ft/lb	24-1/2"



Torque Screwdriver

- 1/4" drive screwdriver can be used with 1/4" hex bits or 1/4" drive sockets
- 10 - 50 in/lb torque range
- Complete with assortment of 20 popular bits
- Comes in handy blow mould case

PROD. NO.	MOD. NO.	Drive	Torque Range	Length
718991	JTSD-1450K	1/4"	10-50 in/lb	6"



JET offers certified recalibration service on torque wrenches



Digital Torque Wrenches

- Digital readout signals torque audibly and visually
- 12 multi coloured lights with beeper signal torque even when display cannot be read
- Measures torque in both directions
- Accurate to +/-2% CW, +/-3% CCW from 20% - 100% of scale
- Quickly converts between in/lb, ft/lb, cm/kg, and Nm scales
- Stores up to 9 torque values for quick access to commonly used settings
- Display tracks torque as it is applied or can be set to display peak torque
- Records up to 50 Peak Hold values for accurate record keeping
- Large handle features soft touch TPR grip for user comfort
- Industrial quality 36 tooth sealed ratchet head
- Simple intuitive menu
- Meets ISO 6789-1992 and ANSI standards
- Blow mould case

PROD. NO.	MOD. NO.	Drive	Torque Range	Length
718941	JDTW-14250	1/4"	13.3 - 265.5 in/lb 1.5 - 30Nm	15-11/32"
718943	JDTW-38100	3/8"	5 - 99.5 ft/lb 6.8 - 135Nm	16-5/16"
718946	JDTW-12250	1/2"	12.5 - 250.5 ft/lb 17 - 340Nm	25-1/2"



LED lights signal torque

Simple intuitive menu

718946

JET offers certified recalibration service on torque wrenches



TORQUE MULTIPLIERS - HEAVY DUTY



Reaction base and 90° reaction bar

- Used to multiply applied force for setting and removing high torque fasteners
- Planetary gear system multiples input force many times
- Torque multipliers lower physical effort, resulting in smooth, steady application of torque and increased accuracy
- Permits application of high torque without use of a long lever
- Can be driven with a torque wrench
- Kit includes straight and 90° reaction bars with reaction base (base not included in 719071 kit)
- 90° bar and base rests against truck wheel rims when used to torque lug nuts
- 1/2" drive models available with 3.3:1, 6.5:1 and 12:1 torque ratios
- Higher ratios require lower input forces, reducing operator effort
- All models include breakaway input adapter to protect wrench from overload

JTM Series Kits

PROD. NO.	MOD. NO.	Input Drive	Output Drive	Gear Ratio	Torque Ratio	Max. Input	Max. Output
719071	JTM-50750	1/2"	3/4"	4:1	3.3:1	227 ft/lb	750 ft/lb
719072	JTM-51100	1/2"	3/4"	9:1	6.5:1	170 ft/lb	1,100 ft/lb
719074	JTM-51850	1/2"	1"	16:1	12:01	154 ft/lb	1,850 ft/lb
719075	JTM-71850	3/4"	1"	4:1	3.3:1	560 ft/lb	1,850 ft/lb



719071



719075



WARNING: Do not use impact tools with torque multipliers. Serious damage or injury could occur.



SCREWDRIVERS BITS NUT DRIVERS





720505



720956



720574



720507



WARNING: Insulated handles rated for use to 220V only. Do not use on higher voltage circuits. Not for use on live circuits

JUMBO HANDLE SERIES – SETS

- Jumbo grip grooved handle design ensures maximum torque for tough jobs
- Made with super acetates these handles are virtually indestructible
- Shafts made of the highest quality Chrome Vanadium steel for long life and maximum durability
- Black hardened magnetic tips eliminate chrome plating chipping off the tip (common on other brands); holds the screw to the screwdriver and ensures maximum durability and life
- All items meet ANS Specifications, U.S. Specifications GGG-S-121E and Canadian Government specifications CDA39-GP-17C

6 PC Basic Set

720505 / JHSS-6

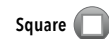

1/4 x 4"
5/16 x 6"

#1 x 3"
#2 x 4"

#1 x 4"
#2 x 5"

- Handy storage rack



6 PC Torx Set

720956 / JHTSS-6



T10 x 4", T15 x 4", T20 x 4", T25 x 4", T27 x 4", T30 x 4"

- Terylene Pouch



13 PC Mechanic's Set

720574 / JHMSS-13



1/4 x 1-1/2"
1/4 x 4"
5/16 x 6"
3/8 x 10"

#1 x 3"
#2 x 1-1/2"
#2 x 4"

T10 x 4"
T15 x 4"
T20 x 4"
T25 x 4"
T27 x 4"
T30 x 4"

- Supplied in convenient blow mould tray



14 PC Master Set

720507 / JHSS-14



#2 x 1-1/2"
#1 x 3"
#2 x 4"
#3 x 6"

#2 x 1-1/2"
#1 x 4"
#2 x 5"
#3 x 6"

1/4 x 1-1/2"
1/4 x 4"
5/16 x 6"
3/8 x 10"

3/16 x 3"
3/16 x 6"

- Supplied in convenient blow mould tray



Slot – Square Shank

PROD. NO.	MOD. NO.	Size
720354	SDS-4S	1/4 x 4"
720356	SDS-6S	5/16 x 6"
720360	SDS-10S	3/8 x 10"
720362	SDS-12S	3/8 x 12"
720392	SDS-2SS	1/4 x 1-1/2" (Stubby)



Slot – Round Shank

PROD. NO.	MOD. NO.	Size
720363	SDS-3R	3/16 x 3"
720366	SDS-6R	3/16 x 6"



Phillips – Round Shank

PROD. NO.	MOD. NO.	Size
720371	SDP-1	#1 x 3"
720372	SDP-2	#2 x 4"
720373	SDP-3	#3 x 6"
720382	SDP-2S	#2 x 1-1/2" (Stubby)



Square – Round Shank

PROD. NO.	MOD. NO.	Size
721361	SDR-1	#1 x 4"
721362	SDR-2	#2 x 5"
721363	SDR-3	#3 x 6"
721372	SDR-2S	#2 x 1-1/2" (Stubby)



TORX® – Round Shank

PROD. NO.	MOD. NO.	Size
720911	SDT-10	T10 x 4"
720917	SDT-15	T15 x 4"
720922	SDT-20	T20 x 4"
720925	SDT-25	T25 x 4"
720929	SDT-27	T27 x 4"
720932	SDT-30	T30 x 4"





TORQUE DRIVE®



720508

TORQUE DRIVE® SERIES – SETS

- JET's Exclusive TORQUE DRIVE® cushion grip ergonomic handle design guarantees maximum torque and unparalleled user comfort increasing performance and productivity
- Black hardened magnetic tips eliminate chrome plating chipping off the tip (common on other brands); holds the screw to the screwdriver and ensures maximum durability and life
- Shafts made of the highest quality Chrome Vanadium steel for long life and maximum durability
- "Go thru" design offers a one piece Chrome Vanadium steel for long life and maximum durability
- All items meet U.S. Specifications GGG-S-121E and Canadian Government specifications CDA39-GP-17C

6 PC Basic Set

720508 / TDSS-6

Slot

Phillips

Square

1/4 x 4"
5/16 x 6"#1 x 4"
#2 x 4"#1 x 4"
#2 x 4"

CrV

- JET's Exclusive TORQUE DRIVE® cushion grip ergonomic handle design guarantees maximum torque and unparalleled user comfort increasing performance and productivity
- Black hardened magnetic tips eliminate chrome plating chipping off the tip, holds the screw to the screwdriver and ensures maximum durability and life
- Shafts made of the highest quality Chrome Vanadium steel for long life and maximum durability
- "Go thru" design offers a one piece metal shaft from handle to tip
- All items meet U.S. Specifications GGG-S-121E and Canadian Government specifications CDA39-GP-17C

TORQUE DRIVE®



Slot – Round Shank

PROD. NO.	MOD. NO.	Size
720404	TDS-4	1/4 X 4"
720406	TDS-6	5/16 x 6"
720444	TDS-4N	3/16 x 4"
720446	TDS-6N	3/16 x 6"



CrV

Phillips – Round Shank

PROD. NO.	MOD. NO.	Size
720421	TDS-1P	#1 x 4"
720422	TDS-2P	#2 x 4"
720423	TDS-3P	#3 x 6"



CrV

Square – Round Shank

PROD. NO.	MOD. NO.	Size
720431	TDS-1R	#1 x 4"
720432	TDS-2R	#2 x 4"
720433	TDS-3R	#3 x 6"



CrV



ERGONOMIC SCREWDRIVERS – SETS

- Unique handle design conforms to the hand for exceptional comfort and grip
- Co-moulded Polypropylene (PP) and Thermoplastic Vulcanizates (TPV) ensure maximum strength balanced with superior non-slip grip
- Resistant to most chemicals, solvents, and oil
- Pentagon shaped neck bolster minimizes roll away
- Tip size and style on handle end for easy identification in tool pouch
- Patented SVCM tool steel is up to 30% stronger than CrV screwdrivers
- Phosphate plated tip will not chip or peel
- Meets ANSI specifications



720523



720524



720527

9 PC Ergonomic Screwdriver Set

720523 / JSTD-9S

Slot

Phillips

Square

3/16 x 3"
1/4 x 4"
5/16 x 6"

#1 x 3"
#2 x 4"
#3 x 6"

#1 x 4"
#2 x 4"
#3 x 4"

SVCM

14 PC Ergonomic Screwdriver Set

720524 / JSTD-14S

Slot

Phillips

Square

3/16 x 3"
3/16 x 6"
1/4 x 1-1/2"
1/4 x 4"
5/16 x 6"
3/8 x 8"

#1 x 3"
#2 x 1-1/2"
#2 x 4"
#3 x 6"

#1 x 4"
#2 x 1-1/2"
#2 x 4"
#3 x 4"

SVCM

7 PC Ergonomic TORX® Driver Set

720527 / JSTD-7TS

TORX®

T10 x 4", T15 x 4", T20 x 4", T25 x 4", T27 x 4", T30 x 4", T40 x 4"

SVCM

Cabinet Tip Slot

PROD. NO.	MOD. NO.	Size
720812	JTCS-3	3/16 x 3"
720813	JTCS-6	3/16 x 6"



SVCM

Keystone Tip Slot

720814	JTSS-2	1/4 x 1-1/2"
720815	JTSS-4	1/4 x 4"
720817	JTSS-6	5/16 x 6"
720818	JTSS-8	3/8 x 8"



SVCM

Phillips

720821	JTPH-1	#1 x 3"
720823	JTPH-2S	#2 x 1-1/2"
720824	JTPH-2	#2 x 4"
720827	JTPH-3	#3 x 6"



SVCM

Square

720832	JTSR-1	#1 x 4"
720834	JTSR-2S	#2 x 1-1/2"
720835	JTSR-2	#2 x 4"
720837	JTSR-3	#3 x 4"



SVCM

TORX®

720841	JTST-10	T10 x 4"
720842	JTST-15	T15 x 4"
720843	JTST-20	T20 x 4"
720844	JTST-25	T25 x 4"
720845	JTST-27	T27 x 4"
720846	JTST-30	T30 x 4"
720848	JTST-40	T40 x 4"



SVCM



720844



720812



720823



720835





CUSHION GRIP SCREWDRIVERS – SETS

- Patented SVCM tool steel is up to 30% stronger than CrV screwdrivers
- Hardened and tempered for superior strength and improved durability
- Super strong acetate handles resist impact and chemicals
- Integrated cushion grips provide all day comfort and increased torque
- Chrome plated for superior corrosion resistance
- Precision machined phosphate plated tips for superior fit in all screw head types
- Tip type permanently engraved on handle ends for easy identification in tool pouch



720560

4 PC Cushion Grip Mini Screwdriver Set

720560 / JKS-4SM

Slot - Round Shank

Phillips

1/16" x 3"
3/32" x 3"
1/8" x 3"

#0 x 3"

SVCM



720562

4 PC Extra Long Cushion Grip Screwdriver Set

720562 / JKS-4SL

Slot - Round Shank

Phillips

Square

3/8" x 10"
3/8" x 12"

#2 x 10"

#2 x 8"

SVCM



720564

9 PC Cushion Grip Screwdriver Set

720564 / JKS-9S

Slot - Square Shank

Phillips

Square

3/16" x 3"
1/4" x 4"
5/16" x 6"

#1 x 3"
#2 x 4"
#3 x 6"

#1 x 4"
#2 x 4"
#3 x 4"

SVCM



720566

14 PC Cushion Grip Screwdriver Set

720566 / JKS-14S

Slot - Square Shank

Slot Stubby Round Shank

Cabinet Tip

Phillips

Square

1/4" x 4"
5/16" x 6"
3/8" x 8"

1/4" x 1-1/2"

3/16" x 3"
3/16" x 6"

#1 x 3"
#2 x 1-1/2"
#2 x 4"
#3 x 6"

#1 x 4"
#2 x 1-1/2"
#2 x 4"
#3 x 4"

SVCM

Miniature – Slot/Phillips – Round Shank

PROD. NO.	MOD. NO.	Size
720605	JKMS-116	1/16" x 3"
720606	JKMS-332	3/32" x 3"
720607	JKMS-18	1/8" x 3"
720641	JKMP-0	PH#0 x 3"



SVCM

Slot – Square Shank

720612	JKSS-4	1/4" x 4"
720613	JKSS-6	5/16" x 6"
720616	JKSS-8	3/8" x 8"



SVCM

Slot – Round Shank

720621	JKSS-2RS	1/4" x 1-1/2"
720622	JKSS-4R	1/4" x 4"
720623	JKSS-6R	5/16" x 6"
720626	JKSS-8R	3/8" x 8"
720627	JKSS-10R	3/8" x 10"
720628	JKSS-12R	3/8" x 12"



SVCM

Cabinet Tip – Round Shank

720632	JKSS-3CT	3/16" x 3"
720633	JKSS-4CT	3/16" x 4"
720634	JKSS-6CT	3/16" x 6"
720635	JKSS-8CT	3/16" x 8"



SVCM

Phillips – Round Shank

720642	JKSP-1	PH1 x 3"
720644	JKSP-2S	PH2 x 1-1/2"
720646	JKSP-2	PH2 x 4"
720648	JKSP-2L	PH2 x 10"
720649	JKSP-3	PH3 x 6"



SVCM

Square – Round Shank

720653	JKSR-1	R1 x 4"
720654	JKSR-2S	R2 x 1-1/2"
720656	JKSR-2	R2 x 4"
720658	JKSR-2L	R2 x 8"
720659	JKSR-3	R3 x 4"



SVCM



Replacement Bits - See page 343



Distributors please note: Drivers are sold in 6 pack POP display only.

CUSHION GRIP MULTI-BIT DRIVERS - SETS

- Super strong acetate handle resists impact and chemicals
- Integrated cushion grip provides all day comfort and increased torque
- Chrome plated for superior corrosion resistance
- Double ended bits for maximum versatility with minimal pieces
- Can be used as a nut driver with bits removed

5-in-1 Cushion Grip Multi-Bit Screwdriver

720531 / JKMD-5S

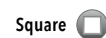

3/16 & 1/4"

#2

#2

1/4"

6-in-1 Cushion Grip Multi-Bit Screwdriver

720533 / JKMD-6

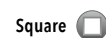

3/16 & 1/4"

#2

#2

1/4" & 5/16"

10-in-1 Cushion Grip Multi-Bit Screwdriver

720534 / JKMD-10

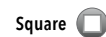

3/16 & 1/4"

#1, #2, #3

#1, #2, #3

1/4" & 5/16"

MULTI-BIT DRIVERS

15-In-1 Multi-Bit Screwdriver

H3400

- Features a patented pullout bit cartridge
- 15-in-1 multi-bit screwdriver replaces 14 of the most popular bits and 14 screwdrivers and a 1/4" hex nut drive
- 2" double end bits are made of superior quality S2 steel for strength and durability
- Shaft is made of super high strength 12T14 steel for long life
- End of shaft is a 1/4" hex nut drive
- Handle is made of durable nylon reinforced Triax® resin for longest life
- Unique rotating cap design allows you to position the cap in the palm of your hand and rotate the driver handle with your fingers. The driver then acts like a gearless ratcheting screwdriver increasing productivity while reducing blisters and operator fatigue
- Drivers are easy to use from both the left and right sides allowing you to use them in tight confined areas
- Collar also swivels 360° for fast efficient driving of screws
- Made in the U.S.A.





19-in-1 Multi-Bit Screwdriver

720590 / JRSD-19

- 19-in-1 screwdriver features 8 double ended bits and 3 nut driver sizes
- Heavy duty reversible 25 tooth ratchet with centre lock position
- Ergonomic handle for comfort and secure grip
- Bits store in handle
- Available in 12 piece POP display



8 1/4" Double-Ended Bits

	&			&S	
	&			&T	
	&			&T	
	&			&3	



Replacement Bits - See page 343



720590

Distributors please note: Drivers are sold in 12 pack POP display only.



RATCHETING DRIVERS

- 45 tooth all steel ratchet mechanism provides high torque and smooth operation
- Lifetime tested to 50,000 cycles
- Soft textured handle provides excellent grip
- Chrome Vanadium steel shaft with powerful bit holder magnet

Convertible Pistol Grip Ratcheting Screwdriver

720551 / JPRSD-9

- Spring loaded cartridge in handle pops out with a simple squeeze of the recessed buttons and holds 6 bits on board
- Complete with 6 nickel plated S2 bits and 1/4" socket drive adapter
- Can be used with any 1/4" hex drive bits for easy customizing of bit load
- Available in 12 piece POP display
- Replacement Bit Cartridge (**720559**)



3 position switch for left and right ratcheting or non-ratcheting use



Bits



Shafts



Bit Load

5.5, 6.5 mm Slot
#1, #2 Phillips
#1, #2 Square
1/4" Socket Adapter



Bit storage cartridge concealed in handle



Unique 2-way handle converts from straight to pistol grip for increased torque



Convertible Pistol Grip Ratcheting Screwdriver

720552 / JRSD-9S

- Stubby handle for work in confined spaces
- 3 position switch for left and right ratcheting or non-ratcheting use
- Complete with 6 nickel plated S2 bits and 1/4" socket drive adapter
- Can be used with any 1/4" hex drive bits for easy customizing of bit load
- Available in 12 piece POP display



Bit Load

- 5.5, 6.5 mm slot
- #1 #2 Phillips
- #1 #2 Square
- 1/4" socket adapter

Complete with 6 nickel plated S2 bits and 1/4" socket drive adapter



Bits



Shafts

Stubby handle for work in confined spaces



3 position switch for left and right ratcheting or non-ratcheting use

T-Handle Ratcheting Screwdriver

720556 / JTRSD-21

- Includes interchangeable 2" and 4" shafts for added versatility
- Can be used with any 1/4" hex drive bits for easy customizing of bit load
- Available in 12 piece POP display

Complete with 17 nickel plated S2 bits and 1/4" socket drive adapter



Bits



Shafts

Comfortable T-Handle provides excellent grip and transfer of power



3 position switch for left and right ratcheting or non-ratcheting use



Bit Load

- 4.0, 5.5, 6.5 mm slot
- #1, #2, #3 Phillips
- #1, #2, #3 Square
- T10, T15, T20, T25, T27 TORX*
- 3, 4, 5 mm Hex
- 1/4" Socket Adapter



INSERT BITS



Available in various package quantities to suit any need



IMPACT RATED

- A2 Steel bits are dual heat treated for greatly increased tensile strength
- Allows for more consistent edges and up to 50% greater life than S2 bits
- Heat treated to HRC 58-62
- 1" overall length
- For use with standard or quick release 1/4" hex bit holders
- Canada's strongest and longest lasting bits

Slot

PROD. NO. Tip Size Length Pieces

729112	5/32"	1"	2
729114	5/32"	1"	20
729119	1/4"	1"	2
729121	1/4"	1"	20

A2



Phillips

PROD. NO. Tip Size Length Pieces

729009	PH1	1"	2
729011	PH1	1"	20
729025	PH2	1"	2
729027	PH2	1"	20
729028	PH2	1"	50
729042	PH3	1"	2
729044	PH3	1"	20

A2



Square

PROD. NO. Tip Size Length Pieces

729061	R1	1"	2
729063	R1	1"	20
729078	R2	1"	2
729080	R2	1"	20
729081	R2	1"	50
729095	R3	1"	2
729097	R3	1"	20

A2



Hex

PROD. NO. Tip Size Length Pieces

729303	1/8"	1"	2
729317	5/32"	1"	2
729324	3/16"	1"	2
729331	7/32"	1"	2
729338	1/4"	1"	2
729366	3 mm	1"	2
729373	4 mm	1"	2
729380	5 mm	1"	2
729394	6 mm	1"	2

A2



Magnetic Bit Holders

- For use with insert bits or to extend the reach of power bits
- Powerful magnet holds bit in any position
- Quick release model locks bit in place until ejected

PROD. NO.	MOD. NO.	Type
729483	JMBH-60	Magnetic
729484	JQBH-65	Quick Release Magnetic

A2



TORX

PROD. NO. Tip Size Length Pieces

729163	T8	1"	2
729166	T10	1"	2
729173	T15	1"	2
729180	T20	1"	2
729187	T25	1"	2
729194	T27	1"	2
729201	T30	1"	2
729208	T40	1"	2

A2



- A2 Steel bits are dual heat treated for greatly increased tensile strength
- Allows for more consistent edges and up to 50% greater life than S2 bits
- Heat treated to HRC 58-62
- Available in various package quantities and lengths to suit any need
- 1/4" hex shaft fits ball retainer and regular style chucks
- Canada's strongest and longest lasting bits

Slot

PROD. NO.	Tip Size	Length	Pieces
729115	5/32"	2"	2
729117	5/32"	2"	10
729122	1/4"	2"	2
729124	1/4"	2"	10

A2



Phillips

PROD. NO.	Tip Size	Length	Pieces
729013	PH1	2"	2
729015	PH1	2"	10
729018	PH1	2-3/4"	2
729020	PH1	2-3/4"	10
729022	PH1	6"	1
729029	PH2	2"	2
729031	PH2	2"	10
729032	PH2	2"	25
729034	PH2	2-3/4"	2
729036	PH2	2-3/4"	10
729039	PH2	6"	1
729040	PH2	6"	10
729046	PH3	2"	2
729048	PH3	2"	10
729051	PH3	2-3/4"	2
729056	PH3	6"	1

A2



Square

PROD. NO.	Tip Size	Length	Pieces
729065	R1	2"	2
729067	R1	2"	10
729070	R1	2-3/4"	2
729072	R1	2-3/4"	10
729075	R1	6"	1
729082	R2	2"	2
729084	R2	2"	10
729085	R2	2"	25
729087	R2	2-3/4"	2
729089	R2	2-3/4"	10
729092	R2	6"	1
729093	R2	6"	10
729099	R3	2"	2
729101	R3	2"	10
729104	R3	2-3/4"	2
729109	R3	6"	1

A2



Hex

PROD. NO.	Tip Size	Length	Pieces
729306	1/8"	2"	2
729320	5/32"	2"	2
729327	3/16"	2"	2
729334	7/32"	2"	2
729341	1/4"	2"	2
729369	3 mm	2"	2
729376	4 mm	2"	2
729383	5 mm	2"	2
729397	6 mm	2"	2

A2



TORX

PROD. NO.	Tip Size	Length	Pieces
729169	T10	2"	2
729176	T15	2"	2
729183	T20	2"	2
729190	T25	2"	2
729197	T27	2"	2
729204	T30	2"	2
729211	T40	2"	2

A2



NUTSETTERS

- Powerful magnet holds fastener securely for use in any position
- Heat treated Chrome Vanadium steel for professional use
- 1/4" hex shaft fits ball retainer and regular style chucks



SAE CrV Steel

PROD. NO.	Tip Size	Pieces
729461	1/4"	1
729462	5/16"	1
729463	3/8"	1

CrV

Metric CrV Steel

PROD. NO.	Tip Size	Pieces
729471	6 mm	1
729472	7 mm	1
729473	8 mm	1
729475	10 mm	1

CrV



Hollow shafts allow running nuts on long fasteners



CUSHION GRIP NUT DRIVERS - SETS

- Chrome Vanadium steel for professional use
- Hardened and tempered for superior strength and improved durability
- Super strong acetate handles resist impact and chemicals
- Integrated cushion grips provide all day comfort and increased torque
- Chrome plated for superior corrosion resistance
- Hex bolster allows use of a wrench for increased torque
- Hollow shaft fits over long fasteners
- Socket size permanently embossed on handles for easy identification in tool pouch
- Convenient plastic carrying case keeps nut drivers organized

7 PC SAE Cushion Grip Nut Driver Set

721101 / JKND-7S

3/16", 1/4", 5/16", 11/32", 3/8", 7/16", 1/2"



7 PC Metric Cushion Grip Nut Driver Set

721102 / JKND-7M

6, 7, 8, 9, 10, 11, 12 mm



CUSHION GRIP NUT DRIVERS - OPEN STOCK

SAE		Metric	
PROD. NO.	Size	PROD. NO.	Size
721141	3/16" x 3	721151	6 mm x 3
721142	1/4" x 3	721152	7 mm x 3
721143	5/16" x 3	721153	8 mm x 3
721144	11/32" x 3	721154	9 mm x 3
721145	3/8" x 3	721155	10 mm x 3
721146	7/16" x 3	721156	11 mm x 3
721147	1/2" x 3	721157	12 mm x 3





721111

JUMBO HANDLE SERIES - SET

- Jumbo grip grooved handle design ensures maximum torque for tough jobs
- Made with super acetates, these handles are virtually indestructible
- Hollow Chrome Vanadium shafts

7 PC SAE - Hollow Shaft

721105 / NDS-07

3/16, 1/4, 5/16, 11/32, 3/8, 7/16, 1/2"

- Roll up pouch

6 CrV

721105

JUMBO HANDLE SERIES - OPEN STOCK

SAE - Hollow Shaft

PROD. NO.	MOD. NO.	Size	Length	Point
721111	ND-316	3/16"	3-1/2"	6
721112	ND-14	1/4"	3-1/2"	6
721113	ND-516	5/16"	3-1/2"	6
721114	ND-1132	11/32"	3-1/2"	6
721115	ND-38	3/8"	3-1/2"	6
721116	ND-716	7/16"	3-1/2"	6
721117	ND-12	1/2"	3-1/2"	6

6 CrV



720542



720546



PRECISION SCREWDRIVER - SETS

- Ergonomic bi-material handles for sure grip
- Rotating cap allows easy one hand operation
- Chrome Vanadium steel shafts
- Convenient plastic case

6 PC Slot / Phillips Set

720542 / JPSP-6

Slot Phillips 

2.0, 3.0, 4.0

#00, #0, #1

CrV

6 PC TORX® Set

720546 / JPSP-6T

TORX® 

T5, T6, T7, T8, T9, T10

CrV

IMPACT DRIVER

1/2" Drive

720702 / JID-5S

- Premium grade high carbon steel body withstands high impact forces
- Entirely heat treated for maximum strength
- S2 steel bits for professional use
- Drives 5/16" shank screwdriver bits and 1/2" drive impact sockets
- Reversible for installing or removing fasteners
- Ideal for removing rusted fasteners
- Includes 5/16" and 3/8" slot and #2 and #3 Phillips bits

Replacement 4 piece bit set **720791**



720702

**PLIERS
CUTTERS
SHEET METAL TOOLS**





LOCKING PLIERS - OPEN STOCK

- Made of Chrome Molybdenum steel for added durability
- Heat treated handles, pins and jaws
- Nickel plated finish resists corrosion
- Strong locking mechanism with welded seams for strength under load
- Ergonomic cushioned release lever is guarded to prevent accidental release
- All locking pliers come with wire cutter in jaw
- Meets ANSI requirements



730338

5 PC Locking Pliers Set

PROD. NO.	MOD. NO.	Pieces	Length	Type
730338	JLPS-5	5	5", 7", 10", 7", 9"	Curved Jaw / 5", 7", 10" Long Nose / 7", 9"

CrMo

Locking Pliers - Open Stock

PROD. NO.	MOD. NO.	Length	Type
730452	JLP-5C	5"	Curved Jaw
730454	JLP-7C	7"	Curved Jaw
730457	JLP-10C	10"	Curved Jaw
730464	JLP-7L	7"	Long Nose
730466	JLP-9L	9"	Long Nose

CrMo



Curved Jaw

Teeth raked to provide superior non-slip grip



- Exclusive 9254 steel jaw components offer increased core strength over Chrome Molybdenum or Chrome Vanadium jaws
- Jaw hardness increases below the surface allowing for increased clamping pressure and offering longer tooth life
- Precision ground jaws with backward raked teeth for superior grip
- All models complete with wire cutter
- Cushioned release lever is guarded to prevent accidental release
- Handles made of top quality Chrome Molybdenum steel – much stronger than carbon steel handles used on the leading brand
- Stronger handle steel prevents rivet holes from enlarging over time, leading to rivet failure
- Exceeds ANSI requirements and industry standards

Chrome Molybdenum steel handles



Exclusive 9254 Steel Jaw

YOU CAN'T BUY A BETTER, STRONGER LOCKING PLIERS



730336



730335

Locking Pliers Sets - Super Heavy Duty

PROD. NO.	MOD. NO.	Pieces	Length	Type
730336	LPS-3	3	6", 7", 10"	Curved Jaw / 7", 10" Long Nose / 6"
730335	LPS-5	5	5", 7, 10", 6", 9"	Curved Jaw / 5", 7", 10" Long Nose / 6", 9"



Locking Pliers - Open Stock

PROD. NO.	MOD. NO.	Length	Type
730453	J5WR	5"	Curved Jaw
730455	J7WR	7"	Curved Jaw
730456	J7WRG	7"	Curved Jaw / PVC Grip
730458	J10WR	10"	Curved Jaw
730459	J10WRG	10"	Curved Jaw / PVC Grip
730462	J4LN	4"	Long Nose
730463	J6LN	6"	Long Nose
730467	J9LN	9"	Long Nose



PVC Grip



Long Nose

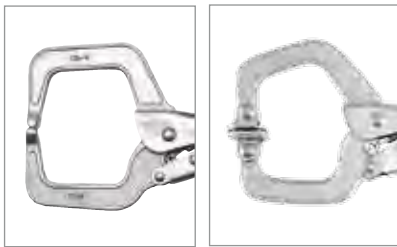

730496

730554, 730556
C-Clamp730555, 730557
C-Clamp with Pads730558
Sheet Metal730559
Welders

LOCKING PLIERS - OPEN STOCK

Chain Wrench

730496 / J20R

- 20" chain
- Made of industrial quality Chrome Molybdenum steel
- Strong locking mechanism
- Ergonomic cushioned release lever is guarded to prevent accidental release
- Meets ANSI requirements
- Quality equal to the best!

CrMo

Locking Clamps - Open Stock

- Chrome Vanadium and Chrome Molybdenum jaw components for improved strength
- C-Clamps available with your choice of plain tips or swivel pads
- New heavy duty material for improved performance and life

PROD. NO.	MOD. NO.	Length	Type
730554	J6R	6"	C-Clamp
730555	J6RP	6"	C-Clamp with Pads
730556	J11R	11"	C-Clamp
730557	J11RP	11"	C-Clamp with Pads
730558	J8R	8"	Sheet Metal
730559	J9R	9"	Welders

CrMo CrV



730555

SNAP RING PLIERS - SETS

- Cushion grip handles
- Made of carbon steel
- Spring loaded handles



5 PC Interchangeable Tips

PROD. NO.	MOD. NO.	Length	Type
730352	SRP-1S	6"	Straight tips, Bent tips, Convertible type



730352

4 PC Permanent Tips

PROD. NO.	MOD. NO.	Length	Type
730353	SRP-4S	7"	Internal Straight, External Straight, Internal Bent, External Bent



730353

SNAP RING PLIERS - OPEN STOCK

Internal Type

PROD. NO.	MOD. NO.	Length	Type
730701	SRP-175IS	7"	Internal Straight
730702	SRP-175IB	7"	Internal Bent



730701

730702

External Type

PROD. NO.	MOD. NO.	Length	Type
730703	SRP-175ES	7"	External Straight
730704	SRP-175EB	7"	External Bent



730703

730704



CHROME VANADIUM - SETS

- Made of high quality Chrome Vanadium steel (except slip joint)
- Cutting edges induction hardened to HRC58-62
- Double-dipped cushion grip handles offer superior comfort, sure gripping action and long life



730311

4 PC Starter Pliers Set

730311 / JPS-4N

- **6-1/2"** Diagonal Cutter
- **6-1/2"** Long Nose
- **7"** Lineman's
- **8"** Slip Joint

CrV



730321

5 PC Maintenance Set

730321 / JPS-5

- **8"** Long Nose
- **8"** Diagonal Cutter
- **8"** Lineman's
- **8"** Slip Joint
- **8"** Bent Nose

CrV



730341

5 PC Mechanics Pliers Set

730341 / JPS-5M

- **8"** Angle Head Cutter
- **8"** Long Nose
- **8"** Lineman's
- **8"** Slip Joint
- **10"** Groove Joint

CrV

CHROME VANADIUM - OPEN STOCK



- Made of high quality Chrome Vanadium steel (except Slip Joint)
- Cutting edges induction hardened to HRC58-62
- Double-dipped cushion grip handles offer superior comfort, sure gripping action and long life

Slip Joint Pliers

- Made of quality Carbon steel

PROD. NO.	MOD. NO.	Length
730401	PL-6	6"
730402	PL-8	8"
730403	PL-10	10"



Groove Joint Pliers

PROD. NO.	MOD. NO.	Length	Capacity
730441	CLP-1	7-1/2"	1-1/4"
730442	CLP-2	9-1/2"	1-3/4"
730443	CLP-3	12"	2-1/4"
730445	CLP-4	16"	4"



Long Nose Pliers

PROD. NO.	MOD. NO.	Length
730423	RP-150	6-1/2"
730425	RP-200	8"



Bent Nose Pliers

PROD. NO.	MOD. NO.	Length
730483	BP-150	6-1/2"
730485	BP-200	8"



LONG REACH SERIES - OPEN STOCK

Long Nose Style

PROD. NO.	MOD. NO.	Length	Type
730428	LRP-1100	11"	Long Nose
730488	LRP-1145	11"	Bent Nose



730401 - 730403



730442



730425



730483



730428

730488



730415



730433



730221

Angle head
730221 only

730473



730232



735102

CHROME VANADIUM - OPEN STOCK

Lineman's Pliers

PROD. NO.	MOD. NO.	Length
730414	CP-175	7"
730415	CP-200	8"
730418	CP-250HD	9-3/4"

CrV

Diagonal Cutting Pliers

- Unique shape and head configuration for best leverage and easiest cutting capabilities

PROD. NO.	MOD. NO.	Length	Type
730433	NP-150	6-1/2"	Diagonal Cutter
730435	NP-200	7-1/2"	Diagonal Cutter
730221	NPA-200HD	8"	Angle Head Cutter

CrV

Crimping Pliers

730473 / WP-250HD

- 10" long
- A heavy duty cutter and crimping tool
- Not for use on live circuits

CrNi

Box Joint Pliers

730232 / BJP-250HD

- 10" long
- Chrome Vanadium steel
- Special jaw design for use on pipe
- Unique box joint adjusting system allows quick and easy one hand adjustments

CrV

10" Fencing Pliers

735102 / FT-10X

- Drop forged steel with blue cushion grip handles
- Ideal multi-purpose pliers for farmers and ranchers
- Hammer, staple remover and 2 wire cutters in 1 tool
- Length 10"

5 PC Chrome Nickel Pliers Set – Super Heavy Duty 730305 / JPHD-5S

- Highest grade Chrome Nickel steel drop forged for ultimate strength
- Induction hardened teeth and exclusive laser hardened cutting edges for superior performance and long life
- Unique laser hardening process allows cutting of hardened materials including piano wire
- Patented high leverage design moves pivot point forward for increased cutting power and ease of use
- Handle springs on Lineman's, Diagonal Cutting, Bent Nose and Long Nose pliers open handles automatically, reducing fatigue and are easily removed if preferred
- Groove joint pliers feature undercut machined tongue and groove for greater strength at all jaw widths
- Right-angle teeth for superior grip
- Extra thick dual material handles provide unparalleled grip and user comfort
- Meets ANSI specifications

Induction Hardened Teeth

High Leverage Design
Laser Hardened Cutting Edge
Spring Loaded Handles
Induction Hardened Teeth



Induction Hardened Teeth

FEATURES

High Leverage Design

Patented High Leverage design moves pivot point forward for increased cutting power and ease of use

Laser Hardened Cutting Edge

Unique laser hardening process allows cutting of hardened materials including piano wire

Spring Loaded Handles

Handle springs on Linemans, Diagonal Cutting, and Long Nose pliers open handles automatically, reducing fatigue. Easily removed if preferred

Induction Hardened Teeth

Induction hardened right angle teeth for superior performance and long life

High Leverage Design
Laser Hardened Cutting Edge
Spring Loaded Handles





730241



730246

CHROME NICKEL SERIES - OPEN STOCK

Lineman's Pliers

- Unique laser hardening process allows cutting of hardened materials including piano wire
- Right angle teeth induction hardened to HRC55~60 for maximum grip
- Spring loaded handles reduce fatigue; spring can be easily removed and replaced if preferred

PROD. NO.	MOD. NO.	Length
-----------	----------	--------

730236	CP-200HD	8"
--------	----------	----

CrNi

Diagonal Cutting Pliers

- Unique laser hardening process allows cutting of hardened materials including piano wire
- Spring loaded handles reduce fatigue; spring can be easily removed and replaced if preferred

PROD. NO.	MOD. NO.	Length
-----------	----------	--------

730222	NP-180HD	7-1/4"
--------	----------	--------

CrNi

Long Nose Pliers

- Unique laser hardening process allows cutting of hardened materials including piano wire
- Right angle teeth induction hardened to HRC55~60
- Spring loaded handles reduce fatigue; spring can be easily removed and replaced if preferred

PROD. NO.	MOD. NO.	Length
-----------	----------	--------

730241	RP-200HD	8"
--------	----------	----

CrNi

Bent Nose Pliers

PROD. NO.	MOD. NO.	Length
-----------	----------	--------

730246	BP-200HD	8"
--------	----------	----

CrNi





Groove Joint Pliers

- Features undercut machined tongue and groove for maximum strength at all jaw widths
- Right angle teeth induction hardened to HRC55~60 for maximum grip

PROD. NO.	MOD. NO.	Length
730216	CLP-1HD	8"
730217	CLP-2HD	10"
730218	CLP-3HD	12"

CrNi



730217



Slip Joint Pliers

- Right angle teeth induction hardened to HRC55~60 for maximum grip

PROD. NO.	MOD. NO.	Length
730206	SJ-6HD	6"
730207	SJ-8HD	8"

CrNi



720206



End Nipper Pliers

- Ideal for flush cutting and concrete work

PROD. NO.	MOD. NO.	Length
730227	EN-200HD	8"

CrNi



730227



Cable Cutter

- For copper and aluminum cables only
- Maximum AWG 1 cable gauge

PROD. NO.	MOD. NO.	Length
730251	CC-200HD	8"

CrNi



730251





735252



735256



735275

SHEARS - SUPER HEAVY DUTY

- Top grade Japanese stainless steel for professional applications.
- Designed for left or right hand use.
- Vacuum heat treated for superior cutting edge and long life.

Multi-Purpose Shears - Super Heavy Duty

- Serrated blades prevent material from being pushed forward, making cutting easier and more accurate
- Hardened stainless steel nut and bolt for adjustable tension
- Dual material Polypropylene and Thermoplastic Rubber handles for strength and secure grip
- Suitable for cutting branches, dowels, cardboard, rope, cord, wire, and many other materials

PROD. NO.	MOD. NO.	Overall Length	Cutting Length	Type
735252	JMPS-145	5-3/4"	1-1/4"	Straight
735253	JMPS-190	7-1/2"	1-5/8"	Straight
735254	JMPS-190A	7-1/4"	1-5/8"	Angled
735255	JMPS-200	8"	2"	Straight
735256	JMPS-200A	8"	2"	Angled



8" Utility Shears - Super Heavy Duty

- High leverage design transmits power more efficiently for easier cutting
- Suitable for cutting thick cloth, upholstery, leather, rubber, vinyl, fabric, rope, cardboard, paper, poultry and many other materials
- Thermoplastic elastomer handles are tough, pliable, and comfortable to use

PROD. NO.	MOD. NO.	Overall Length	Cutting Length	Type
735275	JUS-200	8"	2-1/2"	Straight



- Top grade Japanese stainless steel for professional applications.
- Designed for left or right hand use.
- Vacuum heat treated for superior cutting edge and long life.

Electrician's - Super Heavy Duty

- Hollow ground blades requires less cutting effort
- Serrated blade prevents material from being pushed forward, making cutting easier and more accurate
- Dedicated wire stripping notch
- Fibreglass reinforced nylon handles with thermoplastic rubber overmould for superior strength and grip
- Suitable for cutting soft cable, insulation, electrical tape, cable ties and many other materials

PROD. NO	MOD. NO.	Overall Length	Cutting Length	Wire Cutter Notch
735262	JECS-140	5-1/2"	1-5/8"	yes



Kevlar® Shears - Super Heavy Duty

- Specially selected high carbon alloy steel for use on Kevlar® materials
- Cutting edges induction hardened to HV1200
- Hollow ground blades requires less cutting effort
- Serrated blade prevents material from being pushed forward, making cutting easier and more accurate
- Fibreglass reinforced nylon handles with thermoplastic rubber overmould for superior strength and grip
- Suitable for cutting Kevlar®, insulation materials, electrical tape, cable ties, and many other materials

PROD. NO	MOD. NO.	Overall Length	Cutting Length
735264	JECS-140K	5-1/2"	1-5/8"





WIRE STRIPPERS AND CUTTERS



Automatic Wire Stripper

730731 / JAWS-822

- One quick light squeeze strips wire up to a full 1" without nicking, cutting or fraying
- Automatic wire gripper holds wire centered in stripping hole
- Lever action offers stripping and insulation removal in one step
- Adjustable wire stop to ensure uniform, precise strip length
- Overall Length **7"**
- Stripping Capacity: **8, 10, 12, 14, 16, 18, 20, 22** AWG solid and stranded



V-Groove Wire Stripper

730738 / JWVS-51024

- Hardened carbon steel with black oxide finish for corrosion resistance
- Quickly adjusts from **AWG 10 to 24**
- Spring loaded for easy one hand use
- Overall length **5-1/4"**
- Capacity: **10, 12, 14, 16, 18, 20, 22, 24** AWG solid and stranded



Self-Adjusting Wire Stripper

730736 / JAWS-100

- Self adjusting stripper automatically applies correct pressure to strip insulation without nicking wire
- Fine adjustment insulation
- Can be used to strip several wires simultaneously
- Includes wire cutter
- Overall length **6-1/2"**



Spring Loaded Strippers / Cutters

- All cutting and stripping surfaces are precision machined to produce clean, exacting results
- High carbon heat treated steel for long life
- Black oxide finish resists rust and corrosion
- All models feature holes for looping and serrated tips for pulling wire
- Strippers / cutters are spring loaded for easy one hand operation and have safety lock (except 730724)
- Multifunction tools cut, strip and crimp insulated and non-insulated terminals
- For use on copper and aluminum wire only

730725

730724

730711

PROD. NO.	MOD. NO.	Overall Length	Stripping Capacity	Crimping Capacity	Bolt Size & Thread
730711	JWCS-61020	6-1/4"	10, 12, 14, 16, 18, 20 AWG solid and stranded	N/A	N/A
730724	JMWS-81024	8-1/4"	8, 10, 12, 14, 16, 18, 20, 22 AWG solid 12, 14, 16, 18, 20, 22, 24, 26 AWG stranded	10-22 AWG	4-40, 5-40, 6-32, 8-32, 10-32, 10-24
730725	JMWS-9618	9"	6, 8, 10, 12, 14, 16 AWG solid 8, 10, 12, 13, 16, 18 AWG stranded	10-22 AWG	4-40, 5-40, 6-32, 8-32, 10-32, 10-24



INTRODUCING OUR
NEW KNIVES



A CUT ABOVE.



CUTTING TOOLS

**9 mm Snap-Off Utility Knife****840433** / JSBK-9

- Ergonomic over-mould rubber grip for added comfort and safety
- Slide lock blade advance holds securely for extended use
- Includes SK5 high carbon steel blade

NEW**18 mm Snap-Off Utility Knife****840432** / JSBK-18

- Ergonomic over-mould rubber grip for added comfort and safety
- Slide lock blade advance holds securely for extended use
- Includes SK5 high carbon steel blade

NEW**25 mm Jumbo Snap-Off Utility Knife****840431** / JSBK-25

- Ergonomic over-mould rubber grip for added comfort and safety
- Dial lock blade advance holds securely for extended use
- Integrated magnet for easy blade retrieval
- Includes one SK5 high carbon steel blade

NEW

9 mm Auto-Load Snap-Off Utility Knife

840442 / JALK-9

- Ergonomic non-slip rubber grip for added comfort and safety
- Easy to use slide-lock blade advance locks blade automatically
- Integrated blade storage ejects and reloads blades quickly
- Includes five SK5 high carbon steel blades

NEW**18 mm Auto-Load Snap-Off Utility Knife**

840441 / JALK-18

- Ergonomic non-slip rubber grip for added comfort and safety
- Easy to use slide-lock blade advance locks blade height automatically
- Integrated blade storage ejects and reloads blades quickly
- Includes five SK5 high carbon steel blades

NEW**Folding Utility Knife - Heavy Duty**

840411 / JFFK-100

- Durable all-metal construction for the toughest work environments
- Dual locking handle (open and closed) with integrated belt clip keeps user safe, and the knife stored securely
- Titanium coated SK5 steel blade resists corrosion and extends blade life

NEW**Safety Box Cutter**

840401 / JSBC-100

- Features a tape punch that will not damage contents, and a shielded cutting wheel for plastic strapping
- Extremely lightweight, designed with comfortable rubber grip

NEW

REPLACEMENT BLADES

PROD. NO.	MOD. NO.	DESCRIPTION	FOR PRODUCTS
840481	JFRB-10	10 PC Utility Knife Blades	840411, 840421, 840422
840482	JFRB-10T	10 PC Titanium Coated Utility Knife Blades	840411, 840421, 840422
840486	JFRB-50	50 PC Utility Knife Blades	840411, 840421, 840422
840488	JFRB-100	100 PC Utility Knife Blades	840411, 840421, 840422
840491	JSRB-2510	10 PC - 25 mm Utility Knife Blades	840431
840494	JSRB-910	10 PC - 9 mm Utility Knife Blades	840442, 840433
840497	JSRB-1850	50 PC - 18 mm Utility Knife Blades	840441, 840432



840481

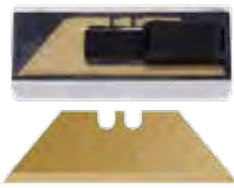

840482



840488



840492



840486



840497

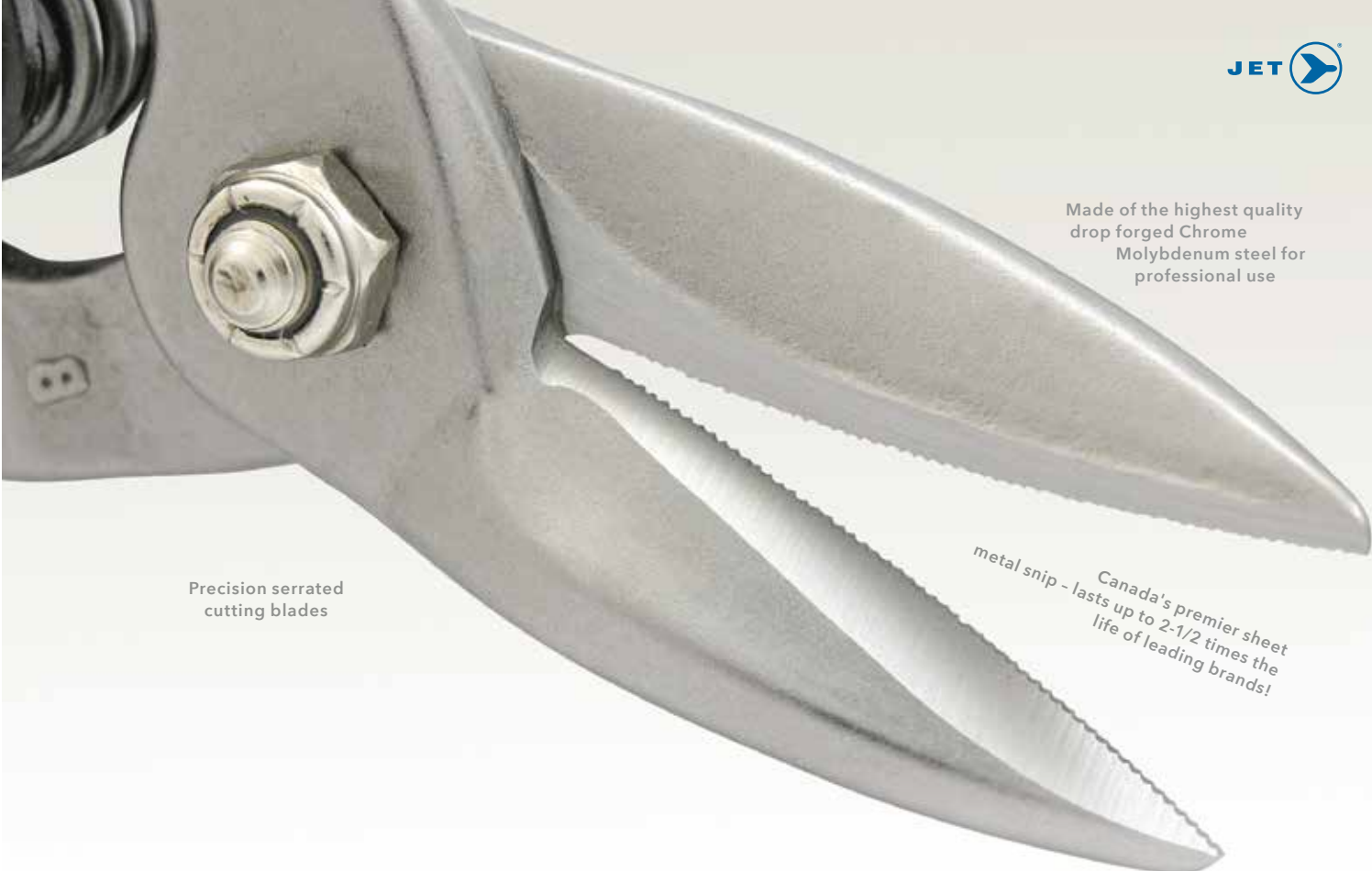

Precision serrated cutting blades

Made of the highest quality drop forged Chrome Molybdenum steel for professional use

Canada's premier sheet metal snip - lasts up to 2-1/2 times the life of leading brands!

SHEET METAL TOOLS

AVIATION SNIPS - SUPER HEAVY DUTY

- Made of the highest quality drop forged Chrome Molybdenum steel for professional use
- Induction hardened to HRC 60 – 62
- Serrated cutting edges prevent material from slipping out of blade
- Compound action reduces cutting effort
- Colour coded TPR handles provide maximum comfort
- Unique automatic release latch for easy one hand operation
- Regular, offset, notching and extra long models cover every application



735305

3 PC Traditional Style Set

PROD. NO.	MOD. NO.	Description	Overall Length
735305	JAS-3S	Straight cut, Left cut and Right cut	10"



Traditional Style - Open Stock

PROD. NO.	MOD. NO.	Description	Overall Length	Length to Cut	MAXIMUM MATERIAL THICKNESS (GAUGE)			
					Copper (soft)	Cold Rolled Steel (med.)	Hard Steel (HRC35)	304 Stainless Steel
735301	JAS-1S	Straight	10"	1-1/2"	16	18	21	22
735302	JAS-1R	Right Cut	10"	1-3/8"	16	18	21	22
735303	JAS-1L	Left Cut	10"	1-3/8"	16	18	21	22
735311	JAS-1SL	Long Cut	11-3/8"	3"	19	20	22	25
735391	JBS-1	Bulldog	9"	1"	14	16	18	18

CrMo



735303

735301

735302

735311

735391

735322

735323

Offset Style - Open Stock

PROD. NO.	MOD. NO.	Description	Overall Length	Length to Cut	MAXIMUM MATERIAL THICKNESS (GAUGE)			
					Copper (soft)	Cold Rolled Steel (med.)	Hard Steel (HRC35)	304 Stainless Steel
735322	JOS-1R	Right Cut	9-1/4"	1-3/16"	16	18	21	22
735323	JOS-1L	Left Cut	9-1/4"	1-3/16"	16	18	21	22

CrMo

10" Tin Snip

735210 / JTS-10

- Made of drop forged high carbon steel
- One piece solid steel construction
- Smooth finished blades for cleaner cutting

Overall Length	Length to Cut	MAXIMUM MATERIAL THICKNESS (GAUGE)			
		Copper (soft)	Cold Rolled Steel (med.)	Hard Steel (HRC35)	304 Stainless Steel
10"	2"	20	22	24	26



RIVET TOOLS

- Designed for industrial use
- All steel construction
- All models designed for use with aluminum rivets
- 859044 (JRT-707) for use with aluminum and steel rivets
- 859043 (JRT-736) features 360° swivel head

Hand Riveters - Heavy Duty

PROD. NO.	MOD. NO.	Description	Nozzles	Length (Overall)
859042	JRT-200	Long Nose	3/32, 1/8, 5/32, 3/16"	—
859043	JRT-736	Swivel Head 360°	3/32, 1/8, 5/32, 3/16"	—
859044	JRT-707	Long Reach, use with aluminum and steel rivets	1/8, 5/32, 3/16, 7/32, 1/4"	21"
—	PUT-JRT707	Repair Kit	—	—

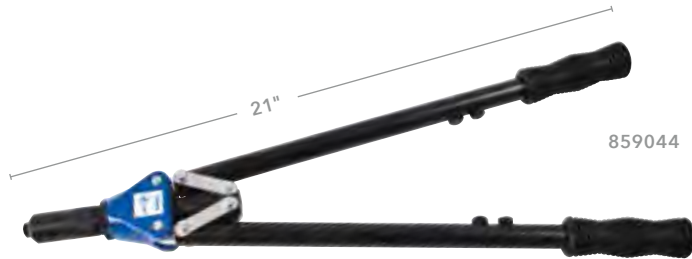

859042

859043



Did you Know?
JET Carries a complete line of professional pneumatic rivet guns. See our AIR TOOLS section for details





VDE TOOLS





VDE TOOLS

- Electrically shielded tools for use on live circuits
- Individually tested and VDE certified to 1,000 V for maximum user protection
- Co-moulded polypropylene and thermoplastic vulcanizates ensure maximum strength balanced with superior non-slip grip
- Resistant to most chemicals, solvents, and oil
- Use on service panels, switch boxes, electric and hybrid automobiles, or anytime work must be performed while circuit is potentially live
- All items meet IEC60900:2004 standards

VDE TOOL KITS

10 PC Tool Kit

760002 / JITK-10S

- Contains most commonly used VDE screwdrivers and pliers
- Includes case



PROD. NO.	MOD. NO.	Includes
760213	JISS-5	7/32" x 5" Slot
760214	JISS-6	1/4" x 6" Slot
760236	JISR-2	#2 Square
760224	JISP-1	#1 Phillips
760226	JISP-2	#2 Phillips
760341	JIWS-6	6" Wire Stripper
760312	JILP-8	8" Lineman's Pliers
760322	JILN-8	8" Long Nose Pliers
760332	JINP-8	8" Diagonal Cutter
760352	JIWP-10	10" Water Pump Pliers

CrV

SVCM

9 PC Screwdriver Set

760202 / JISD-9S

- Includes pouch

PROD. NO.	MOD. NO	Includes
760211	JISS-4	5/32" x 4" Slot
760213	JISS-5	7/32" x 5" Slot
760214	JISS-6	1/4" x 6" Slot
760221	JISP-0	#0 Phillips
760224	JISP-1	#1 Phillips
760226	JISP-2	#2 Phillips
760228	JISP-3	#3 Phillips
760234	JISR-1	#1 Square
760236	JISR-2	#2 Square

SVCM

5 PC Nut Driver Set

770302 / JIND-5S

- Includes pouch

PROD. NO.	MOD. NO	Includes
760262	JIND-14	1/4" Nut Driver
760263	JIND-516	5/16" Nut Driver
760265	JIND-38	3/8" Nut Driver
760266	JIND-716	7/16" Nut Driver
760267	JIND-12	1/2" Nut Driver

CrV





VDE SCREWDRIVERS - OPEN STOCK

- Two layers of insulation provide ultimate protection
- Unique handle design conforms to the hand for exceptional comfort and grip
- Pentagon shaped neck bolster minimizes roll away
- Tip size and style on handle ends for easy identification in tool pouch
- Patented SVCM tool steel is up to 30% stronger than CrV screwdrivers
- Phosphate plated tips will not chip or peel
- **Warning:** If yellow layer is exposed through the red layer, tool has been damaged and should be retired

Slot Screwdrivers

PROD. NO.	MOD. NO.	Size
760211	JISS-4	5/32" x 4"
760213	JISS-5	7/32" x 5"
760214	JISS-6	1/4" x 6"



SVCM

Phillips Screwdrivers

PROD. NO.	MOD. NO.	Size
760221	JISP-0	#0
760224	JISP-1	#1
760226	JISP-2	#2
760228	JISP-3	#3



SVCM

Square Screwdrivers

PROD. NO.	MOD. NO.	Size
760234	JISR-1	#1
760236	JISR-2	#2



SVCM



760224

760213



- Two layers of insulation provide ultimate protection
- Unique handle design conforms to the hand for exceptional comfort and grip
- Pentagon shaped neck bolster minimizes roll away
- Size printed on handle ends for easy identification in tool pouch
- Chrome Vanadium steel for professional use
- **Warning:** If yellow layer is exposed through the red layer, tool has been damaged and should be retired

Nut Drivers

PROD. NO.	MOD. NO.	Size
760262	JIND-14	1/4"
760263	JIND-516	5/16"
760265	JIND-38	3/8"
760266	JIND-716	7/16"
760267	JIND-12	1/2"



VDE PLIERS AND CUTTERS - OPEN STOCK

- Drop forged Chrome Vanadium steel with induction hardened cutting edges
- Handle bolster for positive stop between insulated handle and non-insulated steel components

Pliers and Cutters

PROD. NO.	MOD. NO.	Description
760341	JIWS-6	6" Wire Stripper
760312	JILP-8	8" Lineman's Pliers
760322	JILN-8	8" Long Nose Pliers
760332	JINP-8	8" Diagonal Cutter
760352	JIWP-10	10" Water Pump Pliers



760267



PIPE TOOLS





710145



710245

PIPE WRENCHES

Steel - Heavy Duty

- Hardened Chrome Vanadium steel hook and heel jaws for professional applications
- Induction hardened teeth provide exceptional grip
- Powder coat paint for protection against corrosion
- Heel jaw attached with roll pin for easy replacement
- Meets US Federal Government Specification GGG-651 type II Class A

PROD. NO.	MOD. NO.	Length	Jaw Capacity
710142	JPW-8	8"	1"
710143	JPW-10	10"	1-1/2"
710144	JPW-12	12"	2"
710145	JPW-14	14"	2"
710147	JPW-18	18"	2-1/2"
710150	JPW-24	24"	3"
710156	JPW-36	36"	5"
710159	JPW-48	48"	6"



Aluminum - Heavy Duty

- Hardened Chrome Vanadium steel hook and heel jaws for professional applications
- Induction hardened teeth provide exceptional grip
- Aluminum handle is up to 40% lighter than steel handles
- Heel jaw attached with roll pin for easy replacement
- Meets US Federal Government Specification GGG-651 type I Class B.10

PROD. NO.	MOD. NO.	Length	Jaw Capacity
710245	JPWA-14	14"	2"
710247	JPWA-18	18"	2-1/2"
710250	JPWA-24	24"	3"
710256	JPWA-36	36"	5"
710259	JPWA-48	48"	6"



PIPE WRENCHES

Steel - Super Heavy Duty

- Super Heavy duty cast steel handles for professional use
- Extra heavy cast head design is 20% stronger than competitive brands
- **Chrome Molybdenum** hook and heel jaws for longest life and maximum grip
- Jaws hardened to HRC 52 – 58
- Powder-coated for maximum resistance to corrosion
- Induction hardened teeth provide exceptional grip
- Heel jaws attached using roll pins for easy replacement
- Meets US Federal Government Specification GGG-651 type II Class A

PROD. NO.	MOD. NO.	Length	Jaw Capacity
710122	PW-8	8"	1-3/16"
710123	PW-10	10"	1-13/16"
710124	PW-12	12"	2-7/16"
710125	PW-14	14"	2-7/16"
710127	PW-18	18"	2-7/8"
710130	PW-24	24"	3-3/16"
710136	PW-36	36"	5-1/4"



Aluminum - Super Heavy Duty

- Heavy duty lightweight aluminum handles for professional use
- Extra heavy duty cast head design is 20% stronger than competitive brands
- **Chrome Molybdenum** hook and heel jaws for longest life and maximum grip
- Jaws hardened to HRC 52 - 58
- Powder-coated for maximum resistance to corrosion
- Induction hardened teeth provide exceptional grip
- Heel jaws attached using roll pins for easy replacement
- Meets US Federal Government Specification GGG-651 type I Class B-10

PROD. NO.	MOD. NO.	Length	Jaw Capacity
710225	PWA-14	14"	2-7/16"
710227	PWA-18	18"	2-7/8"
710230	PWA-24	24"	3-3/16"
710236	PWA-36	36"	5-1/4"
710239	PWA-48	48"	6"



710124



710227



TUBE CUTTERS



H1179



739109

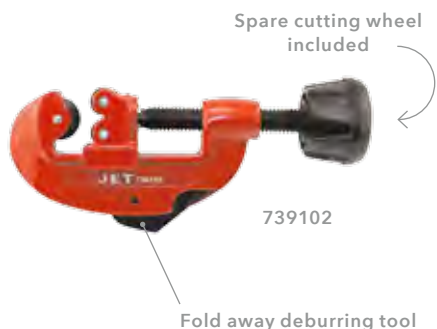

Spare cutting wheel included

739102

Fold away deburring tool



Spare cutting wheel included

739104

Mini Tube Cutters

- Compact overall size for use where space is restricted
- Cuts copper, brass, aluminum and thin wall steel conduit
- Hardened steel cutting wheel for copper cutting
- Replacement cutters: **739191** copper, **739193** stainless steel

PROD. NO.	MOD. NO.	Capacity	Replacement Cutters
H1179	-	1/8" - 5/8" O.D.	739191 copper, 739193 stainless steel
739109	JMTC-30	1/8" - 1-1/8" tubing (3 - 30 mm)	739192 copper, 739194 stainless steel

1-1/8" Screw Feed Tube Cutter

739102 / JTC-30

- Cuts copper, brass, aluminum and thin wall steel conduit
- Cuts **1/8" - 1-1/8"** (3 - 30 mm) tubing
- Grooved rollers allow cutting close to flare
- One piece sliding block for longest life and accurate cuts
- Includes fold away deburring tool
- Contoured adjustment knob houses spare cutting wheel
- Hardened steel cutting wheel for copper cutting
- Replacement cutters: **739191** copper, **739193** stainless steel

Telescopic Tube Cutter

- Telescopic cutter requires no additional room to open to full capacity
- Cuts copper, brass, aluminum and thin wall steel conduit
- Grooved rollers allow cutting close to flare
- Hardened steel cutting wheel for copper cutting
- Includes spare cutting wheel for copper cutting

PROD. NO.	MOD. NO.	Capacity	Replacement Cutters
739104	JTTC-32	1/8" - 1-1/4"	739191 copper, 739193 stainless steel

TUBE CUTTERS



2" Quick Adjustable Tube Cutter

739107 / JOAC-50

- Spring loaded cutter wheel feed system allows slide action adjustment and quick release
- Cuts copper, brass, aluminum and thin wall steel conduit
- Cuts **1/4 – 2"** (6 – 50 mm) tubing
- Grooved rollers allow cutting close to flare
- Hardened steel cutting wheel for copper cutting
- Includes fold away deburring tool
- Contoured adjustment knob houses spare cutting wheel
- Replacement cutters: **739192** copper, **739194** stainless steel

Quick adjust slide action cutter arm

Spare cutting wheel included



1-1/8" Ratchet Tube Cutter

739108 / JRTC-28

- Ratchet action cutter allows cutting of tubes without having to rotate 360°
- Open end design is ideal for cutting sections of pipe in walls and other limited access areas
- Simply close cutter on tube and move back and forth until cut is made
- Cuts **5/16 – 1-1/8"** (8 – 29 mm) tubing
- Replacement cutters: **739192** copper, **739194** stainless steel



Ratchet mechanism rotates head 360° inside handle, allowing pipe cutting in confined spaces

PIPE CUTTER

2" Iron Pipe Cutter

739111 / JPC-50

- Heavy duty drop forged steel body for demanding applications
- Ideally suited for cutting steel and iron pipes
- Can also be used on copper, brass, and aluminum tubing and thin wall conduit
- Cuts **1/8 – 2"** (3 – 50 mm) tubing
- Hardened steel cutting wheel
- Large ergonomic feed handle
- Replacement cutter: **739195**



TUBE BENDER

3-in-1 Tube Bender

739142 / JTB-90

- Bends **1/4, 5/16, and 3/8"** soft tubing
- Compact design for use in confined areas
- Aluminum construction is rust proof
- Bends tubing smoothly without kinking or crushing
- Calibrated for quick reference





H.S.S. Blades



H.S.S. Blades



DEBURRING TOOLS

6" Deburring Tool

739122 / JDT-100

- Large diameter contoured plastic handle
- High speed steel blades for cutting copper, brass, aluminum and stainless steel
- Spare blade is included and housed inside handle
- Push button blade release for fast blade changes
- Suitable for left and right hand cutting
- Overall length: 6"
- Replacement cutter: **739197**

6" Pocket Clip Deburring Tool

739125 / JDT-500

- Sleek aluminum body with pocket clip
- High speed steel blade for cutting copper, brass, aluminum and stainless steel
- Blade is easily replaceable
- Suitable for left and right hand cutting
- Overall length: 6"
- Replacement cutter: **739197**

RATCHETING PVC PIPE CUTTER

1-5/8" PVC Pipe Cutter

739116 / JPPC-42

- Ratcheting action for easy progressive cutting
- Stainless steel blade
- Unique blade profile pierces pipe and prevents crushing
- Maximum capacity: 1-5/8" (42 mm)
- Replacement blade: **739198**

For All Cutters

Replacement Blades and Cutters

PROD. NO.	Application	Fits
739191	copper, brass, aluminum, steel	739109 (JMTC-30) 739102 (JTC-30) 739104 (JTTC-32)
739192	copper, brass, aluminum, steel	739105 (JTTC-42) 739107 (JQAC-50) 739108 (JRTC-28)
739193	stainless steel	739109 (JMTC-30) 739102 (JTC-30) 739104 (JTTC-32)
739194	stainless steel	739105 (JTTC-42) 739107 (JQAC-50) 739108 (JRTC-28)
739195	copper, brass, aluminum, steel, iron	739111 (JPC-50)
739197	copper, brass, aluminum, steel, iron, stainless steel	739122 (JDT-100) 739125 (JDT-500)
739198	PVC	739116 (JPPC-42)

Flaring Tool

739132 / JFT-100

- Provides 45° flare or can be used with double flaring inserts
- Designed for use on **3/16, 1/4, 5/16, 3/8, 7/16, 1/2** and **5/8" tubing**
- Cast iron yoke
- Fully polished tubing clamp
- For soft copper, brass and aluminum tubing



Flaring Tool - Heavy Duty

739133 / JFT-200

- Provides 45° flare or can be used with double flaring inserts
- Designed for use on **3/16, 1/4, 5/16, 3/8, 7/16, 1/2** and **5/8" tubing**
- Drop forged yoke and hardened steel tubing clamp for professional applications
- Ideal for automotive, HVAC, hydraulic and other heavy duty applications
- Can be used on copper, brass, aluminum and stainless steel tubing



ISO Bubble Flaring Tool Kit

H1502

- Front wheel drive cars and light trucks, both foreign and domestic, are installing the ISO sized steel brake lines with the ISO flare. This is different from the standard double flare
- Accomplishes the ISO flare without removing the brake line from the vehicle, and has the strength to withstand the pressure necessary to flare mild steel tube (1.0 mm wall thickness) used on the front wheel drive brake line
- Yoke is made of a heat treated, alloy steel drop forging, with a special patented centre screw
- Bar assembly is hardened and will hold up under repeated use and produces a smooth, consistent flare
- Kit is complete with flaring tool, four special adapters, a chamfering tool and a combination wrench and height gauge

Kit Includes:

- | | |
|----------------------------------------|-------------------------------|
| • H1502A Adapter 4.75 mm | • H1502E Bar Assembly |
| • H1502B Adapter 6 mm | • H1502F Yoke Assembly |
| • H1502C Adapter 8 mm | • H1502G Reamer |
| • H1502D Adapter 10 mm | • H1502H Wrench |

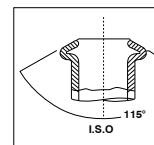

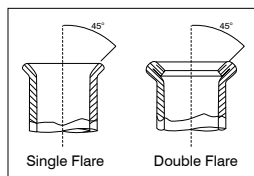

Kit includes tube cutter



FLARING TOOLS

Double Flaring Tool Kit - SAE

H1120

- Built to provide the necessary pressure to double flare steel brake tube
- Will double and single flare both copper and steel tube
- Double flare adapters provided for **3/16, 1/4, 5/16, 3/8 and 1/2"** tube
- Alloy steel swivel is heat-treated, ground, and chromed to reduce compression friction
- Yoke and bar is forged and tempered for added strength

Kit Includes:

H1120A Double Flare adapter 3/16"	H1120E Double Flare adapter 1/2"
H1120B Double Flare adapter 1/4"	H1120F Bar Assembly
H1120C Double Flare adapter 5/16"	H1120G Yoke and Bolt Assembly
H1120D Double Flare adapter 3/8"	H1120H Wingnut

Double Flaring Tool Kit - Metric

H1121

- Built to provide the necessary pressure to double flare steel brake tube
- Will double and single flare both copper and steel tube
- Double flare adapters provided for **3/16, 1/4, 5/16, 3/8 and 1/2"** tube
- Alloy steel swivel is heat-treated, ground, and chromed to reduce compression friction
- Yoke and bar is forged and tempered for added strength

Kit Includes:

H1121A Double Flare adapter 4.75 mm	H1121E Double Flare adapter 10 mm
H1121B Double Flare adapter 5 mm	H1121F Bar Assembly
H1121C Double Flare adapter 6 mm	H1121G Yoke and Bolt Assembly
H1121D Double Flare adapter 8 mm	H1120H Wingnut

Double Flaring and Cutting Tool Kit - SAE

739181 / JTFK-100

- Includes 739102 (JTC-30) Tubing Cutter, 739132 (JFT-100) Flaring Tool and Double Flaring Inserts for **3/16, 1/4, 5/16, 3/8, 7/16, 1/2 and 5/8"** tube
- Provides automotive type double flare or use without inserts for 45° flare
- Cuts up to 1-1/8" (30 mm) tube
- For soft copper, brass and aluminum tube
- Complete with blow mould storage case
- Replacement Double Flaring Dies:

3/16" - H1120A	7/16" - H1120J
1/4" - H1120B	1/2" - H1120E
5/16" - H1120C	5/8" - H1120K
3/8" - H1120D	



STRIKING TOOLS





740307



740347



740348

NAILING HAMMERS

Hickory Handle - Heavy Duty

- American hickory handles
- Forged steel heads are hardened and tempered for professional use
- Meets ANSI specifications

PROD. NO.	MOD. NO.	Head Weight	Length (Overall)	Style
740307	CW16F	16 oz	13"	Claw

Fibreglass Handle - Heavy Duty

- Highest fibreglass content for maximum strength
- Polymer jacketed to prevent splintering
- PVC grips for user comfort and safety
- Forged steel heads are hardened and tempered for professional use
- New improved bonding technology rated for use to -25°C
- Meets ANSI specifications

PROD. NO.	MOD. NO.	Head Weight	Length (Overall)	Style
740347	CF16F	16 oz	13"	Claw

Fibreglass Handle - Super Heavy Duty

- Popular "California" style framing hammer
- 1045 medium carbon steel head hardened and tempered to prevent chipping or mushrooming
- Increased head weight designed to drive larger framing nails quickly
- Extra wide milled striking face reduces missed strikes
- Straight claws make removing nails easier
- Extra thick handle at head end for added strength and resistance to overstrikes
- Grips made of high quality thermoplastic elastomers for excellent comfort and non-slip use
- Meets ANSI specifications

PROD. NO.	MOD. NO.	Head Weight	Length (Overall)	Style
740348	CFH-21	21 oz	16-1/2"	Framing



All Steel - Super Heavy Duty

- One piece steel handle is virtually immune to overstrikes
- 1055 medium carbon steel heads are hardened and tempered to prevent chipping or mushrooming
- Magnetic nail holder allows single hand use and accommodates different size nails (ripping hammer only)
- Milled face of ripping hammer minimizes slipping off the nail
- Claw hammer has smooth face for finishing work
- Grips made of high quality polypropylene and thermoplastic elastomers for excellent comfort and non-slip use
- Handle grip riveted to prevent separation
- Meets ANSI specifications

PROD. NO.	MOD. NO.	Head Weight	Length (Overall)	Style	Face
740321	CAS-16	16 oz	13"	Claw	Smooth
740331	RAS-22	22 oz	15-3/4"	Ripping	Milled



740331

Anti-Shock All Steel - Super Heavy Duty

- One piece steel handle with "tuning fork" design absorbs and dissipates vibrations through the handle rather than transmitting them to the user's forearm and elbow
- Greatly reduces fatigue and stress
- 1055 medium carbon steel heads are hardened and tempered to prevent chipping or mushrooming
- Magnetic nail holder allows single hand use and accommodates different size nails
- D-face design allows nails to be driven when close to walls or other surfaces
- Milled face of ripping hammer minimizes slipping off the nail
- Claw hammer has smooth face for finishing work
- Grips made of high quality polypropylene and thermoplastic elastomers for excellent comfort and non-slip use
- Handle grips riveted to prevent separation
- Meets ANSI specifications

PROD. NO.	MOD. NO.	Head Weight	Length (Overall)	Style	Face
740381	CAV-16	16 oz	13"	Claw	Smooth
740386	RAV-20	20 oz	13-3/4"	Ripping	Milled



740381



740158



740166



740103

BALL PEIN HAMMERS

Hickory Handle - Heavy Duty

- American hickory handles
- Forged steel heads are hardened and tempered for professional use
- Meets ANSI specifications

PROD. NO.	MOD. NO.	Head Weight	Length (Overall)
740151	BP-8H	8 oz	11-1/2"
740153	BP-16H	16 oz	14"
740155	BP-24H	24 oz	15"
740157	BP-32H	32 oz	15"
740158	BP-40H	40 oz	15-3/4"

Fibreglass Handle - Heavy Duty

- Highest fibreglass content for maximum strength
- Polymer jacketed to prevent splintering
- PVC grips for user comfort and safety
- Forged steel heads are hardened and tempered for professional use
- New improved bonding technology rated for use to -25°C
- Meets ANSI specifications

PROD. NO.	MOD. NO.	Head Weight	Length (Overall)
740161	BP-08F	8 oz	11"
740163	BP-16F	16 oz	13"
740164	BP-24F	24 oz	14-1/2"
740165	BP-32F	32 oz	15"
740166	BP-40F	40 oz	15-1/2"

Steel Handle - Super Heavy Duty

- All steel handle is virtually immune to overstrikes
- 1055 medium carbon steel heads are hardened and tempered to prevent chipping or mushrooming
- Sand blast finish with fully polished striking faces
- TPR (Thermoplastic Rubber) handle grips absorb shock and provide excellent grip
- Handle grip riveted to prevent separation
- Meets ANSI specifications

PROD. NO.	MOD. NO.	Head Weight	Length (Overall)
740103	JSPB-16	16 oz	13"
740105	JSBP-24	24 oz	13-1/2"
740107	JSBP-32	32 oz	14-1/2"





STRIKING TOOLS
INDESTRUCTIBLE HANDLE

Indestructible Handle - Super Heavy Duty

- Spring steel rods encased in vulcanized rubber provide the ultimate striking tool handle
- Handle absorbs impact and vibration, reducing user fatigue
- Will not break, bend, or split even after repeated overstrikes
- Patented locking plate makes head separation impossible
- Provides unparalleled grip in all conditions and is resistant to most industrial chemicals
- Drop forged heads heat-treated to HRC 52-56
- Developed for the mining industry, these hammers are ideal for use in applications where a failure is more than just an inconvenience
- Lifetime Warranty
- Meets ANSI specifications

PROD. NO.	MOD. NO.	Head Weight	Product Weight	Length (Overall)
740174	UBP-2414	24 oz	2.2 lb	14"
740175	UBP-3214	32 oz	2.7 lb	14"
740176	UBP-4814	48 oz	3.7 lb	14"



Deadblow - Super Heavy Duty

- One piece oven cured Polyurethane shell is much tougher than PVC, plastic, or rubber – up to 5 times the life
- Steel shot filled head directs full force of blow to the work, preventing rebound
- Precision tempered alloy steel striking face and ball pein hardened to HRC 48-54
- Beveled crown for accurate strikes
- Solid steel skeleton provides added strength and resists breaking on overstrike

PROD. NO.	MOD. NO.	Head Weight	Product Weight	Head Length	Face Diameter	Length (Overall)
740983	DBBP-16	1 lb	16 oz	4-1/4"	1-1/4"	12-3/4"
740984	DBBP-24	1-1/2 lb	24 oz	4-1/2"	1-1/2"	13"
740985	DPPB-32	2 lb	32 oz	4-7/8"	4-7/8"	16-1/4"



CLUB HAMMER

- All steel handle is virtually immune to overstrikes
- 1055 medium carbon steel head hardened and tempered to prevent chipping or mushrooming
- Sand blast finish with fully polished striking faces
- TPR handle grip absorb shock and provide excellent grip
- Handle grip riveted to prevent separation
- Meets ANSI specifications

Steel Club Hammer - Super Heavy Duty

PROD. NO.	MOD. NO.	Head Weight	Length (Overall)
740191	JSCH-25	2-1/2 lb	10-3/4"



740175



740983



740191



STRIKING TOOLS

INDESTRUCTIBLE HANDLE



STEEL LOCKING PLATE

Makes head separation impossible

HIGH VISIBILITY HEAD

Adds instant identification on any job site

VULCANIZED RUBBER GRIP

Absorbs impact and vibration, reducing user fatigue; made from special grade ozone resistant rubber for use in tough environments

DROP FORGED HEAD

With striking ends induction heat treated to HRC 52-56

SPRING STEEL BARS

9/32" (7.1 mm) diameter spring steel bars resist overstrike without breaking

TEXTURED NON-SLIP GRIP

STEEL REINFORCED LANYARD HOLE



INDESTRUCTIBLE HANDLE HAMMERS



- Spring steel rods encased in vulcanized rubber provide the ultimate striking tool handle
- Handle absorbs impact and vibration, reducing user fatigue
- Will not break, bend, or split even after repeated overstrikes
- Patented locking plate makes head separation impossible
- Provides unparalleled grip in all conditions and is resistant to most industrial chemicals
- Drop forged heads heat-treated to HRC 52-56
- Lifetime Warranty
- Meets ANSI specifications

Steel Head

- Developed for the mining industry, these hammers are ideal for use in applications where a failure is more than just an inconvenience

PROD. NO.	MOD. NO.	Head Weight	Product Weight	Length (Overall)	Type
740174	UBP-2414	24 oz	2.2 lb	14"	Ball Pein
740175	UBP-3214	32 oz	2.7 lb	14"	Ball Pein
740176	UBP-4814	48 oz	3.7 lb	14"	Ball Pein
740178	UCP-216	2 lb	4.7 lb	16"	Cross Pein
740179	UCP-316	3 lb	5.7 lb	16"	Cross Pein
740580	USH-250	2.5 lb	3.85 lb	12"	Club
740581	USH-412	4 lb	5.50 lb	12"	Sledge
740582	USH-416	4 lb	5.8 lb	16"	Sledge
740593	USH-616	6 lb	8.7 lb	16"	Sledge
740583	USH-624	6 lb	9.1 lb	24"	Sledge
740584	USH-630	6 lb	10.0 lb	30"	Sledge
740585	USH-824	8 lb	11.1 lb	24"	Sledge
740586	USH-830	8 lb	12.0 lb	30"	Sledge
740596	USH-836	8 lb	13.0 lb	36"	Sledge
740587	USH-1030	10 lb	14.5 lb	30"	Sledge
740588	USH-1230	12 lb	16.5 lb	30"	Sledge
740598	USH-1236	12 lb	17.5 lb	36"	Sledge
740589	USH-1430	14 lb	18.5 lb	30"	Sledge



Copper Head

- Heads drop forged from 99.9% pure copper for spark free use in explosive environments
- Softer copper heads will not mar struck objects
- Ideal for coal mining, oil and gas work and other potentially flammable or explosive applications

PROD. NO.	MOD. NO.	Head Weight	Product Weight	Length (Overall)	Type
740560	USH-250C	2-1/2 lb	3.75 lb	10-3/4"	Club
740565	USH-824C	8 lb	11.1 lb	24"	Sledge
740569	USH-1430C	14 lb	18.5 lb	30"	Sledge

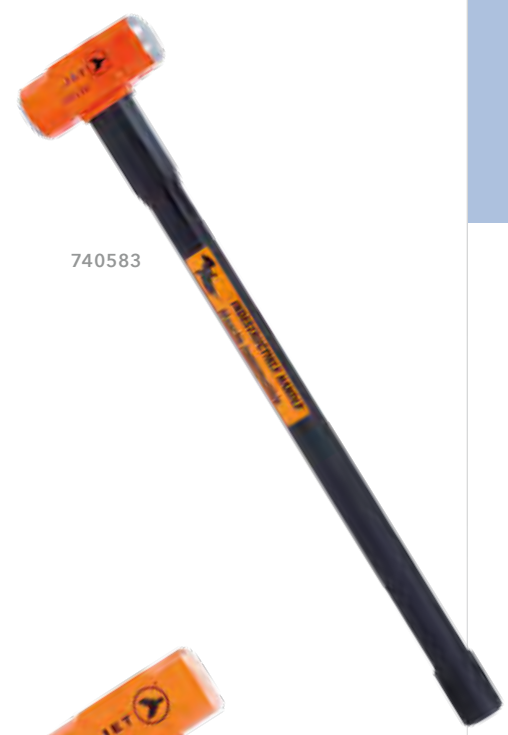



740522



740532



Smooth transition point
between fiberglass and PVC
handle for maximum comfort



740952

SLEDGE HAMMERS

Hickory Handle - Heavy Duty

- American hickory handles
- Forged steel heads are hardened and tempered for professional use
- Meets ANSI specifications

PROD. NO.	MOD. NO.	Product Weight	Length (Overall)
740522	SH-4H	4 lb	16"
740523	SH-6H	6 lb	32"
740524	SH-8H	8 lb	32"
740525	SH-10H	10 lb	32"
740526	SH-12H	12 lb	32"
740528	SH-16H	16 lb	36"

Fiberglass Handle - Heavy Duty

- Highest fiberglass content for maximum strength
- Polymer jacketed to prevent splintering
- PVC grips for user comfort and safety
- Forged steel heads are hardened and tempered for professional use
- New improved bonding technology rated for use to -25°C
- Meets ANSI specifications

PROD. NO.	MOD. NO.	Product Weight	Length (Overall)
740532	SH-4F	4 lb	16"
740533	SH-6F	6 lb	30"
740534	SH-8F	8 lb	30"
740535	SH-10F	10 lb	36"
740536	SH-12F	12 lb	36"
740538	SH-16F	16 lb	36"

DRILLING HAMMERS

Fiberglass Handle - Heavy Duty

- Highest fiberglass content for maximum strength
- Polymer jacketed to prevent splintering
- PVC grips for user comfort and safety
- Forged steel heads are hardened and tempered for professional use
- New improved bonding technology rated for use to -25°C
- Meets ANSI specifications

PROD. NO.	MOD. NO.	Head Weight	Length (Overall)
740952	DH-48F	3 lb	10-1/2"
740953	DH-64F	4 lb	10-1/2"

RUBBER MALLET



Wooden Handle

PROD. NO.	MOD. NO.	Product Weight	Length (Overall)
740403	RM-16	1 lb	13-1/4"
740407	RM-32	2 lb	13-1/2"



740912

WELDING HAMMER

Chipping Hammer

740901/ FH-1

- Quickly removes welding flux



740901

AXES AND MAULS

Fibreglass Handle - Heavy Duty

- Highest fibreglass content for maximum strength
- Polymer jacketed to prevent splintering
- PVC grips for user comfort and safety
- Forged steel heads are hardened and tempered for professional use
- New improved bonding technology rated for use to -25°C

PROD. NO.	MOD. NO.	Head Weight	Length (Overall)	Type
741107	JH-150F	1-1/2 lb	16"	Hatchet
741121	JA-250F	2-1/2 lb	34"	Axe
741123	JA-350F	3-1/2 lb	34"	Axe
741141	SM-6F	6 lb	34"	Maul
741142	SM-8F	8 lb	34"	Maul



741107

741141

741121

WARNING: always wear safety goggles



740912



740926



740977

5X POLYURETHANE SHELL
LIFE OF PVC

SOFT FACE DEAD BLOW HAMMERS

PVC Shell

- Single piece body made out of PVC, filled with steel shot
- Orange colour for high visibility

PROD. NO.	MOD. NO.	Head Weight	Length (Handle)
740912	DB-100	1 lb	11-1/2"
740913	DB-150	1-1/2 lb	12-1/2"
740914	DB-200	2 lb	13-1/2"
740915	DB-300	3 lb	16"

Polyurethane / Fibreglass - Heavy Duty

- Polyurethane is much tougher and longer lasting than PVC – up to 5 times the life
- Steel shot filled head directs full force of blow to the work preventing rebound
- Soft face will not mar work
- Fibreglass handle with Polyurethane covered striking head
- TPR handle grip for superior control and user comfort
- Temperature range of -20°C to 90°C

PROD. NO.	MOD. NO.	Head Weight	Length (Overall)
740926	DB-400HD	4 lb	12"
740927	DB-600HD	6 lb	32"
740928	DB-800HD	8 lb	32"

Polyurethane Shell - Super Heavy Duty

- One piece oven cured polyurethane shell is much tougher than PVC, plastic, or rubber – up to 5 times the life
- Superior resistance to cuts, splits, abrasions and many chemicals
- One piece seamless shell allows use in non-sparking environments
- Steel shot filled head directs full force of blow to the work, preventing rebound
- Soft face will not mar surfaces
- 6 lb and larger hammers feature flat head to allow hammer to stand upright
- Hardness Shore A 90 ±2

PROD. NO.	MOD. NO.	Head Weight	Head Length	Face Diameter	Length (Overall)
740971	DBHD-16	1 lb	3-1/2"	1-15/32"	11"
740972	DBHD-24	1-1/2 lb	4"	1-3/4"	12"
740974	DBHD-36	2-1/4 lb	4-1/2"	2-3/16"	13-1/2"
740975	DBHD-48	3 lb	4-13/16"	2-3/8"	16-3/4"
740977	DBHD-96	6 lb	7-3/32"	2-3/4"	20"
740978	DBHD-168	10 lb	7-3/32"	2-3/4"	30"
740979	DBHD-190	12 lb	8"	3-5/32"	36-1/2"



Replaceable Tip Dead Blow - Heavy Duty

- Steel shot filled head directs full force of blow to the work preventing rebound
- Soft face will not mar work
- Welded steel construction
- Hard and soft plastic faces available separately
- TPR handle grip for superior control and user comfort

PROD. NO.	MOD. NO.	Head Weight	Handle Length	Face Diameter
740932	SFH-125	20 oz	10-1/4"	1-3/8"
740933	SFH-175	29 oz	10-1/4"	1-1/2"
740934	SFH-225	38 oz	10-1/4"	1-3/4"

Replaceable Tips - Dead Blow

PROD. NO.	MOD. NO.	Description	Face Diameter
740994	RTMW-35	Medium Tip for 740932	1-3/8"
740995	RTMW-40	Medium Tip for 740933	1-1/2"
740996	RTMW-45	Medium Tip for 740934	1-3/4"
740997	RTSB-35	Soft Tip for 740932	1-3/8"
740998	RTSB-40	Soft Tip for 740933	1-1/2"
740999	RTSB-45	Soft Tip for 740934	1-3/4"



740933



PUNCH AND CHISEL - SETS

- Made of the highest grade carbon steel, accurately hardened and tempered preventing splintering and extending life
- Powder coated shank protects against rust
- Edges accurately tempered to stay sharp
- Extra-thick hexagonal shanks minimize roll away
- Working ends accurately ground and hardened to HRC 52-58 for maximum service
- Striking end hardened to HRC-42 maximum – won't chip or mushroom
- Meets Canadian Government Specifications CDA39GP-43a

WARNING: Always use punches and chisels on materials softer than the hardness of the punch itself



6 PC Pin Punch Set

775509 / PP-6S

- Pin Punch: 3/32, 1/8, 5/32, 3/16, 1/4, 5/16"
- Terylene Pouch



6 PC Roll Pin Punch Set

775526 / RPP-6S

- Roll Pin Punch: 3/32, 1/8, 5/32, 3/16, 1/4, 5/16"
- Terylene Pouch



6 PC Cold Chisel Set

775531 / CC-6S

- Cold Chisel: 1/4, 5/16, 3/8, 1/2, 5/8, 3/4"
- Terylene Pouch



WARNING: Always wear safety goggles

8 PC Punch and Chisel Set

775507 / PC8-1S

- Cold Chisel: **1/2, 5/8, 3/4"**
- Centre Punch: **5/32"**
- Solid Punch: **3/16"**
- Pin Punch: **1/8, 3/16, 1/4"**
- **Terylene Pouch**



14 PC Punch and Chisel Set

775511 / PC-14S

- Cold Chisel: **3/8, 1/2, 5/8, 3/4, 7/8"**
- Centre Punch: **5/32, 1/4"**
- Solid Punch: **1/8, 5/16"**
- Drift Punch: **1/8, 5/32"**
- Pin Punch: **1/16, 1/8, 3/16"**
- **Terylene Pouch**



16 PC Punch and Chisel Set

775508 / PC16-1S

- Cold Chisel: **5/16, 1/2, 5/8, 3/4, 7/8"**
- Centre Punch: **1/8, 5/32, 1/4"**
- Solid Punch: **1/8, 3/16, 1/4"**
- Drift Punch: **3/16, 1/4"**
- Pin Punch: **1/8, 3/16, 1/4"**
- **Terylene Pouch**



24 PC Punch and Chisel Set

775513 / PC24S

- Cold Chisel: **1/4, 5/16, 3/8, 1/2, 5/8, 3/4, 7/8"**
- Centre Punch: **5/64, 5/32, 1/4", ACP-2 Auto**
- Solid Punch: **1/16, 1/8, 5/32, 3/16, 1/4, 5/16"**
- Pin Punch: **1/16, 3/32, 1/8, 5/32, 3/16, 1/4, 5/16"**
- **Terylene Pouch**



WARNING: Always wear safety goggles



PUNCH AND CHISEL - OPEN STOCK

- Made of the highest grade carbon steel, accurately hardened and tempered preventing splintering and extending life
- Powder coated shank protects against rust
- Edges accurately tempered to stay sharp
- Extra-thick Hexagonal shanks minimize roll away
- Working ends accurately ground and hardened to HRC 52-58 for maximum service
- Striking end hardened to HRC-42 maximum – won't chip or mushroom
- Meets Canadian Government Specifications CDA39GP-43a

WARNING: Always use punches and chisels on materials softer than the hardness of the punch itself

Pin Punches

- Ideal for driving out and removing already loosened pins and keys after initial movement by a solid punch

PROD. NO.	MOD. NO.	Point	Shank	Length
775400	PP232	1/16"	1/4"	4"
775401	PP332	3/32"	1/4"	4-1/4"
775402	PP432	1/8"	5/16"	4-3/4"
775403	PP532	5/32"	5/16"	5"
775404	PP632	3/16"	5/16"	5-1/4"
775405	PP832	1/4"	3/8"	5-3/4"
775406	PP1032	5/16"	7/16"	6"

Roll Pin Punches

- Specifically designed for removing roll pins and spring pins
- Ball end keeps punch centered and allows maximum contact between pin and punch shoulder

PROD. NO.	MOD. NO.	Point	Shank	Length
775452	RPP332	3/32"	1/4"	3-1/2"
775453	RPP432	1/8"	1/4"	3-3/4"
775454	RPP532	5/32"	5/16"	4-1/2"
775455	RPP632	3/16"	5/16"	4-1/2"
775456	RPP832	1/4"	3/8"	5-1/2"
775457	RPP1032	5/16"	3/8"	6"



WARNING: Always wear safety goggles

Solid (Starting) Punches

- Solid (or starting) punches are used prior to using a pin punch and are useful for loosening frozen or tight pins and keys

PROD. NO.	MOD. NO.	Point	Shank	Length
775420	SP116	1/16"	3/8"	5"
775421	SP216	1/8"	5/16"	5"
775422	SP316	3/16"	3/8"	5"
775423	SP416	1/4"	1/2"	5"
775424	SP516	5/16"	1/2"	6"
775425	SP532	5/32"	3/8"	5"

Centre Punches

- Ideal for clearly marking metal in work layout and making indentations in a workpiece before drilling
- Working tips are centered and ground to a correct 90° included angle

PROD. NO.	MOD. NO.	Point	Shank	Length
775440	CP416	5/64"	1/4"	3-1/2"
775441	CP516	1/8"	5/16"	4-1/2"
775442	CP616	5/32"	5/16"	5-1/2"
775443	CP816	1/4"	3/8"	6"

Drift (Aligning) Punches

- Ideal for lining up holes in two or more pieces of metal and for drawing pins through various assemblies
- Often referred to as aligning punches. Pry or twist both parts into alignment and then tap gently to ensure perfect alignment

PROD. NO.	MOD. NO.	Point	Shank	Length
775410	AP532	5/32"	3/8"	9"
775411	AP216	1/8"	5/16"	8"
775412	AP316	3/16"	5/16"	10"
775413	AP416	1/4"	3/8"	10"



WARNING: always wear safety goggles



PUNCH AND CHISEL - OPEN STOCK

Cold Chisels

- Designed for cutting, shaping or removing metals softer than the chisel itself such as wrought iron, unhardened steel, aluminum, brass and copper. Can also be used on some building materials

PROD. NO.	MOD. NO.	Shank	Length	Blade Width
775430	CC430	1/4"	5"	1/4"
775431	CC516	1/4"	5"	5/16"
775437	CC616	5/16"	5-1/2"	3/8"
775432	CC816	7/16"	6"	1/2"
775433	CC1016	1/2"	6-1/2"	5/8"
775434	CC1216	5/8"	7"	3/4"
775435	CC1416	5/8"	8"	7/8"
775436	CC1616	3/4"	8-1/2"	1"

Cold Chisels - with Safety Grips

- Safety grip protects hand from overstrikes

PROD. NO.	MOD. NO.	Length	Blade Width
775461	CCG-110	10"	1"
775462	CCG-112	12"	1"

Automatic Centre Punch

- Adjustable tension controls depth of impression

PROD. NO.	MOD. NO.	Length	Diameter
775592	ACP-2	5"	1/2"



WARNING: Always wear safety goggles

- Manufactured from high quality steel and induction hardened for durability and extended life
- Stamping end hardened to 58-62 HRC – striking end hardened to 38-43 HRC to prevent splintering
- Striking ends are beveled to prevent breakage and to increase operator safety
- Sets contain: Numbers: 0 - 9 (6 and 9 are interchangeable)
- Letters: A - Z and & (ampersand)



LS Series - Letter Stamp Sets

PROD. NO.	MOD. NO.	Pieces	Characters	Size
391104	LS-030	27	Letters	3 mm (1/8")
391107	LS-050	27	Letters	5 mm (3/16")
391110	LS-060	27	Letters	6 mm (1/4")

NS Series - Number Stamp Sets

PROD. NO.	MOD. NO.	Pieces	Characters	Size
391103	NS-030	9	Numbers	3 mm (1/8")
391106	NS-050	9	Numbers	5 mm (3/16")
391109	NS-060	9	Numbers	6 mm (1/4")



WARNING: Always wear safety goggles







CONSTRUCTION TOOLS





POWER CLAW™



BARS - POWERCLAW™ SERIES

- Canada's premier super heavy duty wrecking bars are designed for the toughest jobs
- Made of tough heat treated alloy steel rather than carbon steel
- Precision ground claws are sharper and stronger than competitive products
- Electrostatic powder coated for corrosion resistance

Wrecking Bars - Super Heavy Duty

- Heavy duty extra thick profiled bar stock for maximum strength and leverage
- Extra wide face and unique curve radius allows greater leverage with less operator effort

PROD. NO.	MOD. NO.	Length	Material
779201	JPWB-14	14"	Alloy
779203	JPWB-24	24"	Alloy
779205	JPWB-36	36"	Alloy
779256	JPWB-48	48"	Alloy



779203 Extra wide face and unique curve design provides more leverage with less effort

Wrecking Bars - Notched Style - Super Heavy Duty

- Extra tight radius on curved end for increased leverage
- Nail notches on both ends for maximum versatility
- Smooth finished oval cross section shaft for maximum comfort and pulling power



PROD. NO.	MOD. NO.	Length	Material
779252	JPNB-18	18"	Alloy
779253	JPNB-24	24"	Alloy
779255	JPNB-36	36"	Alloy



779252 Nail puller notches on both ends

- Canada's premier super heavy duty wrecking bars are designed for the toughest jobs
- Made of tough heat treated alloy steel rather than carbon steel
- Precision ground claws are sharper and stronger than competitive products
- Electrostatic powder coated for corrosion resistance



Pinch Bars - Hex Shank - Super Heavy Duty

- Hex shaft bars for maximum comfort
- Pencil and chisel points for a variety of tasks

PROD. NO.	MOD. NO.	Length	Shank Size	Material
779211	JPPB-18	18"	3/4"	Alloy
779212	JPPB-24	24"	3/4"	Alloy
779213	JPPB-30	30"	3/4"	Alloy
779214	JPPB-36	36"	3/4"	Alloy
779215	JPPB-48	48"	1"	Alloy
779216	JPPB-60	60"	1"	Alloy



779211 - 779216 Hex Shank Pinch Bar

Ironworker's Pinch Bars - Round Shank - Super Heavy Duty

- Drop forged chrome alloy steel bars for professional use
- Individually magnetic particle tested to ensure complete material integrity
- Entirely heat treated, not just at the working ends, for maximum endurance
- Smooth taper assists in lining up bolt holes
- Fully chrome plated to resist corrosion

PROD. NO.	MOD. NO.	Length	Shank Size	Material
779231	JIWB-18	18"	5/8"	Chrome Alloy
779232	JIWB-24	24"	3/4"	Chrome Alloy
779233	JIWB-30	30"	7/8"	Chrome Alloy
779234	JIWB-36	36"	7/8"	Chrome Alloy



779231 - 779234 Round Shank Pinch Bar

Crow Bar - Super Heavy Duty

- Massive bar stock provides maximum strength for heavy prying and lifting jobs

PROD. NO.	MOD. NO.	Length	Weight	Material
779218	JPCB-1860	60"	18 lb	Alloy

Digging Bar - Super Heavy Duty

- Pencil point and chisel point for breaking hard packed ground
- Heavy duty bar stock provides maximum leverage for moving rocks

PROD. NO.	MOD. NO.	Length	Shank Size	Weight	Material
779258	JPDB-1772	72"	1"	17 lb	Alloy



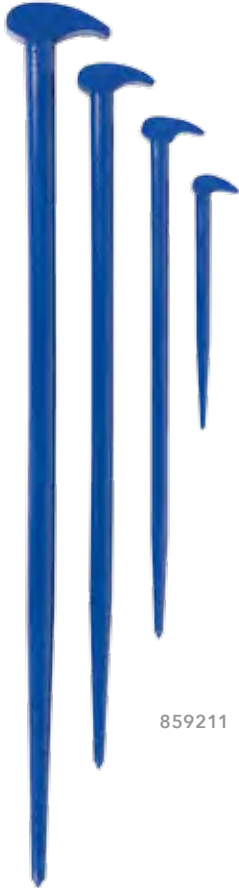

859211

Tapered point

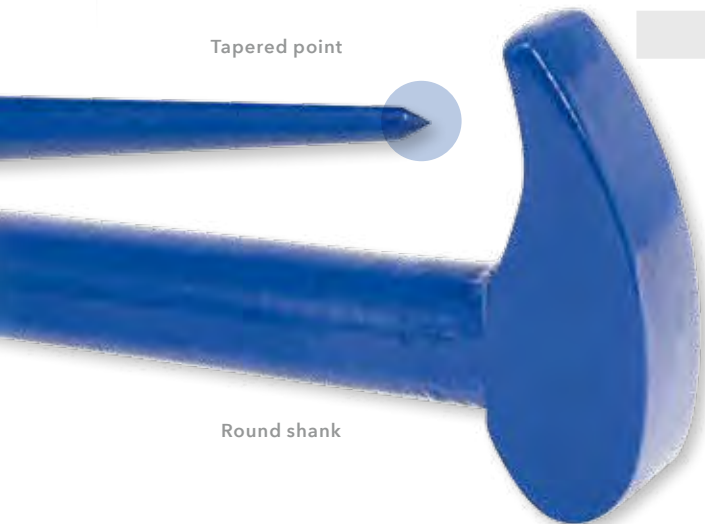

Round shank

Rounded head

BARS - POWERCLAW™ SERIES

Utility Bar

PROD. NO.	MOD. NO.	Length	Material
779112	PB-15	15"	Alloy



779112

Nail Puller

PROD. NO.	MOD. NO.	Length	Material
779113	JPNP-11	11"	Alloy



779113

4 PC Rolling Head Pry Bar Set

859211 / JROE-4S

- Rounded head acts as a fulcrum to provide extra leverage
- Tapered point and round stock ideal for aligning parts through bolt holes
- Heat treated Chrome Vanadium steel for professional use
- Magnetic particle tested to ensure complete material integrity
- Electrostatic powder coat paint protects against corrosion
- Includes: **6, 12, 16, 20"**



Rolling Head Pry Bars - Open Stock

PROD. NO.	Length	Contained in Set
859212	6"	859211
859213	12"	859211
859214	16"	859211
859215	20"	859211



Bolt Cutters - Heavy Duty

- JET bolt cutters are designed to cut soft and medium grade bolts, rods, rivets, bar and chain
- Serrated cutting edges cut with less hand force and prevent material from slipping
- **Chrome Molybdenum** steel blades
- Blades hardened to HRC 55 - 61
- Maximum hardness of material to be cut: HRC 40

PROD. NO.	MOD. NO.	Length	Capacity HRC30	Capacity HRC40	Replacement Head
731108	BC-8	8"	-	-	-
731112	BC-12	12"	3/16"	5/32"	731162
731114	BC-14	14"	1/4"	3/16"	731164
731118	BC-18	18"	5/16"	1/4"	731168
731124	BC-24	24"	3/8"	5/16"	731174
731130	BC-30	30"	1/2"	5/16"	731180
731136	BC-36	36"	5/8"	3/8"	731186
731142	BC-42	42"	3/4"	7/16"	731192



731108

731118

High Tensile Bolt Cutters - Super Heavy Duty

- Drop forged Chrome Vanadium steel blades specially hardened for use on high tensile steel bolts, rod, and chain
- Induction hardened and quenched cutting edges are suitable for cutting materials up to HRC 48
- Cutting head painted red to designate high tensile cutting ability
- Drop forged adapter and heat treated handles for maximum strength
- Powder coated for resistance to corrosion
- Meets US Federal Government Specification GGG-C-740d Type II Class 3 & 4

PROD. NO.	MOD. NO.	Length	Capacity HRC30	Capacity HRC40	Capacity HRC48	Replacement Head
731238	BCR-18	18"	5/16"	1/4"	7/32"	731278
731244	BCR-24	24"	3/8"	5/16"	9/32"	731284
731256	BCR-36	36"	5/8"	15/32"	11/32"	731296



731238



BOLT & ROD CUTTERS

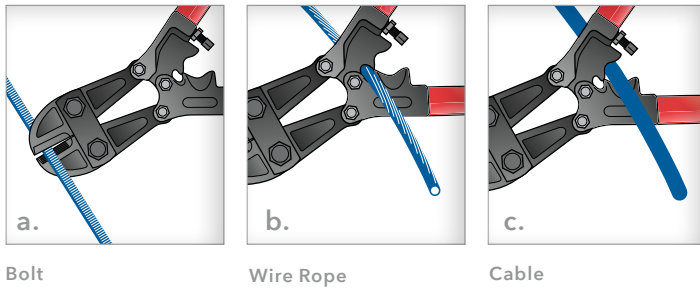
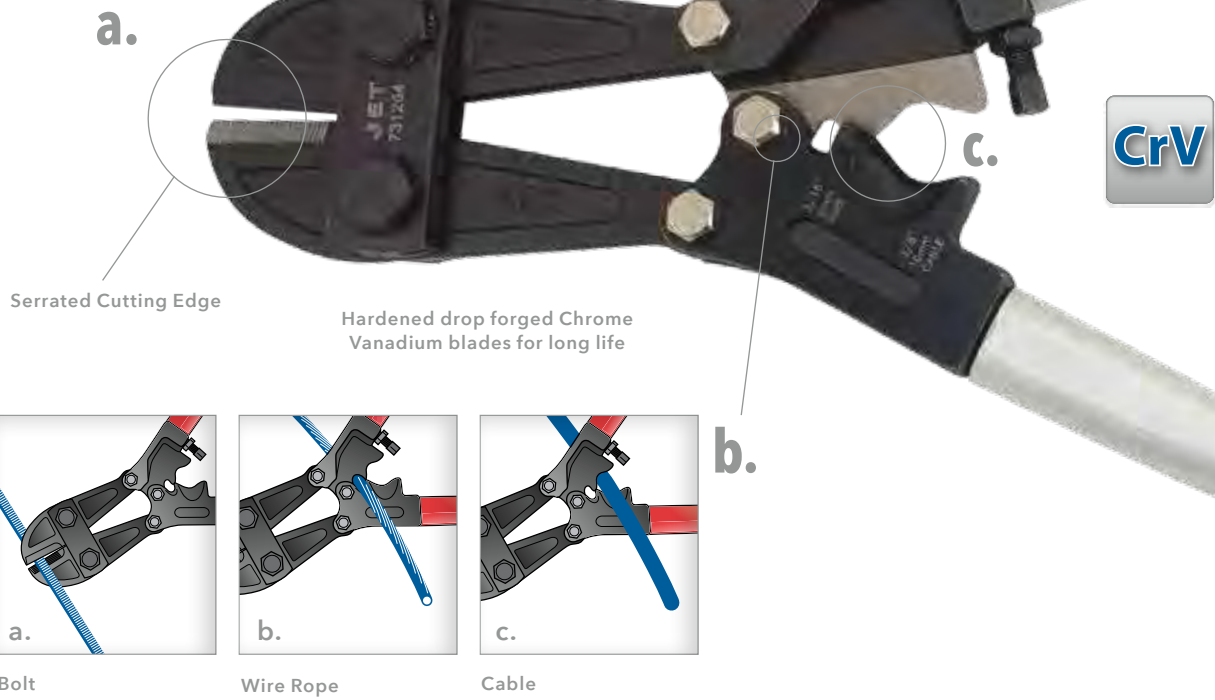

3-in-1 Bolt Cutters

- Unique design cuts bolts, rods, wire and cable
- Hardened drop forged Chrome Vanadium blades for long life
- Serrated cutting edges cut with less hand force and prevent material from slipping
- Bolt cutter blades are easily adjustable and replaceable
- Blade hardness HRC55 – 60
- Maximum material hardness HRC 42

PROD. NO.	MOD. NO.	Size	Bolt	Rebar	Wire Rope	Cable	Replacement Head
731204	BCW-18	18"	5/16"	1/4"	3/16"	3/8"	731214
731205	BCW-24	24"	13/32"	5/16"	9/32"	1/2"	731215



Rod Cutter and Bender

- A premium industrial quality rod cutter / bender for heavy duty construction applications
- Bends 5/8" rebar up to 180°

PROD. NO.	MOD. NO.	Capacity	Replacement Head
735403	RC-16	5/8"	731453



Tape Measures - Heavy Duty

- Extra wide tape provides 8' standout
- High contrast blade for easy reading
- 1/16" increments on SAE scale
- Integral rubber inserts provide maximum grip and protection
- Built-in bumper cushions recoil impact
- Easy slide lock
- Meets GS / TUV and CE standards
- Available individually carded or in display case of 12 carded tapes

PROD. NO.	MOD. NO.	Scale	Width	Overall Length
775921	JTM-416SM	SAE/Metric	1"	16' / 5m
775928	JTM-425S	SAE	1"	25'
775929	JTM-425SM	SAE/Metric	1"	25' / 7.5m



Extra Long Steel Tape Measure

775936 / JSTM-100SM

- Two sided tape features SAE measurements on one side, metric on the other
- Fast rewind provided by fold-away handle
- High contrast blade for easy reading
- 0 point inside ring
- Meets GS / TUV and CE standards
- 3/8" width
- 100' / 30m length



Open Reel Fibreglass Tape Measure

775910 / JFTM-165SM

- Two sided tape features SAE measurements on one side, Metric on the other
- Fast rewind provided by fold-away handle
- 0 point inside ring
- PVC coating prevents rot, facilitates cleaning - can be rewound when wet
- Ergonomic case with sure grip
- Tape can be removed and rewound to show either scale face up
- Meets GS / TUV and CE standards
- 1/2" width
- 165' / 50 m length



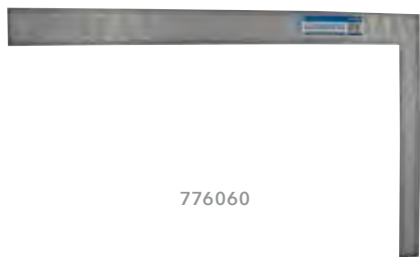

776060



MEASURING TOOLS

Framing and Layout Square

- Lacquer coated steel squares resist rust
- Clear permanently etched graduations
- 1/8" increments on all edges
- Rafter square has brace scale and rafter table

PROD. NO.	MOD. NO.	Scale	Blade	Tongue
776055	JSCS-812	SAE	1-1/2" x 12"	1" x 8"
776060	JSRS-1624	SAE	2" x 24"	1-1/2" x 16"

Rafter Angle Square

776061 / JRAS-710

- Extra thick aluminum extrusion is stronger than brittle die casts
- Will not rust
- Clear permanently etched graduations
- Measures hip, valley and common rafter angles
- Most versatile square – combines rafter and framing square, protractor, try square, mitre square and saw guide
- **7" x 7" x 10"**
- Scale SAE

Combination Square

776065 / JCS-12

- Die cast aluminum head for accuracy and durability
- Stainless steel blade with etched graduations
- SAE scale on all edges allows marking on both sides of blade
- Built in level for improved accuracy and versatility
- Convenient scratch awl
- Meets GS / TUV and CE standards
- Blade: **1" x 12"**

T-Bevel Square

776070 / JTB-8

- Use to measure and transfer angles
- SAE and Metric graduations
- Built in level for improved accuracy and versatility
- Large knurled locking wheel will not jam
- Steel blade with ABS handle
- Meets GS / TUV and CE standards
- Blade: **2" x 8"**

Aluminum Box Levels

- Box beam construction with reinforcing ribs prevents twisting and bending under normal use
- Precision milled on both surfaces for maximum accuracy
- 3 shatter-resistant acrylic block vials read horizontal, plumb and 45°
- Top read centre vial provides 300° viewing for easy readability
- Oversized hand holes for sure grip
- Shock absorbing beveled end caps
- Bright yellow finish for improved visibility
- Meets GS / TUV and CE standards

PROD. NO.	MOD. NO.	Overall Length	Vials
776001	JBL-9924B	24"	3
776002	JBL-9948B	48"	3
776004	JBL-9972B	72"	3

Top read centre vial



776001

Aluminum Box Levels - Heavy Duty

- Extra thick aluminum stock extruded into a unique profile offers the ultimate in strength and resistance to twisting
- Precision milled on both surfaces for maximum accuracy
- V-groove on bottom surface for use on pipe
- Hidden magnets in bottom surface hold level securely to metal objects
- 3 shatter-resistant mono block acrylic vials (1 horizontal, 2 plumb)
- Top read centre vial provides 300° visibility
- Double layer rubber and plastic end caps offer superior shock absorption
- Meets GS/TUV and CE standards

PROD. NO.	MOD. NO.	Overall Length	Vials
776021	JPBL-24	24"	3
776022	JPBL-48	48"	3

Top read centre vial



Magnetic V-grooved base

776021

Double layer end cap for superior shock absorption



Torpedo Level

776006 / JTL-9B

- 9" aluminum frame for improved accuracy and durability
- Top read centre vial for easy readability, provides 300° viewing
- 3 vials read horizontal, plumb and 45°
- White frame around vials for improved readability
- Magnetic strip holds level securely to metal objects
- Meets GS / TUV and CE standards



779161

Chalk Line Set

779161 / JACL-100S

- Aluminum case for maximum durability
- Holds 100' of line
- Can be used as a plumb bob
- Includes 3" line level and 4 oz. chalk



Replacement Chalk

779162 / JBPC-4

- 4 oz. fine blue layout chalk
- For use with any chalk line reel



Plumb Bob - Brass

779171 / JBPB-12

- 12 oz. solid machined brass
- Hardened steel replaceable tip
- Extra tip included
- Top unscrews for easy line centering

STAPLERS AND TACKERS

- JET staplers and hammer tackers are designed for professional use
- Durable all steel or aluminum construction
- Nickel plated finish resists corrosion
- Low staple viewing window
- Handle lock allows compact storage

STAPLE GUNS

Standard Duty

849403 / JSG-103

- Exclusive swing-away channel for easy clearing of jammed staples
- Perfect for light to medium duty applications
- Uses **1/4" - 5/16" Standard Duty JET staples** or equivalent

Heavy Duty

849411 / JSG-101HD

- Comfortable PVC hand grip
- For upholstery, fencing, carpeting, ceiling tile, insulation and many other uses
- Uses **1/4" - 9/16" Heavy Duty JET staples** or equivalent

Staple / Nail Gun - Heavy Duty

849412 / JSG-102HD

- Die cast aluminum alloy housing will not rust
- Ergonomic design allows application of maximum pressure without fatigue
- 2 position adjustment lever provides the ideal power for use on soft or hard materials
- Bi-material hand grip for increased comfort
- Bottom loading design for fast refills and easy clearing of jammed staples
- For upholstery, fencing, carpeting, ceiling tile, insulation and many other uses
- Unique lock allows compact storage
- Uses **1/4" - 9/16" Heavy Duty JET staples** or equivalents and **18 gauge brad nails**
- Low staple viewing window



849403



849411



849416

849407



STAPLERS AND TACKERS

Hammer Tackers

Standard Duty

849409 / JHT-102

- Perfect for light to medium applications
- Large PVC grip for maximum comfort
- Uses **1/4" - 5/16" Standard Duty JET staples** or equivalent

Heavy Duty

849416 / JHT-101HD

- 32 oz total weight provides maximum hitting power
- Ideal for carpet and underlay, roofing felt, plastic sheeting etc.
- Comfortable rubber handle for maximum grip
- Rear loading magazine
- Uses **1/4" - 3/8" Heavy Duty JET staples** or equivalent

Staples

- Designed for use with JET staplers or any brand compatible with Arrow® T-50 or JT-21 staplers
- 1,000 staples per box
- Available in various lengths from 1/4" to 9/16"
- Available for standard duty and heavy duty applications

PROD. NO.	MOD. NO.	Description	Use With Models
849481	JS-1006	1/4" SD Staples	849403 (JSG-103) 849407 (JHT-102)
849482	JS-1008	5/16" SD Staples	849403 (JSG-103)
849491	JS-1006HD	1/4" HD Staples	849411 (JSG-101HD) 849412 (JSG-102HD) 849416 (JHT101HD)
849492	JS-1008HD	5/16" HD Staples	849411 (JSG-101HD) 849412 (JSG-102HD) 849416 (JHT101HD)
849493	JS-1010HD	3/8" HD Staples	849411 (JSG-101HD) 849412 (JSG-102HD) 849416 (JHT101HD)
849494	JS-1012HD	1/2" HD Staples	849416 (JSG-101HD) 849412 (JSG-102HD)
849495	JS-1014HD	9/16" HD Staples	849411 (JSG-101HD) 849412 (JSG-102HD)

- Cast aluminum frames combine high strength with light weight
- TPR grip on handle for comfort and secure grip
- Blade can be angle mounted for special applications
- Powder coated for added resistance to corrosion

12" Ergonomic Frame

775306 / 525A

- Heavy ergonomic frame accepts 12" blades
- Front frame with contoured grip for better control
- Convenient in handle blade storage



12" Blades

12" Oval Tube Style - Heavy Duty

775307 / JHS-5012

- Oval tube provides greater strength than square tube saws
- Extra thick cast aluminum frame components for heavy duty professional applications
- Easy to use wing nut provides up to 3,000 PSI tension on blade
- Blade can be mounted at 45° for special applications
- Unique blade storage compartment holds up to 6 spare blades



12" Blades

12" Aluminum I-Beam Style

775308 / JHS-3012

- One piece cast aluminum I-beam frame for rigidity
- Easy to use wing nut provides up to 2,500 PSI tension on blade
- Blade can be mounted at 45° for special applications



12" Blades

JET-KUT® Bi-Metal Hacksaw Blades

- Bi-metal construction with carbon steel core and high speed steel teeth thermally treated under high vacuum
- Flexible and shatterproof safety blades
- An excellent performing, long lasting blade for a wide range of applications

PROD. NO.	Size (inches) L x W x T	Teeth TPI	Pkg Qty
566231	12 x 1/2 x 0.25	18	10 / 100
566232	12 x 1/2 x 0.25	24	10 / 100
566233	12 x 1/2 x 0.25	32	10 / 100



566231



566232



566233





SHOP EQUIPMENT





C-CLAMPS



Mini Size Clamps



CCJ - Series Junior C-Clamps

- Drop forged steel frames for maximum strength in a minimum size
- Powder coated frames and zinc plated screws resist corrosion
- Narrow frames allow use in the most confined spaces
- Swivel pads adopt correct angle for maximum pressure

PROD. NO.	MOD. NO.	Maximum Opening	Throat Depth	Clamping Pressure (lb)
390151	CCJ-100	1"	1"	500
390153	CCJ-150	1-1/2"	1-1/2"	850
390155	CCJ-200	2"	1-1/4"	875
390157	CCJ-300	3"	1-3/8"	850

CSG Series - Cast Iron Clamps

- SG Cast Iron clamps with Spheroidal Graphite structure produces 60,000 PSI tensile strength - twice the tensile strength of ductile iron clamps!
- Guaranteed unbreakable during normal use
- Reinforced frame corners
- Cross handle designed to bend before the frame can be over stressed
- Acme threaded screw for smooth operation and even clamping pressure
- Black oxide coated screw and handle resists weld and corrosion

PROD. NO.	MOD. NO.	Maximum Opening	Throat Depth	Clamping Pressure (lb)
390142	CSG-4	4"	2-11/32"	2,640
390143	CSG-6	6"	3"	2,860
390144	CSG-8	8"	3-1/8"	2,640
390145	CSG-10	10"	3-1/2"	2,530
390146	CSG-12	12"	4"	2,530

CC Series - Regular Throat Clamps - Heavy Duty

- Industrial quality drop forged heat treated steel C-clamps
- Heavy duty swivel pads are secured by a special retaining clip that is superior to crimped pads
- Acme threaded screw for smooth operation and even clamping pressure
- Black oxide screw resists welding spatter

PROD. NO.	MOD. NO.	Maximum Opening	Throat Depth	Clamping Pressure (lb)
390102	CC-2	2-3/16"	1"	3,300
390103	CC-3	2-5/8"	1-1/2"	4,350
390104	CC-4	4"	1-3/4"	5,300
390105	CC-5	4-5/8"	2-1/16"	5,900
390106	CC-6	6-1/4"	2-1/2"	7,650
390108	CC-8	7-1/2"	3-1/4"	8,850
390110	CC-10	9-1/2"	4-1/4"	9,000
390112	CC-12	11-9/16"	4-1/2"	13,000



390102



390106

CC-D Series - Deep Throat Clamps - Heavy Duty

- Industrial quality drop forged heat treated steel C-clamps
- Extra deep throat depths for maximum versatility
- Smooth acting Acme threaded screws for maximum clamping force
- Black oxide coated screw and pads minimize splatter adhesion
- Special pad retaining clips are superior to crimped pads
- Unique clamp profile provides incredible strength yet is lighter than most competing models
- Ideal for all welding and clamping applications

PROD. NO.	MOD. NO.	Maximum Opening	Throat Depth	Clamping Pressure (lb)
390122	CC-2D	2-1/8"	2-1/4"	3,500
390123	CC-3D	3"	2-1/2"	3,500
390124	CC-4D	4-1/4"	3-1/4"	6,200
390125	CC-6D	6-1/16"	4-1/8"	6,600
390126	CC-8D	8-1/4"	5"	6,900
390127	CC-10D	10-1/8"	6"	8,000
390129	CC-12D	12-1/4"	6-5/16"	9,300

Extra Deep Throats



390124



390125



L-CLAMPS

- Tempered drop forged sliding arm reduces clamping set up time – ideal for high volume production work
- Nickel-chrome plated rails are heat formed from cold drawn profiled steel
- Extra deep throats for maximum versatility
- High carbon Acme threaded spindle is spatter resistant
- Rails, sliding arms, and spindles 100% heat treated
- Replaceable spindle and pads
- Specialized pads available for JLHD and JLSJ Series



390202



390224

JLRD Series - L-Clamps

- Generous clamping pressure and throat depth for a wider range of applications
- Standard swivel pads

PROD. NO.	MOD. NO.	Opening	Throat Depth	Rail Size	Clamping Pressure (lb)
390202	JLRD-6	6"	4-3/4"	1-3/16 x 9/16"	2,640
390204	JLRD-8	8"	4-3/4"	1-3/16 x 9/16"	2,640
390206	JLRD-10	10"	4-3/4"	1-3/16 x 9/16"	2,640
390208	JLRD-12	12"	5-1/2"	1-3/16 x 9/16"	2,640
390210	JLRD-16	16"	4-3/4"	1-3/16 x 9/16"	2,640
390212	JLRD-20	20"	4-3/4"	1-3/16 x 9/16"	2,640

JLHD Series Deep Throat Clamps - Heavy Duty

- Increased throat depth and heavy duty cold forged swivel pads
- Pads tilt to 35°
- Serrated and V-Pads available for special applications

PROD. NO.	MOD. NO.	Opening	Throat Depth	Rail Size	Clamping Pressure (lb)
390224	JLHD-8	8"	5-1/2"	1-3/16 x 9/16"	2,640
390226	JLHD-10	10"	5-1/2"	1-3/16 x 9/16"	2,640
390228	JLHD-12	12"	5-1/2"	1-3/16 x 9/16"	2,640
390230	JLHD-16	16"	5-1/2"	1-3/16 x 9/16"	2,640
390232	JLHD-20	20"	5-1/2"	1-3/16 x 9/16"	2,640
390233	JLHD-24	24"	5-1/2"	1-3/16" x 9/16"	2,640

JLSD Series - Deep Throat Clamps - Super Heavy Duty

- The ultimate in depth and strength
- 45% greater clamping pressure than our heavy duty clamps
- Serrated and V-pads available for special applications

PROD. NO.	MOD. NO.	Opening	Throat Depth	Rail Size	Clamping Pressure (lb)
390248	JLSD-12	12"	6-3/4"	1-9/16 x 3/4"	4,840
390250	JLSD-16	16"	6-3/4"	1-9/16 x 3/4"	4,840
390252	JLSD-20	20"	6-3/4"	1-9/16 x 3/4"	4,840
390254	JLSD-24	24"	6-3/4"	1-9/16 x 3/4"	4,840



L-Clamp Accessories

- Replacement parts for L-Clamps

PROD. NO.	Description	PROD. NO.	Description
390292	Plain Pad for JLHD/JLSD L-Clamp	390296	Screw & Handle for JLHD L-Clamp
390293	Serrated Pad for JLHD/JLSD L-Clamp	390297	Screw & Handle for JLSD L-Clamp
390294	V Pad for JLHD/JLSD L-Clamp	390298	Nut for JLHD/JLSD L-Clamp
390295	Screw & Handle for JLRD L-Clamp	390299	Ball Joint for JLHD/JLSD L-Clamp



PIPE CLAMP

JPC Series - Pipe - Heavy Duty

390482 / JPC-7500

- Uses standard 3/4" threaded pipe (not included)
- Flat base allows clamp to stand on work bench for stable support
- Clamp height allows full turn of handle without contacting work surface
- Non-marring pads protect work from damage

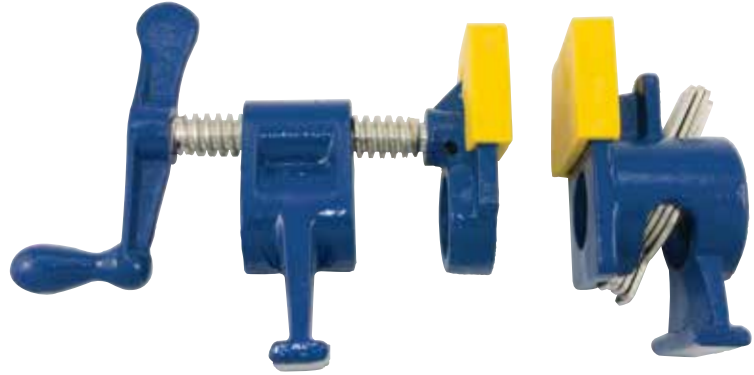

Flat base allows stable support on work bench and allows handle to turn without contacting surface

SPRING HAND CLAMPS

JSSC Series - Steel / Woodworking

- Nickel plated to resist corrosion
- Vinyl grips for sure hold
- Use anywhere moderate clamping pressure is required

PROD. NO.	MOD. NO.	Nominal Opening	Overall Length
390457	JSSC-4	1"	4"
390458	JSSC-6	2"	6"

VICES

Precision machined
hardened steel jaws

JSV Series - Swivel Vise - Heavy Duty

- Class 30 iron, 30,000 lb tensile strength castings
- Precision machined hardened steel jaws (replaceable)
- Built-in pipe jaws
- Machine ground anvil surface
- 360° swivel base with dual lock down handles
- Shot blast finish powder coat paint for protection from corrosion

PROD. NO.	MOD. NO.	Jaw Width	Maximum Opening	Throat Depth	Pipe Capacity	Product Weight
320151	JSV-4HD	4"	4"	2-3/4"	1-1/2"	23 lb (10 kg)
320152	JSV-5HD	5"	5"	3-3/4"	2"	31 lb (14 kg)
320153	JSV-6HD	6"	6"	4"	2-1/2"	45 lb (20 kg)
320154	JSV-8HD	8"	8"	4"	3-1/2"	70 lb (31.5 kg)



320154



VICES



320312



320316

SG Iron Series - Super Heavy Duty

- Strongest cast vise on the market
- Massive casting made of superior quality 80,000 PSI tensile strength SG iron for maximum strength and impact resistance
- Spheroidal graphite (SG) iron forms a much stronger molecular structure than regular cast iron
- Up to 30% higher tensile strength than competing ductile iron vises
- Precision machined hardened steel jaws
- Polished ACME threaded screw for smooth operation and maximum strength
- Sliding beam is accurately machined on all sides for smooth operation
- Enclosed at the back to protect screw from dirt and debris
- Shot blast finish powder coat paint for protection from corrosion
- Optional 360° swivel base with dual lock down handles

PROD. NO.	MOD. NO.	Jaw Width	Maximum Opening	Throat Depth	Product Weight
320312	JVSG-4	4"	4-5/8"	2-3/4"	31 lb (14 kg)
320313	JVSG-5	5"	7-1/16"	3-11/32"	51 lb (23 kg)
320314	JVSG-6	6"	7-7/8"	3-1/2"	73 lb (33 kg)
320315	JVSG-8	8"	8-7/8"	4-3/32"	88 lb (39-1/2 kg)



Swivel Base for SG Iron Vise - Super Heavy Duty

- Swivel base converts standard JVSG vises to swivel operation for added versatility
- Powerful dual locking handles keep vise in place
- Made of the same SG ductile cast iron as the vise for maximum strength

PROD. NO.	MOD. NO.	Size	Product Weight
320316	JVSG-4	4"	6 lb (2.7 kg)
320317	JVSG-5	5"	9.9 lb (4.45 kg)
320318	JVSG-6	6"	13.8 lb (6.21 kg)
320319	JVSG-8	8"	17.4 lb (7.83 kg)



MPV Series Multi-Purpose Vise - Heavy Duty

- Class 30 iron, 30,000 lb tensile strength castings
- Precision machined heavy duty steel jaws (replaceable)
- Jaws can be locked at any angle
- Index scale allows accurate adjustment of jaw angle
- 360° swivel base with dual lock down handles

PROD. NO.	MOD. NO.	Jaw Width	Maximum Opening	Throat Depth	Pipe Capacity	Product Weight
321336	MPV-125S	5"	4-11/16"	3"	3"	46 lb (20 kg)

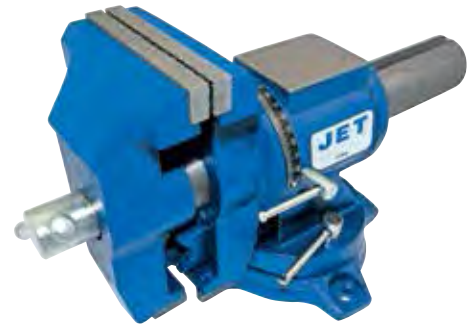

DPV Series Drill Press Vise - Heavy Duty

- Accurately ground base and slides
- Uni-grip mechanism allows powerful clamping force with minimal effort
- Eliminates need for crossbars or drop away handles
- Replaceable jaws hold round objects securely

PROD. NO.	MOD. NO.	Jaw Width	Maximum Opening	Jaw Depth
321124	DPV-4U	4"	3-1/2"	1-3/16"

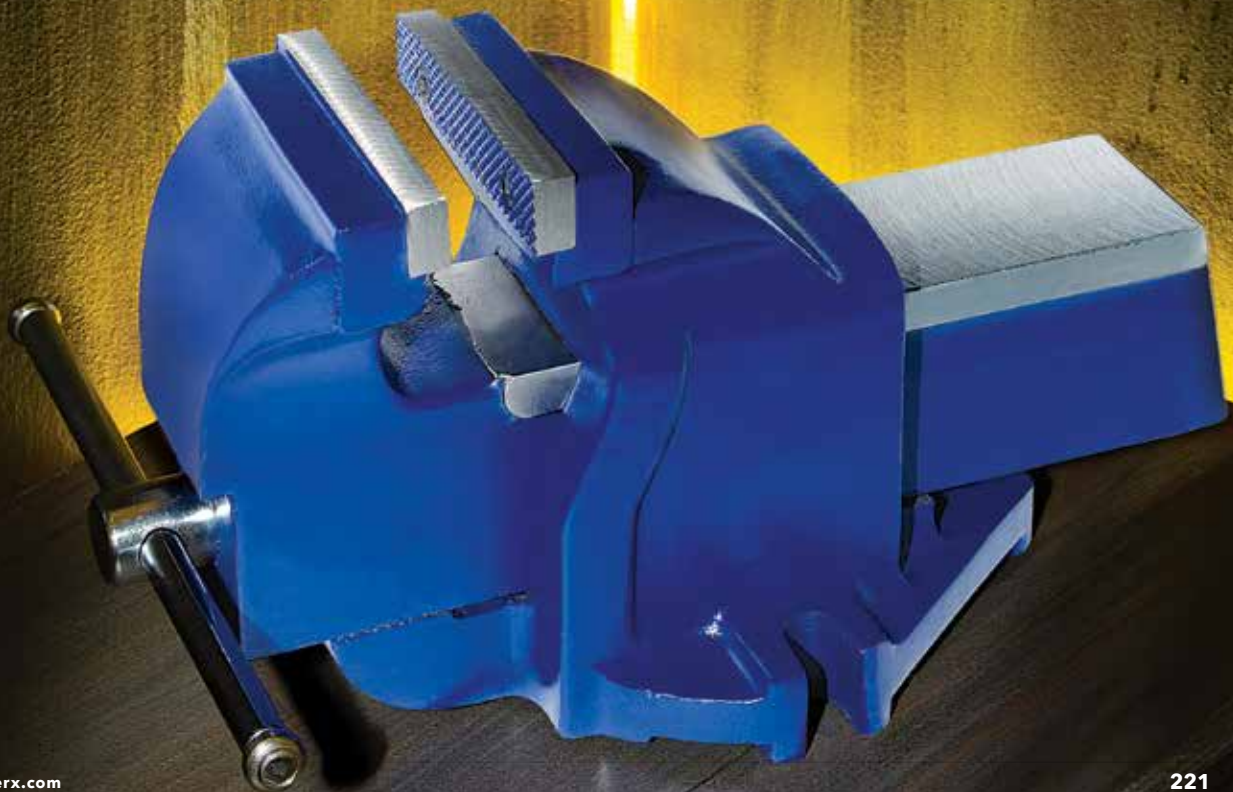



PALLET TRUCK

PT Series – Heavy Duty

- High quality 5,500 lb capacity
- High tensile steel frame and one piece "C" section forks with welded reinforcement for superior strength
- 3 position control lever automatically returns to neutral position
- Handle operates from rear and sides and returns to upright position when released
- Ergonomic handle grip for operator comfort and positive control
- Entry rollers in front of load rollers allow easy entry and exit from pallets
- Totally sealed hydraulic pump for reliable leak-free operation
- Built-in overload protection and top of stroke bypass valve prevents damage
- Slow lowering hand control valve for optimum control
- Large diameter polyurethane coated steel steer wheels and polyurethane load rollers for maximum maneuverability and smooth transport of heavy loads
- Steering column swivels 202°
- Fully adjustable push rods for fork height adjustment
- 27" x 48" forks are extra wide for maximum strength
- Grease fittings at all key points

Heavy lifting
See our Material Handling section
for similar products

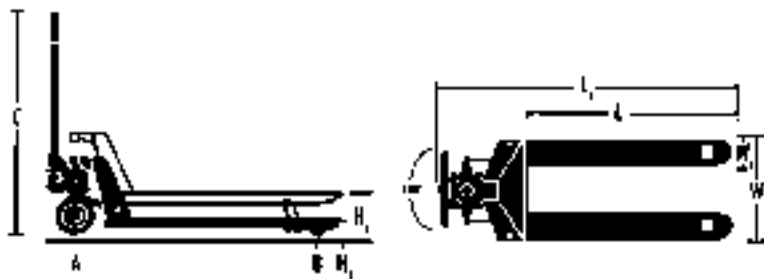

PROD. NO.	MOD. NO.	Rated Lifting Capacity (lb)	Skid Quantity	W1	W2	L1	L2	H1	H2	A	B	Product Weight (lb/kg)
190918	PT-5500	5,500	6	27"	7"	48"	61-1/2"	7-1/4"	2-31/32"	7-7/8" x 2-1/2"	2-29/32" x 3-55/64"	209 lb (95 kg)



Totally sealed H.D. hydraulic unit.



Three position control lever for operator convenience.



Heavy duty single front wheel with entry, exit roller wheel.



Fully adjustable push rods.

SCISSOR LIFT HAND CART



SLC Series – Heavy Duty

- Hydraulic table designed for lifting and lowering
- Foot pedal for easy table lifting
- Wire control for convenient operation is superior to knob control
- Large table size
- Wheel stops for positioning cart
- Polyurethane casters for smooth travel
- Industrial quality



PROD. NO.	MOD. NO.	Rated Lifting Capacity (lb)	Minimum Table Height	Maximum Table Height	Handle Height	Table Dimensions	Wheel Diameter	Foot Pedal Cycles to Max. Height
190968	SLC-1100	1,100	11-1/2"	35-3/4"	38-7/8"	33-1/2 x 19-3/4"	5"	27





PARTS WASHERS

20 Gallon - Heavy Duty

- Lid hinge equipped with fusible link for added fire safety
- 45 litre working capacity tank includes basket and work shelf
- Flexible delivery spigot
- Screened inlet protects pump from foreign material
- cUL approved pump
- For use with water-based cleaning solutions with a pH of 7-8

PROD. NO.	MOD. NO.	Motor	Tank Dimensions
355002	JPW-634	115 Volt / 60 Hz. 0.5 Amp	30" W. x 21" D. x 36" H.

40 Gallon - Heavy Duty

- Lid hinge equipped with fusible link for added fire safety
- Extra large (70-83 litre) working capacity
- Comes with ground fault interrupt plug
- cUL approved pump
- For use with water-based cleaning solutions with a pH of 7-8

PROD. NO.	MOD. NO.	Motor	Tank Dimensions
355008	JPW-40	115 Volt / 60 Hz. 0.5 Amp	43-1/4" W. x 10-5/8" D. x 20-1/2" H.

Flo-Thru Parts Brush

- Reduce parts cleaning time by 50%
- 4" long bristles suitable for use with water based (aqueous) cleaner
- Easy attachment fitting fits most parts washers

PROD. NO.	MOD. NO.	Product Dimension
355091	JPWB-6356	10" L. x 1-1/2" W.

37" Fixed Head 6 Wheel Creeper

- Creepers make repairs faster and easier
- Full length padded centre panel
- Six double post swivel casters for easy maneuverability and even distribution of weight to prevent creeper from bowing
- Creeper bed is only 3-1/2" high

PROD. NO.	MOD. NO.	Length x Width x Height	Clearance	Maximum Capacity	Wheel Size
355105	JFHC-640	37" x 18" x 3-1/2"	3-1/2"	300 lb	2-1/2"



Double post casters for maximum strength

42" Adjustable Head Creeper

- Adjustable headrest reduces stress on neck muscles
- Drop shoulder for ease of movement
- Six double post casters for easy maneuverability and even distribution of weight to prevent creeper from bowing

PROD. NO.	MOD. NO.	Length x Width x Height	Clearance	Maximum Capacity	Wheel Size
355115	JAHC-643	42" x 15" x 3-1/2"	3-1/2"	300 lb	2-1/2"



6 Wheel Mechanic's Creeper

- Unique closed cell construction provides unparalleled strength and rigidity
- Designed for unrestricted arm movement
- 6 large double post casters with ball bearings for easy maneuverability
- Dual parts trays
- Large padded head rest
- Can be hung out of the way using convenient handle
- Made of high quality chemical resistant HDPE for long life
- Easily recyclable where facilities exist



PROD. NO.	MOD. NO.	Length x Width x Height	Clearance	Maximum Capacity	Wheel Size
355130	JBMC-620	39-1/2" x 18-1/2" x 4-5/16"	7/8"	400 lb	3"





ROLLER SEATS

Mechanic's Roller Seat

- Padded seat rolls on ball bearing casters
- Reinforced vinyl over 1-3/4" thick foam
- Convenient under seat tray keeps tools and parts in easy reaching distance
- Frame is constructed of 1" steel tubing

PROD. NO.	MOD. NO.	Width x Depth x Height	Maximum Capacity	Casters (4)
355153	JMS-641	14" x 17-1/2" x 14-1/4"	300 lb (135 kg)	2-1/2"



Mechanic's Adjustable Height Roller Seat

- Air piston allows for height adjustment
- Padded seat rolls on ball bearing casters
- Convenient under seat tray keeps tools and parts in easy reaching distance

PROD. NO.	MOD. NO.	Height	Maximum Capacity	Casters (5)
355158	JMS-642	18"	300 lb (135 kg)	2-1/2"

Anti-Fatigue Mats

- Thick closed cell EVA foam pads protect workers from hard, rough surfaces
- Resists absorption of water, oil and many chemicals, is non-conductive and easy to clean
- Ultra-light weight for portability, with convenient hand hole for easy carrying and storage
- Can be used as an anti-fatigue mat, kneeling pad, under car mat, or anywhere a worker needs to be kept off the ground
- Ideal for service vehicles, roofers, installers, mechanics, shippers, production line workers, store clerks etc.
- Due to the nature of this product no warranty is offered

PROD. NO.	MOD. NO.	Product Dimension (Width x Depth x Height)
355191	JAFM-500	19-1/4" x 11-3/4" x 1-3/16"
355193	JAFM-1100	43" x 19-5/8" x 1-3/16"







METAL / WOODWORKING MACHINERY

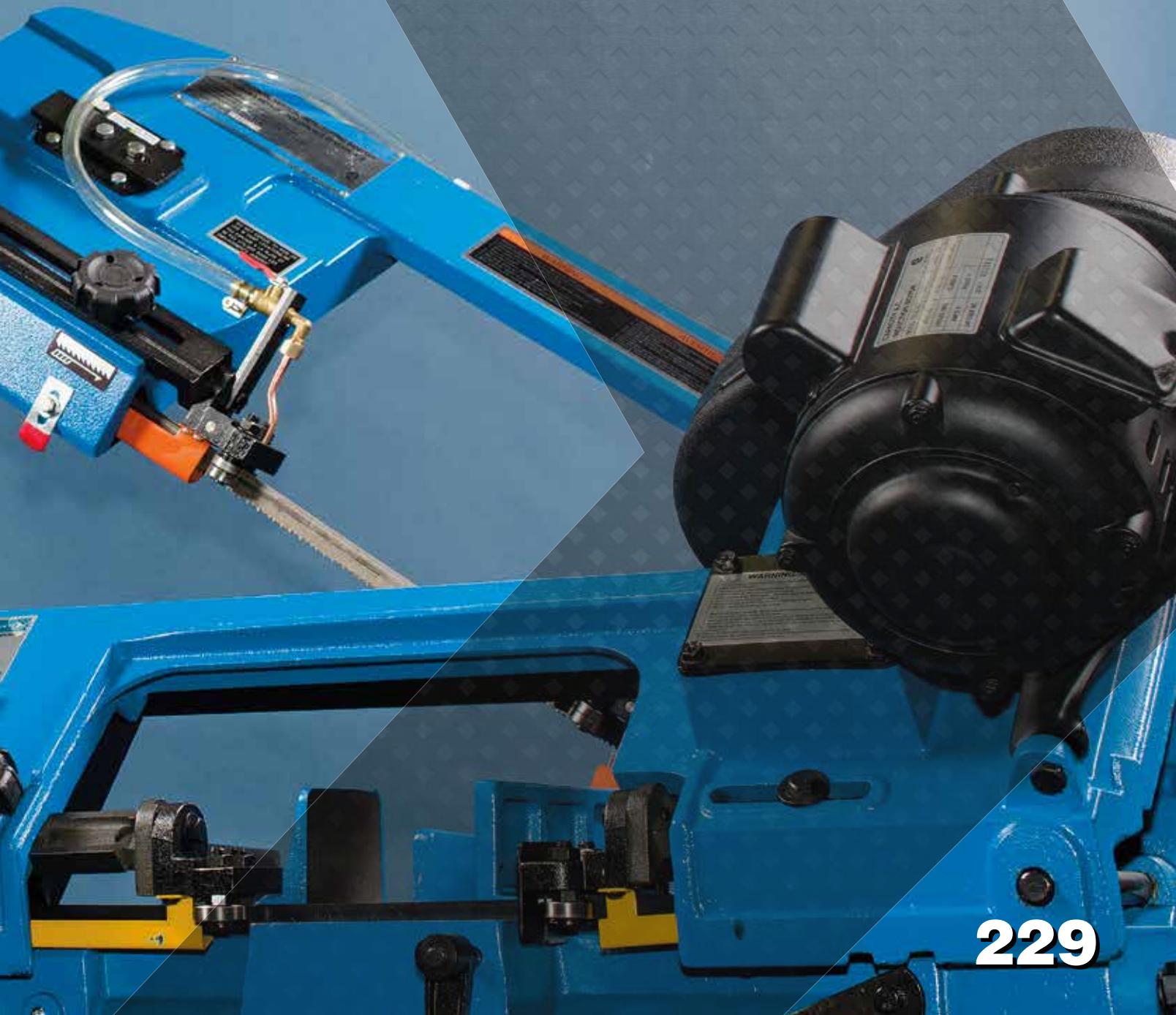

229



2 YEAR WARRANTY

BENCH GRINDERS

- Heavy duty construction for maximum service life
- CSA electrics for safety and reliability
- All ball bearing construction
- Steel wheel covers with rear dust exhaust ports
- Easy to adjust steel tool rests
- Eye shields and spark guards for operator safety
- Rubber feet on base for reduced vibration
- Includes coarse and medium grinding wheels

Heavy Duty

PROD. NO. MOD. NO.	240153 BGC-6	240154 BGC-8
Motor	1/3HP, 1Ph, 115V	1/2HP, 1Ph, 115V
Amperage	3.5, 60Hz	5, 60Hz
R.P.M.	3,450	3,600
Arbor Size	1/2"	5/8"
Wheel Size	6" x 3/4" x 1/2"	8" x 1" x 5/8"
Product Weight	26 lb	39 lb
Shipping Weight	28 lb	42 lb

OPTIONAL ACCESSORIES

See our Abrasives Section

JET High Performance Wire Brushes

PROD. NO.	MOD. NO.	Dia.	Min Face Width	Centre Hole	Maximum RPM	Wire Dia. & Type
550121	101F-2M	6"	7/8"	1/2" - 5/8" - 2"	6,000	.014" M
550123	101F-2F	6"	7/8"	1/2" - 5/8" - 2"	6,000	.007" F
550124	101F-3C	6"	1"	1/2" - 5/8" - 2"	6,000	.020" C
550125	101F-3M	6"	1"	1/2" - 5/8" - 2"	6,000	.014" M
550141	101G-2C	8"	7/8"	1/2" - 5/8" - 2"	4,500	.020" C
550142	101G-2M	8"	7/8"	1/2" - 5/8" - 2"	4,500	.014" M
550143	101G-2F	8"	7/8"	1/2" - 5/8" - 2"	4,500	.007" F

F = Fine **M** = Medium **C** = Coarse

550125

522263



General Purpose Grinding Wheels

PROD. NO.	MOD. NO.	Size	Grade	Maximum RPM
522163	A675C	6" x 3/4" x 1"	36	4,138
522164	A675M	6" x 3/4" x 1"	46	4,138
522165	A675F	6" x 3/4" x 1"	60	4,138
522173	A610C	6" x 1" x 1"	36	4,138
522174	A610M	6" x 1" x 1"	46	4,138
522175	A610F	6" x 1" x 1"	60	4,138
522176	A610EF	6" x 1" x 1"	80	4,138
522263	A875C	8" x 3/4" x 1"	36	3,600
522264	A875M	8" x 3/4" x 1"	46	3,600
522265	A875F	8" x 3/4" x 1"	60	3,600
522273	A810C	8" x 1" x 1"	36	3,600
522274	A810M	8" x 1" x 1"	46	3,600
522275	A810F	8" x 1" x 1"	60	3,600

36 Grade = **Coarse** 46 Grade = **Medium** 60 Grade = **Fine** 80 Grade = **Extra Fine**

13-1/2" 3/4 HP 12 Speed Drill Presses

- Powerful 3/4 horse power motor
- 12 speed capability allows for a broad assortment of drilling applications
- Safety on/off switch
- Fully hinged belt and pulley cover and fully adjustable motor mount permit fast changes of spindle speed
- Worktable with quick release clamp rotates and tilts to 45° right and left
- Slots in worktable permit easy clamping of the work piece
- Positive depth setting mechanism uses a threaded rod and two lock nuts for accuracy
- Built-in work lamp with separate switch (bulb not included)

Standard Equipment: Drill chuck and key



PROD. NO. MOD. NO.	200225 JDP-13	200275 JDP-13F
Swing	13-1/4"	13-1/4"
Type	Bench Top	Floor Model
Chuck Size	5/8"	5/8"
Drilling Capacity	5/8"	5/8"
Spindle Travel	3-1/8"	3-1/8"
Spindle Distance to Base	24"	48-3/4"
Spindle Distance to Table (Maximum)	17-1/2"	31-1/2"
Table Size (Diameter)	11-3/8"	11-3/8"
Table Tilt (Right and Left)	0° - 45°	0° - 45°
Spindle Taper	MT2	MT2
Column Diameter	2-7/8"	2-7/8"
Number of Spindle Speeds	12	12
Range of Spindle Speeds	280-3,000 RPM	280-3,000 RPM
Overall Height	38-1/2"	61-5/8"
Base size	10" x 16-1/2"	10" x 16-1/2"
Motor	3/4HP, 1PH, 115/230V 5.2/2.6 Amps, Pre-wired 115V	3/4HP, 1PH, 115/230V 5.2/2.6 Amps, Pre-wired 115V
Product Weight	94 lb	107 lb
Shipping Weight	99 lb	112 lb



200225



200275



DRILL PRESSES

17" 1 HP 16 Speed Drill Press

- Powerful 1 horse power motor
- Full 17" swing for easy drilling of larger work pieces
- 16 speed capability allows for a broad assortment of drilling applications
- Magnetic switch
- Fully hinged belt and pulley cover and quick adjust motor mount permit fast changes of spindle speed
- Worktable with quick release clamp rotates and tilts to 45° right and left
- Slots in worktable permit easy clamping of the work piece
- Positive depth setting mechanism uses a threaded rod and two lock nuts for accuracy
- Built-in work lamp with separate switch (bulb not included)

Standard Equipment: Drill chuck and key



2 YEAR
WARRANTY

PROD. NO.
MOD. NO.

200278
JDP-17F

Swing	17"
Type	Floor Model
Chuck Size	5/8"
Drilling Capacity	5/8"
Spindle Travel	3-1/4"
Spindle Distance to Base	48-3/8"
Spindle Distance to Table (Maximum)	28"
Table Size (Diameter)	13-3/4"
Table Tilt (Right and Left)	0° - 45°
Spindle Taper	MT2
Column Diameter	3-1/8"
Number of Spindle Speeds	16
Range of Spindle Speeds	220-3,380 RPM
Overall Height	64-1/2"
Base size	12" x 19-3/4"
Motor	1HP, 1Ph, 115/230V 8.5/4.25 Amps, Pre-wired 115V
Product Weight	176 lb
Shipping Weight	184 lb

22" 1-1/2 HP 12 Speed Drill Press

- Powerful 1-1/2 horse power motor
- Full 22" swing for easy drilling of larger work pieces
- 12 speed capability allows for a broad assortment of drilling applications
- Magnetic switch
- Fully hinged belt and pulley cover and quick adjust motor mount permit fast changes of spindle speed
- Worktable with quick release clamp rotates and tilts to 45° right and left
- Slots in worktable permit easy clamping of the work piece
- Positive depth setting mechanism uses a threaded rod and two lock nuts for accuracy
- Built-in work lamp with separate switch (use outdoor rated bulb, not included)

Standard Equipment: Drill chuck and key



PROD. NO.
MOD. NO.

200357
JDP-22F

Swing	22"
Type	Floor Model
Chuck Size	3/4"
Drilling Capacity	1-1/4"
Spindle Travel	4-1/2"
Spindle Distance to Base	49"
Spindle Distance to Table (Maximum)	29"
Table Size (Diameter)	16-1/2" x 18-3/4"
Table Tilt (Right and Left)	0° - 45°
Spindle Taper	MT3
Column Diameter	3-5/8"
Number of Spindle Speeds	12
Range of Spindle Speeds	180-4,200 RPM
Overall Height	69-1/4"
Base size	19-5/8" x 22-1/2"
Motor	1.5HP, 1Ph, 115/230V 10.0/5.0 Amps, Pre-wired 115V
Product Weight	353 lb
Shipping Weight	373 lb





2 YEAR WARRANTY

3 speed mechanical gearbox



2 YEAR WARRANTY

METAL CUTTING BANDSAWS

4" x 6" 1/3 HP 3 Speed Belt Drive Bandsaw

- Sturdy cast iron saw frame and base
- 1/3 HP motor shuts off automatically when the workpiece is cut through
- Three speeds permit cutting of most materials including metal, plastic and wood
- Designed for horizontal and vertical cutting
- Vise permits mitre cuts to 45° and features a scale for accuracy
- Two wheels and handle permit easy movement
- Convenient shelf mounts under base

Standard Equipment: Blade; stand; wheels; shelf; vertical work table; material stop; vise

PROD. NO.	222326
MOD. NO.	JHVB-46
Capacity 90°	4-1/2" ● 4" x 6" ■
Blade Size	1/2" x 0.025" x 64-1/2"
Vertical Work Table	7" x 8"
Vise Tilts	45°
Blade Speeds (SFPM)	80, 120, 220
Motor	1/3 HP, 1Ph, 115 Volt, 1,725 RPM
Shipping Dimensions	40-1/2" x 12-3/4" x 15-3/4"
Net Weight (approx.)	134 lb
Shipping Weight (approx.)	140 lb

7" x 12" 1 HP 3 Speed Gearbox Bandsaw

- Heavy duty cast iron construction for accuracy and durability
- Three speed gear box replaces less efficient belt drive systems found on most comparable machines
- Horizontal cutting feed rate controlled by a fully adjustable hydraulic ram
- Coolant delivery system provides fast cutting while extending the service life of the blade and the saw
- Quiet cutting, rated within 70 decibels
- Easy cleaning with removable filter screen
- Automatic shut-off system stops the machine when the stock is cut through
- Quick action vise adjusts from 90° to 45° for mitre cutting
- Cuts up to 7" round stock and up to 7" by 12" rectangular stock
- Full 1HP, single phase motor
- Complete with four wheels for mobility

Standard Equipment: Blade; coolant system; material stop system; 4 wheels; vertical work table; enclosed stand; blade chip brush; quick action vise

PROD. NO.	222332
MOD. NO.	JHVG-712
Capacity 90°	7" ● 7" x 12" ■
Capacity 45°	4" ● 5" x 6" ■
Throat Depth	7"
Blade Size	3/4" x 0.032" x 93"
Vertical Work Table	9-1/2" x 10"
Vise Tilts	45°
Blade Speeds (SFPM)	125, 215, 270
Floor Space Required	49-1/2" x 17-1/2"
Motor	1 HP, 1Ph, 115/230 Volt Pre-wired 115V; 1,720 RPM
Shipping Dimensions	51" x 18" x 40"
Net Weight (approx.)	318 lb
Shipping Weight (approx.)	345 lb

9" x 16" 1-1/2 HP 4 Speed Belt Drive Bandsaw

- Designed for industrial use, this saw features a heavy duty steel and cast iron saw frame
- One piece cast iron saw bed
- Enclosed base, welded for strength
- Precision cast 13" blade wheels
- Coolant system includes: pump and reservoir; fully adjustable delivery nozzles at front and rear blade guides; coolant pick-up port in the drive wheel housing; quick-check gauge for coolant level
- Removable chip tray for easy cleaning
- Totally enclosed 1-1/2 HP fan cooled motor with 24 volt controls
- Four speed belt drive system
- Hydraulically controlled feed rate with micro adjust switch
- Automatic shut-off limit switch
- Blade guide system consists of ball bearing thrust roller, ball bearing blade guides and tungsten carbide slides
- Moveable left blade guide arm adjusts from 16" to 7" capacity
- Quick set vise adjusts for 90° to 45° angle cuts
- Material stop with 24" capacity
- Each machine factory tested and set

Standard Equipment: Variable pitch blade; blade chip brush; coolant system; tool kit; quick set vise and material stop

PROD. NO. MOD. NO.	222335 JHBS-916
Capacity 90°	9" ● 4" x 16" - 9" X 12" ■
Capacity 45°	6-1/2" ● 9" X 6-1/8" ■
Throat Depth	9"
Blade Size	1" x 0.032 x 119-1/2"
Blade Speeds (SFPM)	82, 132, 170, 235
Bed Height	25"
Floor Space Required	65" x 28"
Motor (TEFC)	1-1/2HP, 1PH, 230V complete with 24V control panel
Vise Swivels	45°
Wheel Diameter	13"
Net Weight (approx.)	627 lb
Shipping Weight	704 lb







PULLERS





GEAR PULLERS - HEAVY DUTY

Made of the highest quality drop forged
Chrome Vanadium steel for professional use



770134



770135

2 or 3 Jaw Combination Gear Pullers

- Assemble with 3 jaws for maximum stability, or with 2 jaws where access is limited – 2 pullers in 1
- Jaws, yokes and forcing screw made of heat treated Chrome Vanadium steel for ultimate strength
- Reversible jaw design allows internal and external pulling
- Jaws grip tighter as pulling force increases
- All components hardened to HRC 42~45 for professional use
- Fine-threaded 440 CrV forcing screw allows precise control for damage free pulling
- Can be used with bearing separators

PROD. NO.	MOD. NO.	Reach	Spread	Capacity	Screw Length	Pitch	Jaw Thickness	Jaw Width
770132	JGP-3HD	3-1/4"	4-3/4"	2 tons	4.9"	3/8"-24 tpi	1/8, 1/4"	1/4, 7/16"
770133	JGP-4HD	3-1/2"	7"	5 tons	7"	9/16"-20 tpi	3/8, 3/4"	1/4, 5/16"
770134	JGP-6HD	5-1/2"	7"	5 tons	7"	9/16"-20 tpi	1/4, 5/16"	3/8, 3/4"
770135	JGP-8HD	5-1/2"	9-1/2"	5 tons	9"	11/16"-18 tpi	5/16, 11/32"	7/8"

CrV

Hydraulic Gear Puller Set

770152 / JHGP-10S

- Jaws, yokes, bearing separator and ram made of heat treated Chrome Vanadium steel for ultimate strength
- Hydraulic ram requires no power - develops up to 10 tons of pressure with hand power only
- All components hardened to HRC 42~45 for professional use
- Includes twin and triple heads for assembling 2 jaw and 3 jaw pullers
- Includes 4-1/2" bearing separator
- Comes in a convenient blow mould storage case

Reach	Spread	Capacity	Pieces (total)
4"	10"	10 tons	22

Contents: Hydraulic Ram (1), 4" Puller Legs (3), 6" Puller Legs (3), 8" Puller Legs (3), Collar (1), Twin Head (1) Triple Head (1), End Cap (1), 2" Ram Extension (1), Yoke (1), 4-1/2" Bearing Separator (1), Main Rods (2), Extension Rods (2)



770152

BEARING SEPARATORS - HEAVY DUTY

- Separator bodies made of heat treated Chrome Vanadium steel for maximum strength
- All components hardened to HRC 42~45 for professional use
- Separators have knife like edges to get behind bearings where regular gear puller jaws are too thick to grip
- Can be used with push or pull type gear pullers

12 Piece Set

770302 / JBS-12

Maximum Reach	Capacity	Forcing Screw	Hole Size
3"	5 tons	7", 9/16" x 10 tpi	3/8" x 16 tpi

Contents: 2-1/4" Bearing Separator (1), 3-1/2" Bearing Separator (1), Yoke (1), Forcing Screw (1), Main Rods (4), Extension Rods (4)



770302

Open Stock

PROD. NO.	MOD. NO.	Capacity	Hole Size
770312	JBS-225	1-3/16" - 2-1/4"	3/8" x 16 tpi
770313	JBS-350	2-1/4" - 3-1/2"	3/8" x 16 tpi
770314	JBS-450	3" - 4-1/2"	1/2" x 16 tpi



GEAR PULLERS

See page 291 in the Specialty Auto section for similar products



SPECIALTY PULLERS

JET carries a complete line of Specialty Automotive pullers for every need.



H3341



H1921



H1901



H1903



H1905

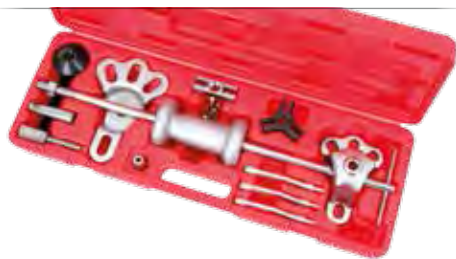

H3560



H3565



H3566



H3562

LUBRICATION & FLUID TRANSFER





GREASE GUNS

Lever Action

350151 / JLGG-14S



- Uses standard 14 oz. grease cartridge or can be bulk filled
- Rugged electro-static epoxy coated finish resists corrosion
- Deep knurling for non-slip grip
- Heavy duty steel barrel for long life
- Machined steel head protects hardened steel plunger
- V-handle posi-lock follower rod for sure grip and easy filling in any position
- Ideal for home, farm, maintenance and shop use
- Complete with 6" rigid pipe extension and coupler
- Delivers 1 gm/stroke or 1 oz./28 strokes
- Produces up to 6,000 PSI

Lever Action – Heavy Duty

350152 / JLGG-14HD



Die cast head

Comes with rigid extension

- A premium, heavy duty grease gun built tough for the professional, industrial markets
- Added filler nipple allows three way loading; bulk, filler pump or standard 14 oz. cartridge
- Air bleeder valve easily purges unwanted air
- Variable stroke for working in confined areas
- Rugged electro-static epoxy coated finish resists corrosion
- Deep knurling for non-slip grip
- Heavy duty steel barrel for long life
- Die cast head protects hardened steel plunger
- T-handle posi-lock follower rod for sure grip and easy filling in any position
- Comfortable sure grip rubber handle makes pumping easy and convenient
- Complete with 6" rigid extension and heavy duty coupler
- A must for heavy maintenance, industrial, automotive and farm use
- Delivers 1 gm/stroke or 1oz./28 strokes
- Produces up to 10,000 PSI

Pistol Grip – Heavy Duty

350155 / JPGG-14HD



Die cast head

Comes with rigid and flex extension

- Pistol grip design offers convenient one-handed operation
- Die cast head protects hardened steel plunger
- Uses standard 14 oz. grease cartridge or can be bulk filled
- Rugged electro-static epoxy coated finish resists corrosion
- Deep knurling for non-slip grip
- T-handle posi-lock follower rod for sure grip and easy filling in any position
- Includes 4" rigid pipe extension, 18" flexible hose and heavy duty coupler
- Delivers 0.50 gm/stroke or 0.70 oz./40 strokes
- Produces up to 5,000 PSI

High Pressure / High Volume - Heavy Duty

350156 / JPGG-14HPHV

- Convenient lever mounted switch converts gun for high pressure or high volume use while maintaining one-hand operation
- Threadless barrel with quick connect lever allows for super-fast reloading with no danger of crossing threads
- Uses standard 14 oz. grease cartridge or can be bulk filled
- Complete with air bleeder and bulk loader valves
- Deep knurling for non-slip grip
- T-handle posi-lock follower rod for sure grip and easy filling in any position
- Includes 12" Heavy Duty flexible hose and coupler
- Delivers 0.90 gm/stroke or 1 oz./31 strokes
- Produces up to 7,000 PSI



All-Weather Pistol Grip Grease Gun – Heavy Duty

350165 / JPPGG-14AW

- Specially designed to outperform in cold weather
- Large grease inlet with bleeder valve helps retain prime
- Double-lipped follower allows use with grease cartridge or bulk loading
- Pistol grip with compression spring for greasing with minimal effort
- Complete with 18" high pressure hose and professional 4-jaw coupler
- Delivers 1oz/40 strokes
- Produces up to 7,500 PSI



NEW

18 V Cordless Grease Gun – Heavy Duty

350166 / JCGG18

- Includes 2 long-life rechargeable 18 V batteries and 1 hour charger
- Complete with 42" high pressure flex hose and professional 4-jaw coupler
- Specs: 10 000 PSI; dispenses 2 oz/min
- Accepts standard 14oz cartridge, or can be bulk filled
- Includes durable plastic storage case and shoulder strap

NEW





Comes with rigid and flex extension



Pre-loaded with NLGI Grade 2 grease

GREASE GUNS

Single Shot Air Powered – Heavy Duty

350161 / JAGG-14P

- A premium heavy duty air powered grease gun for the most demanding professional user
- Intermittent action delivers one shot of grease for every pull of the trigger
- Added filler nipple allows 3 way loading; bulk, filler pump, or standard 14 oz. cartridge
- Heavy duty die cast aluminum head
- Precision honed barrel for fast action
- Air pressure 40-120 PSI at 1 cfm or greater
- T-handle posi-lock follower rod for sure grip and easy filling in any position
- Complete with male quick coupler air fitting
- Delivers 0.90 gm / shot or 1.30 oz./40 shots
- Produces up to 4,800 PSI
- Includes 6" rigid extension, 12" flexible hose and heavy duty coupler

Continuous Flow Air Powered – Heavy Duty

350162 / CFAGG-14HD

- Automatic continuous flow of grease while trigger is depressed
- 40:1 Pump Ratio
- Minimum inlet air pressure 40 PSI to Maximum 120 PSI (2.7 to 10.3 bar)
- Develops up to 4,800 PSI pressure
- Added filler nipple allows 3 way loading; bulk, filler pump, or standard 14 oz. cartridge
- Air vent valve included for releasing air pockets
- Output per stroke 14 oz. per minute
- Lubricant up to NLGI #2 Grease
- Air Inlet 1/4-18 NPT
- Grease Outlet 1/8-27 UNPT
- Includes 6" rigid extension, 12" flexible hose and heavy duty coupler

Pistol Grip - Mini Style - Heavy Duty

350171 / JMPG-16

- Convenient pull type trigger for easy one hand operation
- Die cast head
- Textured zinc plated finish for non slip grip
- Uses standard 3 oz. grease cartridges or can be bulk filled (grease not included)
- T-handle posi-lock follower rod for sure grip
- Complete with 4" rigid pipe extension and professional coupler
- Produces up to 3,500 PSI
- Delivers 0.40 gm/stroke or 0.60 oz./40 strokes

Push Type - Mini Tool Box Style

350173 / JPTG-1

- Perfect tool box companion for lubrication of tools on the job
- Universal connector fits all standard fittings
- Comes pre loaded with NLGI grade 2 grease
- Can be re-filled
- Transparent barrel provides clear view of remaining grease
- Sealed design to prevent leakage

- Replacement whip hoses
- Polyimide inner tube with polyurethane outer tube, reinforced with highly tear resistant polyester

High Pressure - Regular Style

- Heavy duty high pressure (11,600 PSI burst pressure)
- Working pressure 3,500 PSI

PROD. NO.	MOD. NO.	Length	Type	Thread
350181	JFH-12	12"	Flexible	1/8" NPT
350182	JFH-18	18"	Flexible	1/8" NPT

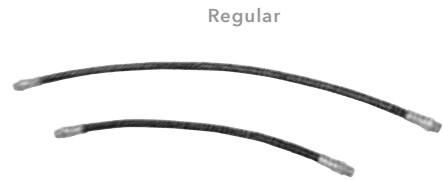

High Pressure - Spring Style

- Fitted with heavy duty spring for added safety, strength and life
- Heavy duty high pressure (11,600 PSI burst pressure)
- Working pressure 3,500 PSI

PROD. NO.	MOD. NO.	Length	Type	Thread
350201	JFH-12SP	12"	Flexible	1/8" NPT
350202	JFH-18SP	18"	Flexible	1/8" NPT



High Pressure - Super Heavy Duty

- Two layer construction consisting of polyamide inner tube with a tough polyurethane sheath, reinforced diagonally with high tear resistant polyester
- Extra large inner diameter is ideal for cold weather use
- Spring guard adds strength and safety
- For hand and air operated grease guns and control valves
- Working pressure 5,800 PSI
- Burst pressure 13,775 PSI

PROD. NO.	MOD. NO.	Length	Type	Thread
350215	JFH-12HP	12"	Flexible	1/8" NPT
350216	JFH-18HP	18"	Flexible	1/8" NPT





GREASE GUN ACCESSORIES QUICK CHANGE COUPLER ADAPTERS



7 PC Quick Change Coupler Set

350213 / JQCC-7S

- Quick change feature snaps directly onto jaw type couplers - no need to remove hydraulic coupler to change accessories
- Instantly converts jaw type couplers for fine line greasing for access to confined areas
- Protective sleeve secures connection
- Ideal for applications where fittings are in hard-to-reach areas
- For hand operated grease guns
- **Set contains one of each depicted (except 350205)**



Recessed Lube Adapter

350208 / JRLA-1

- 4" length, tip diameter 0.22"
- For push on greasing of fittings where obstruction will not allow use of regular coupler



Right Angle Coupler

350211 / JRAC-2

- Working pressure 1,00 PSI
- Particularly useful in low height applications
- Polyurethane seal fits perfectly on grease fitting



Needle Nose Adapter

350210 / JNND-2

- 1-1/2" needle length, diameter 0.156"



Grease Injector Needle

350206 / JGIN-15

- Lubricates in extremely tight places including U-joints and sealed bearings
- Fits directly on jaw type couplers
- 18 gauge stainless steel
- 1-1/2" long
- With protective plastic cover



Seal-Off Dispenser

350212 / JSOD-1

- Used for lubricating cars with grease plugs
- Oil and grease resistant rubber tip



90° Angle Lube Adapter

350209 / JALA-1

- 0.19" diameter



Needle Nose Dispenser

350205 / JNND-1

- For dispensing fine line of grease
- Allows contact with flush or hard-to-reach fittings in inaccessible areas
- 1-1/2" needle length, diameter 0.156"
- 1/8" NPT threads

GREASE GUN COUPLERS



- For hand operated grease guns
- Professional industrial quality

4 Jaw - Heavy Duty 350203 / JPDC-4

- Hardened body withstands high pressure without deformation
- Working pressure 6,000 PSI
- 1/8" NPT threads



350203

Button Head - Heavy Duty

- Specifically designed to fit 5/8" and 7/8" button head fittings found on heavy machinery
- Metal seal resists wear

PROD. NO.	MOD. NO.	Threads	Working Pressure
350217	JBHC-58	1/8" NPT	6,000 PSI
350218	JBHC-78	1/8" NPT	7,500 PSI



350218



350217

Right Angle - Heavy Duty 350204 / JRAC-1

- Unique design for greasing fittings in hard-to-reach areas
- Particularly useful in low height applications
- Polyurethane seal fits perfectly on grease fitting
- Working pressure 1,000 PSI
- 1/8" NPT thread



350204

Swivel Type - Heavy Duty 350207 / JSGC-360

- Built in 360° swivel locks in eight positions
- Working pressure 7,000 PSI
- 1/8" NPT threads
- Fully hardened 3-jaw construction



350207

GREASE GUN HOLDERS

Grease Gun Holder 350185 / JGGH-1

- Conveniently mounts any 2-1/4" O.D. grease gun to almost any surface



350185

Grease Gun Holder - Heavy Duty 350189 / JGGH-2HD

- Designed specifically for mounting on construction equipment, farm vehicles, tractor trailers and other vehicles subject to high vibration
- Heavy duty spring retains gun securely and allows easy removal and replacement
- Four mounting bolts for secure attachment
- Fits 2-1/4" and 2-1/2" barrel diameters



350189



GREASE FITTINGS

- Conforms to SAE, DIN, BS and JIS standards
- EN-1A steel with zinc plating
- Heat treated to a minimum of HRC83



350259 / 350260



350263



350264

Sets - Heavy Duty

PROD. NO.	MOD. NO.	Type	Pieces	Contents
350257	JGF-8S	SAE	8	2 each: 1/4" - 28 Straight, 1/8" - 27 Straight, 1/8" - 27 45°, 1/8" - 27 90°
350258	JGF-8M	Metric	8	2 each: M6 x 1 Straight, M6 x 1 45°, M6 x 90°, M8 x 1
350259	JGF-80S	SAE	80	15 x 1/4" - 28 Straight, 10 x 1/4" - 28 45°, 10 x 1/4" - 28 90°, 25 x 1/8" - 27 Straight, 10 x 1/8" - 27 45°, 10 x 1/8" - 27 90°
350260	JGF-80M	Metric	80	20 x M6 x 1 Straight, 10 x M6 x 1 90°, 15 x M8 x 1 Straight, 10 x M8 x 1 90°, 15 x M10 x 1 Straight, 10 x M10 x 1 90°
350263	JGFK-101	SAE	101	1/8"-27 NPT: 22 Straight, 5 x 30°, 10 x 45°, 10 x 65°, 10 x 90° 1/4"-28 SAE-LT: 22 Straight, 10 x 45°, 10 x 90° 350261 (JGFT-14) and 350262 (JGFT-18) fitting tools



350257 / 350258

40 PC SAE Stainless Steel Grease Fitting Set - Heavy Duty

350264 / JGFK-40SS

- Stainless steel fittings for use in marine and other corrosive environments
- CONTENTS:**
- 1/8"-27 NPT: 10 straight, 5x45°, 5x90°
 - 1/4"-28 SAE-LT: 10 straight, 5x45°, 5x90°



STRAIGHT
350251 / 350254



45°
350252 / 350255



90°
350253 / 350256



10 Packs - Heavy Duty

PROD. NO.	MOD. NO.	Type	Pieces	Thread	Hex Size
350251	JGF-142800	Straight Fittings	10	1/4" - 28 SAE	5/16"
350252	JGF-142845	45° Fittings	10	1/4" - 28 SAE	3/8"
350253	JGF-142890	90° Fittings	10	1/4" - 28 SAE	3/8"
350254	JGF-182700	Straight Fittings	10	1/8" - 27 NPT	7/16"
350255	JGF-182745	45° Fittings	10	1/8" - 27 NPT	7/16"
350256	JGF-182790	90° Fittings	10	1/8" - 27 NPT	7/16"

Grease Fitting Unblocker 350265 / JFUT-100

- Opens clogged grease fittings and loosens hardened grease joints
- Tapping tool with a hammer forces a light viscosity oil into the fitting, breaking up and removing dirt and debris
- Excellent for maintaining bearings, control arms, king pins etc.
- Built-in hand guard for operator protection
- Complete with coupler and flex hose for reaching recessed fittings
- Includes 2 spare piston seals



350265

4 Way Fitting Tools

- Handy multi-purpose fitting tools
- Wrench, tap and extractor in one
- Removes worn and broken fittings, re-taps threaded holes, installs new fittings
- Works with straight and angled fittings

PROD. NO.	MOD. NO.	Application
350261	JGFT-14	<ul style="list-style-type: none"> • Tap repairs 1/4"-28 SAE threaded holes • Wrench removes and installs 5/16" and 3/8" hex fittings
350262	JGFT-18	<ul style="list-style-type: none"> • Tap repairs 1/8"-27 NPT threaded holes • Wrench removes and installs 7/16" and 3/8" hex fittings



350262



350261



GREASE PUMPS

Grease Gun Filler Pump

350158 / JGFP-03

- Zinc die cast head and adjusting flange
- 18" zinc plated pump body
- Epoxy coated, corrosion resistant 12" drum cover
- All steel foot valve
- Fits 25 - 50 lb / 5 gallon pails
- Designed to load bulk or combination grease guns
- Delivers 28 gms on 1oz./stroke
- Suitable for use with light and medium density grease

50:1 GREASE PUMPS

- Designed for everyday use in shops, factories and maintenance departments for quick and efficient dispensing of grease
- All units dispense 27 ounces per minute. Simply connect to your air system, pull the trigger and let these powerful pumps do the work
- Each unit comes with 18" whip hose/coupler, control valve, 4 meters of hose, drum cover and follower plate



50 lb Air Operated Grease Pump Kit - Heavy Duty

350306 / JAGP-25

- 50:1 Air Operated Grease Pump (25-50 lb container)
- Requires 70-115 PSI operating pressure
- Pumps up to 1.76 lb per minute (27 ounces)
- 82 dB noise level
- 13' delivery hose
- 12-13/64" drum cover
- 10-3/8" follower plate
- Control valve
- Shipping Weight: 23 lb (10kg)



120 lb Air Operated Grease Pump Kit - Heavy Duty

350307 / JAGP-120

- 50:1 Air Operated Grease Pump (120 lb container)
- Requires 70-115 PSI operating pressure
- Pumps up to 1.76 lb per minute (27 ounces)
- Comes with 4 wheel roll around cart
- 82 dB noise level
- 13' delivery hose
- 15" drum cover
- 14-1/2" follower plate
- Control valve
- Shipping Weight: 38 lb (17 kg)



Control Valve

350311 / JAGP-CV

- Premium quality, top of the line grease control valve for use with air operated equipment
- Provides continuous grease flow with trigger fully depressed
- Inlet thread: 1/4" NPTF



Booster Grease Control Valve

350312 / BGCV-1

- Heavy duty grease control valve with built-in pressure boost mechanism
- Repeated actuation of handle boosts line pressure from 6,000 PSI up to 10,000 PSI
- Provides continuous flow with handle fully depressed
- Extremely useful for unblocking clogged fittings
- Complete with 6" rigid extension and 4 jaw heavy duty coupler
- Inlet thread 1/4" NPTF



360° Swivel

350391 / JAGP-SW

- 1/4"(M) x 1/2"-27(M)
- Installed between the delivery hose and grease control valve allowing greater mobility and control of the grease control valve
- Heavy duty steel construction with ball bearings for smooth operation and unrestricted movement
- Swivel joints are hardened for durability and greater wear resistance
- Maximum working pressure - 6,000 PSI





WATER, CHEMICAL AND OIL PUMPS

Polyethylene Siphon Pumps

- Easy to use pumps siphon liquids to lower levels automatically once started
- 6 to 7 strokes of the bellows primes pump requiring no further operation
- Vent cap stops siphoning when opened
- Bellows can be continuously operated to pump liquids to higher levels than pump is installed
- Complete with flexible discharge hose
- **Recommended use:** water-based fluids, detergents, waxes, soaps, antifreeze, mild acid solutions, and other lightweight non-flammable liquids
- **Do not use with:** concentrated acids, acetone, benzene, fuels, fluids incompatible with wetted components, or liquids above 60°C (140°F)
- Wetted components: polyethylene

PROD. NO.	MOD. NO.	Discharge	Bung Size	Fits	Wetted Components	Discharge Hose Length
350110	JPSP-2	2 GPM (6.5 LPM)	1-1/2"	5 gal / 5-20 l pails	Polyethylene	21-1/2"
350111	JPSP-5	5 GPM (17.5 LPM)	2"	55 gal / 205 l drums	Polyethylene and Polypropylene	46-1/2"
350112	JPSP-7	7 GPM (21 LPM)	2"	55 gal / 205 l drums	Polyethylene and PVC	47-3/4"

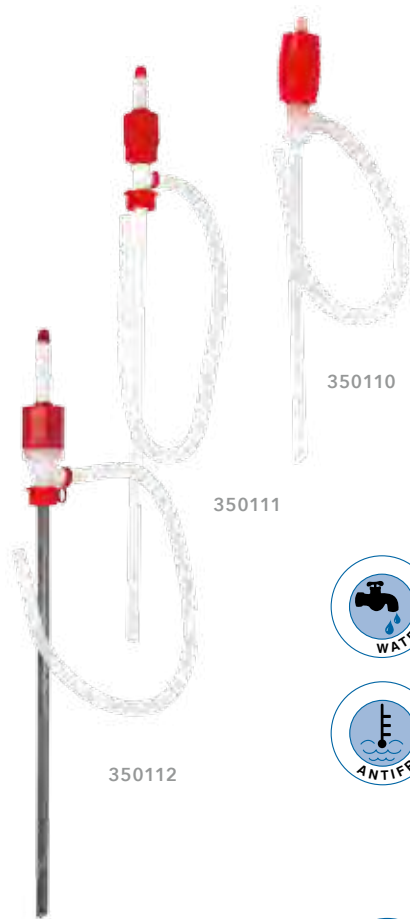

Chemical Pump - Nylon Body

350109 / JNCP-14

- Self-priming vertical lift pump
- Fits 15 - 55 gallon drums
- Delivers 14 oz. per stroke
- **Recommended use:** lacquer thinners, acetone, MEK, antifreeze, detergents, windshield washer fluids, mild acids, weed killer, water and glycerine
- **Do not use with:** strong acids or gasoline
- Wetted components: nylon, polypropylene, stainless steel and PTFE

Chemical Pump - Polypropylene Body

350108 / JPCP-14

- Self-priming vertical lift pump
- Fits 15 - 55 gallon drums
- Delivers 14 oz. per stroke
- **Recommended use:** antifreeze, detergents, windshield washer fluid, mild acids and glycerine
- **Do not use with:** water, strong acids, lacquers, acetone and gasoline
- Wetted components: polypropylene, steel, Viton^f

Plastic Lever Pump

350113 / JPLP-100

- Lever action barrel pump designed for use with high viscosity fluids
- Special design makes pumping thick liquids easier reducing operator fatigue
- Built in 2" bung adapter with lock nut allows pump handle to be positioned conveniently
- Air vent cap stops siphon action
- Delivers 500 ml per stroke
- For use on 15 - 55 gallon (50 - 205 litre) drums
- Complete with 6' corrugated discharge hose
- **Recommended use:** water-based fluids, detergents, waxes, soaps, antifreeze, windshield washer fluid, hydraulic oils, lubricants, pesticides and herbicides, Adblue®, Urea, DEF and other non-flammable liquids
- **Do not use with:** concentrated acids, acetone, benzene, fuels, thinners, solvents or fluids incompatible with wetted components
- Wetted components: polyacetal, polypropylene, polyethylene, PVC, Viton®



OIL AND FUEL PUMPS

Oil Cans

- Industrial quality
- Brass pump
- Electro-static, corrosion resistant epoxy coating
- Complete with flex hose and rigid spout

Brass Pump Oil Cans

PROD. NO.	MOD. NO.	Capacity
350121	JOC-180	6 oz. / 180 ml
350122	JOC-300	10 oz. / 300 ml
350124	JOC-500	16 oz. / 500 ml
350125	JOC-700	24 oz. / 700 ml

350125



All models complete with both flex and rigid spouts



OIL AND FUEL PUMPS

Barrel Pump - Lever Action - Heavy Duty

350105 / JLBP-01



- Suitable for use with all oil based fluids
- Fits 15 - 55 gallon drums
- Rugged epoxy coated pump assembly
- Tough all steel foot valve and piston valve
- Delivers 300 ml or 10 oz. / stroke
- Complete with 2 piece draw tube

Bucket Pump - Lever action - Heavy Duty

350106 / JLBP-02



- Suitable for transfer of transmission, differential and heavier oils
- Delivers 16 oz. / stroke
- Zinc die cast head and adjustable flange
- Fits 25 - 50 lb / 5 gallon pails
- Epoxy coated, corrosion resistant 12" drum cover
- 18" zinc plated pump body
- Complete with 48" fuel resistant soft PVC hose with nozzle

Suction Gun

350157 / JSGG-18



- Rugged 18 oz. capacity suction gun for draining and filling differentials, clutches and transmissions
- Does not require priming
- Heavy duty steel barrel for long life
- Electro-static epoxy coated finish resists corrosion
- Deep knurling for non-slip grip
- T-handle posi-lock follower rod for sure grip
- Complete with flexible vinyl hose
- For use with any non-corrosive lubricants



Brass Transfer Pump

350159 / JBTP-100



- Portable hand pump for quick and easy transferring or evacuating of a wide variety of media
- Non-corroding premium brass construction
- Self-priming
- Complete with 24" of 1/2" discharge hose and 40" of 1/4" suction hose
- Can be used to drain oil or transmission fluids through the dipstick hole - ideal for boats
- Transfer fluids from one container to another without lifting either
- Pumps 3.2 oz. (100ml) per stroke
- Wetted components: brass, neoprene

Barrel Pump - Rotary - Heavy Duty

350103 / HRP-25

- Sturdy cast iron body with precisely machined cast iron vanes for better draw and smoother delivery
- Hi-Nitrile rubber pump seals
- Delivers 5 litres or 1.30 gallons per 20 revolutions
- Dual directional operation – pumps in either direction
- **Recommended use:** diesel, kerosene, heating oils, motor oils, lubrication oils (up to SAE 90) and other non-corrosive media
- **Do not use with:** gasoline, antifreeze, solvents, acids or water based media
- Comes with suction tube, 2" cast iron bung nut and steel discharge spout

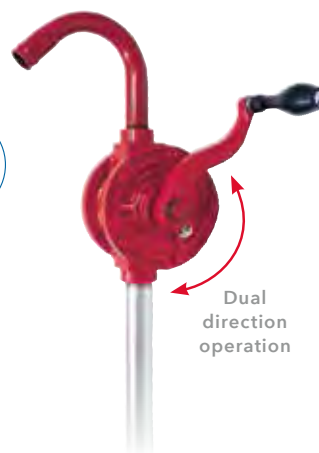

Dual direction operation

Plastic Rotary Pump

350114 / JPRP-200

- Rotary barrel pump designed for use with media which cannot be pumped with cast iron or steel pumps
- Glass filled polypropylene body with Ryton® vanes, Viton® seals and stainless steel hardware for maximum resistance to chemicals
- Strainer fitted on suction tube prevents contaminants from entering pump
- Delivers 1 litre per 4 turns
- Includes 2" threaded bung adapter
- For use on 15 - 55 gallon (50 - 205 litre) drums
- **Recommended use:** water-based fluids, antifreeze, Adblue®, urea, DEF, benzene, detergents, glycerine, acids, chemicals, oils, diesel, kerosene
- **Do not use with:** acetone, lacquer, mineral oils, solvents, turpentine, gasoline or fluids incompatible with wetted components
- Wetted components: polypropylene, Ryton®, Viton®, stainless steel



Litre Stroke Pump

350115 / JLSP-100

- Designed to dispense exact amounts of petroleum based fluids
- Adjustment screw allows pump to be set to deliver 1 litre or 1 quart per stroke
- Rack and pinion mechanism is very precise; ideal for applications requiring metered delivery
- Spring loaded drain-back tube returns overflow to the drum via the suction tube
- Handle can be padlocked for security
- Lock nut allows outlet to be positioned in any direction
- Complete with 2" bung adapter
- For use on 15 - 55 gallon (50 - 205 litre) drums
- **Recommended for:** gear and lube oils, petroleum based fluids, diesel fuel, kerosene
- **Do not use with:** water based, corrosive fluid, gasoline or liquids incompatible with wetted components
- Wetted components: steel, aluminum, nitrile rubber and acetal





FUEL AND GASOLINE PUMPS



Rotary Fuel Pump

350116 / JRF-10

- Industry standard for rotary pumps
- Designed for severe use in extreme weather conditions
- Solid cast iron body CNC machined to exacting tolerances
- High quality sintered powder metal 3 vane rotor operates in a highly finished pumping chamber
- Non-wearing graphite vanes and graphite seal allows pumping of a wide variety of fluids including those with up to 15% ethanol
- Discharges up to 10 GPM (38 LPM)
- Complete with 2" bung adapter and telescopic suction tube with strainer
- For use on 15 - 55 gallon (50 - 205 litre) drums
- **Recommended use:** gear and lube oils, petroleum based fluids, diesel fuel, kerosene and gasoline
- **Do not use with:** water based, corrosive fluids or fluids incompatible with wetted components
- Wetted components: cast iron, steel, graphite, paper, polypropylene

Rotary Fuel Pump Kit

350117 / JRF-10K

- Industry standard for rotary pumps
- Designed for severe use in extreme weather conditions
- Complete with 8' anti-static discharge hose and non-sparking aluminum nozzle and nozzle holder for re-fueling operations
- Solid cast iron body CNC machined to exacting tolerances
- High quality sintered powder metal 3 vane rotor operates in a highly finished pumping chamber
- Non-wearing graphite vanes and graphite seal allows pumping of a wide variety of fluids including those with up to 15% ethanol
- Discharges up to 10 GPM (38 LPM)
- Complete with 2" bung adapter and telescopic suction tube with strainer
- For use on 15 - 55 gallon (50 - 205 litre) drums
- **Recommended for:** gear and lube oils, petroleum based fluids, diesel fuel, kerosene and gasoline
- **Do not use with:** water based, corrosive fluid, or fluids incompatible with wetted components
- Wetted components: cast iron, steel, graphite, paper, polypropylene

3:1 High Volume Rotary Fuel Pump

350118 / JRFP-300

- Geared rotary barrel pump turns rotor 3 times for each turn of the handle
- Dispenses up to 55 gallons (205 litres) in just 3 minutes
- Ideal for use where volume fuel dispensing is required
- Die cast aluminum pump body with die cast zinc rotor and vanes
- Built-in nozzle holder
- Handle can be locked for security
- Complete with 6' fuel resistant discharge hose
- Complete with 2" bung adapter and 3 piece threaded tube
- For use on 15 - 55 gallon (50 - 205 litre) drums
- **Recommended use:** gasoline, diesel fuel, and kerosene
- **Do not use with:** water based or corrosive liquids, solvents, acids, alkalis or fluids incompatible with wetted components
- Wetted components: aluminum, zinc, steel, NBR and PVC Nitrile

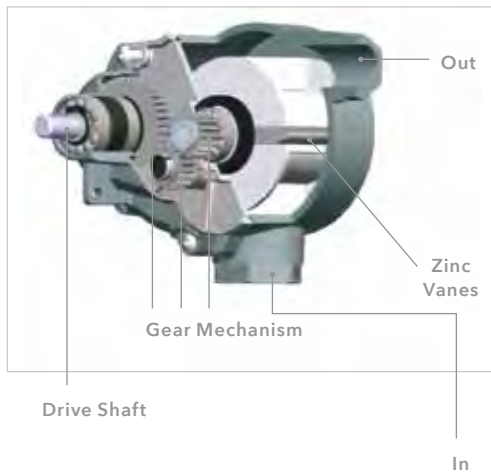

Diaphragm - Litre Stroke - Heavy Duty

350107 / JDDP-1000

- High volume double action pump delivers on both strokes for fast fuelling
- Delivers 1 litre per cycle or 1 gallon / 5 strokes
- Fits 15 - 55 gallon drums
- Die cast aluminum construction
- Stainless steel piston and fuel resistant diaphragm
- Extra heavy duty steel handle with security locking latch
- Complete with 2" bung adapter, 8' discharge hose and telescoping suction tube
- **Recommended use:** gasoline, diesel fuels, fuel oil, motor oil
- **Do not use with:** corrosive liquids, solvents, alkalis, or fluids incompatible with wetted components
- Wetted components: aluminum, steel, stainless steel, polyacetal, NBR



OIL DRAINS



24 US Gallon (90 Litre) Waste Oil Drain - Heavy Duty

350511 / JOIDR90

- Large 90 litre steel recovery tank
- 78" long drainage hose
- Tank mounted oil-level sight gauge
- Convenient tool tray
- 16" diameter collection funnel holds 18 litres of oil
- 23" diameter collection funnel adapter included to expand oil catch area
- Shut off valve between collection funnel and tank allows fluid inspection prior to draining oil
- Uses air to pressurize tank, allowing quick and easy fluid evacuation (maximum 7 PSI)
- Pressure regulator included
- Adjustable bowl height from 40" to 79" high
- Uses gravity to drain waste oil from engines, gear boxes, and differentials
- Shipping weight: 60 lb (27 kg)



18 US Gallon (68 Litre) Waste Oil Drain

350512 / JOIDR68GD

- 68 litre steel recovery tank
- 8' drainage hose doubles as an oil level sight gauge
- 14" metal collection funnel holds 10 litres of oil
- Shut off valve between funnel and tank allows fluid inspection prior to draining oil
- Uses air to pressurize tank, allowing quick and easy fluid evacuation (maximum 10 PSI)
- Pressure regulator included
- Adjustable bowl height from 46 to 75"
- Uses gravity to drain waste oil from engines, gear boxes and differentials
- Shipping weight: 58 lb (26 kg)

17 US Gallon (64 Litre) Low Profile Polypropylene Oil Drain 350514 / JOIDRLP

- Ideal for draining oil where a pit or hoist is not available
- 17 US Gallon tank with integrated baffle captures oil and minimizes spillage during transport
- Convenient rotary hand pump for fast evacuation to large oil collection tanks
- Large metal screen keeps foreign matter out of recovery tank
- Long steel handle eases moving and positioning of drain
- Shipping Weight: 46 lb (21 kg)



15 US Gallon (56 Litre) Low Profile Steel Tank Oil Drain 350515 / JOIDRLPM

- Ideal for draining oil where a pit or hoist is not available
- 15 US Gallon tank with integrated baffle captures oil and minimizes spillage during transport
- Convenient rotary hand pump for fast evacuation to large oil collection tanks
- Large metal screen keeps foreign matter out of recovery tank
- Long steel handle eases moving and positioning of drain
- Shipping Weight: 46 lb (21 kg)



17 US Gallon (64 Litre) Low Profile Polypropylene Antifreeze Drain 350520 / JOIDRLPAF

- Ideal for draining antifreeze where a pit or hoist is not available
- 17 US Gallon tank with integrated baffle captures antifreeze and minimizes spillage during transport
- Convenient rotary hand pump for fast evacuation to large collection tanks
- Aluminum pump body specifically designed to pump corrosive antifreeze
- Large metal screen keeps foreign matter out of recovery tank
- Long steel handle eases moving and positioning of drain
- Shipping Weight: 46 lb (21 kg)



9L Manual Fluid Extraction Pump 350551 / JMPE-9

- Quickly and efficiently evacuates a multitude of fluids, including engine oil, transmission fluids, gear oil, and brake fluid
- Includes one brake line flex hose, two dipstick hoses, and a line clearing tool
- Features a durable rust and corrosion resistant polyethylene construction
- Quick-drain pour spout

NEW





DRUM HANDLING



Drum Wrench - Aluminum Handle

350214 / JADW-1

- Designed to fit perfectly onto most 2" and 3/4" drum plugs
- Made of cast aluminum for strength and safety
- Will not cause sparks
- Hardened and tempered



351003

Drum Dollies

- Heavy gauge steel for professional use
- Powder coated finish
- 5 and 16 gallon models with adjustable clamp bolt
- 16 and 55 gallon models complete with cast iron casters



351004

Cast iron
casters

PROD. NO.	MOD. NO.	Application	Wheels	Load Limit	Diameter
351003	JDD-5	5 gallon drums	Resin	200 lb	10-1/4 - 11-1/4"
351004	JDD-16	16 gallon drums	Super Heavy Duty Cast Iron	200 lb	13-1/2 - 14-1/4"
351005	JDD-55	55 gallon drums	Super Heavy Duty Cast Iron	450 lb	23"

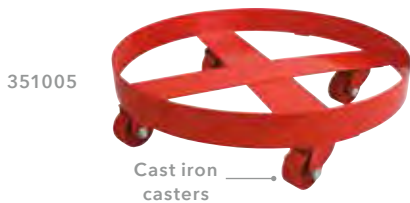

351005

Cast iron
casters



Drum Cradle

351011 / JDC-55

- Tilting drum cradle moves, rotates, tips and stores 55 gallon drums with ease
- Self storing lever bar
- Powder coated finish
- Flat packed for easy shipping
- 2-1/2" non-sparking wheels
- Load limit: 600 lb (270 kg)

JET



SPECIALTY AUTOMOTIVE





BRAKE REPAIR TOOLS

Brake Adjusting Tool - Universal

H1085

- Ground and tapered for easy access to most applications
- Lustre plated for rust protection
- Blade width: **5/8"**
- Overall Length: **9"**

Brake Adjusting Tool - Short

H1107

- This short length tool is popular as it gets into many tight spots found on today's cars
- Curved and ground for universal use
- Lustre plated for rust protection
- Blade width: **1/2"**
- Overall Length: **7"**

Brake Shoe Retaining Spring Tool

H1096

- Dual size for dish type washers
- Used for removing the dish type washer on brake shoe hold down spring
- Knurled cup securely grips washer
- Notched for washer with ears
- Fits many imports with smaller hold down springs
- Plastic handle
- Bright lustre plated
- Range: **5/8 - 7/8" diameter washers**

Brake Spring Pliers

H1103

- Removes and installs brake springs on majority of cars and trucks
- Forged from alloy steel and heat-treated for long wear
- Designed with narrow points for inline pull on the springs
- Equipped with special Bendix® socket on one end
- Overall length: **13"**

Rear Disc Brake Piston Tool

H3070

- Designed to rotate the rear parking brake piston back into the caliper cylinder when replacing worn brake pads on vehicles equipped with four wheel disc brakes
- Will work on most Ford®, Chrysler®, some GM® models, and some imports

Tube Bender - Heavy Duty

H1278

- Bend thin wall tubing 360° with this heavy duty bender
- For use in automotive, plumbing, heating, refrigeration and marine applications
- Range: **1/8" - 1/2" O.D. tubing**



Pliers Type Tube Bender - Heavy Duty

H3342

- Bends copper or steel tubing without kinking or collapsing
- Comes with two roller adapters
- Bends **3/16", 1/4", 5/16", 3/8"** tubing

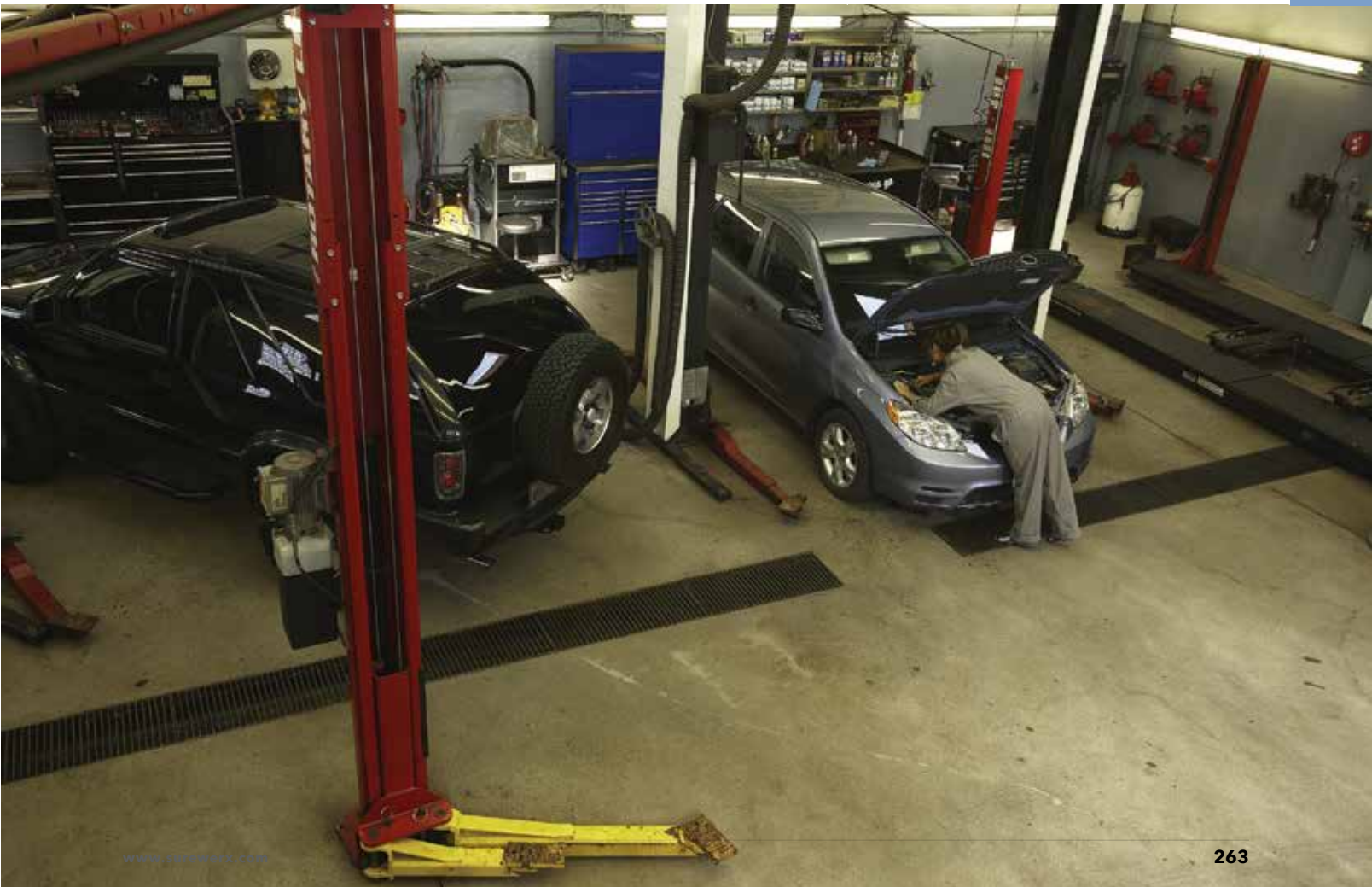

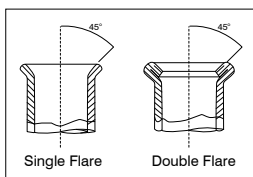

FLARING TOOL KITS

Double Flaring Tool Kit SAE

H1120

- Built to provide the necessary pressure to double flare steel brake tubing
- Will double and single flare both copper and steel tubing
- Double flare adapters provide for 3/16, 1/4, 5/16, 3/8 and 1/2" tubing
- Alloy steel swivel is heat treated, ground, and chromed to reduce compression friction
- Yoke and bar is forged and tempered for added strength

Kit Includes:

H1120A Double flare adapter 3/16"

H1120E Double flare adapter 1/2"

H1120B Double Flare adapter 1/4"

H1120F Bar assembly

H1120C Double Flare adapter 5/16"

H1120G Yoke and bolt assembly

H1120D Double flare adapter 3/8"

H1120H Wingnut

Double Flaring Tool Kit - Metric

H1121

- Built to provide the necessary pressure to double flare steel brake tubing
- Will double and single flare both copper and steel tubing
- Double flare adapters provide for 4.75, 5, 6, 8, 10 mm tubing
- Alloy steel swivel is heat treated, ground, and chromed to reduce compression friction
- Yoke and bar is forged and tempered for added strength

Kit Includes:

H1121A Double flare adapter 4.75 mm

H1121E Double flare adapter 10 mm

H1121B Double flare adapter 5 mm

H1121F Bar assembly

H1121C Double flare adapter 6 mm

H1121G Yoke and bolt assembly

H1121D Double flare adapter 8 mm

H1121H Wingnut

Double Flaring and Cutting Tool Kit

739181 / JTFK-100

- Includes JTC Tubing Cutter, JFT-100 Tool and Double Flaring Inserts for 3/16, 1/4, 5/16, 3/8, 7/16, 1/2 and 5/8" tube
- Provides automotive type double flare or use without inserts for 45° flare
- Cuts up to 1-1/8" (30 mm) tube
- Complete with blow mould storage case
- Replacement Double Flaring Dies:

3/16" - H1120A

7/16" - H1120J

1/4" - H1120B

1/2" - H1120E

5/16" - H1120C

5/8" - H1120K

3/8" - H1120D

ISO Bubble Flaring Tool Kit

H1502

- Front wheel drive cars and light trucks, both foreign and domestic, are installing ISO sized steel brake lines with the ISO flare. This is different from the standard double flare
- Accomplishes the ISO flare without removing the brake line from the vehicle, and it has the strength to withstand the pressure necessary fo flare mild steel tubing (1.0 mm wall thickness) used on the front wheel drive brake line
- Yoke is made of a heat treated, alloy steel drop forging, with a special patented center screw
- Bar assembly is hardened and will hold up under repeated use and produces a smooth, consistent flare
- Kit is complete with flaring tool, four special adapters, a chamfering tool and a combination wrench and height gauge

Kit Includes:

H1502A Adapter 4.75 mm	H1502E Bar assembly
H1502B Adapter 6 mm	H1502F Yoke assembly
H1502C Adapter 8 mm	H1502G Reamer
H1502D Adapter 10 mm	H1502H Wrench

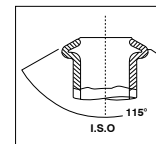

BRAKE REPAIR TOOLS

Deluxe Vacuum Pump with Bleeder Kit

H3502

- Checks vacuum operated components on all vehicles including distributor advance mechanism, heater and air conditioning baffles, PCV and EGR valves, headlight cover doors, transmission modulators and more
- Allows you to bleed brake fluid by yourself
- **Kit Includes:** Fluid resistant valve pump, easy reading gauge head, reservoir jar, transfer and storage lids, rubber cup adapter, two 2' lengths of tube, brake bleeding adapters for most vehicles
- Replacement Parts:

H3502-10 Gauge head	H3502-12 Adapter kit
H3502-11 Bleeder cup and caps	H3502-13 Pump seal kit



11 PC Disc Brake Caliper Tool Set

H3444

- Used to install new rear brake pads by winding the piston back into the caliper
- May be used on or off the vehicle
- Piston retraction is completed smoothly without damaging the piston or boot
- Includes 9 adapters for use on 2 and 4 wheel rear disc brake assemblies
- Designed for use with Mercedes®, BMW®, Volkswagen®, GM®, Audi®, Ford®, Honda®, Subaru®, Mazda®, Nissan®, Mitsubishi®, Toyota®, Land Rover®, and 4 wheel drive vehicles
- Comes in convenient blow mould storage case





CYLINDER HONES – ABRASIVE

Small Brake Cylinder Hone (1/2" – 2-1/2" Range)

H1841



- For sub-compact cars, including imports
 - For cylinder bores 1/2" to 2-1/2" diameter
 - Offers fast, easy cutting with high or low speed drill
 - Self-aligning, self-centering flex joint drive
 - Adjustable tension
- Replacement Stones:
- **H1841A** Set of 2 : Medium, **220 Grit**, Stone Length 1-1/8"

Brake Cylinder Hone (3/4" – 2-1/2" Range)

H1844



- Designed for fast accurate deglazing of cylinders
 - Operated by any 1/4" - 1/2" electric drill
 - Powerful arm design keeps the abrasives accurately in line
 - Spring tension adjusting nut for positive cutting action at all speeds
 - Full range **3/4" - 2-1/2"** capacity equipped with three 220 grit stones recommended for ring seating
- Replacement Stones:
- **H1844B** Set of 3 : Medium, **220 Grit**, Stone Length 1-1/8"

Small Engine Hone (1" – 3" Range)

H1864



- Flexible drive shaft permits easy access to all cylinders
- Cone expansion adjusts hone to cylinder wall with uniform pressure
- Adjustable spring tension to select desired pressure
- Fits standard 1/4" or 3/8" drill
- Range: **1" - 3"** cylinder diameter
- No extensions required
- Supplied with 180 grit 2" stones recommended for quick, positive seating of all piston rings
- Replacement Stone Kit: **H1864C** Set of 3 : **180 Grit**, 2" Long
- Optional Stone Kit: **H1844E** Set of 3 : **220 Grit**, 2" Long

Engine Hone (2 – 7" Range)

H1843



- Designed for fast accurate deglazing of cylinders
 - Operated by any 1/4" - 1/2" electric drill
 - Powerful arm design keeps the abrasives accurately in line
 - Spring tension adjusting nut for positive cutting action at all speeds
 - Full range **2" - 7"** (51-178mm) capacity equipped with three 220 grit stones recommended for ring seating
- Replacement Parts:
- **H1843A** Replacement Stones Set of 3 : Medium, **220 Grit**, 4" Long
- Accessory Stone Sets:
- **H1843E** Set of 3: Coarse, **100 Grit**, 4" Long
 - **H1843F** Set of 3: Fine, **400 Grit**, 4" Long

Wheel Bearing Packer

H3047

- For use with grease guns
- Works on all wheel bearings having a minimum I.D. of 1/2" to a maximum O.D. of 5"
- Height of 1/4" - 2"
- Place bearing between cones and tighten. Old grease is forced out as new grease is pumped in under pressure
- Use hand or power equipment



10 PC Bearing Race and Seal Driver Set

H3437

- Inserts bearing race and seals quickly, straight and without damaging both race and axle housings on the first try
 - Collars fit most standard wheel bearing sizes
 - Comes in convenient blow mould storage case
- Set includes:**
- 9 Disc Sizes: **1.565, 1.750, 1.965, 2.325, 2.470, 2.555, 2.830, 2.995, 3.180"**
 - 1 heavy duty driver handle



18 PC Universal Driver Set

H3538

- Includes most popular size drivers for proper installation of seals, bearings, bushings
 - Ensures even distribution of force to all areas and prevents cocking
 - Comes in convenient blow mould storage case
- Set includes:**
- 12 Drivers: **5/8, 3/4, 7/8, 1, 1-1/8, 1-1/4, 1-3/8, 1-1/2, 1-5/8, 1-3/4, 1-7/8, 2"**
 - 1 handle, 4 cap screws, 1 hex key





FRONT WHEEL DRIVE AXLE NUT TOOLS

7 PC Axle Nut Socket Set

H3533

- Sockets made of high quality Chrome Molybdenum steel for best performance and life
- Sockets are 1/2" drive and are extra long in order to adequately access FWD spindle nuts
- May be used with air and electric impact wrenches, ratchets, flex and breaker bars and with torque wrenches
- Comes in convenient blow mould storage case
- Includes: **29, 30, 32, 34, 35, 36 and 38 mm**

CrMo

Axle Nut Sockets - Open Stock

H3149	29 mm	Serves late model GM*, Ford* and Asian imports including the Escort* and Fiesta*
H3150	30 mm	Serves GM* "A", "J", "N" and "X" body cars and some Asian imports
H3151	32 mm	Serves late model Honda* and Chrysler* cars
H3152	34 mm	Serves late model GM*, Buick*, Cadillac*, Chevy*, Oldsmobile* and Pontiac* cars
H3308	35 mm	Serves many late model GM* cars
H3153	36 mm	Serves GM* "E" style cars
H3309	38 mm	Serves a variety of full size vehicles including many SUV's

TRUCK WHEEL BEARING LOCKNUT SOCKETS

- Specially designed sockets used for the quick and easy removal of truck wheel bearing locknuts
- Made from high quality steel which resists "round out"
- Available in 6 point hexagon, 8 point octagon and special "rounded" shape for Dana® axles
- All sockets are 3/4" drive
- For use with manual ratchets, flex and breaker bars, and torque wrenches

6 Point Hexagon Style

H2150	2-3/32"	H2179	2-7/8"
H2169	2-1/4"	H2155	3"
H2151	2-3/8"	H2157	3-1/4"
H2170	2-1/2"	H2159	3-1/2"
H2171	2-5/8"	H2186	3-3/4"
H2153	2-9/16"	H2161	3-7/8"
H2172	2-3/4"	H2163	4"
		H2164	4-1/8"

Special Rounded Hexagon Style

H2177

- This special "rounded" hex truck wheel bearing locknut socket is used on Dana® axles
- **2-9/16"**

8 Point Octagon Style

H2158	3-1/4"	H2176	3-13/16"	H2166	4-3/8"
H2188	3-3/4"	H2162	3-7/8"	H2168	4-7/8"



Caution: Do not use with any air or electric impact tools

6 Pin 2-5/8" Outer Style Locknut Socket

H1486

- 1978 to current Ford® 3/4 ton vehicles
- 1973 to 1981 GM® 3/4 ton vehicles



4 Pin 2-1/4" Inner Style Locknut Socket

H3406

- 1978 to current 1/2 ton Chevrolet® and GMC®
- 1966 to current Bronco®, Blazer® and Scout®
- 1959 to current Ford® F150-250 series
- 1969 to current Dodge® 1/2 ton vehicles



4 Pin 2-3/4" Outer x 1-9/16" Style Locknut Socket

H3405

- 1985 to late Ford® F250-350 truck rear axle with Hi-Shear rotating nut and Ford® Dana® 80 truck rear axels



3 Step Spindle Remover Tool

H3604

- Pulls out 4WD spindles for lubricating the inner needle bearing and front wheel alignment
- Fits common 1/2 and 3/4 ton 4WD pickup spindles
- 3 step design fits 1-1/2", 1-5/8" and 2" spindles
- Use with 1/2" - 20 or 5/8 thread slide hammer





FOUR WHEEL DRIVE SPINDLE LOCKNUT TOOLS

4 Pin 2-3/8" Outer Style Locknut Socket

H3107

- 1986 to current Ford®, Bronco® and Ranger® with Dana® axles
- 1960 to current 1/2 ton Chevrolet® and GMC®
- 1966 to current Bronco®, Blazer® and Scout®
- 1959 to current Ford® F100-F250 series
- 1969 to current Dodge® 1/2 ton vehicles

4 Pin Toyota® Style Locknut Socket

H3601

- Toyota® 1995 and newer Tacoma, 1996 and newer T100 and 4-Runner

4 Pin 1-1/2" Inner Style Locknut Socket

H3407

- Used on 1/2 and 1 ton 4WD vehicles

FRONT END SERVICE TOOLS

5 PC Front End Service Kit

H3540

- Complete front end service tool kit for easy removal of most pitman arms, tie rods and ball joints
- Includes a press type separator for ball joint removal without damage to boots and other parts
- An absolute must for all front end service shops
- Comes in convenient blow mould storage case

Kit includes:

- **H1926** Pitman Arm/Tie Rod End Puller
- **H3609** Pitman Arm Puller
- **H3612** Tie Rod/Inner Bearing Race Puller
- **H3614** Ball Joint Separator
- **H3616** Ball Joint/Tie Rod End Remover

5 PC Pickle Fork Kit**H3448**

- A multi-purpose kit that features all the tools required to separate most ball joints, tie rods, pitman arms and shock absorber links
- 3 heavy duty forks are made from drop forged, heat treated steel
- 2 drive handles are made from alloy steel - one handle for use with regular hammers, the other features a .401 shank for use with most popular air hammers
- Forks can be used with either drive handle
- Pilot head designed handles absorb shock and protect threads from distortion

Kit includes:

- Tie Rod Separator Opening **11/16"**
- Ball Joint Separator Opening **15/16"**
- Pitman Arm Separator Opening **1-1/8"**
- Alloy Handle - for use with regular hammers length 8"

**Pitman Arm Puller – Heavy Duty****H3609**

- Specially designed jaws fit the job and ensures firm grip
- Extra wide opening of **1-3/8"**
- Pull **3-1/2"**

**Pitman Arm/Tie Rod End Puller****H1926**

- For use on small cars having smaller pitman arms and tie rod ends
- Can also be used for rack and pinion steering removal
- Opening: **1-1/16"**
- Pull: **1-3/4"**

**Ball Joint/Tie Rod Remover****H3612**

- Swivel centering pin ensures a strong, positive pull
- Tool directly attaches to stud for easy and convenient use
- Fits most front wheel drive vehicles and light trucks
- Opening: **3/4"**
- Pull: **1-1/2"**

**Ball Joint Separator - Universal Application****H3614**

- Heavy duty "scissor" design suits most cars and light trucks
- Easily separates press fit ball joints
- 2-stage height adjustment feature uses a heat treated steel pin thrust bolt and steel ball insert, allowing quick and easy height adjustment changes
- The combination of the "scissor" design and the 2-stage height adjustment offers maximum versatility
- Can be used on most press fit ball joint applications



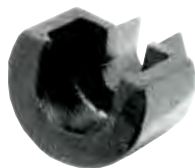

FRONT END SERVICE TOOLS

Dual Socket Inner Tie Rod Tool

H3060

- Features a double ended "stepped" socket
- **1-3/16" hex** fits primarily Ford® (FWD) and Renault®
- **1-5/16" hex** fits primarily GM®, AMC®, Chrysler® and Ford® (RWD)
- 1/2" Square Drive

4 PC Inner Tie Rod Removal Kit

H3061

- The tool kit contains everything necessary to directly remove and install the inner tie rod without the hassles of removing the steering gear
- Works on most inner tie rod structures
- Made of heavy duty alloy steel, black oxide finish
- Comes in convenient blow mould storage case

Dual Inner Tie Rod Adapter For H3060/H3061 (1-7/16")

H3071

- **1-7/16" adapter** for GM® and Chrysler® cars with Saginaw® steering gear
- Use with H3060 Dual Inner Tie Rod Tool

H3071A

1-3/16" Adapter for H3060 and H3061

H3071B

1-5/16" Adapter for H3060 and H3061

Ball Joint Separator (15/16" Opening)

H1902

- Removes ball joints from connecting links
- Just a few sharp blows with a hammer and the tapered prongs easily separate the parts
- Opening: **15/16"**
- Length: **12"**

Tie Rod End Separator (21/32" Opening)

H1907

- Removes tie rod ends from connecting links
- Just a few sharp blow with a hammer and the tapered prongs easily separate the parts
- Opening: **21/32"**
- Overall Length: **16"**

Outer Tie Rod Remover

H3616

- The adjustable jaw can spread to match tie rods of various sizes
- Removes the outer tie rod from the steering knuckle
- The custom designed jaw tips ensure maximum grip and withstands up to 5 tons of pulling force!
- The use of this mechanical screw puller ensures an evenly distributed pulling force, eliminating damage to existing parts
- Ideal for use on import and domestic cars with front and rear wheel drives with stamped or cast steel steering knuckles
- Opening: **0 to about 7"**
- Pull: **4"**

Ball Joint Master Service Kit

H3536

- This master kit covers most press-fit vehicle joint components
- Used to service the removal/installation of ball joints, universal joints, truck brake anchor pins and 4WD ball joints
- C-frame alone can be used to remove/replace universal joints
- Tool can remove rusted and corroded parts
- Comes in convenient blow mould storage case

Kit includes:

- Heavy duty C-frame and forcing screw (1.106" x 7 threads per inch)
- Receiver tubes and receiving/installation adapters to work on press fit upper and lower ball joints on most Dodge® Ram, Ford®, GM®, IHC® and Jeep® 2 and 4 wheel drive pick-up trucks, SUV's and vans (autos with Dana® front axles)

**MacPherson® Strut Coil Spring Compressor Kit**

H1560

- Allows you to quickly compress the coil spring to replace shock absorbers, spring sets, repair bent strut or strut tube and repair damaged spindle
- Designed to be used on virtually all modern domestic and imported vehicles that use MacPherson® struts
- Do not use on GM® "A", "J", or "X" body cars or coil springs that exceed a 6" outside diameter

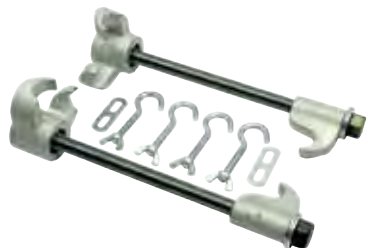
**C.V. Boot Clamp Pliers - Earless**

H1084

- For earless type clamps
- Ratchet will lock for easy use

**Ball Joint 4-in-1 Service Kit**

H3537

- For press-fit vehicle joint components
- Heavy duty, four function kit to service the removal/installation of ball joints, universal joints, truck brake anchor pins and 4WD ball joints
- Both ball joint and 4WD ball joint service can be done without taking the control arm off
- U-joint service can be performed on needle type U-joint bearings
- Truck anchor pin service can be performed with pins up to 1-1/4" diameter
- Services 4WD ball joint equipped vehicles including those vehicles with Dana® 44 front axles such as 1967 to current 1/2 ton and 3/4 ton Dodge®, GM®, Ford®, IHC®, Jeep®
- Tool will even remove rusted and corroded parts
- C-frame alone can be used to remove/replace universal joints
- Comes in convenient blow mould storage case

Kit Includes:

- Heavy Duty C-frame and forcing screw (1.106" x 7 threads per inch)
- Installation and removal adapters
- Installation cup adapter
- Receiving and installation cups
- 3 Receiver tubes: 2-3/4" x 2-1/4", 2-1/4" x 1-3/4", 1-3/4" x 1-3/4"

**MacPherson® Strut Deluxe Coil Spring Compressor Kit**

H3315

- Built-in detent pins to help lock the coil in place eliminating the need for extra safety hooks. Set up is faster and easier
- Comes in convenient blow mould storage case

**C.V. Boot Clamp Pliers - Eared**

H1088

- For eared type clamps
- Unique design allows user to clamp ring and then use a torque wrench in 1/2" square drive holes in handle to accurately set clamp
- Plunger can be deactivated





1/4" Drive Flexible Radiator Hose Clamp Driver

H3319

- Multi-use, flexible-shaft, 1/4" drive socket driver
- 12" Overall length shaft will tighten or loosen hex head screws on gear type hose clamps and other applications in even the most hard to get at places
- 1/4" drive end allows operator to attach any 1/4" drive socket to fit the job



Hose Clamp Pliers - Flexible Flat Band Type

H3290

- Designed to access the flat-type hose clamps located in hard-to-reach areas
- Pliers have locking mechanism to hold clamp in the open position - for easy removal and installation of clamp
- Spring loaded handles
- Heavy-duty 24" cable flexes to almost any position
- Range: **0-2-1/16" (0-53 mm)**
- Length: **33"**
- Replacement Part: **H3290-10** Cable Assembly



3 PC Hose Pinch-Off Pliers Set

H3318

- For use on all brake and fuel hose lines
- Special rounded edges ensure no damage to lines or internal reinforcements
- Lightweight and non-conductive
- Three sizes for use on most jobs

Set includes:

- **H3140** Capacity **1/4" - 7/16" (6 - 12 mm)**
- **H3316** Capacity **1/2" - 3/4" (13 - 19 mm)**
- **H3317** Capacity **3/4" - 2-1/4" (19 - 57 mm)**

Small Hose Pinch Off Pliers (1" Capacity)

H3128

- No need to drain system when changing thermostats. Save coolant - save time
- Heat treated jaws swivel for parallel clamping
- Steel arms automatically lock with ratchet
- May also be used to pinch off vacuum lines
- Overall Length: **10"**
- Capacity: **Up to 1"**
- Note: Not for use on wire reinforced radiator hose



Small Hose Pinch Off Pliers (1-3/8" Capacity)

H3129

- No need to drain system when changing thermostats. Save coolant - save time
- Heat treated jaws swivel for parallel clamping
- Steel arms automatically lock with ratchet
- May also be used to pinch off vacuum lines
- Overall Length: **12"**
- Capacity: **Up to 1-3/8"**
- Squeezes wire reinforced radiator hose



DRIVE BELT TOOLS

14 PC Deluxe Serpentine Belt Tool Kit

H3529

- Enables rapid and easy removal and installation of belts on serpentine belt equipped vehicles
- Connect the tool to the spring loaded idler pulley to release the tension
- Fits most vehicles

Kit includes:

- Serpentine belt tool with cushion grip
- Extension Bars: **6"** and **10"** - for versatility and leverage
- Sockets: **13, 14, 15, 16, 18 mm** - with custom 16 mm drive end to fit bars
- 3/8" and 1/2" Drive adapters - with custom 16 mm drive end to fit bar
- 3/8" Drive Crowfoot Wrenches **13, 14, 15 mm** - use with 3/8" adapter above
- 3/8" - 16 UNC Bolt - to attach extension bars to long handle
- Comes in convenient blow mould storage case





FAN CLUTCH WRENCHES

10 PC Fan Clutch / Water Pump Wrench Kit

H3530

- Removes and installs fan clutches and water pumps on most Chrysler®, Ford® and GM® vehicles
- Holding wrench immobilizes the fan clutch. The nut wrench turns the nut on or off
- Works in tight spaces where conventional wrenches won't reach
- Heat-treated for strength and durability
- Use with 1/2" drive ratchet or breaker bar for more torque

Kit includes:

- Fan Pulley Holding Tool: **2-1/4"** and **3-1/4"**
- Fan Clutch Bolt Holding Tool: **2-3/8"**
- Fan Clutch Pulley Holding Tool: **2-1/8"** and **3"**
- Fan Clutch Nut Wrench: **1-7/16"**
- Fan Clutch Wrench: **1-7/16"** and **1-9/16"**
- Fan Hub Wrench: **2-13/16"**
- Clutch Nut Wrench (left hand): **1-7/8"**
- Comes in convenient blow mould storage case



4 PC Fan Clutch Wrench Kit

H3531

- Designed for removing and installing fan clutch assemblies on most Ford® engines
- Holding wrench immobilizes the fan clutch. The nut wrench turns the nut on or off
- Works in tight spaces where conventional wrenches won't reach
- Heat treated for strength and durability
- Use with 1/2" drive ratchet or breaker bar for more torque
- The small double-ended wrnech is for 2.8, 2.9, 3.0, 4.0 and 4.9 litre engines
- The large single-ended wrenches and large holding wrnech are for 6.9 and 7.3 litre diesel engines

Kit includes:

- Double-ended Fan Clutch Wrench: **36mm and 1-9/16"**
- Fan Clutch Holding Wrench: **58mm**
- Fan Clutch Holding Wrench: **1-7/8"**
- Fan Clutch Holding Wrench: **3-1/4"**
- Comes in convenient blow mould storage case

Compression Tester Gas Engines

H1730

- Quick disconnect flexible hose
- This quality, accurate tester has an angle construction tip to permit easy reading on back cylinders
- The most popular type in use today
- The heavy duty neoprene hose bends in all directions for hard-to-reach cylinders



H1730

Compression Tester Gas Engines

H1731

- Same features as H1730 without quick disconnect flexible hose
- Handy side release valve allows multiple readings on the same cylinder without removing the tester from the cylinder
- Hose assembly will disconnect easily from the gauge head to allow more flexibility and easier installation into spark plug holes



H1731

Accessories - Replacement Parts

H1730B	Quick Coupler - H1730
H1730C	Hose Assembly Fits - H1730/H1731
H1730D	Long 14 mm Adapter - H1730/H1731
H1730E	10 mm Adapter - H1730/H1731
H1730F	12 mm Adapter - H1730/H1731
H1730H	16 mm Adapter - H1730/H1731

Cylinder Leak Down Tester

H3042

- Tests for worn or broken rings, defective intake and exhaust valves, scored or cracked cylinders, leaky head gaskets and worn or stripped spark plug threads by measuring the amount of compressed air held in an engine cylinder
- Easy to use on all 2 and 4 cycle gasoline and diesel engines
- Dual gauges allow you to monitor input air line pressure up to 100 PSI
- Unit has precision pressure regulator to adjust pressure in cylinder to "set" area on regulator gauge
- Regulator gauge will read percentage of leak down in cylinder while the input pressure gauge assures that input pressure is steady



H3042

Replacement Parts

H3042A	Gauge Head - H3042
H3042B	Regulator - H3042
H3042C	Leakage Gauge - H3042
H3042D	11-1/4" Hose Assembly with 14 and 18mm Adapters
H3042K	Diesel Hose Adapter for H3042

Accessories

H1730E	10 mm Adapter - H1730/H1731
H1730F	12 mm Adapter - H1730/H1731
H1730H	16 mm Adapter - H1730/H1731

Compression Tester for Diesel Engines

H1845

- For most diesel trucks and cars
- Supplied with three popular adapter numbers **H1845D, H1845E and H1845J**
- Easy-to-read 2-1/2" diameter gauge head
- Flex hose with swivel head eliminates the need to remove auxiliary equipment such as power brakes and steering, air conditioning and manifold
- Quick side release valve to reset gauge without removal of adapter
- Gauge Range: 0 - 1,000 PSI, 0 - 70 kg/cm²

Adapters Available:

- Listed by vehicle make
- See illustrations

Replacement Parts:

- **H1845A** Hose Assembly 24-1/4"
- **H1845B** Gauge Head
- **H1845C** Quick Coupler
- **H1845G** Valve Core



Accessories - Adapters - Replacement Parts - H1845 Diesel Tester

Manufacturer	Engine	Type	Thread (in)	Adapter
Allis Chalmers	6000, 7000, 10,000, 11,000	Injector		H1845P
Allix		Injector		H1845P
Audi	All	Injector	24 x 2.0	H1845E*
Audi	1.5, 1.6, 2.0, 2.6 LITRE	Glow Plug	12 x 1.25	H1845H
BedFord™	200, 220, 300, 330, 466	Injector		H1845P
BMW	2.4L	Glow Plug	12 x 1.25	H1845H
Case		Injector		H1845P
Caterpillar	3208, 110 Pencil Type	Injector		H1845FF
Caterpillar	D336, 1674, 1676,	Injector	7/8 x 14	H1845GG
Caterpillar	3406, 3408, 3412	Injector	7/8 x 14	H1845GG
Continental	W/Volvo Engines	Glow Plug	10 x 1.25	H1845M
Cummins	V-185, V-210, V225	Injector		H1845Q
Cummins	V-555, VT-255, VT-555	Injector		H1845Q
Cummins	H, HR, NH, NVH, V6, V8,	Injector		H1845Q
Cummins	V12, All 5.5 Bore	Injector		H1845Q
Cummins	NH and 903 V8 Cylindrical PTB	Injector		H1845Q
Cummins / Case "B"	2.9L, 3.9L, 5.9L	Injector	24 x 1.5	H1845Y
Cummins / Case "C"	8.3L	Injector		H1845DD
Datsun		Injector	24 x 2.0	H1845N
Detroit Diesel	53, 71, 92, 110, 149, V53, V71	Injector		H1845R
Dodge / Cummins	5.9L	Injector	24 x 1.5	H1845Y
Dodge / Cummins	Late model 5.9L ISB & QSB 24 valve	Injector		H1845-3
Flat Allis	8035-02-300, 8035-02-301	Injector		H1845P
Flat Allis	8035-02-302, 8045-02, 8045-03	Injector		H1845P
Ford™	2.0L	Glow Plug	10 x 1.25	H1845M
Ford™ / Escort		Glow Plug	10 x 1.25	H1845M
Ford™ / Lynx		Glow Plug	10 x 1.25	H1845M
Ford™ / Mazda	2.0L	Glow Plug	10 x 1.25	H1845M
Ford™ / Navistar	6.9, 7.3L	Glow Plug	10 x 1.0	H1845D*
Ford™ / Navistar	7.3L Turbo Diesel	Glow Plug	10 x 1.0	H1845KK
Ford™ / Navistar	7.3L Turbo Diesel	Glow Plug	10 x 1.0	H1845-2
Ford™ / Powerstroke	6.0L, 6.4L	Glow Plug	14 x 1.25	H1845-4
Ford™ Ranger	2.2L	Glow Plug	10 x 1.25	H1845M
Ford™ Tempo		Glow Plug	10 x 1.25	H1845M
Ford™ Topaz		Glow Plug	10 x 1.25	H1845M
Ford™ Toyo Kogyo	2.2L	Glow Plug	10 x 1.25	H1845L
Ford™ Tractors	21mm Bosch	Injector		H1845P
Ford™ / Mazda	2.0L	Glow Plug	10 x 1.25	H1845L
General Motors	4.3L V6 & V8, 5.7L V8	Glow Plug	10 x 1.0	H1845D*
General Motors	6.2L & 6.5L V8 True Diesel	Glow Plug	10 x 1.0	H1845J*
GMC® Truck	W4, W7, W7HV	Glow Plug	12 x 1.25	H1845H
GMC® Truck	6.6L	Glow Plug	10 x 1.25	H1845K
Hino	Medium	Glow Plug	12 x 1.25	H1845H
Int'l Harvester	6.9 L	Glow Plug	10 x 1.0	H1845D*
Int'l Harvester	D/DT361, D/DT429, DV462	Injector		H1845P
Int'l Harvester	DV/DVT550, DT/DV/DVT573	Injector		H1845P
Int'l Harvester	361, 407	Injector		H1845P
Isuzu Chevette	1.8L	Glow Plug	10 x 1.25	H1845K
Isuzu GM	1.8L, 2.2L	Glow Plug	10 x 1.25	H1845K
Isuzu/Luv	2.2L	Glow Plug	10 x 1.25	H1845K
Isuzu Truck	NPR, KS	Glow Plug	12 x 1.25	H1845H
J.I. Case	All Models Except Pencil Type	Injector		H1845P
J.I. Case	188, 207, CID, Pencil Nozzle	Injector		H1845FF



H1845D



H1845F



H1845J



H1845N



H1845V



H1845DD



H1845FF



H1845K

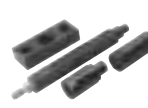

H1845P



H1845W



H1845E



H1845GG



H1845KK



H1845Q

Manufacturer	Engine	Type	Thread (in)	Adapter
John Deere	Early 300, 400, 500 276	Injector		H1845FF
John Deere	Early 404, 532 CID	Injector		H1845FF
John Deere	404, 466, 531, 619	Injector		H1845P
Kubota	Some models	Glow Plug	10 x 1.25	H1845M
Kubota	Some models	Glow Plug	8 x 1.0	H1845-5
Land Rover		Glow Plug	14 x 1.25	H1845V
Lealand British		Glow Plug	14 x 1.25	H1845V
Lincoln, Mark VII	2.4L 1984 & 1985 cars	Glow Plug	12 x 1.25	H1845H
Mack Truck		Injector		H1845P
Mack Truck	END 405, 457, 475, 510, 519	Injector		H1845P
Mack Truck	605, 672, 673, 674, 711, 864	Injector		H1845P
Mack Truck	END T673, 675, 676, 865, 866	Injector		H1845P
Massey Ferguson		Injector		H1845P
Massey Ferguson	4.203, 4.236, 4.248, 6.354, 8.540	Injector		H1845P
Mercedes	All with 24mm	Injector	24 x 2.0	H1845E*
Mercedes	All with 12mm	Glow Plug	12 x 1.25	H1845H
Mercedes	All with 18mm	Glow Plug	18 x 1.5	H1845F
Mercedes	All with 22mm	Injector	22 x 1.5	H1845HH
Mitsubishi	2 & 3 cylinder engines	Glow Plug	10 x 1.25	H1845M
Mitsubishi-Fuso	Medium	Glow Plug	10 x 1.25	H1845M
Mitsubishi-Fuso	Medium	Injector		H1845P
Navistar	DT360, DT466, 9.0L	Injector		H1845EE
Navistar	312, 360, 414, 436, and 466 C.I.D.	Injector		H1845EE
Navistar	6.9L, 7.3L	Glow Plug	10 x 1.0	H1845D*
Nissan	2.2L	Glow Plug	10 x 1.25	H1845M
Onan	DSL, MDSL	Injector		H1845P
Opel		Injector	22 x 1.5	H1845X
Peugeot	All 2.0 & 2.3L	Glow Plug	12 x 1.25	H1845H
Peugeot		Glow Plug	18 x 1.5	H1845F
Renault		Injector	24 x 2.0	H1845W
Renault		Injector	22 x 1.5	H1845X
Scania	DN11 & DS11	Injector		H1845P
Toyo Kogyo	2.2L	Glow Plug	10 x 1.25	H1845M
Toyota	1.8L	Glow Plug	10 x 1.25	H1845K
Toyota	2.2L	Glow Plug	10 x 1.25	H1845M
UD-Nissan Truck	Medium	Glow Plug	10 x 1.25	H1845M
Volvo	All	Injector	24 x 2.0	H1845E*
Volvo		Glow Plug	12 x 1.25	H1845H
VW	All	Injector	24 x 2.0	H1845E
VW		Glow Plug	10 x 1.0	H1845Z
VW		Glow Plug	12 x 1.25	H1845H
Waukesha	All	Injector		H1845P
White Farm	66, 77, 88, 99, 166, 177, 188, 199	Injector		H1845P
White Farm	550, 660, 770, 880, 950, 1550	Injector		H1845P
White Farm	1555, 1600, 1650, 1655, 1750	Injector		H1845P
White Farm	1755, 1800, D2000, 2300, 3000	Injector		H1845P
Wisconsin	340, 350, 430, 660, 670, 750	Injector		H1845P
Wisconsin	860, 1000	Injector		H1845P



H1845X



H1845EE



H1845H



H1845L



H1845R



H1845Y



H1845ET



H1845HH



H1845M



H1845S



H1845Z



H1845-2



H1845-3



H1845-4

For applications not listed above: H1845S - 1/8" N.P.T. Male Quick Coupler.

This adapter along with 1- H1845G Valve Core (thread size 12-36) can be used to make your required adapter for engines not listed above. Remove internal mechanism from an old injector or glow plug from that engine, drill and tap to accept the quick coupler and valve core.

*Included in Kit



COMPRESSION AND PRESSURE TESTERS

Vacuum and Pressure Tester

H1728

- 2-1/2" Chrome plated vacuum tester aids diagnosis of engine problems such as sticky valves, timing, carburetion, faulty fuel pump, and other vacuum-operated devices
- Brass adapter fitting provided
- Pressure Range: **0 - 15 PSI, 0 - 1 kg/cm**
- Vacuum Range: **0 - 30 in, 0 - 76 cm HG**

Replacement Parts:

- **H1728A** Gauge Head

CAUTION: Do not use on fuel injected vehicles

Oil Pressure Tester

H3041

- Check oil pressure in automatic transmissions and engines
- Adapters used on most domestic and imported cars and light trucks including late models
- Supplied with two gauges:
 - High Pressure Gauge - Calibrated from **0 - 300 PSI, (0 - 21.0 kg/cm²)**
 - Low Pressure Gauge - Calibrated from **0 - 100 PSI, (0 - 7.0 kg/cm²)**
- Use high pressure gauge for all applications
- Use low pressure gauge for more accurate reading of engine oil pressure where maximum oil pressure does not exceed 100 PSI (7.0 kg/sq.cm)
- Comes in a durable vinyl pouch
- Full instructions provided
- **Note:** Do not use low pressure gauge to test automatic transmission pressure

Replacement Parts:

- **H1734X** gauge head (H1730, H1731, H3041)
- **H3041B** gauge head 100 PSI
- **H3041C** hose assembly (6' oil proof hose)
- **H3041D** 11 piece adapter kit
 - 1 ea. Bushing, 3/8" NPT Male
 - 1 ea. Bushing, 1/4" NPT Male
 - 2 ea. 90 degree elbow 1/8" M to F
 - 1 ea. 1/8" M to 1/4" M adapter
 - 1 ea. 1/8" F to 1/8" F Coupling
 - 1 ea. 2" extension, 1/8" M to 1/8" M
 - 1 ea. 10 mm adapter
 - 1 ea. 1/8" BSP adapter
 - 2 ea. 8mm adapter

Piston Ring Compressor Kit - Ring-O-Matic Series H1670

- Quick change design speeds piston ring installation and increases production
- The Ring-O-Matic pliers and bands are designed to operate in all positions, not just vertically or horizontally
- Pliers incorporates precision locking action for exact holding and quick release

Kit Includes:

- **H1670A** Ring-O-Matic Pliers
- **H1670B** for Pistons **2-7/8" - 3-1/8"**
- **H1670C** for Pistons **3-1/8" - 3-3/8"**
- **H1670D** for Pistons **3-3/8" - 3-5/8"**
- **H1670E** for Pistons **3-5/8" - 3-7/8"**
- **H1670F** for Pistons **3-7/8" - 4-1/8"**
- **H1670G** for Pistons **4-1/8" - 4-3/8"**

Larger bands available:

- **H1670H** for Pistons **4-1/2" - 4-3/4"**
- **H1670I** for Pistons **4-3/4" - 5"**
- **H1670J** for Pistons **5" - 5-1/4"**
- **H1670K** for Pistons **5-1/4" - 5-1/2"**
- **H1670L** for Pistons **5-1/2" - 5-3/4"**
- **H1670M** for Pistons **5-3/4" - 6"**



HEAD AND VALVE REPAIR TOOLS

Deluxe Overhead Valve Spring Compressor H3456

- Designed to service most cars with overhead valves and newer vehicles with confined areas under the hood
- The knob is removable exposing a 5/8" hex post allowing the technician to operate the tool with a 5/8" wrench or socket
- The components are heat treated for added strength and long service life
- Not to be used with impact tools
- Use on or off the car



Valve Spring Compressor H3183

- Vertical lift design
- Equipped for 1" - 2" spring diameters. Height: 10" Width: 8"
- Prevents bending of valve stem. Sure, one hand control lock and release is powerful enough to compress the strongest spring with ease
- Quickly adjusts for any valve stem length. One simple adjustment with the pin-operated screw on the first set of valves sets clamp for the balance of springs.
- Replacement Jaws (included with tool): H3183A Straight Jaw (pair), H3183B Offset Jaw (pair)
- Optional Jaws: H3183C Extra High Offset Jaw





H1183



H1185



VALVE LAPPING TOOLS

Rubber Cup Valve Lapping Sticks

- For precision hand grinding valves and seats
- Synthetic rubber cup is resistant to oil, gasoline and grinding compounds
- Comfortable wooden handle. A must for that final valve seat fitting operation

PROD. NO.

Cup

H1183

3/4"

H1185

1-3/16" and 1-5/16"

TUNE-UP TOOLS

Ignition Point and Machine File

H1866

- Double cut ignition files made from high quality steel with Rockwell Hardness of 65
- Easily cuts tungsten or platinum contact points
- Use on ignition points, spark plugs, relays, circuit breakers and much more
- 2 per package

In-Line Ignition Spark Tester

H3143

- Connects in-line between spark plug and spark plug wire
- Shows a duplicate view of the ignition spark
- Technician can visually check condition of each cylinder
- Frequency and intensity of flash pattern indicates whether there is an ignition or fuel delivery system problem. Flash can be seen in bright sunlight
- Clear plastic body can withstand rough use and resists automotive chemicals
- Flexible wire protected by mechanical strain relief
- Instructions included

Spark Plug Boot Pliers - Angled Jaws

H3295

- Designed to protect against plug wire and boot separation.
- Handle and jaws are vinyl coated to insure complete insulation and non slip grip
- Overall length: **9-3/4"**

Mechanic's Stethoscope

H1262

- This sensitive instrument provides a fast and accurate method of locating problem in engines and other moving parts
- Earphones block outside noises
- Plastic handle protects user from shock

Muffler Expanders

- Use with impact wrench
- Removes clamp grooves and rounds out exhaust pipes
- A practical, rugged tool that makes easy work for a tough job
- Expansion rings set in deep grooves to prevent wear

CAUTION: Not to be used to stretch pipes

Pipe & Muffler Expander - Standard

H1017

- For Passenger Cars

Pipe & Muffler Expander - Small

H1175

- For Compacts & Foreign Cars

Pipe & Muffler Expander - Extra Large

H1176

- For Passenger Cars & Trucks

Exhaust System



H1017 / H1175



H1176

PRESSURE TESTERS

- Unique design allows pressure to be taken either through the oxygen sensor hole or through the exhaust pipe with a threaded insert system (included)
- Accurately determines excessive exhaust back pressure caused by catalytic converter or muffler blockage

Exhaust Pressure Tester

H3148

Kit Includes:

- **H3148A** Gauge: 0 - 15 lb
- **H3148B** Hose Assembly
- **H3148C** Insert Installing Tool
- **H3148D** Oxygen Sensor Adapter 18mm
- **H3148E** Oxygen Sensor Adapter 12mm
- **H3148F** 10 Pack: Inserts, Washers, Screws



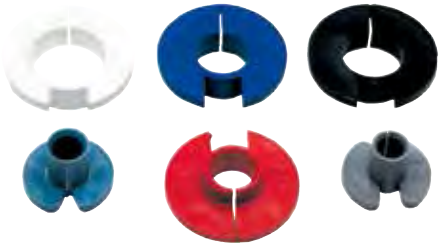

FLUID LINE TOOLS

6 PC Disconnect Tool Set

H3501

- Easily disconnect spring lock couplings on Ford® and Chrysler® air conditioning lines
- Use on fuel line quick connect couplings found on late model GM®, Ford®, and Chrysler®
- Can be used on Ford® transmission and radiator cooler lines
- Set contains six colour coded tools that are stamped with size for quick identification
- Sizes: SAE **5/16", 3/8", 1/2", 5/8", 3/4", 7/8"**
Metric **8, 9, 13, 16, 19, 22 mm**

11 PC Master Disconnect Tool Set

H3544

- This master fuel line quick disconnect tool set broadens the applications of disconnecting fittings and spring lock couplings on fuel, filter cooler and transmission oil lines
- Fuel line disconnects are colour coded anodized aluminum for easy identification
- A must for all mechanical service shops
- Use with most vehicles on the market today
- Comes in convenient blow mould storage case

Disconnect Tool Set for Fuel and Air Conditioning Lines

H3089

- This spring-lock coupling release tool easily separates fittings on fuel and air conditioning lines
- Sizes: **3/8", 1/2", 5/8"** and **3/4"**

Disconnect Tool for Fuel Lines

H3351

- This spring-lock coupling release tool easily separates fittings on fuel lines
- Sizes: **3/8"** and **5/16"**

Disconnect Tool for GM® Heater Lines

H3364

- Releases heater line quick connect fitting from engine block and thermostat housing
- 1991 - current GM® 3.1L / 3.4L and 3800 engines

Disconnect Tool for Ford® Fuel Lines

H3352

- 1990 - current Ford® Ranger® and Explorer with 4.0 Litre, 6 cylinder engines

Disconnect Tool for Ford® / GM® CFI Fuel Lines

H3353

- Ford® CFI fuel lines with hair pin connectors
- Universal for radiator to transmission oil cooler lines
- 1987 and later model Olds Toronado; Buick Riviera® and Reatta®; Cadillac Eldorado®, Seville® and Concours®; 1989 and later Model GM® 1/2, 3/4 and 1 Ton pickups

2 PC Disconnect Tool Kit for Fuel, Transmission and Oil Cooler Lines

H3354

- Separates quick connect fittings from transmission, radiator oil cooler and power steering lines

Kit Includes:

- Ford®/GM® quick disconnect coupler tool and Ford® oil cooler line disconnect tool

Applications:

- Ford® EFI fuel lines with hair pin connectors
- Transmission/oil cooler lines on 1989 - current/GM® 1/2, 3/4 and 1 Ton pickups; 1986 - current Ford® Taurus and Mercury Sable with AXOD, AOD, or ATX transmissions

Disconnect Tool for Ford® Oil Cooler Lines

H3355

- Ford® vehicles with AXOD, AOD, or ATX transmission

1/4" Disconnect Tool for Fuel Lines

H3356

- 1995 - 1996 Ford® Mustang 1/4" fuel pump return line

5/16" Disconnect Tool for Fuel Lines

H3357

- 1990 - current Ford® Aerostar, Explorer, Bronco® with 5/16" fuel lines
- 1991 - current Ford® E and F series trucks with 5/16" fuel lines
- 1992 - current Ford® Ranger® with 5/16" fuel lines
- 1992 - current GM® with 5/16" fuel lines

3/8" Disconnect Tool for Fuel Lines

H3358

- 1990 - current Ford® Aerostar, Explorer, Bronco® with 3/8" fuel lines
- 1991 - current Ford® E and F series trucks with 3/8" fuel lines
- 1992 - current Ford® Ranger® with 3/8" fuel lines
- 1994 - 1997 Dodge® Ram V6 and V8 trucks with 3/8" cooler lines
- 1995 - 1996 Dodge® Ram Van/Wagon with 3/8" cooler lines

Disconnect Tool for Ford® Oil Cooler Lines

H3359

- Ford Taurus® and Escort® oil cooler lines on AXOD or ATX transmission



Caution: release system pressure before using these tools!

40 PC Master Fuel Injection Test Kit**H2000**

- Contains all items necessary for checking the fuel injection systems on most domestic and foreign vehicles
- Features a large, **3-1/2" gauge** head with dual readings of **0 - 145 PSI** and **0 - 1,000 kPa**, and **2-1/2" gauge** with dual readings of **0 - 15 PSI** and **0 - 100 kPa**
- All adapters, gauge heads, and hose assemblies feature a quick coupling system
- Comes complete with instructions in a blow moulded carrying case
- Case will accommodate H2000UPA Supplement Kit

Parts and Accessories for Test Kits H2000/H2002**Gauges and Hoses**

H2000A	3-1/2" Gauge Head with dual readings 0-145 PSI and 0-1000 KPA (10 Bar) Can be used for all tests
H2000AA	Low pressure 2-1/2" Gauge with dual readings 0-15 PSI and 0-1kg/cm ² (1 Bar) Use for tests where an accurate reading below 15 PSI is required
H2000AB	Quick Coupler
H2000D	Gauge Hose Assembly with blow-down valve
H2000G	CIS/TBI Test Hose
H2000DX	72" Extension Hose
H2000RK	Repair Kit, O-Rings, Washers

Test Port Adapters

H2000B	Large Schrader Type Test Hose with 7/16" x 20 thread
H2000BK	Replacement Washer and Pin for H2000B
H2000B90	Large Schrader 90° Adapter
H2000C	Small Schrader Type Test Hose with .308 x 32 thread
H2000C90	Small Schrader 90° Adapter

In-Line Testing TBI

H2000S	Union 5/8" x 18
H2000T	16 mm x 1.5 Female Tube Nut (2)
H2000U	16 mm x 1.5 Male Tube Nut (2)
H2000UA	14 mm x 1.5 Female Tube Nut (2)
H2000UB	14 mm x 1.5 Male Tube Nut (2)
H2000UC	14 mm x 1.5 Plug
H2000UPA	
H2000V	5/8" x 18" Male Fitting (2)

In-Line Testing - Special Connections

H2000F	Double-ended Hose Fitting 5/16" - 3/8"
H2000W	Spring Lock Hose - Common Application Ford® CFI
H2000X	Hair Pin Hose 5/16" - Common Application Ford® EFI
H2000XA	Hair Pin Hose 3/8" - Common Application GM®, Chrysler®

Multi-Port Injection Pressure Tester**H2002**

- Test fuel pump pressure on most domestic and import vehicles equipped with multi-port fuel injection systems using the small or large Schrader type connection
- Can be used on most import vehicles, except those equipped with Bosch C.I.S
- Includes bleed-off valve with hose to safely enable technician to depressurize fuel system after testing
- **3-1/2" gauge** diameter has dual scale: **145 PSI/1,000 kPa**
- Full instructions included
- Supplied in vinyl storage pouch

**End of Line, Banjo - Fuel Bolt Adapters**

H2000E	Single End Hose Connection - 1/4" x 3/8"
H2000N	6 mm x 1.0 Thread
H2000NN	8 mm x 1.0 Thread
H2000P	10 mm x 1.0 Thread
H2000Q	12 mm x 1.25 Thread
H2000R	12 mm x 1.5 Thread
H2000RA	14 mm x 1.5 Thread

In-Line Testing CIS, CISE and K-Jetronic

H2000H	8 mm x 1.0 Male Long
H2000HA	8 mm x 1.0 Female Long
H2000HH	10 mm x 1.0 Male
H2000J	8 mm x 1.0 Female
H2000K	12 mm x 1.5 Swivel Female (2)
H2000KA	14 mm x 1.5 Swivel M and F
H2000KB	16 mm x 1.5 Swivel M and F
H2000KC	1/4 BSPT Swivel M and F
H2000L	10 mm x 1.0 Female
H2000M	8mm x 1.0 Male (2)

Adapters for Chrysler® and Mitsubishi®

H2000M11	11 mm
H2000M15	15 mm
H2000M16	16 mm



7/8" with Cut-Away Oxygen / Vacuum Sensor Socket

H3327

- Removes and installs oxygen sensors and vacuum switches on computerized engine control vehicles
- 3/8" drive x 7/8" hex socket with cut-away slot provides extra clearance for oxygen sensor wires during use



1-1/16" Oil Pressure Sending Unit Socket

H3440

- Remove and install 1-1/16" oil pressure sending units up to 2-5/8" long
- Heat treated alloy steel
- Use with 3/8" square drive or 1-1/8" hex wrench
- Fits most 1991 to current GM® vehicles using oil pressure gauge and 1987 to current Chrysler® with light and gauge



7/8" 6 Point Oxygen Sensor Offset Socket Wrench

H3586

- Removes and installs oxygen sensors on vehicles with computerized engine control
- Offset design for increased maneuverability
- 7/8" 6 point socket with cut-away slot provides extra clearance for oxygen sensor wires during use



Oxygen Sensor Offset Socket Wrench

H3346

- Removes and installs oxygen sensors on vehicles with computerized engine control
- Offset design for increased maneuverability
- Features a 7/8" hex and 1/2" double square drive with cut-away slot providing extra clearance for oxygen sensor wires during use



29mm Narrow Slot Oxygen / Vacuum Sensor Socket

H3580

- 1/2" drive, 29mm narrow slot oxygen sensor socket



27mm Injector Socket

H3595

- 1/2" drive, 27mm x 3-1/4"
- With window



7/8" Narrow Slot Oxygen / Vacuum Sensor Socket

H3583

- 3/8" drive x 7/8"





BLOW GUNS

Spray Cleaning Gun Kit

H3192

- High speed 2-way action quickly blasts dirt, grease and oil
- Sprays cleaning solvents under high pressure. Will also blow air only
- Pressure trigger for maximum efficiency
- Includes 4 ft siphon hose with screen
- Operates with 1 hp or larger air compressor delivering 3.0 CFM at 60 psi
- Air inlet: 1/4" NPT

PULLERS AND PULLER KITS

Power Steering Pump & Alternator Pulley Tool

H3341

- 2-in-1 tool removes and installs pulleys
- Features a two sided flange which fits all domestic automobiles including GM®, Chrysler® and Ford®
- Remove and install Saginaw®, Thompson® and Ford® C-2 power steering pumps with grooved assemblies
- Works on alternator pulleys with the following grooved hub diameters:

SAE 1-1/8, 1-1/4, 1-5/16, 1-3/8"

Metric 28, 32, 34, 35 mm

⚠ CAUTION: Do not use with impact tool!

6 PC Power Steering Pump Pulley Kit

H3565

- Remove and install power steering pump pulleys without damage
- Use on most Chrysler®, Ford® and GM® vehicles
- Comes with two screw shafts for various pump sizes
- Fits pulley hub diameters of: **1-1/8, 1-1/4, 1-5/16, 1-3/8"**
- Comes in convenient blow mould storage case

Applications:

- 1988 - to current GM® Quad 4 engines
- 1989 - to current GM® 1/2", 3/4", and 1 ton pickups
- 1990 - to current Chevrolet Lumina® APV, Pontiac TransSport®, Oldsmobile Silhouette®
- 1991 - to current (3.1L V6 engines) Chevrolet Lumina® sedan, Olds Cutlass Supreme®, Buick Regal®, Pontiac Grand Prix®
- 1991 - to current Ford® (4.6L engines)
- The included H3353 disconnect coupler tool disconnects the fuel line on most 1987 - to current Cadillac®, Oldsmobile®, and Buick® vehicles

Power Steering Pump Pulley Kit

H3566

- Remove and install alternator and power steering pulleys on late model Chrysler®, Ford® and GM® engines
- Reverse the jaws to pull the alternator internal bearings
- Will not damage pump or pulley
- Comes in convenient blow mould storage case

Applications:

- 1988 - to current GM® Quad 4 engines
- 1990 - to current Chevrolet Lumina® APV, Pontiac TransSport®, Oldsmobile Silhouette®
- 1991 - to current (3.1L V6 engines) Chevrolet Lumina® sedan, Olds Cutlass Supreme®, Buick Regal®, Pontiac Grand Prix®
- 1991 - to current Ford® (4.6L engines)

Kit Includes:

- Pulley Body, Centre Bolt, 2 Piece Jaws with Retaining Ring, Bearing, Washer and small Button
- Puller Pins for Quad 4, GM® 3.1L
- Installing Screws for Quad 4, GM® 3.1L, Ford® 4.6L and others



1-1/4" Gear and Bearing Puller

H1905

- Unique spring action that permits a one handed operation
- Forces the jaws tighter as more pressure is applied to the pressure screw
- Pressure screw has a protector on the end to prevent damage to the object pulled
- The 1-1/4" capacity is ideal for small bearing, battery terminals and other small pulling jobs
- All parts are plated for rust and corrosion protection



5 PC Internal and External Bearing Puller Kit

H3562

- Remove internal and external bearing cups, seals, bushings etc
- Special cone adapter included which securely locks jaws on part to be removed
- Use with slide hammer for more torque
- Comes in convenient blow mould storage case

Kit Includes:

- 2.7 lb (1.24kg) Slide Hammer (5/8"-18 thread)
- Two Internal 3 Jaw Kits (Capacity 10 - 30mm, 30 - 80 mm)
- External 3 Jaw Kit (10 - 80 mm)
- Cone adapter





PULLERS & PULLER KITS

Steering Wheel Puller

H1903

- For all major makes of automobiles: 5/8" x 4" centre screw has recessed floating swivel
- Five Sets of (2 each) side screws: 3/8" - 16 x 4", 5/16" - 18 x 4-1/2", 5/16" - 24 x 3-1/2", 1/4" - 28 x 3", M8 x 1.25 x 80 mm

Harmonic Balancer Puller Kit

H1901

- Designed to pull balancers, vibration dampers, pulleys, or any tool with tapped holes.
- Two or three hole applications
- Floating swivel prevents damage to shaft ends
- Range: **1-3/8" - 3-9/16"**
- 5 sets of side screws provided

Pilot Bearing Slide Hammer Puller

H1921

- Slide hammer type
- Use to remove sleeve type bearings from 1/2" - 1-1/2" inside diameter on flywheels, pumps, and generators
- Turn the handle for quick adjustment and the centre rod spreads the alloy steel jaws for a tight fit inside the bearings
- A few light taps with the sliding hammer, and the bearing is removed

Slide Hammer Multi-Purpose Puller Set - Heavy Duty

H3560

- Extract flange-type rear axles, semi-floating rear axles bearings, balancers and other press-on parts
- With the 2/3 jaw combination, it can remove gears, outer races, grease retainers, oil seals and other internal/ external pulling jobs
- Use on most cars and light trucks that have axles with bolts and studs no larger than 9/16" in diameter
- Applies to 4.5 and 6 bolt stud circles that range from 4-1/4" - 5-9/16"
- Slide hammer is: 5 lb (2.32kg)
- Comes in convenient blow mould storage case

2 or 3 Jaw Combination Gear Pullers



- Assemble with 3 jaws for maximum stability, or with 2 jaws where access is limited - 2 pullers in 1
- Jaws, yokes and forcing screw made of heat treated Chrome Vanadium steel for ultimate strength
- Reversible jaw design allows internal and external pulling
- Jaws grip tighter as pulling force increases
- All components hardened to HRC 42~45 for professional use
- Fine threaded 440 CrV forcing screw precise control for damage free pulling
- Can be used with bearing separators



PROD. NO.	MOD. NO.	Reach	Spread	Capacity	Screw Length	Pitch	Jaw Thickness	Jaw Width
770132	JGP-3HD	3-1/4"	4-3/4"	2 tons	4.9"	3/8"-24 tpi	1/8, 1/4"	1/4, 7/16"
770133	JGP-4HD	3-1/2"	7"	5 tons	7"	9/16"-20 tpi	1/4, 5/16"	3/8, 3/4"
770134	JGP-6HD	5-1/2"	7"	5 tons	7"	9/16"-20 tpi	1/4, 5/16"	3/8, 3/4"
770135	JGP-8HD	5-1/2"	9-1/2"	5 tons	9"	11/16"-18 tpi	5/16, 11/32"	7/8"

BEARING SEPARATORS - HEAVY DUTY

- Separator bodies made of heat treated Chrome Vanadium steel for maximum strength
- All components hardened to HRC 42~45 professional use
- Separators have knife like edges to get behind bearings where regular gear puller jaws are too thick to grip
- Can be used with push or pull type gear pullers



12 PC Bearing Separator Set 770302/JBS-12

- Includes components to assemble push-type puller

Maximum Reach	Capacity	Forcing Screw	Hole Size
3"	5 tons	7", 9/16" x 10 tpi	3/8" x 16 tpi

Contents: 2-1/4" Bearing Separator (1), 3-1/2" Bearing Separator (1), Yoke (1), Forcing Screw (1), Main Rods (4), Extension Rods (4)



Open Stock

PROD. NO.	MOD. NO.	Capacity	Hole Size
770312	JBS-225	1-3/16" - 2-1/4"	3/8" x 16 tpi
770313	JBS-350	2-1/4" - 3-1/2"	3/8" x 16 tpi
770314	JBS-450	3" - 4-1/2"	1/2" x 16 tpi





GEAR PULLERS

See page 239 Pullers section for similar products



GEAR PULLERS

22 PC Hydraulic Gear Puller Kit

770152 / JHGP-10S

- Jaws, yokes, bearing separator and ram made of heat treated Chrome Vanadium steel for ultimate strength
- Hydraulic ram requires no power - develops up to 10 tons of pressure with hand power only
- All components hardened to HRC 42~45 for professional use
- Includes twin and triple heads for assembling 2 jaw and 3 jaw pullers
- Includes 4-1/2" bearing separator
- Comes in convenient blow mould storage case

Reach	Spread	Capacity
4"	10"	10 tons

Contents:

Hydraulic Ram (1), 4" Puller Legs (3), 6" Puller Legs (3), 8" Puller Legs (3), Collar (1), Twin Head (1) Triple Head (1) End Cap (1), 2" Ram Extension (1), Yoke (1), 4-1/2" Bearing Separator, Main Rods (2), Extension Rods (2)



HAND BRUSH

Parts Cleaning Brush

H1039

- Chemical resistant bristles are crimped to hold more fluid for faster cleaning
- The bristles are tapered to get into tight places
- Plastic handle

Razor Blade Scraper - Folding Arm Style

H1363

- All purpose scraper
- Locks in three positions
- Handy to remove inspection stickers, paint, masking tape and general scraping jobs
- Rugged steel construction
- One steel blade included



Razor Blades - Single Edge (100/Pack)

H1363C

- 100 per box
- Steel blades fit all single edge blade holders

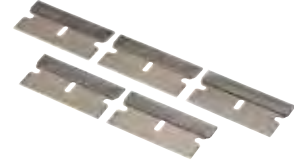

Razor Blade Scraper - Extended Arm Style

H1364

- All purpose scraper
- Designed for hard-to-reach areas to remove inspection stickers, paint, masking tape and general purpose scraping
- Ergonomic handle with steel shaft
- One steel blade included
- Overall length: 12-1/2"
- Replacement blade: H1363C (box of 100)



Razor Blade Scraper - Stubby Pocket Style (30 PC)

H3237DA

- Sturdy scraper for home, auto or shop
- Compact pocket size
- Remove stickers, labels, paint etc
- Colourful easy grip cushioned handle
- Uses standard single edge razor blades (see above)
- H3237DA Cookie Jar Counter Display Assortment
- Contains 30 - mini scrapers in 5 assorted coloured handles
- Cookie Jar is non-breakable plastic with snap shut lid



H3237DA

SEAL PULLER

Seal Puller

H3052

- Easily removes oil and grease seals on automobiles and light trucks
- Two different tips reach in and fit most seals





5 Blade Non-Magnetic Feeler Gauge

H1137

- Blades made of non-magnetic brass and will not affect the electronic components of the distributor
- Five blades cover the sizes needed
- Metric equivalents marked on blade
- Blade Thickness: **.006 .008 .010 .012 .014 .016**



25 Blade Universal Master Gauge

H1859

- Metric equivalents marked on blades
- .0015 plus .002 to .035 in .001 increments
- Blade Size: 3-1/16" x 1/2"
- Blade Thickness: **.0015, .002, .003, .004, .005, .006, .007, .008, .009, .010, .011, .012, .013, .014, .015, .016, .018, .020, .022, .024, .025, .028, .030, .032, .035**

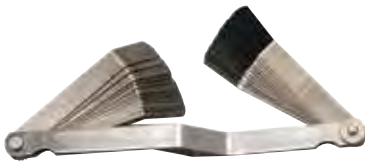

21 Blade Extra Length Offset Style Feeler Gauge

H1863

- Blade Sizes: 4" x 1/2", 1"-45° offset
- Blade Thickness: **.006 .007 .008 .009 .010 .011 .012 .013 .014 .015 .016 .017 .018 .019 .020 .021 .022 .023 .024 .025 .026**



22 Blade Go, No-Go Style Feeler Gauge

H3105

- Blade Sizes: 3" x 1/2" Step Ground
- Blade Thickness: **.004-.006 .005-.007 .006-.008 .007-.009 .008-.010 .009-.011 .010-.012 .011-.013 .012-.014 .013-.015 .014-.016 .015-.017 .016-.018 .017-.019 .018-.020 .019-.021 .020-.022 .021-.023 .022-.024 .023-.025 .024-.026 .025-.027**



H3370

- Heat-treated steel, black oxide finish to prevent corrosion
- Use with 3/8" square drive ratchet
- Tough, durable, built to last
- Wrenches are specifically designed for 1 or 2 step models, fitting various flute designs on Fram, AC, Casite, Lee, Hastings, Motorcraft, NAPA, Purolator, STP, Pure One, Wix and some Japanese and European made filters



14 PC Cap Style Filter Wrench Set

H3370

Contains:

PROD. NO.	Metric Size	Decimal Equivalent	Flutes
H3371	74/76 mm	2.91/3.0"	15 - 2 steps
H3372	76 mm	3.00"	14
H3373	93 mm	3.66"	15
H3374	73 mm	2.875"	14
H3375	65/67 mm	2.56/2.63"	14 - 2 steps
H3376	68 mm	2.68"	14
H3377	80 mm	3.15"	15
H3378	90 mm	3.54"	15
H3379	80/82 mm	3.15/3.23"	15 - 2 steps
H3380	93 mm	3.66"	36
H3381	75/77 mm	2.95/3.03"	15 - 2 steps
H3382	65 mm	2.56"	14
H3383	76 mm	3.00"	30
H3384	100 mm	3.937"	15

Cap Style Filter Wrench - Dual Size

H1099

- For installing or removing oil filters
- Fits most makes and models of filters with fluted ends. Won't damage filter
- Steel / nickel plated uses 3/8" square drive socket wrench or 1" open end wrench to operate
- Dual Size for 2-7/8 - 3"
- Compact Size Filters - 15 Flutes

14 PC 3/8" DR Oil Drain Plug Socket Set

H3700

- Fits oil drain plugs on most domestic, European and Asian vehicles
- Great for oil change professionals
- Bright-finished Chrome Vanadium steel sockets comes on a metal clip rail



Contains:

H3700-10	3/8" Dr. Oil Drain Plug Socket (8 mm Hex)
H3700-11	3/8" Dr. Oil Drain Plug Socket (9 mm Hex)
H3700-12	3/8" Dr. Oil Drain Plug Socket (10 mm Hex)
H3700-13	3/8" Dr. Oil Drain Plug Socket (12 mm Hex)
H3700-14	3/8" Dr. Oil Drain Plug Socket (14 mm Hex)
H3700-15	3/8" Dr. Oil Drain Plug Socket (17 mm Hex)
H3700-16	3/8" Dr. Oil Drain Plug Socket (10 mm Square)
H3700-17	3/8" Dr. Oil Drain Plug Socket (7 mm Square)
H3700-18	3/8" Dr. Oil Drain Plug Socket (8 mm Square)
H3700-19	3/8" Dr. Oil Drain Plug Socket (11 mm Square)
H3700-20	3/8" Dr. Oil Drain Plug Socket (13 mm Square)
H3700-21	3/8" Dr. Oil Drain Plug Socket (5/6" Square)
H3700-22	3/8" Dr. Oil Drain Plug Socket (3/8" Square)
H3700-23	3/8" Dr. Oil Drain Plug Socket (10 mm Triangle)



4 PC Oil Filter Canister Socket Set

H3702

- Specially designed low profile 3/8" sq. drive sockets used for removing oil filter canister cover on vehicles that have limited access
- Cartridge type oil filters are easier to change with these specialty sockets
- When using a conventional socket, the top side of the socket can contact other surrounding components which could cause damage or make it difficult to completely remove the oil canister cover
- Made from Chrome Vanadium Steel (CRV)
- Not for use with impact tools
- Contains:

H3702-10	Oil Filter Canister Socket (24 mm)
H3702-11	Oil Filter Canister Socket (27 mm)
H3702-12	Oil Filter Canister Socket (32 mm)
H3702-13	Oil Filter Canister Socket (36 mm)



Band Type Filter Wrench - Non-Swivel Handle**H1014**

- Stainless steel band is 7/8" (22.2mm) wide
- Full length ergonomic cushion grip handle for comfort
- All steel handle construction, plated for rust protection
- Studs on inside of band help prevent slipping
- Farm and Fleet
- Range: **4-3/4" - 5-1/8" (120.6 - 130.1 mm)**

**Band Type Filter Wrenches - Swivel Handle**

- Features a self-locking bolt in the handle instead of a rivet for less wear and tear
- Stainless steel band is 1" (25mm) wide, supported on the outside joint
- Full length ergonomic cushion comfort grip handle for comfort
- All steel handle construction, plated for rust protection
- Studs on inside of band help prevent slipping



PROD. NO.	Type	Range
H1060	Small	2-3/8" - 2-7/8" (60.3 - 73 mm)
H1061	Compact	2-7/8" - 3-3/8" (73 - 85.7 mm)
H1062	Standard	3-3/8" - 3-3/4" (85.7 - 95.2 mm)
H1063	Large	3-3/4" - 4-3/8" (95.2 - 111.1 mm)

Band Type Truck Filter Wrenches - Swivel Handle

- Designed for use on Cummins, Detroit Diesel and Caterpillar engines
- Has a self-locking bolt so that wear can be taken up after long use
- Steel bands one full inch wide
- Full length cushion grip handle for comfort
- Studs on inside of band help prevent slipping



PROD. NO.	Type	Range
H3433	Cummins & Detroit Diesel Engines	4-5/16" - 4-3/4" (110 - 120 mm)
H3434	Caterpillar Engines	5-1/4" - 5-3/4" (134 - 146 mm)

Expandable Filter Wrench**H3055**

- Removes all passenger car and light duty truck spin on type oil filters
- Serrated legs provide strong gripping power
- Range: **2-3/8" - 4-3/4" (60.3 - 120.7 mm)**
- Use with 3/8" square drive



H3078



H3055

1/2" Square Drive Oil Filter Wrenches - Heavy Duty

PROD. NO.	Range
H3078	4-1/8" - 4-21/32" (104 - 118 mm)
H3079	4-21/32" - 5-5/32" (118 - 131 mm)
H3090	5-5/32" - 5-21/32" (131 - 144 mm)

Strap Filter Wrench - Standard**H1295**

- For installing or removing oil filters
- Adjusts quickly to oil filter. Use with square drive ratchet handle or open-end wrench
- Strap is made of a durable oil resistant nylon web that will not slip
- For cars and trucks: 6" capacity
- 1/2" square drive or 3/4" open-end wrench

**Heavy Equipment Band/Strap Filter Wrench****H3241**

- Heavy duty cordura strap for high torque requirements
- Tightening and turning device has 3/8" square drive on one end and 1/2" square drive on the other
- Range up to **9" (228 mm)** approx.
- Strap length approx. 25"

**Oil Filter Removal Pliers****H3310**

- For removal and installation of spin-on oil and fuel filters
- Self-adjustable. Spring action slip joint. Gripping jaws and cushion grip handles
- Range: **2-1/4" - 6" (60 - 152 mm)**



DRIVER BITS AND SOCKETS



4 PC Triple Square Driver Bit Set

H1456

- For use on 12 point fasteners
- Triple square design. Alloy steel
- Made from Chrome Vanadium 6150
- 50 - 54 Rockwell Hardness

Contains: Bit size 6, 8, 10, 12 mm



8 PC 3/8" DR Triple Square Driver Bit Set

H1458

- Black oxide tip, matte finish and made from SNCM 8660 steel
- For use on triple square fastener bolts typically found on European vehicles (especially German)
- For use on cylinder heads, axle shafts, rear toe adjusters, differentials, transmission drain plugs, clutches, belly pans, brake calipers and more
- Other uses include: Detroit Diesel® flywheel bolts, crank pullers on 900 & 4000 series engine, and headbolts on 900 series
- Bit sockets are NOT designed for use with power impact tools

CAUTION: Triple square bit sockets may strip the head of double hex bit fasteners found on many Asian vehicles



	Socket Size		Socket Size
H1458-10	4 mm	H1458-14	10 mm
H1458-11	5 mm	H1458-15	12 mm
H1458-12	6 mm	H1458-16	14 mm
H1458-13	8 mm	H1458-17	16 mm

STUD, BOLT AND NUT REMOVAL

Nut Splitting Tool

H1858

- For removal of rusted or corroded nuts. It will split nuts up to 3/4" across flats, just a few turns with any 3/4" hand wrench (no power needed)
- Especially handy for front and rear shock absorber stud-end nuts
- Overall length: **4-1/8"**



H1858

PUNCHES - BRASS

- Ideal when sparks from a steel punch would be dangerous
- A must for those driving jobs where a soft punch is required

Tapered Punch (5/8" Hex to 3/8" Point)

H3095

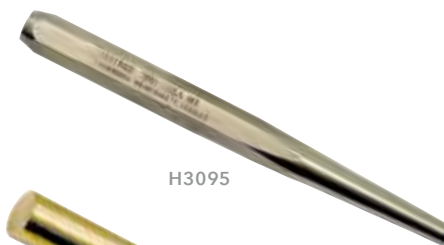

H3095

Drift Punch (3/4" Diameter - Knurled Grip)

H3096



H3096

PLIERS

Universal Lock Ring Pliers

H3056

- Removes and installs lock rings used on brakes, transmissions, pedal shafts and clutch shafts
- The scored jaws hold rings securely



H3056



SCREWDRIVERS



15-in-1 Multi Bit Screwdriver

H3400

- Features a patented pullout bit cartridge
- 14 of the most popular bits means one multi-driver replaces 14 screwdrivers and one 1/4" hex nut driver
- 2" double end bits are made of superior quality S2 steel for strength and durability
- Shaft is made of super high strength 12T14 steel for long life
- End of shaft is a 1/4" hex nut driver
- Handle is made of durable nylon reinforced triax resin for longest life.
- Unique rotating cap design allows you to position the cap in the palm of your hand and rotate the driver handle with your fingers. The driver then acts like a gearless ratcheting screwdriver, increasing productivity while reducing blisters and operator fatigue
- Collar also swivels 360° for fast, efficient driving of screws
- Made in the U.S.A.

Distributors please note: Drivers are sold in 6 pack POP displays only.

REPLACEMENT BITS:

H3400C	PH 1+PH3
H3400D	PH1+PH2
H3400E	S1+S2
H3400K	S0+S3
H3400J	F4+F6
H3400F	T10+T15
H3400G	T20+T25
H3400H	T27+T30



SCREW EXTRACTORS

5 Piece Flute Type Screw Extractor Set

H1273

- Five extractors with sharp undercut edges to provide solid grip in studs, set screws, pipes and zerk fittings
- Made from Chrome Molybdenum (50 - 52 Rockwell hardness)



Contains:

	U.S.S. Screw or Bolt Size	Drill Size	Min. Depth of Hole	Pipe Size
H1273A	1/4", 5/16"	1/8"	3/8"	
H1273B	3/8"	3/16"	1/2"	
H1273C	7/16"	15/64"	1/2"	1/8"
H1273D	1/2", 9/16"	5/16"	1/2"	1/4"
H1273E	5/8"	3/8"	5/8"	3/8"



5 Piece Spiral Type Screw Extractor Set

H1365

- For removing broken screws, bolts and threaded parts
- Spiral type flutes grip and remove the broken part
- Precision Chrome Molybdenum (48-52 Rockwell hardness), tapered and ground
- Comes in a convenient vinyl pouch



Contains:

	Screw or Bolt Size	Drill Size
H1365A	1/8 - 1/4"	1/16"
H1365B	1/4 - 5/16"	7/64"
H1365C	5/16 - 7/16"	5/32"
H1365D	7/16 - 9/16"	7/32"
H1365E	9/16 - 3/4"	17/64"



WARNING: Always wear safety goggles

Thread File (Coarse SAE) H1440

- **11, 12, 13, 14, 16, 18, 20, 24** (threads/inch)

Thread File (Fine SAE) H1441

- **9, 10, 12, 16, 20, 27, 28, 32** (threads/inch)

Thread File (Metric) H1442

- **0.75, 1.0, 1.25, 1.50, 1.75, 2.00, 2.50, 3.00 mm**



H1440 - H1442

Threaded Die Sets

- Hex shape lets you use a common socket for a holder
- Will quickly and safely repair damaged threads on bolts or rods on bolts or rods
- Each set packed on ball chain



PROD. NO.	Pieces	Type	Contents
H1345	7	Fine	1/4, 5/16, 3/8, 7/16, 1/2, 9/16, 5/8
H1346	5	Metric	6 mm x 1.0, 7 mm x 1.0, 8 mm x 1.25, 10 mm x 1.50, 12 mm x 1.50 Use H1346-11 for 7 mm x 1.0 Die

43 PC Rethreading Die Set – SAE/Metric H3573

- A comprehensive re-thread kit for repairing or renewing damaged threads on nuts, bolts or studs
- Hex-shaped for socket or wrench use
- Comes in a convenient blow mould storage case

21 DIES		19 TAPS		3 Thread Files (4 sided)		
UNC - National Coarse (Silver)		UNC - National Coarse (Silver)		H1440	SAE	Coarse 11, 12, 13, 14, 16, 18, 20, 24
H3573-10	1/4"-20 UNC	H3573-17	1/4"-20 UNC	H1441	SAE	Fine 9, 10, 12, 16, 20, 27, 28, 32
H3573-11	5/16"-18 UNC	H3573-18	5/16"-18 UNC	H1442	Metric	0.75, 1.00, 1.25, 1.50, 1.75, 2.00, 2.50, 3.00 mm
H3573-12	3/8"-16 UNC	H3573-19	3/8"-16 UNC			
H3573-13	7/16"-14 UNC	H3573-20	7/16"-14 UNC			
H3573-14	1/2"-13 UNC	H3573-21	1/2"-13 UNC			
H3573-15	9/16"-12 UNC	H3573-22	9/16"-12 UNC			
H3573-16	5/8"-11 UNC	UNF - National Fine (Black)				
UNF - National Fine (Black)		H3573-30	1/4"-28 UNF			
H3573-23	1/4"-28 UNF	H3573-31	5/16"-24 UNF			
H3573-24	5/16"-24 UNF	H3573-32	3/8"-24 UNF			
H3573-25	3/8"-24 UNF	H3573-33	7/16"-20 UNF			
H3573-26	7/16"-20 UNF	H3573-34	1/2"-20 UNF			
H3573-27	1/2"-20 UNF	H3573-35	9/16"-18 UNF			
H3573-28	9/16"-18 UNF	Metric (Gold)				
H3573-29	5/8"-18 UNF	H3573-43	6 mm x 1.00			
Metric (Gold)		H3573-44	8 mm x 1.25			
H3573-36	6 mm x 1.00	H3573-45	10 mm x 1.25			
H3573-37	8 mm x 1.25	H3573-46	10 mm x 1.50			
H3573-38	10 mm x 1.25	H3573-47	12 mm x 1.25			
H3573-39	10 mm x 1.50	H3573-48	12 mm x 1.50			
H3573-40	12 mm x 1.25	H3573-49	12 mm x 1.75			
H3573-41	12 mm x 1.50					
H3573-42	12 mm x 1.75					



WARNING: Do not use with impact or power tools



POST AND TERMINAL SERVICE

5/16" Side Terminal Wrench

H3125



- Designed to easily remove 5/16" side terminal battery bolts
- Insulated handle to prevent electrical shock
- Reversible 5/16" ratcheting box wrench allows for quick and effective terminal bolt removal

Post and Terminal Cleaning Brush

H1007



- Remove corrosion quickly and safely. Cleans battery post and terminals for perfect electrical contact
- Also useful as a wire cleaning brush for cleaning 1/2" copper pipe before sweating
- Metal case included

Post and Clamp Cleaner

H1677



- Quickly and safely cleans even the most corroded terminals
- Double ended post cleaner handles both the positive and negative posts
- The tapered reamer cleans both size terminals
- Constructed of high quality steel and shock proof plastic

Post and Terminal Cleaner

H3391



- Cleans and reams battery posts and terminals
- Post cleaners marked with positive and negative symbols for easy identification

BATTERY CARRIER

Grip-Tight Battery Carrier

H1279



- For most 6 and 12 volt batteries
- Rugged, zinc plated steel jaws grip battery securely for lifting
- Acid resistant, non-conductive strap
- Designed to carry side terminal or post batteries
- Easy one hand control

100 Amp Analogue Load Tester

H3432

- **Tests 6 and 12 volt batteries up to 1,000 CCA**
- Tests battery state of charge, battery cranking ability, charging system output and starter condition
- Easy to read meter
- Accurate and shock resistant movement
- Heavy duty colour coded, insulated clamps
- Durable, ventilated blue enamel steel case
- Top mounted rocker switch is more convenient and easy to use
- Rubber insulated carrying handle for both comfort and safety
- Complete tests done in 10 seconds
- Outside power is not required
- True 100 amp load capacity
- Unit does not contain asbestos



100 Amp Digital Load Tester

H3650

- **Test 12 volt batteries only up to 1,000 CCA**
- Tests: battery state of charge, battery cranking ability, charging system output starter test
- Microprocessor controlled design guarantees an easy and accurate load test and no need to time yourself
- Unique 3 step design: LED polarity checking function, battery state of charge and charging system test readout
- Check both battery and charging systems
- Durable, ventilated enamel steel case
- Completely portable; outside power is not required
- True 100 amp load capacity



500 Amp Carbon Pile Tester

H3655

- **Tests batteries up to 1,000 CCA**
- For **12 volt batteries**, alternators, regulators & starters systems
- Colour-coded, temperature compensation pass/fail bands on the voltmeter insures precise battery load test results
- Separate voltmeter and ammeter, for easy monitoring
- Fully insulated, heavy duty, colour coded battery clamps & wire leads
- Designed with built in 15 second load warning beeper
- Meets UL and CE standards
- The JET ADVANTAGE: There are many 500 amp carbon pile battery tester and charging system analyzers in the market. While they all look the same from the outside, our unit has many important features that ensure a premium quality tester. Our carbon piles are made from the best quality, superior performing materials. Our steel parts are made with patented "constant-pressure/constant current" steel. The fasteners and soldering materials and assembly technology insure the components and connection stay secure. We use heavy duty 4 gauge welders' grade cable wire where competitors may use lighter gauge cable. These superior components and design qualities offer greater stability and more accurate readings while minimizing heat build up





ELECTRIC TESTERS

Circuit Tester – 6/12 Volt

H1090

- Test electrical circuits, relays, bulb, and switches
- Attach the ground clip to any good electrical ground and touch the probe to the hot end. If the bulb lights up, the circuit is good
- Bulb will take a nominal overload for safety
- Uses standard replacement bulb
- Hi-impact, no shock, plastic case
- H1090C replacement bulb

Continuity Tester

H1494

- Self-powered tester will check all voltage circuits and wiring, with the vehicle power off
- Uses standard AA battery. Battery included
- Test radio, T.V., appliances, electrical circuits, switches, voltage regulators, coils, fuses, condensers, armature and alternator diodes
- Bulb is mini screw base 1.5 V industry standard No. 112, purchase locally
- Lead is 36" long

Circuit Tester – Deluxe 36 Volt

H1493

- This unit does it all. It will test all voltages from 6 - 36 volts
- A special high voltage neon tube will also let you test spark plugs and spark plug wiring
- The coiled wire lead extends up to 6 feet and retracts compactly
- Heavy duty large type clamp
- A very good all around tester
- H1090C replacement Bulb

Circuit and Polarity Tester - Computer Safe

H3068

- Designed to be used on all 12 volt circuits including automotive computer circuits without damage to sensitive electronic components
- It draws less than 21 milliamps at 12 volts DC with an operating range of 3 - 15 volts
- Has a long life LED bulb
- Glows RED to indicate positive polarity at probe and GREEN to indicate negative polarity

Circuit Tester With Buzzer - 6/12/24 Volt

H3344

- Bulb lights and buzzer sounds when positive contact has been made
- Ideal for use in tight spaces or under bright lights where a light is difficult to see
- Tests 6 - 12 - 24 volt "power-on" circuits
- Clip enclosed in anti-shock boot
- Features long life LED bulb
- Extra long 42" 16 - gauge wire

Remote Starter Switch

H1361

- Remote switch allows the mechanic to crank engine from outside of vehicle while keeping hands away from fan blades, gears, or other moving parts.
- Heavy duty switch contacts reduce arcing
- May be used to open and close other low voltage circuits.
- Leads are 35" long

Ford® Triton Spark Plug Thread Repair Kit

H3660

- Designed to aide in repairing spark plug threads damaged on Ford® Triton Modular Engines - 1996-2003 - 4.6LT, 5.4LT, 6.8LT V-10
- Becoming one of the most asked for repairs as these engines age
- Repair damaged cylinder heads from spark plug thread erosion and shooting spark plugs out during operations with a patented "Alloy Steel Insert"
- Foolproof repair system that is fast, cost effective and simple to use
- Takes as little as 15 minutes, to no more than 45 to repair one cylinder

Kit Contains:

- Core drill, guide, hose assembly, instructional DVD, 6 -M14 x 1.25 x 19mm O.D. alloy inserts, all in a blow mould case
- Replacement parts: H3660-10 spark plug insert



Ford® Triton Spark Plug Shield Extractor Kit

H3661

- Designed to extract frozen or broken spark plug ground electrode shields in Ford® Triton engines 2004 to present – 4.6LT, 5.4LT, 6.8LT V-10
- The elongated plug has a stainless steel shield – as the carbon deposit builds-up, the shield sticks and stays in the cylinder head spark plug well
- Use the specially machined guide with tap 9mm x 8" L (203.2mm) to tap the shield
- Use the extractor to pull out the stainless steel sleeve
- Problem solved; saving time and a huge expense

Kit Contains:

- 1 each: guide, Tap 9mm x 8" L (203.2mm), extractor, nut, washer and 4 rubber stopper caps, all in a blow mold case



Ford® Triton Spark Plug Porcelain Extractor Kit

H3659

- Designed to extract frozen or broken porcelain part of the spark plug in the 3 Valve Ford Triton engines (2004 to present)
- Using these special tools and a strong epoxy you should be able to extract the broken porcelain left behind when spark plug removal was attempted
- The advantage of this method of extraction is to prevent broken pieces of porcelain from entering the combustion chamber
- Ford specifically does NOT recommend pushing the broken porcelain down into the cylinder, doing so would mean the removal of the cylinder head

Kit Contains:

- 1 - Epoxy applicator with guide, 1 - epoxy electrode applicator and extractor assembly, 1 - Small tube of bonding epoxy (Loctite)
- Replacement epoxy. Use Loctite No. 638 or Permatex No. 64000 or 64050
- Replacement parts: H3659-10 epoxy applicator
H3659-11 epoxy pins - 10 pack



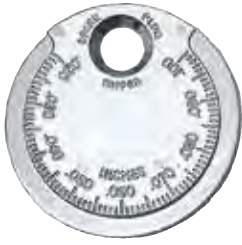

SPARK PLUG/IGNITION TOOLS

Spark Plug Gauge and Gapper

H3116

- For standard and H.E.I. ignition
- Has tapered ground edge for gapping plugs. Adjusting hole with flange to adjust side wire without pressuring centre electrode
- Has both metric and decimal markings
- Gaps all plugs from: .020 - .100 (0.50 - 2.5 mm)

Spark Plug Thread Chasers

H1066

- For spark plug holes
- Chaser cleans threads of dirt, carbon build-up and metal particles
- Services most applications including compacts and subcompacts
- Rubber ring holds chaser firmly in socket
- Dual Size: 14 mm and 18 mm
- Use with 13/16" deepwell socket

5 Piece Magnetic Spark Plug Socket Set

H3704

- Long reach magnetic swivel spark plug socket set
- For hex sizes 5/8", 13/16" and the new 9/16" on Ford® Triton engines
- Made from CrV steel, with a bright hard chrome finish

Set Includes:

- 3/8" Dr x **9/16" HEX x 2-1/2" (66 mm)** Long
- 3/8" Dr x **5/8" HEX x 4" (101.6 mm)** Long
- 3/8" Dr x **5/8" HEX x 6" (152.4 mm)** Long
- 3/8" Dr x **5/8" HEX x 11" (279.4 mm)** Long
- 3/8" Dr x **13/16" HEX x 6" (152.4 mm)** Long

CrV

Digital Automotive Multimeter

H3630

- Full-range - performs complete tune-up and troubleshooting tests on all vehicles
- Includes tests such as tach and dwell, fuel injectors, sensors, alternators, spark plug wires, ignition and charging systems, battery condition and cranking voltage
- Easy-to-read digital LCD
- Data hold function
- Computer safe

Functions:

DC Volts	200m-2-20-200-1000V
AC Volts	200-750V
DC Amps	20m-200m-10A
OHMS	200-2k-20k-200k
Frequency	20kHz
Dwell	3-4-5-6-8CYL
Tach	3-4-5-6-8CYL (X10RPM)
Temperature	-40° C/-40° F / 1,400° C/2,552° F
Diode check	3V/1mA
Continuity	Audible BEEP
Transistor hFE	Vce≈3v, Ib≈10μA

Features:

- 10M Input Impedance
- Auto reverse polarity
- Auto zero adjust
- Over range Indication
- Overload protection
- Low battery indicator
- Fuse Protection
- 9-Volt power
- Auto power off
- 9V Battery

Accessories:

- Colour-coded test leads
- Inductive spark pickup clamp
- Temperature Probe
- Detailed manual
- Holster

PH3630-10
Lead SetPH3630-12
Inductive Clamp



H1122 H1386

H1229

MISCELLANEOUS

Mechanics 4-In-1 Pick Set

H1244

- Good quality metal scribes designed at different angles to meet the mechanic's needs
- Comes complete with 4 picks and one master handle
- Handy storage pouch

Telescopic Mirror (2-1/4" Round Face)

H1105

- Double ball joint links swivel mirror for viewing to 360°
- Linkage designed to withstand constant repositioning of mirror, to move freely and yet hold desired position
- Telescoping handle: **9-1/2" - 14"**

Telescopic Pocket Mirror (1" x 2" Oval Face)

H1230

- Double ball adjustment head
- Convenient pocket clip
- Telescoping handle: **6-3/4" - 24-3/4"**

Telescopic Mirror (Large Rectangular Face)

H3103

- Double ball joint hinge adjusts to almost any angle
- Handle end has easy grip vinyl coating
- Telescoping handle: **11" - 15-1/2"**

MAGNETIC PICK-UP TOOLS

Flexible Pick-Up Tool

H1080

- Bends in any direction to hold or pick up objects
- Handy squeeze action gives close control
- Mechanical fingers grip securely
- Reach: **15"**

Adjustable Pocket Telescoping Magnet

H1386

- Extends up to **23"**
- Lifts up to **3-1/2 lb**

Long Adjustable Telescoping Magnet

H1122

- This heavy duty Alnico magnet will lift many times its own weight
- The flex head gets into tight places
- Bright plated with a comfortable plastic handle
- Shaft telescopes from **16-3/4" - 26-3/4"**
- Lifts up to **5 lb**

Flexible Magnetic Pick-Up Tool

H1229

- Flexible Alnico 5 magnetic pickup tool with knurled handle
- Flex shaft holds its set
- Overall length: **21"**
- Diameter: **5/16"**
- Lifts up to: **5-1/2 lb**

TIRE PRESSURE GAUGES



Pencil Tire Pressure Gauge - Chrome Plated

H1141

- Quality gauge ensures accuracy, long life and trouble-free performance
- High chrome plated finish
- Calibrated on two sides from **5 - 50 PSI** and in metric **40 - 350 kPa**
- Comes with handy pocket clip



Pencil Tire Pressure Gauge - Metal Body

H3262

- Durable metal chuck and body
- Handy pencil style with pocket clip
- Four sides plastic slide bar
- Calibrated in **5 - 50 PSI** and **40 - 350 kPa**



Distributors please note :
H3262 tire gauges sold in an
attractive 24 pack POP display only

Dual Chuck Tire Gauge - Small

H3162

- Accurately measures from **10 - 120 PSI**. Also calibrated in kg
- Chrome plated ABS dual offset heads
- Stem enclosed in metal body
- Shockproof
- Includes spring pocket clip
- Overall length: **6-3/4"**



Dual Chuck Tire Pressure Gauge - Large

H1503

- Dual chuck for use on trucks and passenger cars. Will withstand rugged use
- Angled dual chuck to reach inner and outer tire valves
- Indicator bar calibrated **10/200 PSI in 2 lb increments** and **metric 1/14 kg**
- Includes hang up ring
- Overall length: **13"**





Head assembly swivels 360°

Easy to read recessed sight glass



Large LED display



TIRE PRESSURE GAUGES

360° Swivel Head Truck Tire Gauge - Angle and Straight-On

H3274

- Heavy duty truck tire gauge
- Head assembly swivels 360°
- Easy-to-read, recessed sight glass
- Needle holds reading until bleeder valve is released
- High chrome plated finish
- Pressure range **10 - 120 PSI in 2 lb increments**

360° Swivel Head Digital Tire Pressure Gauge

H3276

- Simple to operate
- Clear, large LCD display (30mmx 15mm) with built-in backlight
- Audible buzzer
- Replaceable battery (LED), lithium and LR44 alkaline
- Measuring range to **150 PSI**
- Calibration in PSI, Bar, Kg/cm² and kPa
- Resolution: **0.5 PSI (0.05 Bar or 5 kPa)**
- Accuracy: +/- 1% + 0.5 PSI at 100 PSI and +/- 2% + 0.5 PSI at 150 PSI
- Operating Temperature: **50°F - 86°F (10°C - 30°C)**
- Head assembly swivels 360°
- Straight and 30° reverse angle chuck for monitoring inside and outside dual wheels
- 11-7/8" x 7-1/4"

- Needle holds readings until released by pressing relief button
- Zinc Alloy body, all chrome plated with acrylic lens
- Range: **10-100 PSI, in 2lb increments with metric kPa reading**
- Distributors please note: H3266 tire gauges are sold in an attractive 12 pack POP display only
- For single units order H3264

PROD. NO.	Description
-----------	-------------

H3264	Dial Type Tire Gauge
-------	----------------------

H3266	Dial Type Tire Pressure Gauge (10-100 PSI) – 12 Piece Counter Display
-------	-----------------------------------------------------------------------

TIRE VALVE TOOLS



Valve Core Tool - 4-in-1 Style

H1142

- Removes and replaces tire valve cores, rethreading inside and outside of valve stem
- E-Z out for backing out valve insides when shoulders are broken off
- Made of high grade tempered steel.
- Nickel plated



Tire Tread Depth Gauge

H1151

- Accurately determines the amount of tread left on tire
- Brass construction with high chrome plated finish
- 3 sides calibrated in **1/32" increments up to 1" depth**
- 3 sides calibrated in **millimeters in increments up to 25 mm depth**
- Handy pocket clip



Valve Core Tool

H1147

- A compact tool with aluminum handle and steel shaft
- Handle provides a sturdy grip
- For standard size valve core
- Overall length 5"



PLIERS FOR WHEEL WEIGHTS

Wheel Weight Pliers with Spring Loaded Handles

H1116

- Remove and install all types of clip-on wheel weights
- Invisible spring loaded handle keeps the jaws in the open position for ease of operation
- Ergonomic handle design with coated grips for comfort
- Built in cutter to cut wheel weights
- Handle ends have a flat or pointed end for prying or lifting
- Made of Chrome Vanadium steel
- Length: **9-3/4"**





Rubber protected



360° swivel easy to read gauge



H1143

H1145



H1144



H1302



H1301

AIR INFLATOR GAUGES

Air Line Inflator With Tire Gauge – Bayonet / Slide Type

H3282

- 2-in-1 tool, inflate and measure tire pressure levels
- Lever action
- Heavy duty construction provides long service life
- Zinc chrome plated body with brass internal parts
- 360° swivel dual foot chuck
- Includes a 1/4" x 12" air hose rated at W.P. 300 PSI
- Range: **10 - 90 PSI in 2 lb increments**

Air Line Inflator With Tire Gauge – Dial Type

H3284

- 3-in-1 tool, air line inflator and deflator with tire pressure gauge
- Heavy duty construction provides long service life
- 360° swivel easy-to-read gauge with heavy duty rubber gauge head protector
- Includes a 1/4" x 5 foot air hose rated at W.P. 300 PSI with 360° swivel straight safety clip-on air chuck
- 1/4" NPT female
- Range:
10 - 170 PSI in 2 lb increments
70 - 1200 kPa in 10 lb increments

AIR CHUCKS

Single Face Air Chuck

H1143

- Direct air line chuck with shut off valve built into chuck head
- Thread size: **1/4" NPT**

Single Face Air Chuck with Safety Clip

H1145

- Direct air line chuck with shut off valve built into chuck head
- Safety clip holds air chuck to valve stem
- Brass
- Air inlet (NPT) **1/4"**

Straight-On air Chuck with Safety Clip

H1144

- Direct air line chuck with shut off valve built into chuck head
- Safety clip holds air chuck to valve stem
- Brass
- Thread size **1/4" NPT female**

Dual Foot Air Chuck

H1301

- Direct air line chuck with shut off valve built into chuck head
- Thread size: **1/4" NPT**
- Overall length: **5-1/4"**

Dual Foot Air Chuck - Angle and Straight-On

H1302

- 30° angle & straight-on chuck with deep well lock
- Locks onto valve mouth when fitted
- Chrome plated finish
- Brass tube
- Air inlet (NPT) **1/4"**
- Overall length: **6-5/8"**

11 PC Pry Removal Tool Set

H3662

- Designed for the disassembly of door panels, dashboards, fascia, trim strips, bezels, window installation and more
- Specially constructed of impact resistant nylon
- It will not scratch or mar delicate surfaces like some metal versions
- Comes complete in a durable canvas storage roll pouch
- The pouch forms its own standing display or lays flat for easy access to tools while on the job
- Ideal for the automotive, marine, aviation and other industries where surface care is required



Set Includes :

- H3362-10** Angled clip panel remover
- H3362-11** Flat clip panel remover
- H3362-12** Panel remover
- H3362-13** Sharp panel remover
- H3362-19** Wide type remover
- H3362-14** Straight panel remover
- H3362-15** Clip panel remover
- H3362-16** Pull type remover
- H3362-17** Handy remover
- H3362-18** Narrow type remover
- H3362-20** Upholstery remover



5 PC Trim Panel Removal Set

H3664

- Variety of popular body trim panel removal tools
- Designed to prevent the trim panel fastener from pulling through the panel
- Ergonomic handle with SVCM satin chrome plated steel shafts
- Comes with a reusable storage tray

Set includes:

- **H3666** Large V Notch Tip, Length **9"**
- **H3668** Small V Notch Tip, Length **8-1/4"**
- **H3670** 1/4" U Notch Tip, Length **8-3/4"**
- **H3672** 5/16" U Notch Tip, Length **8-3/4"**
- **H3674** Square Notch Tip, Length **9-7/8"**

SVCM





CHROME SERIES GAUGES - PROFESSIONAL DUTY



HTA1106



HTA1109



HTA1118



HTA1125



HTA1136



HTA1150



HTA1153



HTA1154



HTA1156



HTA1216 (HTA1118, HTA1144)



HTA1308 (Includes HTA1106, HTA1118, HTA1144)

- All gauges are for 12 volt negative ground systems
- Accurate, reliable gauges, 2-1/16" dual SAE and metric dials
- Chrome bezels and panels with optional black vinyl decoration supplied
- White print and red pointers on black background. OEM backlit illuminated

Kit includes:

- Adapters and senders to fit most popular applications
- Full installation instructions
- OHMS rating for oil pressure gauges: 0 PSI = 225 - 259 OHMS, 50 PSI = 93 - 113 OHMS, 100 PSI = 30 - 38 OHMS
- OHMS rating for electrical temperature gauges: room temp = 1,730 OHMS, 130°F = 528 OHMS, 190°F = 165 OHMS, 290°F = 36 OHMS

PROD. NO.	Description	Range	Sweep	Includes
HTA1106	Ammeter	-60-0-60+	90°	-
HTA1109	Voltmeter	8-16 Volts	90°	-
HTA1118	Mechanical Water Temperature - 66° Capillary Tube	130° - 280°F 50° - 140°C	90°	1/2" and 3/8" NPT Adapters
HTA1125	Wide Sweep Mechanical Water Temperature - 66° Capillary Tube	130° - 280°F 50° - 140°C	270°	1/2" and 3/8" NPT Adapters 74" Lead
HTA1136	Electrical Water or Oil Temperature	130° - 280°F 50° - 140°C	90°	Sender Unit
HTA1144	Mechanical Oil Pressure	0-80 PSI	90°	72" Nylon Tube with Adapters
HTA1150	Wide Sweep Mechanical Oil Pressure	0-100 PSI	270°	72" Nylon Tube with Adapters
HTA1153	Electrical Oil Pressure	0-100 PSI	90°	Sender Unit
HTA1154	Manifold Vacuum	0-25 lb	270°	72" Plastic Tube with Adapters
HTA1156	Mechanical Water Temperature - 96° Capillary Tube	130° - 280°F 50° - 140°C	90°	1/2" and 3/8" NPT Adapters

PROD. NO.	Description
HTA1216	Dual Oil Pressure & Water Temperature Gauge Set
HTA1308	Triple Ammeter, Oil Pressure & Water Temperature Gauge Set

- Designed for heavier duty and marine applications
- Cross coil torque meter and oil dampened needle movements ensure steady readings
- Built with non-corrosive, durable plastic cases, with a water resistant seal and stainless steel bezels
- 2-1/16" diameter

Kit includes:

- Electric gauges
- 12 volt negative ground systems
- OEM backlit illuminated
- Mounting hardware and installation instructions (non connection wires)
- Clamshell packaging
- Sender thread 1/8 - 20 NPT

PROD. NO.	Description	Range	Sweep	Includes
HTA1000	Hour Meter - Rear Mount	0-99999.9	-	-
HTA1401	Electrical Oil Pressure	0-100 PSI	180°	Sender Unit
HTA1402	Electrical Water Temperature	100°-280°F	180°	Sender Unit
HTA1403	Voltmeter	8-16 volts	180°	-
HTA1404	Fuel Level Gauge	-	180°	-



HTA1401



HTA1000



HTA1402



HTA1404



HTA1403

EASY-READ GAUGE KITS WHITE FACE

- 2-1/16" dials
- OEM backlit illuminated
- SAE and metric readings
- Wide sweep for accurate readings
- Black deluxe panels and bezels
- For all 12 volt negative ground systems

Kit Includes:

- Adapters, installation hardware, instructions and lightening

PROD. NO.	Description	Range	Sweep	Includes
HTA1831	Mechanical Oil Pressure	0-100 PSI	270°	Sender Unit, 74" Lead
HTA1832	Ammeter	-60-0-60+	90°	-
HTA1833	Voltmeter	8-16 volts	90°	-
HTA1834	Mechanical Water Temperature	130°-280°F	270°	Sender Unit, 74" Lead
HTA1835	Triple Voltmeter, Water Temperature & Oil Pressure Gauge Set			



HTA1831



HTA1833



HTA1835 (Includes HTA1831, HTA1833, HTA1834)



HTA1832



HTA1834



HTA1820



HTA1819



HTA1830



TACHOMETERS

- 0-8,000 RPM
- 270° sweep
- Illuminated
- Red adjustable kit pointer
- All metal case
- Wide chrome plated bezel
- Heavy duty cross-coil meter
- 360° universal mounting
- Works on 12 volt conventional or electronic ignition systems
- For 4, 6 or 8 cylinder applications
- Hardware and instructions included

PROD. NO.	Size	Description
HTA1819	2" Dial Compact Tachometer	White Print and Red Pointer on Black Background
HTA1820	3-1/2" Dial Tachometer	White Print and Red Pointer on Black Background
HTA1830	Easy-Read 3 1/2" Dial Tachometer	Easy Read, Black Print and Pointer on White Background

ELECTRIC FUEL LEVEL GAUGE KIT

Electric Fuel Level Gauge Kit

HTA1117

- Adjustable. Fits tanks 5" to 27" in depth, right or left hand swing
- Gauge design appearance and size are the same as our standard chrome series gauges
- For 12 volt negative ground system

Kit Includes:

- Gauge, panel and sender
- OHMS rating:
Empty-240 OHMS
FULL-33 OHMS

HTA SERIES REPLACEMENT PARTS

PROD. NO.	Description
HTA1108A	12 Volt Bulb for all 2 1/16" Gauges
HTA1118A	1/2" adapter-Mech. Water Temp
HTA1118B	3/8" adapter-Mech. Water Temp.
HTA1136A	Metric Fittings - Mech. Temp. Gauges
HTA1136B	Sending Unit Kit Elect. Temp.
HTA1136C	1/8" x 1/4" adapter - Elect. Temp.
HTA1144A	Oil Press. Kit, 72" tube and adapters
HTA1144B	Oil Press. Kit, 144" tube and adapters
HTA1144C	5/16"F x 1/8" M Oil Pressure adapter
HTA1146A	Metric Fitting Kit
HTA1152A	Elect. Oil Press. Sender for HTA1153
HTA1312A	2-16" Chrome Single Gauge Panel Bezel
HTA1312B	2-16" Chrome Dual Gauge Panel Bezel
HTA1312C	2-16" Chrome Triple Gauge Panel Bezel



PRECISION/ ELECTRONIC MEASURING TOOLS



CALIPERS

- All JET calipers feature Stainless Steel construction for professional use

LCD Digital Calipers

- Four measurements – inside, outside, depth, step
- Extra large LCD screen is easier to read
- Professional quality hardened stainless steel construction
- Precision ground measuring surfaces
- With data output interface
- Fine adjustment thumb wheel
- Comes with high impact plastic storage case



310131

PROD. NO.	MOD. NO.	Type	Range	Increments
310131	JEDC-6	Electronic	0-6" (150 mm)	0.0005"/0.01 mm
310132	JEDC-8	Electronic	0-8" (200 mm)	0.0005"/0.01 mm
310136	JEDC-12	Electronic	0-12" (300 mm)	0.0005"/0.01 mm



310133

Four button control panel:

- power on/off switch (ON/OFF)
- zero setting at any position (ZERO)
- data hold function (HOLD)
- instant SAE / Metric conversion (MM/IN)

LCD Digital Calipers - Fractional

310133 /JEDC-6F

- Unique LCD can display measurements in Metric, SAE and fractional formats
- Easily converts measurements with the touch of a button
- Four measurements - inside, outside, depth, step
- Professional quality hardened stainless steel construction
- Precision ground measuring faces
- Auto power off
- Fine adjustment thumbwheel



Type	Range	Increments
Electronic	0-6" (150 mm)	0.0005" / 0.01 mm / 1/64"

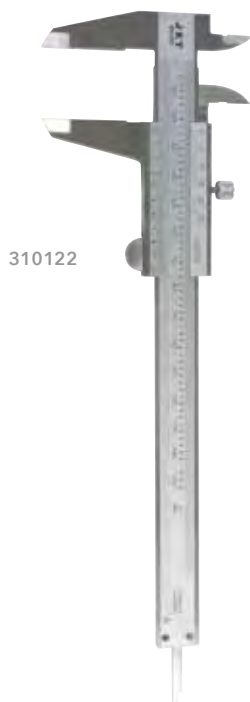

310122

Vernier Calipers

310122 /JVC-6

- Professional quality hardened stainless steel construction
- Four measurements – inside, outside, depth, step
- SAE scale
- Permanent abrasion resistant graduations
- Satin chrome finish
- Fine adjustment thumb wheel
- Screw lock mechanism

Type	Range	Increments
Vernier	0-6" (150 mm)	0.001"

Dial Indicator

310502 / JDI-1

- Knurled bezel rotates 360°
- Stainless steel rack and contact points
- Includes revolution counter
- Back lug of indicator can be swiveled 90° for easy clamping
- Easy to read white face dial
- Range 0 – 1", increments 0.001"
- Range per revolution 0.1"

Type	Range	Increments
Dial	0 - 1" (25 mm)	0.001"

LCD Digital Indicator

310501 / JEDI-1

- Large LCD display for easy reading
- Stainless steel rack and contact points
- With data output interface
- Automatic power off

Type	Range	Increments
Digital	0 - 1" (25 mm)	0.0005"/0.01mm



3 button control panel:

- zero setting at any position
- instant inch / metric conversion
- data hold / max-min tracking / fast display

MAGNETIC BASES

Standard Style

310902 / JMB-1

- Rod and swivel style
- On / Off switch to release magnet
- Powerful magnet holds base firmly to metal host
- 3 dimensional central locking mechanism
- Complete with fine adjustment
- Can be used with most makes of dial indicators

Flexible Style

310903 / JFMB-12

- 12" flexible arm holds dial indicator firmly in any position
- On / Off switch to release magnet
- Powerful magnet holds base firmly to metal host
- Stem flexes almost 360°

Quick Set Style

310905 / JMB-2

- Fine adjustment screw controls all 3 joints for fast set up
- On / Off switch to release magnet
- Powerful magnet holds base firmly to metal host





310206

Five button control panel:

- power on/off switch (ON/OFF)
- zero setting at any position (SET)
- instant SAE / Metric conversion (MM/IN)
- clock mode / data output
- absolute / incremental measurement (ABS/INC)



310210



310212



310223

MICROMETERS

LCD Digital Outside Micrometer

310206 / JEOM-1

- Large LCD display for easy reading
 - Precision machined carbide tipped measuring faces
 - Precision friction thimble for one hand operation
 - IP54 moisture resistant construction
 - Satin chrome finish – professional quality construction
 - 0 - 1" / 25mm range
 - 0.00005" / 0.001 mm increments
 - Comes with high impact custom plastic storage case
- Five button control panel:
 power on/off switch (ON/OFF), zero setting at any position (SET), instant SAE / Metric conversion (MM/IN), clock mode / data output, absolute / incremental measurement (ABS/INC)

3 OC Outside Micrometer Set

310210 / JOM-3S

- Precision machined carbide tipped measuring faces
- Precision ground and hardened one piece spindles
- Ratcheting friction stop provides uniform pressure
- Convenient lock holds spindle securely when transferring measurements
- 0.0001" increments
- Range: **0-3"**
- Contains 1 each of our **0 - 1"**, **1" - 2"**, and **2" - 3"** outside micrometers in a convenient custom made high impact plastic case
- Includes standards for both 1" - 2" and 2" - 3" models

Outside Micrometers - Open Stock

PROD. NO.	MOD. NO.	Type	Range	Increments
310211	JOM-1	Mechanical	0 - 1"	0.0001"
310212	JOM-2	Mechanical	1 - 2"	0.0001"
310213	JOM-3	Mechanical	2 - 3"	0.0001"

Depth Micrometer - Mechanical (0-6")

310223 / JDM-6

- Interchangeable extension rods feature precision lapped ends
- Ratcheting friction stop provides uniform pressure
- 4" precision ground hardened base
- 0.001" increments
- Satin chrome finish – professional quality construction
- Comes with high impact custom plastic storage case

Type	Range	Increments	Base Width
Mechanical	0 - 6"	0.001"	4"

Dial Bore (Cylinder) Gauge

310511 /JBG-6

- Used to measure the internal dimensions of work pieces such as cylinders, piping, tubing, etc.
- Allows cylinder wear measurements without removing pistons
- Unique guiding device that facilitates self centering
- Interchangeable extension anvils allow unit to measure a wide range of dimensions: SAE 2" - 6"
- Extremely accurate
- Measures bores up to 6" deep
- Easy to read white face dial
- Comes with high impact custom plastic storage case

Measuring Range	Maximum Depth	Number of Anvils	Increments
2" - 6"	6"	11	0.0005"



310511



- Four button control panel:**
- power on / off switch (ON/OFF)
 - zero setting at any position (SET)
 - instant SAE / Metric conversion (MM/IN)
 - data hold function (HOLD)

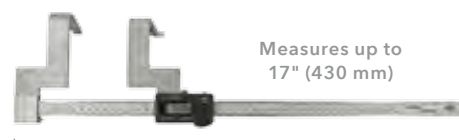
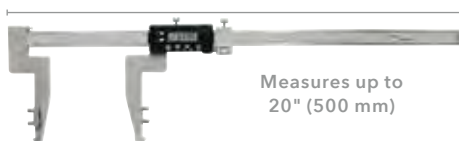

- Four button control panel:**
- power on / off switch (ON/OFF)
 - zero setting at any position (SET)
 - instant SAE / Metric conversion (MM/IN)
 - data hold

BRAKE AND ROTOR TOOLS

- All JET Brake and Rotor tools feature stainless steel construction for professional use

LCD Digital Disc Brake (Rotor) Caliper

310602 /JERG-1

- The ideal way to measure disc brake rotor thickness
- Both anvils are pointed to measure score depths
- With data output interface
- 0.0005" / 0.01 mm increments
- Comes with custom plastic case
- Range: **0 - 5"** (0 - 125 mm)
- Increments: 0.0005" / 0.01 mm

LCD Digital Drum Caliper

310604 /JEDG-1

- The ideal method to measure wear on brake drums
- 0 - 20" (500 mm) range
- With data output interface
- 0.0005" / 0.01 mm increments
- Comes with custom wood case
- Range: **0 - 20"** (0 - 500 mm)
- Increments: 0.0005" / 0.01 mm

LCD Digital Rotor Caliper (Wheel Stays On)

310603 /JERG-1WO

- For measuring disc brake rotor thickness without taking off the wheels
- Saves time and effort, increasing productivity
- All other features same as electronic rotor gauge (**310602**)
- 0 - 100 mm range
- Range: **0 - 4"** (0 - 100 mm)
- Increments: 0.0005" / 0.01 mm

LCD Digital Drum Caliper (Wheel Stays On)

310605 /JEDG-1WO

- For measuring wear on brake drums without taking the wheels off
- Saves time and effort, increasing productivity
- 0 - 17", 0 - 430 mm range
- 0.0005" / 0.01 mm increments
- Comes with custom wood case
- Range: **0 - 17"** (0 - 430 mm)
- Increments: 0.0005" / 0.01 mm

THERMOMETERS



If you are in the trades, we have the quality and performance you need to get the job done right.

Non-Contact Infrared

- Allows accurate measurement of temperature without contact
- Gives instant readouts in real time
- Ideal for use in inaccessible areas and where moving parts or high heat make contact measurement dangerous
- Thousands of uses including automotive applications, food and beverage industries, chemical industries, cement plants, road building, HVAC, pool maintenance, etc.

PROD. NO. MOD. NO.	310016 JIRT-450	310018 JIRT-750
Display	3-1/2 digit (1999 count) LCD with back lighting	3-1/2 digit (1999 count) LCD with back lighting
Measuring Range	-20°C to 450°C -4°F to 842°F	-50°C to 750°C -58°F to 1,382°F
Increments	1°C / °F	0.1°C / °F up to 200°C / °F 1°C / °F over 200°C / °F
Accuracy	+/- 2°C or 2% of reading	+/- 2°C or 1.5% of reading
Operating Temperature	0°C to 50°C / 32°F to 122°F	0°C to 50°C / 32°F to 122°F
Response Time	1 sec app.	1 sec app.
Field of View (Distance : Spot Size)	8:01	12:01
Spectral Response	6 - 14µm	8 - 14µm
Emissivity	0.95 fixed	0.95 fixed
Relative Humidity (Operating)	Max. 80%	10% - 90%
Over Range Indication	LCD will show "OVER" and meter will beep	LCD will show "1"
Power Off	Automatic shut-off after 7 sec.	Automatic shut-off after 7 sec.
Power Supply	9V battery	9V battery
Weight	180 gram	290 gram
Size	159 x 79 x 57.2 mm	100 x 56 x 230 mm



310018



310016



310006



310008

MULTIMETERS - DIGITAL

- Versatile meters for a wide range of electrical tests
- Features auto shut-off, large LCD display, low battery indicator, overload protection
- TPR shroud protects meter
- Can be used with clamp on adapter for expanded versatility
- Includes test leads, K-type thermo-coupler and 9V battery

Multimeter

- Designed to safety standard IEC-1010; CAT II 600V

PROD. NO. MOD. NO.	310006 JDMM-200
Application	AC/DC current AC/DC voltage resistance capacitance frequency temperature diode check transistor hFE
AC Current	20u-20m-200m-20A
DC Current	20m-200m-20A
AC Voltage	20-200-750V
DC Voltage	200m-2-20-200-1000V
Resistance	200-2k-20k-200k-2M-20M-200M ohms
Frequency	2k-20kHz
Diode Check	2.8V/1mA
Capacitance	2n-20n-200n-2u-20uF
Temperature	-40°C - 1000°C
hFE	Vce ~3V; 1b ~ 10Ua

Multimeter - Auto Ranging

- Automatically sets correct range when test function is selected
- Mechanically prevents incorrect connection of test leads
- Data hold function
- Designed to safety standard EN61010-1; CAT II 600V

PROD. NO. MOD. NO.	310008 JDMM-300
Application	AC/DC current AC/DC voltage resistance capacitance frequency temperature diode check duty cycle continuity check
AC Current	400u-4000u-40m-400m-4A-20A
DC Current	400u-4000u-40m-400m-4A-20A
AC Voltage	400mV-4V-40V-400V-750V
DC Voltage	400mV-4V-40V-400V-1000V
Resistance	200-4k-40k-400k-4M-40M ohms
Frequency	9.999Hz - 9.999MHz
Diode Check	Test current of 0.3mA, open circuit voltage of 1.5V
Duty Cycle	0.1% - 99.9%
Continuity Check	Threshold 30 ohms, continuity beeper 2.7 kHz
Capacitance	40nF-400nF-4uF-40uF-100uF
Temperature	-20°C - 760°C

Automotive Multimeter H3630

- Full-range - performs complete tune-up and troubleshooting tests on all vehicles
- Includes tests such as tach and dwell, test fuel injectors, sensors, alternators, spark plug wires, ignition and charging systems, battery condition and cranking voltage
- Easy-to-read digital LCD
- Data hold function
- Computer safe



Clamp Meter

- Takes measurements directly through clamp or with test leads
- Designed to safety standard IEC - 1010; CAT II 600V
- Includes zipper case, test leads and 9 volt battery

PROD. NO.	310022
MOD. NO.	JDCM-2
Application	AC/DC current AC/DC voltage resistance frequency
AC Current	4A - 1000A
DC Current	4A - 1000A
AC Voltage	750V
DC Voltage	1000V
Resistance	200 kOhms
Frequency	2kHz



Voltage Detector 310041 / JVD-600

- Non-contact detection of AC voltage from 100V to 600V
- Suitable for testing outlets or against cable insulation
- Flashing red LED and audible beep indicate voltage
- Built in LED flashlight and pocket clip
- Designed to safety standard CATIII 1,000V
- Always test on known live circuit before use







MECHANIC'S TOOLS



325



CHISEL POINT SCRAPERS

- Extra stiff stainless steel blades with chisel points for the toughest scraping and cleaning jobs
- Ergonomic handle provides non-slip grip and maximum user comfort
- Blades double-riveted to handles for maximum strength
- Steel striking cap for extra tough scraping jobs



859341

4 PC Chisel Point Scraper Set

859341 / JCS-4S

- 1-1/4" Scraper
- 1-1/4" Bent Scraper
- 2" Scraper
- 3/4" Stubby Scraper

Chisel Point Scrapers - Open Stock

PROD. NO.	MOD. NO.	Description	Blade Thickness
859342	JCS-125	1-1/4" Scraper	2.0mm
859343	JCS-125B	1-1/4" Bent Scraper	2.0mm
859344	JCS-200	2" Scraper	2.0mm
859345	JCS-2025	3/4" Stubby Scraper	2.5mm

- Exclusive ergonomic handle for maximum grip
- Premium grade Chrome Vanadium steel shafts
- Heat treated for maximum strength
- Heavy duty professional quality

5 PC Scraper Set

- Black Manganese Phosphate finish for corrosion resistance
- Precision ground edges

PROD. NO.	MOD. NO.	Length	Contents
859304	JPSS-5	1" x 8-1/2" 1/2" x 10" 1" x 12" 9" 7-1/2"	Short Scraper Medium Scraper Long Scraper Cotter Key Puller Radiator Hose Hook



859304

Hook Sets - Heavy Duty

- Nickel Chrome plated finish for corrosion resistance
- Extra long for maximum reach

PROD. NO.	MOD. NO.	Length	Pieces	Contents
859301	JPHS-604	6"	4	Straight Pick Bent Hook 90° Hook Compound Hook
859302	JPHS-904	9-3/4"	4	Straight Pick Bent Hook 90° Hook Compound Hook



859301

Open Stock

PROD. NO.	Length	Type	Contained in Set
859305	8-1/2"	1" Scraper	859304
859306	10"	1/2" Scraper	859304
859307	12"	1" Scraper	859304
859308	9"	Cotter Key Puller	859304
859309	7-1/2"	Radiator Hose Hook	859304
859310	6"	Straight Pick	859301
859311	6"	90° Pick	859301
859312	6"	Compound Hook	859301
859313	6"	Bent Hook	859301
859314	9-3/4"	Straight Pick	859302
859315	9-3/4"	90° Pick	859302
859316	9-3/4"	Compound Hook	859302
859317	9-3/4"	Bent Hook	859302



859302



PRY BARS - HEAVY DUTY

- Chrome Molybdenum steel for maximum strength
- Super large sizes for the heaviest duty applications
- Extra large bi-material handles provide exceptional grip and comfort and allow the use of both hands for maximum leverage
- "Go-thru" shanks with steel end caps
- Available separately or in 4 piece sets

4 PC Cushion Grip Set

779220 / JMPB-4S

- Regular Length: **8" - 25°, 12" - 25°, 18" - 25°, 24" - 25°**

CrMo

4 PC Jumbo Cushion Grip Set

779240 / JHPB-4S

- Jumbo length: **24" - 70°, 24" - 90°, 36" - 25°, 36" - straight**
- Blow mould case

CrMo



Extra large bi-material handles

Cushion Grip Type - Open Stock

PROD. NO.	MOD. NO.	Description	Type	Contained in Set
779221	JMPB-8	8" - 25°	Regular	779220
779222	JMPB-12	12" - 25°	Regular	779220
779223	JMPB-18	18" - 25°	Regular	779220
779224	JMPB-24	24" - 25°	Regular	779220

Jumbo Cushion Grip Type - Open Stock

PROD. NO.	MOD. NO.	Description	Type	Contained in Set
779241	JHPB-2445	24" - 70° narrow face	Jumbo	779240
779242	JHPB-2490	24" - 90° wide face	Jumbo	779240
779243	JHPB-3645	36" - 25° wide face	Jumbo	779240
779244	JHPB-3600	36" - straight wide face	Jumbo	779240



Chrome Molybdenum Steel is stronger than CrV or Carbon Steel

4 PC Rolling Head Pry Bar Set 859211 / JRPB-4S

- Rounded head acts as a fulcrum to provide extra leverage
- Tapered point and round stock ideal for aligning parts through bolt holes
- Heat treated Chrome Vanadium steel for professional use
- Magnetic particle tested to ensure complete material integrity
- Electrostatic powder coat paint protects against corrosion
- Includes: **6, 12, 16, 20"**

CrV

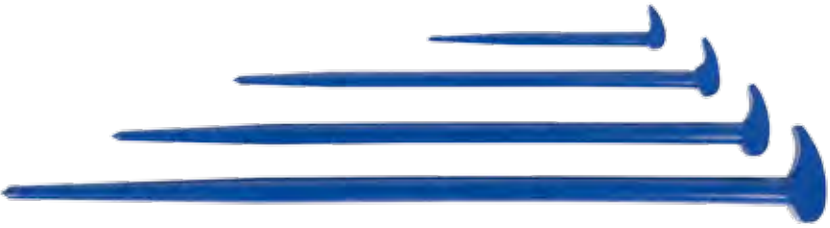

Rolling Head Pry Bars - Open Stock

PROD. NO.	Length	Contained in Set
859212	6"	859211
859213	12"	859211
859214	16"	859211
859215	20"	859211

CrV





POWERCLAW™

Chrome Molybdenum claw and mechanism tested up to 5 times ANSI standard for fixed head pry bars!



779279
Extendible Handle

PRY BARS - SUPER HEAVY DUTY



Indexible Pry Bars are fast becoming a "must have" tool in every mechanic's tool chest. The angle of the claw can be set and locked to provide the best possible leverage in any situation with just a single pry bar. JET takes this new technology to the next level with our exclusive Ratcheting Indexible Pry Bars. These unique tools provide all the benefits of Indexible Pry Bars PLUS the handle can be ratcheted back and forth. This allows the user to gain more leverage as the pried part is loosened without having to reposition the bar. Available only from JET!

3 PC POWERCLAW™ Ratcheting Indexible Pry Bar Set - Super Heavy Duty 779271/JRPB-3S

- Indexible claw locks in up to 8 positions for added torque
- Dual purpose lock button switches between indexed angle setting or ratcheting function
- Chrome Vanadium steel handle with Black Chrome finish for excellent corrosion resistance
- Set contains: **9, 12 and 15"**

Ratcheting Indexible Pry Bars - Open Stock

PROD. NO.	MOD. NO.	Length	Contained in Set
779274	JRPB-9	9"	779271
779275	JRPB-12	12"	779271
779276	JRPB-15	15"	779271
779277	JRPB-24	24"	-
779279	JRPB-1830	18 - 30" (Extendible Handle)	



Unique ratcheting mechanism allows handle to be ratcheted back and forth to gain additional leverage in extremely limited spaces

2 PC POWERCLAW™ Indexible Pry Bar Set - Super Heavy Duty

779266/JIPB-2

- Chrome Vanadium steel handle with Black Chrome finish for excellent corrosion resistance
- Set Contents: 1 each **8", 16"**
- Traditional non-ratcheting style

Indexible Pry Bars - Open Stock

PROD. NO.	MOD. NO.	Length	Contained in Set
779267	JIPB-8	8"	779266
779268	JIPB-16	16"	779266



Flush mount locking button minimizes head width for improved access



Chrome Molybdenum claw and mechanism tested up to 5 times ANSI standard for fixed head pry bars!



Indexible claw locks into any of 10 positions for improved leverage in confined spaces



MASTER TOOL KITS





549 PIECE MASTER TOOL KIT

699704 / MTK-549

Kit Count Product Description

1	10" Bastard Cut Flat File
2	8" Smooth Cut Flat File
3	10" Smooth Cut Flat File
4	8" Bastard Half Round File
5	10" Bastard Half Round File
6	10" Bastard Cut Mill File
7	10" Bastard Cut Round File
8	1/16" JET-KUT B&G Premium M2 H.S.S. Jobber Drill Bit
9	5/64" JET-KUT B&G Premium M2 H.S.S. Jobber Drill Bit
10	3/32" JET-KUT B&G Premium M2 H.S.S. Jobber Drill Bit
11	7/64" JET-KUT B&G Premium M2 H.S.S. Jobber Drill Bit
12	1/8" JET-KUT B&G Premium M2 H.S.S. Jobber Drill Bit
13	9/64" JET-KUT B&G Premium M2 H.S.S. Jobber Drill Bit
14	5/32" JET-KUT B&G Premium M2 H.S.S. Jobber Drill Bit
15	11/64" JET-KUT B&G Premium M2 H.S.S. Jobber Drill Bit
16	3/16" JET-KUT B&G Premium M2 H.S.S. Jobber Drill Bit
17	13/64" JET-KUT B&G Premium M2 H.S.S. Jobber Drill Bit
18	7/32" JET-KUT B&G Premium M2 H.S.S. Jobber Drill Bit
19	15/64" JET-KUT B&G Premium M2 H.S.S. Jobber Drill Bit
20	1/4" JET-KUT B&G Premium M2 H.S.S. Jobber Drill Bit
21	17/64" JET-KUT B&G Premium M2 H.S.S. Jobber Drill Bit
22	9/32" JET-KUT B&G Premium M2 H.S.S. Jobber Drill Bit
23	19/64" JET-KUT B&G Premium M2 H.S.S. Jobber Drill Bit
24	5/16" JET-KUT B&G Premium M2 H.S.S. Jobber Drill Bit
25	21/64" JET-KUT B&G Premium M2 H.S.S. Jobber Drill Bit
26	11/32" JET-KUT B&G Premium M2 H.S.S. Jobber Drill Bit
27	23/64" JET-KUT B&G Premium M2 H.S.S. Jobber Drill Bit
28	3/8" JET-KUT B&G Premium M2 H.S.S. Jobber Drill Bit
29	25/64" JET-KUT B&G Premium M2 H.S.S. Jobber Drill Bit
30	13/32" JET-KUT B&G Premium M2 H.S.S. Jobber Drill Bit
31	27/64" JET-KUT B&G Premium M2 H.S.S. Jobber Drill Bit
32	7/16" JET-KUT B&G Premium M2 H.S.S. Jobber Drill Bit
33	29/64" JET-KUT B&G Premium M2 H.S.S. Jobber Drill Bit
34	15/32" JET-KUT B&G Premium M2 H.S.S. Jobber Drill Bit
35	31/64" JET-KUT B&G Premium M2 H.S.S. Jobber Drill Bit
36	1/2" JET-KUT B&G Premium M2 H.S.S. Jobber Drill Bit
37	Metal Box with Drill Index
38	1/4" Dr x 3/16" 6 Point Socket
39	1/4" Dr x 7/32" 6 Point Socket
40	1/4" Dr x 1/4" 6 Point Socket
41	1/4" Dr x 9/32" 6 Point Socket
42	1/4" Dr x 5/16" 6 Point Socket
43	1/4" Dr x 11/32" 6 Point Socket
44	1/4" Dr x 3/8" 6 Point Socket
45	1/4" Dr x 7/16" 6 Point Socket
46	1/4" Dr x 1/2" 6 Point Socket
47	1/4" Dr x 3/16" 6 Point Deep Socket
48	1/4" Dr x 7/32" 6 Point Deep Socket
49	1/4" Dr x 1/4" 6 Point Deep Socket
50	1/4" Dr x 9/32" 6 Point Deep Socket
51	1/4" Dr x 5/16" 6 Point Deep Socket
52	1/4" Dr x 11/32" 6 Point Deep Socket
53	1/4" Dr x 3/8" 6 Point Deep Socket
54	1/4" Dr x 7/16" 6 Point Deep Socket
55	1/4" Dr x 1/2" 6 Point Deep Socket
56	1/4" Dr x 4mm 6 Point Socket
57	1/4" Dr x 5mm 6 Point Socket
58	1/4" Dr x 6mm 6 Point Socket
59	1/4" Dr x 7mm 6 Point Socket
60	1/4" Dr x 8mm 6 Point Socket
61	1/4" Dr x 9mm 6 Point Socket
62	1/4" Dr x 10mm 6 Point Socket
63	1/4" Dr x 11mm 6 Point Socket
64	1/4" Dr x 12mm 6 Point Socket
65	1/4" Dr x 4mm 6 Point Deep Socket
66	1/4" Dr x 5mm 6 Point Deep Socket
67	1/4" Dr x 6mm 6 Point Deep Socket
68	1/4" Dr x 7mm 6 Point Deep Socket
69	1/4" Dr x 8mm 6 Point Deep Socket
70	1/4" Dr x 9mm 6 Point Deep Socket
71	1/4" Dr x 10mm 6 Point Deep Socket



842563

42"
page 14

842513



Recommended tool boxes

842663

41"
page 18

842613



Kit Count Product Description

72	1/4" Dr x 11mm 6 Point Deep Socket
73	1/4" Dr x 12mm 6 Point Deep Socket
74	2" Extension
75	Universal Joint
76	6" Spinner Handle
77	4" Extension
78	1/4" Ratchet Handle
79	Blow Mould Case
80	3/8" Dr x 3/8" 6 Point Socket
81	3/8" Dr x 7/16" 6 Point Socket
82	3/8" Dr x 1/2" 6 Point Socket
83	3/8" Dr x 9/16" 6 Point Socket
84	3/8" Dr x 5/8" 6 Point Socket
83	3/8" Dr x 9/16" 6 Point Socket
84	3/8" Dr x 5/8" 6 Point Socket
85	3/8" Dr x 11/16" 6 Point Socket
86	3/8" Dr x 3/4" 6 Point Socket
87	3/8" Dr x 3/8" 6 Point Deep Socket
88	3/8" Dr x 7/16 6 Point Deep Socket
89	3/8" Dr x 1/2" 6 Point Deep Socket
90	3/8" Dr x 9/16" 6 Point Deep Socket
91	3/8" Dr x 5/8" 6 Point Deep Socket
92	3/8" Dr x 11/16" 6 Point Deep Socket
93	3/8" Dr x 3/4" 6 Point Deep Socket
94	3/8" Dr x 13/16" 6 Point Deep Socket

Kit Count Product Description

95	3/8" Dr x 8mm 6 Point Socket
96	3/8" Dr x 9mm 6 Point Socket
97	3/8" Dr x 10mm 6 Point Socket
98	3/8" Dr x 11mm 6 Point Socket
99	3/8" Dr x 12mm 6 Point Socket
100	3/8" Dr x 13mm 6 Point Socket
101	3/8" Dr x 14mm 6 Point Socket
102	3/8" Dr x 15mm 6 Point Socket
103	3/8" Dr x 16mm 6 Point Socket
104	3/8" Dr x 17mm 6 Point Socket
105	3/8" Dr x 18mm 6 Point Socket
106	3/8" Dr x 19mm 6 Point Socket
107	3/8" Dr x 8mm 6 Point Deep Socket
108	3/8" Dr x 9mm 6 Point Deep Socket
107	3/8" Dr x 8mm 6 Point Deep Socket
108	3/8" Dr x 9mm 6 Point Deep Socket
109	3/8" Dr x 10mm 6 Point Deep Socket
110	3/8" Dr x 11mm 6 Point Deep Socket
111	3/8" Dr x 12mm 6 Point Deep Socket
112	3/8" Dr x 13mm 6 Point Deep Socket
113	3/8" Dr x 14mm 6 Point Deep Socket
114	3/8" Dr x 15mm 6 Point Deep Socket
115	3/8" Dr x 16mm 6 Point Deep Socket
116	3/8" Dr x 17mm 6 Point Deep Socket
117	3/8" Dr x 18mm 6 Point Deep Socket

Tool storage not included with kit, see tool storage options

Kit Count	Product Description
118	3/8" Dr x 19mm 6 Point Deep Socket
119	Flex Handle
120	3" Extension
121	6" Extension
122	Universal Joint
123	High Torque Ratchet
124	Blow Mould Case
125	1/2" Dr - 3/8" 6 Point Socket
126	1/2" Dr x 7/16" 6 Point Socket
127	1/2" Dr x 1/2" 6 Point Socket
128	1/2" Dr x 9/16" 6 Point Socket
129	1/2" Dr x 5/8" 6 Point Socket Wrench
130	1/2" Dr x 11/16" 6 Point Socket Wrench
131	1/2" Dr x 3/4" 6 Point Socket
132	1/2" Dr x 13/16" 6 Point Socket
133	1/2" Dr x 7/8" 6 Point Socket
134	1/2" Dr x 15/16" 6 Point Socket
135	1/2" Dr x 1" 6 Point Socket
136	1/2" Dr x 1-1/16" 6 Point Socket
137	1/2" Dr x 1-1/8" 6 Point Socket
138	1/2" Dr x 1-3/16" 6 Point Socket
139	1/2" Dr x 1-1/4" 6 Point Socket
140	1/2" Dr x 7/16" 6 Point Deep Socket
141	1/2" Dr x 1/2" 6 Point Deep Socket
142	1/2" Dr x 9/16" 6 Point Deep Socket
143	1/2" Dr x 5/8" 6 Point Deep Socket
144	1/2" Dr x 11/16" 6 Point Deep Socket
145	1/2" Dr x 3/4" 6 Point Deep Socket
146	1/2" Dr x 7/8" 6 Point Deep Socket
147	1/2" Dr x 10mm 6 Point Socket
148	1/2" Dr x 11mm 6 Point Socket
149	1/2" Dr x 12mm 6 Point Socket
150	1/2" Dr x 13mm 6 Point Socket
151	1/2" Dr x 14mm 6 Point Socket
152	1/2" Dr x 15mm 6 Point Socket
153	1/2" Dr x 16mm 6 Point Socket
154	1/2" Dr x 17mm 6 Point Socket
155	1/2" Dr x 18mm 6 Point Socket
156	1/2" Dr x 19mm 6 Point Socket
157	1/2" Dr x 21mm 6 Point Socket
158	1/2" Dr x 22mm 6 Point Socket
159	1/2" Dr x 23mm 6 Point Socket
160	1/2" Dr x 24mm 6 Point Socket
161	1/2" Dr x 27mm 6 Point Socket
162	1/2" Dr x 30mm 6 Point Socket
163	1/2" Dr x 32mm 6 Point Socket
164	1/2" Dr x 10mm 6 Point Deep Socket
165	1/2" Dr x 12mm 6 Point Deep Socket
166	1/2" Dr x 13mm 6 Point Deep Socket
167	1/2" Dr x 14mm 6 Point Deep Socket
168	1/2" Dr x 15mm 6 Point Deep Socket
169	1/2" Dr x 16mm 6 Point Deep Socket
170	1/2" Dr x 17mm 6 Point Deep Socket
171	1/2" Dr x 18mm 6 Point Deep Socket
172	1/2" Dr x 19mm 6 Point Deep Socket
173	1/2" Dr x 21mm 6 Point Deep Socket
174	2" Extension
175	5" Extension
176	10" Extension
177	Sliding T Handle
178	Universal Joint
179	High Torque Ratchet
180	Blow Mould Case
181	3/8" Dr x E4 Torx Socket
182	3/8" Dr x E5 Torx Socket
183	3/8" Dr x E6 Torx Socket
184	3/8" Dr x E7 Torx Socket
185	3/8" Dr x E8 Torx Socket
186	3/8" Dr x E10 Torx Socket
187	3/8" Dr x E11 Torx Socket
188	3/8" Dr x E12 Torx Socket
189	3/8" Dr x E14 Torx Socket
190	3/8" Dr x E16 Torx Socket
191	3/8" Dr x E18 Torx Socket
192	3/8" Dr x E20 Torx Socket

Kit Count	Product Description
193	Socket Clip
194	1/2" Dr x 10mm 12 Point Socket
195	1/2" Dr x 11mm 12 Point Socket
196	1/2" Dr x 12mm 12 Point Socket
197	1/2" Dr x 13mm 12 Point Socket
198	1/2" Dr x 14mm 12 Point Socket
199	1/2" Dr x 15mm 12 Point Socket
200	1/2" Dr x 16mm 12 Point Socket
201	1/2" Dr x 17mm 12 Point Socket
202	1/2" Dr x 18mm 12 Point Socket
203	1/2" Dr x 19mm 12 Point Socket
204	1/2" Dr x 20mm 12 Point Socket
205	1/2" Dr x 21mm 12 Point Socket
206	1/2" Dr x 22mm 12 Point Socket
207	1/2" Dr x 24mm 12 Point Socket
208	Socket Clip
209	3/8" Dr x 1/8" Hex Key Socket
210	3/8" Dr x 5/32" Hex Key Socket
211	3/8" Dr x 3/16" Hex Key Socket
212	3/8" Dr x 7/32" Hex Key Socket
213	3/8" Dr x 1/4" Hex Key Socket
214	3/8" Dr x 5/16" Hex Key Socket
215	3/8" Dr x 3/8" Hex Key Socket
216	1/2" Dr x 1/2" Hex Key Socket
217	1/2" Dr x 9/16" Hex Key Socket
218	1/2" Dr x 5/8" Hex Key Socket
219	Socket Clip
220	3/8" Dr x 3mm Hex Key Socket
221	3/8" Dr x 4mm Hex Key Socket
222	3/8" Dr x 5mm Hex Key Socket
223	3/8" Dr x 6mm Hex Key Socket
224	3/8" Dr x 7mm Hex Key Socket
225	3/8" Dr x 8mm Hex Key Socket
226	3/8" Dr x 10mm Hex Key Socket
227	1/2" Dr x 12mm Hex Key Socket
228	1/2" Dr x 14mm Hex Key Socket
229	1/2" Dr x 16mm Hex Key Socket
230	Socket Clip
231	1/8" Extra Long Hex Bit Socket
232	5/32" Extra Long Hex Bit Socket
233	3/16" Extra Long Hex Bit Socket
234	7/32" Extra Long Hex Bit Socket
235	1/4" Extra Long Hex Bit Socket
236	5/16" Extra Long Hex Bit Socket
237	3/8" Extra Long Hex Bit Socket
238	Socket Clip
239	4mm Extra Long Hex Bit Socket
240	5mm Extra Long Hex Bit Socket
241	6mm Extra Long Hex Bit Socket
242	7mm Extra Long Hex Bit Socket
243	8mm Extra Long Hex Bit Socket
244	9mm Extra Long Hex Bit Socket
245	10mm Extra Long Hex Bit Socket
246	Socket Clip
247	1/4" Dr x T10 Torx Bit Socket
248	1/4" Dr x T15 Torx Bit Socket
249	1/4" Dr x T20 Torx Bit Socket
250	1/4" Dr x T25 Torx Bit Socket
251	1/4" Dr x T27 Torx Bit Socket
252	1/4" Dr x T30 Torx Bit Socket
253	3/8" Dr x T40 Torx Bit Socket
254	3/8" Dr x T45 Torx Bit Socket
255	3/8" Dr x T47 Torx Bit Socket
256	3/8" Dr x T50 Torx Bit Socket
257	3/8" Dr x T55 Torx Bit Socket
258	Socket Clip
259	1/4" Dr - 6" Spinner Handle
260	3/8" Dr - 16" Speeder Handle
261	3/8" Dr - 5/8" Spark Plug Socket
262	3/8" Dr - 13/16" Spark Plug Socket
263	1/2" Dr - 5" Flex Handle

Kit Count	Product Description
264	1/2" Dr - 16-1/2" Speeder Handle
265	1/2" Dr - 15" Extension Bar
266	1/2" Dr - 18" Extension Bar
267	1/2" Dr - 24" Extension Bar
268	1/2" Dr - 30" Extension Bar
269	3/8" Dr - 1-3/4" 2 Way Extension
270	3/8" Dr - 3" 2 Way Extension
271	3/8" Dr - 6" 2 Way Extension
272	3/8" Dr - 10" 2 Way Extension
273	3/8" Long Combination Wrench
274	7/16" Long Combination Wrench
275	1/2" Long Combination Wrench
276	9/16" Long Combination Wrench
277	5/8" Long Combination Wrench
278	11/16" Long Combination Wrench
279	3/4" Long Combination Wrench
280	13/16" Long Combination Wrench
281	7/8" Long Combination Wrench
282	15/16" Long Combination Wrench
283	1" Long Combination Wrench
284	1-1/16" Long Combination Wrench
285	1-1/8" Long Combination Wrench
286	1-1/4" Long Combination Wrench
287	Terylene Pouch
288	3/8" Stubby Combination Wrench
289	7/16" Stubby Combination Wrench
290	1/2" Stubby Combination Wrench
291	9/16" Stubby Combination Wrench
292	5/8" Stubby Combination Wrench
293	11/16" Stubby Combination Wrench
294	3/4" Stubby Combination Wrench
295	Plastic Rack
296	7mm Long Combination Wrench
297	8mm Long Combination Wrench
298	9mm Long Combination Wrench
299	10mm Long Combination Wrench
300	11mm Long Combination Wrench
301	12mm Long Combination Wrench
302	13mm Long Combination Wrench
303	14mm Long Combination Wrench
300	11mm Long Combination Wrench
301	12mm Long Combination Wrench
302	13mm Long Combination Wrench
303	14mm Long Combination Wrench
304	15mm Long Combination Wrench
305	16mm Long Combination Wrench
306	17mm Long Combination Wrench
307	18mm Long Combination Wrench
308	19mm Long Combination Wrench
309	21mm Long Combination Wrench
310	22mm Long Combination Wrench
311	24mm Long Combination Wrench
312	Terylene Pouch
313	10mm Stubby Combination Wrench
314	11mm Stubby Combination Wrench
315	12mm Stubby Combination Wrench
316	13mm Stubby Combination Wrench
317	14mm Stubby Combination Wrench
318	17mm Stubby Combination Wrench
319	19mm Stubby Combination Wrench
320	Plastic Rack
321	1/4" Ratcheting Combination Wrench
322	5/16" Ratcheting Combination Wrench
323	3/8" Ratcheting Combination Wrench
324	7/16" Ratcheting Combination Wrench
325	1/2" Ratcheting Combination Wrench
326	9/16" Ratcheting Combination Wrench
327	5/8" Ratcheting Combination Wrench
328	11/16" Ratcheting Combination Wrench
329	3/4" Ratcheting Combination Wrench
330	13/16" Ratcheting Combination Wrench
331	7/8" Ratcheting Combination Wrench
332	15/16" Ratcheting Combination Wrench



549 PIECE MASTER TOOL KIT

699704 / MTK-549

Kit Count Product Description

333	1" Ratcheting Combination Wrench
334	Plastic Rack
335	8mm Ratcheting Combination Wrench
336	9mm Ratcheting Combination Wrench
337	10mm Ratcheting Combination Wrench
338	11mm Ratcheting Combination Wrench
339	12mm Ratcheting Combination Wrench
340	13mm Ratcheting Combination Wrench
341	14mm Ratcheting Combination Wrench
342	15mm Ratcheting Combination Wrench
343	16mm Ratcheting Combination Wrench
344	17mm Ratcheting Combination Wrench
345	18mm Ratcheting Combination Wrench
346	19mm Ratcheting Combination Wrench
347	Plastic Rack
348	18" Aluminum Pipe Wrench
349	8" Professional Adjustable Wrench
350	12" Professional Adjustable Wrench
351	3/8" Dr Torque Wrench
352	1/2" Dr Torque Wrench
353	3/8" x 7/16" Flare Nut Wrench
354	1/2" x 9/16" Flare Nut Wrench
355	5/8" x 11/16" Flare Nut Wrench
356	10mm x 11mm Flare Nut Wrench
357	12mm x 13mm Flare Nut Wrench
358	15mm x 17mm Flare Nut Wrench
359	Phillips: #2 x 1-1/2" Jumbo Handle Screwdriver
360	Phillips: #1 x 3" Jumbo Handle Screwdriver
361	Phillips: #2 x 4" Jumbo Handle Screwdriver
362	Phillips: #3 x 6" Jumbo Handle Screwdriver
363	Square: #2 x 1-1/2" Jumbo Handle Screwdriver
364	Square: #1 x 4" Jumbo Handle Screwdriver
365	Square: #2 x 5" Jumbo Handle Screwdriver
366	Square: #3 x 6" Jumbo Handle Screwdriver
367	Slot Square Shaft: 1/4 x 1-1/2" Jumbo Handle Screwdriver
368	Slot Square Shaft: 1/4 x 4" Jumbo Handle Screwdriver
369	Slot Square Shaft: 5/16 x 6" Jumbo Handle Screwdriver
370	Slot Square Shaft: 3/8 x 10" Jumbo Handle Screwdriver
371	Slot Round Shaft: 3/16 x 3" Jumbo Handle Screwdriver
372	Slot Round Shaft: 3/16 x 6" Jumbo Handle Screwdriver
373	Blow Mould Case
374	2.0 Slot Precision Screwdriver
375	3.0 Slot Precision Screwdriver
376	4.0 Slot Precision Screwdriver
377	#00 Phillips Precision Screwdriver
378	#0 Phillips Precision Screwdriver
379	#1 Phillips Precision Screwdriver
380	Plastic Case
381	T5 Torx Precision Screwdriver
382	T6 Torx Precision Screwdriver
383	T7 Torx Precision Screwdriver
384	T8 Torx Precision Screwdriver
385	T9 Torx Precision Screwdriver
386	T10 Torx Precision Screwdriver
387	Plastic Case
388	Ratcheting Screwdriver Handle
389	1/8" Slot Bit for Ratcheting Screwdriver
390	#0 Phillips Bit for Ratcheting Screwdriver
391	3/16" Slot Bit for Ratcheting Screwdriver
392	#1 Phillips Bit for Ratcheting Screwdriver
393	1/4" Slot Bit for Ratcheting Screwdriver
394	#2 Phillips Bit for Ratcheting Screwdriver
395	5/16" Slot Bit for Ratcheting Screwdriver
396	#3 Phillips Bit for Ratcheting Screwdriver
397	#1 Square Bit for Ratcheting Screwdriver
398	#2 Square Bit for Ratcheting Screwdriver
399	T10 Torx Bit for Ratcheting Screwdriver
400	T15 Torx Bit for Ratcheting Screwdriver
401	T20 Torx Bit for Ratcheting Screwdriver
402	T25 Torx Bit for Ratcheting Screwdriver
403	1/8" Hex Bit for Ratcheting Screwdriver
404	3/16" Hex Bit for Ratcheting Screwdriver
405	Nut Driver for Ratcheting Screwdriver

Kit Count Product Description

406	Nut Driver for Ratcheting Screwdriver
407	Nut Driver for Ratcheting Screwdriver
408	5/16" Slotted Bit for Impact Driver
409	3/8" Slotted Bit for Impact Driver
410	#2 Phillips Bit for Impact Driver
411	#3 Phillips Bit for Impact Driver
412	Driver for Impact Driver
413	Adapter for Impact Driver
414	Plastic Case
415	3/16" Jumbo Handle Nut Driver
416	1/4" Jumbo Handle Nut Driver
417	5/16" Jumbo Handle Nut Driver
418	11/32" Jumbo Handle Nut Driver
419	3/8" Jumbo Handle Nut Driver
420	7/16" Jumbo Handle Nut Driver
421	1/2" Jumbo Handle Nut Driver
422	6" Slip Joint Pliers - Standard Duty
423	8" Slip Joint Pliers - Standard Duty
424	9-1/2" Groove Joint Plier - Chrome Vanadium
425	12" Groove Joint Plier - Chrome Vanadium
426	5" Curved Jaw Locking Pliers
427	4" Curved Jaw Locking Pliers
428	10" Curved Jaw Locking Pliers
429	6" Long Nose Locking Pliers
430	9" Long Nose Locking Pliers
431	8" Linesman's Pliers - Chrome Vanadium
432	8" Long Nose Pliers - Chrome Vanadium
433	1" Long Nose Pliers
434	7-1/2" Diagonal Cutter - Chrome Vanadium
435	6-1/2" Bent Nose Pliers
436	8" Bent Nose Pliers
437	11" C-Clamp and Pads
438	Wire Stripper
439	Straight Cut Aviation Metal Snips
440	Telescopic Tube Cutter
441	Mini Tubing Cutter
442	Screw Feed Tubing Cutter for Flaring Tool Kit
443	Flaring Bar for Flaring Tool Kit
444	Yoke for Flaring Tool Kit
445	3/16" Flaring Insert for Flaring Tool Kit
446	1/4" Flaring Insert for Flaring Tool Kit
447	5/16" Flaring Insert for Flaring Tool Kit
448	3/8" Flaring Insert for Flaring Tool Kit
449	7/16" Flaring Insert for Flaring Tool Kit
450	1/2" Flaring Insert for Flaring Tool Kit
451	5/8" Flaring Insert for Flaring Tool Kit
452	Blow Mould Case
453	8oz Ball Pein Fibreglass Hammer
454	16oz Ball Pein Fibreglass Hammer
455	24oz Ball Pein Fibreglass Hammer
456	32oz Ball Pein Fibreglass Hammer
457	40oz Ball Pein Fibreglass Hammer
458	2 lb Dead Blow Hammer
459	3 lb Dead Blow Hammer
460	2-1/4 lb Soft Face Dead Blow Hammer
461	3 lb Drilling Hammer
462	3" 2/3 Jaw Gear Puller
463	0.05" Long Arm Ball Nose Hex Key
464	1/16" Long Arm Ball Nose Hex Key
465	5/64" Long Arm Ball Nose Hex Key
466	3/32" Long Arm Ball Nose Hex Key
467	7/64" Long Arm Ball Nose Hex Key
468	1/8" Long Arm Ball Nose Hex Key
469	9/64" Long Arm Ball Nose Hex Key
470	5/32" Long Arm Ball Nose Hex Key
471	3/16" Long Arm Ball Nose Hex Key
472	7/32" Long Arm Ball Nose Hex Key
473	1/4" Long Arm Ball Nose Hex Key
474	5/16" Long Arm Ball Nose Hex Key
475	3/8" Long Arm Ball Nose Hex Key
476	1.5mm Long Arm Ball Nose Hex Key
477	2.0mm Long Arm Ball Nose Hex Key
478	2.5mm Long Arm Ball Nose Hex Key

Kit Count Product Description

479	3.0mm Long Arm Ball Nose Hex Key
480	4.0mm Long Arm Ball Nose Hex Key
481	5.0mm Long Arm Ball Nose Hex Key
482	6.0mm Long Arm Ball Nose Hex Key
483	8.0mm Long Arm Ball Nose Hex Key
484	10mm Long Arm Ball Nose Hex Key
485	Plastic Rack
486	T8 Torx Key
487	T10 Torx Key
488	T15 Torx Key
489	T20 Torx Key
490	T25 Torx Key
491	T27 Torx Key
492	T30 Torx Key
493	T40 Torx Key
494	12" Hacksaw Frame
495	1/16" Pin Punch
496	3/32" Pin Punch
497	1/8" Pin Punch
498	5/32" Pin Punch
499	3/16" Pin Punch
500	1/4" Pin Punch
501	5/16" Pin Punch
502	1/16" Solid Punch
503	1/8" Solid Punch
504	3/16" Solid Punch
505	1/4" Solid Punch
506	5/16" Solid Punch
507	5/32" Solid Punch
508	1/4" Cold Chisel
509	5/16" Cold Chisel
510	1/2" Cold Chisel
511	5/8" Cold Chisel
512	3/4" Cold Chisel
513	7/8" Cold Chisel
514	3/8" Cold Chisel
515	5/64" Centre Punch
516	5/32" Centre Punch
517	1/4" Centre Punch
518	Automatic Centre Punch
519	Terylene Pouch
520	3/32" Roll Pin Punch
521	1/8" Roll Pin Pinch
522	5/32" Roll Pin Punch
523	3/16" Roll Pin Punch
524	1/4" Roll Pin Punch
525	5/16" Roll Pin Punch
526	Terylene Pouch
527	25ft Tape Measure
528	8" Mechanic's Pry Bar
529	12" Mechanic's Pry Bar
530	18" Mechanic's Pry Bar
531	24" Mechanic's Pry Bar
532	6" Straight Pick
533	6" 90 Pick
534	6" Compound Hook
535	6" Bent Hook
536	8-1/2" Scraper
537	10" Scraper
538	12" Scraper
539	9" Cotter Key Puller
540	7-1/2" Radiator Hose Hook
541	1-1/4" Chisel Scraper
542	1-1/4" Bent Chisel Scraper
543	2" Chisel Scraper
544	Stubby Chisel Scraper
545	1/4"-5/16" Screw Extractor
546	3/8" Screw Extractor
547	7/16" Screw Extractor
548	1/2"-9/16" Screw Extractor
549	5/8" Screw Extractor

306 PIECE INTERMEDIATE TOOL KIT

699703 / MIK-306



Recommended tool boxes



842563

42"
page 14

842513



842663

41"
page 18

842613



842553

27"
page 13

842503



842653

27"
page 16

842604

Kit Count	Product Description
1	1/16" JET-KUT Black Oxide H.S.S. Jobber Drill Bit
2	5/64" JET-KUT Black Oxide H.S.S. Jobber Drill Bit
3	3/32" JET-KUT Black Oxide H.S.S. Jobber Drill Bit
4	7/64" JET-KUT Black Oxide H.S.S. Jobber Drill Bit
5	1/8" JET-KUT Black Oxide H.S.S. Jobber Drill Bit
6	9/64" JET-KUT Black Oxide H.S.S. Jobber Drill Bit
7	5/32" JET-KUT Black Oxide H.S.S. Jobber Drill Bit
8	11/64" JET-KUT Black Oxide H.S.S. Jobber Drill Bit
9	3/16" JET-KUT Black Oxide H.S.S. Jobber Drill Bit
10	13/64" JET-KUT Black Oxide H.S.S. Jobber Drill Bit
11	7/32" JET-KUT Black Oxide H.S.S. Jobber Drill Bit
12	15/64" JET-KUT Black Oxide H.S.S. Jobber Drill Bit
13	1/4" JET-KUT Black Oxide H.S.S. Jobber Drill Bit
14	17/64" JET-KUT Black Oxide H.S.S. Jobber Drill Bit
15	9/32" JET-KUT Black Oxide H.S.S. Jobber Drill Bit
16	19/64" JET-KUT Black Oxide H.S.S. Jobber Drill Bit
17	5/16" JET-KUT Black Oxide H.S.S. Jobber Drill Bit
18	21/64" JET-KUT Black Oxide H.S.S. Jobber Drill Bit
19	11/32" JET-KUT Black Oxide H.S.S. Jobber Drill Bit
20	23/64" JET-KUT Black Oxide H.S.S. Jobber Drill Bit
21	3/8" JET-KUT Black Oxide H.S.S. Jobber Drill Bit
22	25/64" JET-KUT Black Oxide H.S.S. Jobber Drill Bit
23	13/32" JET-KUT Black Oxide H.S.S. Jobber Drill Bit
24	27/64" JET-KUT Black Oxide H.S.S. Jobber Drill Bit
25	7/16" JET-KUT Black Oxide H.S.S. Jobber Drill Bit
26	29/64" JET-KUT Black Oxide H.S.S. Jobber Drill Bit
27	15/32" JET-KUT Black Oxide H.S.S. Jobber Drill Bit
28	31/64" JET-KUT Black Oxide H.S.S. Jobber Drill Bit

Kit Count	Product Description
29	1/2" JET-KUT Black Oxide H.S.S. Jobber Drill Bit
30	Metal Box with Drill Index
31	1/4" Dr x 3/16" 6 Point Socket
32	1/4" Dr x 7/32" 6 Point Socket
33	1/4" Dr x 1/4" 6 Point Socket
34	1/4" Dr x 9/32" 6 Point Socket
35	1/4" Dr x 5/16" 6 Point Socket
36	1/4" Dr x 11/32" 6 Point Socket
37	1/4" Dr x 3/8" 6 Point Socket
38	1/4" Dr x 7/16" 6 Point Socket
39	1/4" Dr x 1/2" 6 Point Socket
40	1/4" Dr x 3/16" 6 Point Deep Socket
41	1/4" Dr x 7/32" 6 Point Deep Socket
42	1/4" Dr x 1/4" 6 Point Deep Socket
43	1/4" Dr x 9/32" 6 Point Deep Socket
44	1/4" Dr x 5/16" 6 Point Deep Socket
45	1/4" Dr x 11/32" 6 Point Deep Socket
46	1/4" Dr x 3/8" 6 Point Deep Socket
46	1/4" Dr x 3/8" 6 Point Deep Socket
47	1/4" Dr x 7/16" 6 Point Deep Socket
48	1/4" Dr x 11/32" 6 Point Deep Socket
49	1/4" Dr x 3/8" 6 Point Deep Socket
49	1/4" Dr x 3/8" 6 Point Deep Socket
50	1/4" Dr x 1/2" 6 Point Deep Socket
51	1/4" Dr x 4mm 6 Point Socket
50	1/4" Dr x 5mm 6 Point Socket
51	1/4" Dr x 6mm 6 Point Socket
52	1/4" Dr x 7mm 6 Point Socket
53	1/4" Dr x 8mm 6 Point Socket
54	1/4" Dr x 9mm 6 Point Socket
55	1/4" Dr x 10mm 6 Point Socket

Kit Count	Product Description
56	1/4" Dr x 11mm 6 Point Socket
57	1/4" Dr x 12mm 6 Point Socket
58	1/4" Dr x 4mm 6 Point Deep Socket
59	1/4" Dr x 5mm 6 Point Deep Socket
60	1/4" Dr x 6mm 6 Point Deep Socket
61	1/4" Dr x 7mm 6 Point Deep Socket
62	1/4" Dr x 8mm 6 Point Deep Socket
63	1/4" Dr x 9mm 6 Point Deep Socket
64	1/4" Dr x 10mm 6 Point Deep Socket
65	1/4" Dr x 11mm 6 Point Deep Socket
66	1/4" Dr x 12mm 6 Point Deep Socket
67	2" Extension
68	Universal Joint
69	6" Spinner Handle
70	4" Extension
71	1/4" Ratchet Handle
72	Blow Mould Case
73	3/8" Dr x 3/8" 6 Point Socket
74	3/8" Dr x 7/16" 6 Point Socket
75	3/8" Dr x 1/2" 6 Point Socket
76	3/8" Dr x 9/16" 6 Point Socket
77	3/8" Dr x 5/8" 6 Point Socket
78	3/8" Dr x 11/16" 6 Point Socket
79	3/8" Dr x 3/4" 6 Point Socket
80	3/8" Dr x 3/8" 6 Point Deep Socket
81	3/8" Dr x 7/16" 6 Point Deep Socket
82	3/8" Dr x 1/2" 6 Point Deep Socket
83	3/8" Dr x 9/16" 6 Point Deep Socket

Tool storage not included with kit, see tool storage options



306 PIECE INTERMEDIATE TOOL KIT

699703 / MIK-306

Kit Count Product Description

84	3/8" Dr x 5/8" 6 Point Deep Socket
85	3/8" Dr x 11/16" 6 Point Deep Socket
86	3/8" Dr x 3/4" 6 Point Deep Socket
87	3/8" Dr x 13/16" 6 Point Deep Socket
88	3/8" Dr x 8mm 6 Point Socket
89	3/8" Dr x 9mm 6 Point Socket
90	3/8" Dr x 10mm 6 Point Socket
91	3/8" Dr x 11mm 6 Point Socket
92	3/8" Dr x 12mm 6 Point Socket
93	3/8" Dr x 13mm 6 Point Socket
94	3/8" Dr x 14mm 6 Point Socket
95	3/8" Dr x 15mm 6 Point Socket
96	3/8" Dr x 16mm 6 Point Socket
97	3/8" Dr x 17mm 6 Point Socket
98	3/8" Dr x 18mm 6 Point Socket
99	3/8" Dr x 19mm 6 Point Socket
100	3/8" Dr x 8mm 6 Point Deep Socket
101	3/8" Dr x 9mm 6 Point Deep Socket
102	3/8" Dr x 10mm 6 Point Deep Socket
103	3/8" Dr x 11mm 6 Point Deep Socket
104	3/8" Dr x 12mm 6 Point Deep Socket
105	3/8" Dr x 13mm 6 Point Deep Socket
106	3/8" Dr x 14mm 6 Point Deep Socket
107	3/8" Dr x 15mm 6 Point Deep Socket
108	3/8" Dr x 16mm 6 Point Deep Socket
109	3/8" Dr x 17mm 6 Point Deep Socket
110	3/8" Dr x 18mm 6 Point Deep Socket
111	3/8" Dr x 19mm 6 Point Deep Socket
112	Flex Handle
113	3" Extension
114	6" Extension
115	Universal Joint
116	High Torque Ratchet
117	Blow Mould Case
118	1/8" Hex Bit Socket
119	5/32" Hex Bit Socket
120	3/16" Hex Bit Socket
121	7/32" Hex Bit Socket
122	1/4" Hex Bit Socket
123	5/16" Hex Bit Socket
124	3/8" Hex Bit Socket
125	Socket Clip
126	3/8" Dr x 3mm Hex Bit Socket
127	3/8" Dr x 4mm Hex Bit Socket
128	3/8" Dr x 5mm Hex Bit Socket
129	3/8" Dr x 6mm Hex Bit Socket
130	3/8" Dr x 7mm Hex Bit Socket
131	3/8" Dr x 8mm Hex Bit Socket
132	3/8" Dr x 10mm Hex Bit Socket
133	Socket Clip
134	1/4" Dr x T10 Tamperproof Torx Bit Socket
135	1/4" Dr x T15 Tamperproof Torx Bit Socket
136	1/4" Dr x T20 Tamperproof Torx Bit Socket
137	1/4" Dr x T25 Tamperproof Torx Bit Socket
138	1/4" Dr x T27 Tamperproof Torx Bit Socket
139	1/4" Dr x T30 Tamperproof Torx Bit Socket
140	3/8" Dr x T40 Tamperproof Torx Bit Socket
141	3/8" Dr x T45 Tamperproof Torx Bit Socket
142	3/8" Dr x T50 Tamperproof Torx Bit Socket
143	3/8" Dr x T55 Tamperproof Torx Bit Socket
144	Socket Clip
145	6" Flex Handle
146	3/8" Dr - 5/8" Spark Plug Socket
147	3/8" Dr - 13/16" Spark Plug Socket
148	3/8" Long Combination Wrench
149	7/16" Long Combination Wrench
150	1/2" Long Combination Wrench
151	9/16" Long Combination Wrench
152	5/8" Long Combination Wrench
153	11/16" Long Combination Wrench
154	3/4" Long Combination Wrench
155	13/16" Long Combination Wrench
156	7/8" Long Combination Wrench

Kit Count Product Description

157	15/16" Long Combination Wrench
158	1" Long Combination Wrench
159	1-1/16" Long Combination Wrench
160	1-1/8" Long Combination Wrench
161	1-1/4" Long Combination Wrench
162	Terylene Pouch
163	7mm Long Combination Wrench
164	8mm Long Combination Wrench
165	9mm Long Combination Wrench
166	10mm Long Combination Wrench
167	11mm Long Combination Wrench
168	12mm Long Combination Wrench
169	13mm Long Combination Wrench
170	14mm Long Combination Wrench
171	15mm Long Combination Wrench
172	16mm Long Combination Wrench
173	17mm Long Combination Wrench
174	18mm Long Combination Wrench
175	19mm Long Combination Wrench
176	21mm Long Combination Wrench
177	22mm Long Combination Wrench
178	24mm Long Combination Wrench
179	Terylene Pouch
180	8mm Ratcheting Combination Wrench
181	10mm Ratcheting Combination Wrench
182	12mm Ratcheting Combination Wrench
183	13mm Ratcheting Combination Wrench
184	14mm Ratcheting Combination Wrench
185	15mm Ratcheting Combination Wrench
186	18mm Ratcheting Combination Wrench
187	Plastic Rack
188	5/16" Ratcheting Combination Wrench
189	3/8" Ratcheting Combination Wrench
190	7/16" Ratcheting Combination Wrench
191	1/2" Ratcheting Combination Wrench
192	9/16" Ratcheting Combination Wrench
193	5/8" Ratcheting Combination Wrench
194	11/16" Ratcheting Combination Wrench
195	3/4" Ratcheting Combination Wrench
196	Plastic Rack
197	10" Professional Adjustable Wrench
198	T10 x 4" Torx Mechanic's Screwdriver
199	T15 x 4" Torx Mechanic's Screwdriver
200	T20 x 4" Torx Mechanic's Screwdriver
201	T25 x 4" Torx Mechanic's Screwdriver
202	T27 x 4" Torx Mechanic's Screwdriver
203	T30 x 4" Torx Mechanic's Screwdriver
204	Slot: 1/4 x 1-1/2" Mechanic's Screwdriver
205	Slot: 1/4 x 4" Mechanic's Screwdriver
206	Slot: 5/16 x 6" Mechanic's Screwdriver
207	Slot: 3/8 x 10" Mechanic's Screwdriver
208	Phillips: #1 x 3" Mechanic's Screwdriver
209	Phillips: #2 x 1-1/2" Mechanic's Screwdriver
210	Phillips: #2 x 4" Mechanic's Screwdriver
211	Blow Mould Case
212	2.0 Slot Precision Screwdriver
213	3.0 Slot Precision Screwdriver
214	4.0 Slot Precision Screwdriver
215	#00 Phillips Precision Screwdriver
216	#0 Phillips Precision Screwdriver
217	#1 Phillips Precision Screwdriver
218	Plastic Case
219	T5 Torx Precision Screwdriver
220	T6 Torx Precision Screwdriver
221	T7 Torx Precision Screwdriver
222	T8 Torx Precision Screwdriver
223	T9 Torx Precision Screwdriver
224	T10 Torx Precision Screwdriver
225	Plastic Case
226	Ratcheting Screwdriver Handle
227	1/8" Slot Bit for Ratcheting Screwdriver
228	#0 Phillips Bit for Ratcheting Screwdriver
229	3/16" Slot Bit for Ratcheting Screwdriver
230	#1 Phillips Bit for Ratcheting Screwdriver
231	1/4" Slot Bit for Ratcheting Screwdriver

Kit Count Product Description

232	#2 Phillips Bit for Ratcheting Screwdriver
233	5/16" Slot Bit for Ratcheting Screwdriver
234	#3 Phillips Bit for Ratcheting Screwdriver
235	#1 Square Bit for Ratcheting Screwdriver
236	#2 Square Bit for Ratcheting Screwdriver
237	T10 Torx Bit for Ratcheting Screwdriver
238	T15 Torx Bit for Ratcheting Screwdriver
239	T20 Torx Bit for Ratcheting Screwdriver
240	T25 Torx Bit for Ratcheting Screwdriver
241	1/8" Hex Bit for Ratcheting Screwdriver
242	3/16" Hex Bit for Ratcheting Screwdriver
243	1/4" Nut Driver for Ratcheting Screwdriver
244	5/16" Nut Driver for Ratcheting Screwdriver
245	7/16" Nut Driver for Ratcheting Screwdriver
246	8" Slip Joint Pliers
247	6-1/2" Long Nose Pliers
248	6-1/2" Diagonal Cutter
249	9-1/2" Groove Joint Pliers
250	10" Curved Jaw Locking Pliers
251	9" Multifunction Wire Stripper
252	Straight Cut Aviation Metal Snips
253	Telescopic Tube Cutter
254	1lb Rubber Mallet
255	1.5mm Short Arm Hex Key
256	2.0mm Short Arm Hex Key
257	2.5mm Short Arm Hex Key
258	3.0mm Short Arm Hex Key
259	4.0mm Short Arm Hex Key
260	4.5mm Short Arm Hex Key
261	5.0mm Short Arm Hex Key
262	5.5mm Short Arm Hex Key
263	6.0mm Short Arm Hex Key
264	7.0mm Short Arm Hex Key
265	8.0mm Short Arm Hex Key
266	9.0mm Short Arm Hex Key
267	10.0mm Short Arm Hex Key
268	1/16" Long Arm Hex Key
269	5/64" Long Arm Hex Key
270	3/32" Long Arm Hex Key
271	7/64" Long Arm Hex Key
272	1/8" Long Arm Hex Key
273	9/64" Long Arm Hex Key
274	5/32" Long Arm Hex Key
275	3/16" Long Arm Hex Key
276	7/32" Long Arm Hex Key
277	1/4" Long Arm Hex Key
278	5/16" Long Arm Hex Key
279	3/8" Long Arm Hex Key
280	Plastic Rack
281	1/8" Pin Punch
282	3/16" Pin Punch
283	1/4" Pin Punch
284	3/16" Solid Punch
285	1/2" Cold Chisel
286	5/8" Cold Chisel
287	3/4" Cold Chisel
288	5/32" Centre Punch
289	Terylene Pouch
290	16ft Tape Measure
291	8" Mechanic's Pry Bar
292	12" Mechanic's Pry Bar
293	18" Mechanic's Pry Bar
294	24" Mechanic's Pry Bar
295	1" Short Scraper
296	Parts Cleaning Brush
297	6-12 Volt Circuit Tester
298	Long Telescoping Magnet
299	Mechanic's Stethoscope
300	1/8" - 1/4" Screw Extractor
301	1/4" - 5/16" Screw Extractor
302	5/16" - 7/16" Screw Extractor
303	7/16" - 9/16" Screw Extractor
304	9/16" - 3/4" Screw Extractor
305	Tie Rod End Puller
306	4-Battery Post and Terminal Clean

211 PIECE MECHANIC'S STARTER TOOL KIT
699702 / STK-211



842652
Included with kit





211 PIECE MECHANIC'S STARTER TOOL KIT

699702 / STK-211

Kit Count Product Description

1	1/4" Dr x 3/16" 6 Point Socket
2	1/4" Dr x 7/32" 6 Point Socket
3	1/4" Dr x 1/4" 6 Point Socket
4	1/4" Dr x 9/32" 6 Point Socket
5	1/4" Dr x 5/16" 6 Point Socket
6	1/4" Dr x 11/32" 6 Point Socket
7	1/4" Dr x 3/8" 6 Point Socket
8	1/4" Dr x 7/16" 6 Point Socket
9	1/4" Dr x 1/2" 6 Point Socket
10	1/4" Dr x 3/16" 6 Point Deep Socket
11	1/4" Dr x 7/32" 6 Point Deep Socket
12	1/4" Dr x 1/4" 6 Point Deep Socket
13	1/4" Dr x 9/32" 6 Point Deep Socket
14	1/4" Dr x 5/16" 6 Point Deep Socket
15	1/4" Dr x 11/32" 6 Point Deep Socket
16	1/4" Dr x 3/8" 6 Point Deep Socket
17	1/4" Dr x 7/16" 6 Point Deep Socket
18	1/4" Dr x 1/2" 6 Point Deep Socket
19	1/4" Dr x 4mm 6 Point Socket
20	1/4" Dr x 5mm 6 Point Socket
21	1/4" Dr x 6mm 6 Point Socket
22	1/4" Dr x 7mm 6 Point Socket
23	1/4" Dr x 8mm 6 Point Socket
24	1/4" Dr x 9mm 6 Point Socket
25	1/4" Dr x 10mm 6 Point Socket
26	1/4" Dr x 11mm 6 Point Socket
27	1/4" Dr x 12mm 6 Point Socket
28	1/4" Dr x 4mm 6 Point Deep Socket
29	1/4" Dr x 5mm 6 Point Deep Socket
30	1/4" Dr x 6mm 6 Point Deep Socket
31	1/4" Dr x 7mm 6 Point Deep Socket
32	1/4" Dr x 8mm 6 Point Deep Socket
33	1/4" Dr x 9mm 6 Point Deep Socket
34	1/4" Dr x 10mm 6 Point Deep Socket
35	1/4" Dr x 11mm 6 Point Deep Socket
36	1/4" Dr x 12mm 6 Point Deep Socket
37	2" Extension
38	Universal Joint
39	6" Spinner Handle
40	4" Extension
41	1/4" Ratchet Handle
42	Blow Mould Case
43	3/8" Dr x 3/8" 6 Point Socket
44	3/8" Dr x 7/16" 6 Point Socket
45	3/8" Dr x 1/2" 6 Point Socket
46	3/8" Dr x 9/16" 6 Point Socket
47	3/8" Dr x 5/8" 6 Point Socket
48	3/8" Dr x 11/16" 6 Point Socket
49	3/8" Dr x 3/4" 6 Point Socket
50	3/8" Dr x 3/8" 6 Point Deep Socket
51	3/8" Dr x 7/16" 6 Point Deep Socket
52	3/8" Dr x 1/2" 6 Point Deep Socket
53	3/8" Dr x 9/16" 6 Point Deep Socket
54	3/8" Dr x 5/8" 6 Point Deep Socket
55	3/8" Dr x 11/16" 6 Point Deep Socket
56	3/8" Dr x 3/4" 6 Point Deep Socket
57	3/8" Dr x 13/16" 6 Point Deep Socket
58	3/8" Dr x 8mm 6 Point Socket
59	3/8" Dr x 9mm 6 Point Socket
60	3/8" Dr x 10mm 6 Point Socket
61	3/8" Dr x 11mm 6 Point Socket
62	3/8" Dr x 12mm 6 Point Socket
63	3/8" Dr x 13mm 6 Point Socket
64	3/8" Dr x 14mm 6 Point Socket
65	3/8" Dr x 15mm 6 Point Socket
66	3/8" Dr x 16mm 6 Point Socket
67	3/8" Dr x 17mm 6 Point Socket
68	3/8" Dr x 18mm 6 Point Socket
69	3/8" Dr x 19mm 6 Point Socket
70	3/8" Dr x 8mm 6 Point Deep Socket
71	3/8" Dr x 9mm 6 Point Deep Socket
72	3/8" Dr x 10mm 6 Point Deep Socket
73	3/8" Dr x 11mm 6 Point Deep Socket

Kit Count Product Description

74	3/8" Dr x 12mm 6 Point Deep Socket
75	3/8" Dr x 13mm 6 Point Deep Socket
76	3/8" Dr x 14mm 6 Point Deep Socket
77	3/8" Dr x 15mm 6 Point Deep Socket
78	3/8" Dr x 16mm 6 Point Deep Socket
79	3/8" Dr x 17mm 6 Point Deep Socket
80	3/8" Dr x 18mm 6 Point Deep Socket
81	3/8" Dr x 19mm 6 Point Deep Socket
82	Flex Handle
83	3" Extension
84	6" Extension
85	Universal Joint
86	High Torque Ratchet
87	Blow Mould Case
88	3/8" Female - 1/4" Male Adapter
89	3/8" Female - 1/2" Male Adapter
90	1/4" Raised Panel Combination Wrench
91	5/16" Raised Panel Combination Wrench
92	3/8" Raised Panel Combination Wrench
93	7/16" Raised Panel Combination Wrench
94	1/2" Raised Panel Combination Wrench
95	9/16" Raised Panel Combination Wrench
96	5/8" Raised Panel Combination Wrench
97	11/16" Raised Panel Combination Wrench
98	3/4" Raised Panel Combination Wrench
99	13/16" Raised Panel Combination Wrench
100	7/8" Raised Panel Combination Wrench
101	15/16" Raised Panel Combination Wrench
102	1" Raised Panel Combination Wrench
103	1-1/16" Raised Panel Combination Wrench
104	1-1/8" Raised Panel Combination Wrench
105	1-1/4" Raised Panel Combination Wrench
106	Terylene Pouch
107	7mm Raised Panel Combination Wrench
108	8mm Raised Panel Combination Wrench
109	9mm Raised Panel Combination Wrench
110	10mm Raised Panel Combination Wrench
111	11mm Raised Panel Combination Wrench
112	12mm Raised Panel Combination Wrench
113	13mm Raised Panel Combination Wrench
114	14mm Raised Panel Combination Wrench
115	15mm Raised Panel Combination Wrench
116	16mm Raised Panel Combination Wrench
117	17mm Raised Panel Combination Wrench
118	18mm Raised Panel Combination Wrench
119	19mm Raised Panel Combination Wrench
120	20mm Raised Panel Combination Wrench
121	21mm Raised Panel Combination Wrench
122	22mm Raised Panel Combination Wrench
123	23mm Raised Panel Combination Wrench
124	24mm Raised Panel Combination Wrench
125	26mm Raised Panel Combination Wrench
126	27mm Raised Panel Combination Wrench
127	30mm Raised Panel Combination Wrench
128	32mm Raised Panel Combination Wrench
129	Terylene Pouch
130	10" Professional Adjustable Wrench
131	Phillips: #2 x 1-1/2" Jumbo Handle Screwdriver
132	Phillips: #1 x 3" Jumbo Handle Screwdriver
133	Phillips: #2 x 4" Jumbo Handle Screwdriver
134	Phillips: #3 x 6" Jumbo Handle Screwdriver
135	Square: #2 x 1-1/2" Jumbo Handle Screwdriver
136	Square: #1 x 4" Jumbo Handle Screwdriver
137	Square: #2 x 5" Jumbo Handle Screwdriver
138	Square: #3 x 6" Jumbo Handle Screwdriver
139	Slot Square Shaft: 1/4 x 1-1/2" Jumbo Handle Screwdriver
140	Slot Square Shaft: 1/4 x 4" Jumbo Handle Screwdriver
141	Slot Square Shaft: 5/16 x 6" Jumbo Handle Screwdriver
142	Slot Square Shaft: 3/8 x 10" Jumbo Handle Screwdriver
143	Slot Round Shaft: 3/16 x 3" Jumbo Handle Screwdriver
144	Slot Round Shaft: 3/16 x 6" Jumbo Handle Screwdriver
145	Blow Mould Case
146	T10 x 4" Jumbo Handle Torx Screwdriver

Kit Count Product Description

147	T15 x 4" Jumbo Handle Torx Screwdriver
148	T20 x 4" Jumbo Handle Torx Screwdriver
149	T25 x 4" Jumbo Handle Torx Screwdriver
150	T27 x 4" Jumbo Handle Torx Screwdriver
151	T30 x 4" Jumbo Handle Torx Screwdriver
152	Terylene Pouch
153	8" Slip Joint Pliers
154	8" Lineman's Pliers
155	8" Long Nose Pliers
156	7-1/2" Diagonal Cutters
157	8" Bent Nose Pliers
158	Terylene Pouch
159	6" External Straight Tip for Snap Ring Pliers
160	6" External Bent Tip for Snap Ring Pliers
161	6" Internal Straight Tip for Snap Ring Pliers
162	6" Internal Bent Tip for Snap Ring Pliers
163	Handle for Snap Ring Pliers
164	10" Curved Jaw Locking Pliers
165	9" Multifunction Wire Stripper
166	Quick Adjustable Tubing Cutter
167	16 oz Hickory Handle Ball Pen Hammer
168	1.5mm Short Arm Hex Key
169	2.0mm Short Arm Hex Key
170	2.5mm Short Arm Hex Key
171	3.0mm Short Arm Hex Key
172	4.0mm Short Arm Hex Key
173	4.5mm Short Arm Hex Key
174	5.0mm Short Arm Hex Key
175	5.5mm Short Arm Hex Key
176	6.0mm Short Arm Hex Key
177	7.0mm Short Arm Hex Key
178	8.0mm Short Arm Hex Key
179	9.0mm Short Arm Hex Key
180	10.0mm Short Arm Hex Key
181	1/16" Long Arm Hex Key
182	5/64" Long Arm Hex Key
183	3/32" Long Arm Hex Key
184	7/64" Long Arm Hex Key
185	1/8" Long Arm Hex Key
186	9/64" Long Arm Hex Key
187	5/32" Long Arm Hex Key
188	3/16" Long Arm Hex Key
189	7/32" Long Arm Hex Key
190	1/4" Long Arm Hex Key
191	5/16" Long Arm Hex Key
192	3/8" Long Arm Hex Key
193	Plastic Rack
194	12" Hacksaw Frame
195	1/8" Pin Punch
196	3/16" Pin Punch
197	1/4" Pin Punch
198	3/16" Solid Punch
199	1/2" Cold Chisel
200	5/8" Cold Chisel
201	3/4" Cold Chisel
202	5/32" Centre Punch
203	Terylene Pouch
204	18" Pry Bar
205	26" x 12" 6 Drawer B&G Series Mechanic's Chest
206	1" Short Scraper
207	Battery Post and Terminal Cleaner
208	6-12 Volt Circuit Tester
209	Long Telescoping Magnet
210	Strap Filter Wrench
211	Universal Master Feeler Gauge



842124
Included with kit

Kit Count	Product Description
1	1/16" JET-KUT Black Oxide H.S.S. Jobber Drill Bit
2	5/64" JET-KUT Black Oxide H.S.S. Jobber Drill Bit
3	3/32" JET-KUT Black Oxide H.S.S. Jobber Drill Bit
4	7/64" JET-KUT Black Oxide H.S.S. Jobber Drill Bit
5	1/8" JET-KUT Black Oxide H.S.S. Jobber Drill Bit
6	9/64" JET-KUT Black Oxide H.S.S. Jobber Drill Bit
7	5/32" JET-KUT Black Oxide H.S.S. Jobber Drill Bit
8	11/64" JET-KUT Black Oxide H.S.S. Jobber Drill Bit
9	3/16" JET-KUT Black Oxide H.S.S. Jobber Drill Bit
10	13/64" JET-KUT Black Oxide H.S.S. Jobber Drill Bit
11	7/32" JET-KUT Black Oxide H.S.S. Jobber Drill Bit
12	15/64" JET-KUT Black Oxide H.S.S. Jobber Drill Bit
13	1/4" JET-KUT Black Oxide H.S.S. Jobber Drill Bit
14	17/64" JET-KUT Black Oxide H.S.S. Jobber Drill Bit
15	9/32" JET-KUT Black Oxide H.S.S. Jobber Drill Bit
16	19/64" JET-KUT Black Oxide H.S.S. Jobber Drill Bit
17	5/16" JET-KUT Black Oxide H.S.S. Jobber Drill Bit
18	21/64" JET-KUT Black Oxide H.S.S. Jobber Drill Bit
19	11/32" JET-KUT Black Oxide H.S.S. Jobber Drill Bit
20	23/64" JET-KUT Black Oxide H.S.S. Jobber Drill Bit
21	3/8" JET-KUT Black Oxide H.S.S. Jobber Drill Bit
22	25/64" JET-KUT Black Oxide H.S.S. Jobber Drill Bit
23	13/32" JET-KUT Black Oxide H.S.S. Jobber Drill Bit
24	27/64" JET-KUT Black Oxide H.S.S. Jobber Drill Bit
25	7/16" JET-KUT Black Oxide H.S.S. Jobber Drill Bit
26	29/64" JET-KUT Black Oxide H.S.S. Jobber Drill Bit
27	15/32" JET-KUT Black Oxide H.S.S. Jobber Drill Bit
28	31/64" JET-KUT Black Oxide H.S.S. Jobber Drill Bit
29	1/2" JET-KUT Black Oxide H.S.S. Jobber Drill Bit
30	Metal Box with Drill Index
31	1/4" Dr x 3/16" 6 Point Socket
32	1/4" Dr x 7/32" 6 Point Socket
33	1/4" Dr x 1/4" 6 Point Socket
34	1/4" Dr x 9/32" 6 Point Socket
35	1/4" Dr x 5/16" 6 Point Socket
36	1/4" Dr x 11/32" 6 Point Socket
37	1/4" Dr x 3/8" 6 Point Socket
38	1/4" Dr x 7/16" 6 Point Socket
39	1/4" Dr x 1/2" 6 Point Socket
40	1/4" Dr x 3/16" 6 Point Deep Socket
41	1/4" Dr x 7/32" 6 Point Deep Socket
42	1/4" Dr x 1/4" 6 Point Deep Socket
43	1/4" Dr x 9/32" 6 Point Deep Socket
44	1/4" Dr x 5/16" 6 Point Deep Socket
45	1/4" Dr x 11/32" 6 Point Deep Socket
46	1/4" Dr x 3/8" 6 Point Deep Socket
47	1/4" Dr x 7/16" 6 Point Deep Socket
48	1/4" Dr x 1/2" 6 Point Deep Socket
49	2" Extension
50	6" Extension

Kit Count	Product Description
51	Universal Joint
52	6" Spinner Handle
53	1/4" Oval Head Ratchet
54	Metal Case
55	3/8" Dr x 3/8" 6 Point Socket
56	3/8" Dr x 7/16" 6 Point Socket
57	3/8" Dr x 1/2" 6 Point Socket
58	3/8" Dr x 9/16" 6 Point Socket
59	3/8" Dr x 5/8" 6 Point Socket
60	3/8" Dr x 11/16" 6 Point Socket
61	3/8" Dr x 3/4" 6 Point Socket
62	3/8" Dr x 3/8" 6 Point Deep Socket
63	3/8" Dr x 7/16" 6 Point Deep Socket
64	3/8" Dr x 1/2" 6 Point Deep Socket
65	3/8" Dr x 9/16" 6 Point Deep Socket
66	3/8" Dr x 5/8" 6 Point Deep Socket
67	3/8" Dr x 11/16" 6 Point Deep Socket
68	3/8" Dr x 3/4" 6 Point Deep Socket
69	3/8" Dr x 13/16" 6 Point Deep Socket
70	Flex Handle
71	3" Extension
72	6" Extension
73	Universal Joint
74	3/8" Oval Head Ratchet
75	Blow Mould Case
76	3/8" Dr x 5/8" Spark Plug Socket
77	3/8" Raised Panel Combination Wrench
78	7/16" Raised Panel Combination Wrench
79	1/2" Raised Panel Combination Wrench
80	9/16" Raised Panel Combination Wrench
81	5/8" Raised Panel Combination Wrench
82	11/16" Raised Panel Combination Wrench
83	3/4" Raised Panel Combination Wrench
84	13/16" Raised Panel Combination Wrench
85	7/8" Raised Panel Combination Wrench
86	15/16" Raised Panel Combination Wrench
87	1" Raised Panel Combination Wrench
88	Terylene Pouch
89	10" Professional Adjustable Wrench
90	4" Jumbo Handle Screwdriver
91	6" Jumbo Handle Screwdriver
92	#1 Jumbo Handle Phillips Screwdriver
93	#2 Jumbo Handle Phillips Screwdriver
94	#1 Square Jumbo Handle Screwdriver
95	#2 Square Jumbo Handle Screwdriver
96	Plastic Rack
97	8" Slip Joint Pliers
98	8" Lineman's Pliers
99	8" Long Nose Pliers
100	7-1/2" Diagonal Cutters

Kit Count	Product Description
101	8" Bent Nose Pliers
102	Terylene Pouch
103	9-1/2" Groove Joint Pliers
104	10" Curved Jaw Locking Pliers
105	16 Oz Fibreglass Claw Hammer
106	0.05" Short Arm Hex Key
107	1/16" Short Arm Hex Key
108	5/64" Short Arm Hex Key
109	3/32" Short Arm Hex Key
110	7/64" Short Arm Hex Key
111	1/8" Short Arm Hex Key
112	9/64" Short Arm Hex Key
113	5/32" Short Arm Hex Key
114	3/16" Short Arm Hex Key
115	7/32" Short Arm Hex Key
116	1/4" Short Arm Hex Key
117	5/16" Short Arm Hex Key
118	3/8" Short Arm Hex Key
119	Plastic Rack
120	1/8" Pin Punch
121	3/16" Pin Punch
122	1/4" Pin Punch
123	3/16" Solid Punch
124	1/2" Cold Chisel
125	5/8" Cold Chisel
126	3/4" Cold Chisel
127	5/32" Centre Punch
128	Terylene Pouch
129	16ft Tape Measure
130	Telescopic Pick Up Tool
131	21" 3 Drawer Steel Hand Tool Box



REPLACEMENT PARTS

For the most part, JET Hand Tools carry a lifetime warranty. However, the following JET hand tools have wear parts that are not covered under warranty. The moving parts found on these products can wear out through normal use and can easily be replaced by purchasing and installing the repair kits indicated below.



672902



674909

Flex Bar

- The swivel drive ends on these units are designed to fail before the chrome drive holder breaks under extreme use
- The drive end is easily replaced by removing the drive end screw and broken drive end and installing the replacement drive end and screw

PROD. NO.	MOD. NO.	Drive	Repair Kit
672902	SA1201	1/2"	900218
672903	SA1202	1/2"	900218
672918	SA1213	1/2"	900219
673909	SA7508	3/4"	900230
674909	SA1008	1"	900246

RATCHETS

- Like all makes of ratchets, JET ratcheting mechanisms will wear with extensive use or break when extreme pressure or abuse is applied
- JET ratchet repair kits are available for all ratchet models and are available for purchase and easily installed by your JET hand tool distributor



670901



670926A



672927B

RH - Standard Duty

PROD. NO.	MOD. NO.	Drive	Repair Kit
670901	RH-25	1/4"	900202
671901	RH-38	3/8"	900203
672901	RH-50	1/2"	900204
673901	RH-75	3/4"	900205
674901	RH-100	1"	900210

RHQ Series - Heavy Duty

PROD. NO.	MOD. NO.	Drive	Repair Kit
670926A	RHQ-14	1/4"	900235
670928	RHQ-14L	1/4"	900235
670929	RHQ-14F	1/4" (Flex)	900235
671926A	RHQ-38	3/8"	900236
671942A	RHQ-38FS	3/8"	900236
671943	RHQ-38F2	3/8" (Flex)	900253
671943A	RHQ-38F2	3/8"	900236
671945	RHQ-38L	3/8"	900236
672926B	RHQ-12	1/2"	900239
672927B	RHQ-12L	1/2"	900239
672929	RHQ-12F	1/2" (Flex)	900259
673922	RHQ-34	3/4"	900215

RHD Series - Super Heavy Duty

PROD. NO.	MOD. NO.	Drive	Repair Kit
673923	RHD-3400	3/4"	900240
674906	RHD-1036	1"	900241

RA Series - Ratchet Adapters

PROD. NO.	MOD. NO.	Drive	Repair Kit
670921	RA1452	1/4"	900266
671921	RA3852	3/8"	900267
672921	RA1252	1/2"	900268

SH Series

PROD. NO.	MOD. NO.	Drive	Repair Kit
670922	SH270-14	1/4"	900261
671922	SH270-38	3/8"	900262
672922	SH270-12	1/2"	900263

HT72 - 72 Tooth Twin Pawl Series

PROD. NO.	MOD. NO.	Drive	Repair Kit
670927	HT-1472	1/4"	900225
671928	HT-3872	3/8"	900226
672928	HT-1272	1/2"	900227
673924	HT-3472	3/4"	900228

MHR Series - 60 Tooth Mini Head

PROD. NO.	MOD. NO.	Drive	Repair Kit
671941	MHR-3860	3/8"	900252

SR3872 - 72 Tooth Stubby

PROD. NO.	MOD. NO.	Drive	Repair Kit
671940	SR3872	3/8"	900251
671940B	SR3872	3/8"	900251

HSR 3800 - Rotating Head Ratchet

PROD. NO.	MOD. NO.	Drive	Repair Kit	Handle Repair Kit
671944	HSR-3800	3/8"	900257	900258



674906

673923



670921



670927



671941



718906

TORQUE WRENCHES

Torque Wrenches

PROD. NO.	MOD. NO.	Drive	Repair Kit
718902	JTW-1425	1/4"	PDN-JTW1425-RK
718903	JMTW-1425	1/4"	PDN-JMTW1425RK
718906	JMTW-3800	3/8"	PUT-JMTW3800
718906	JMTW-3800A	3/8"	PUT-JMTW3800A
718908	JTW-3880	3/8"	PDN-JTW3880-RK
718909	JMTW-3875	3/8"	PDN-JMTW3875-RK
718909	JMTW-3875HD	3/8"	PDN-JMTW3875A-RK
718861 - 865	Tire torque wrenches	1/2"	PDN-JTTW-RK
718911	JTW-12150	1/2"	PDN-JTW12150-RK
718912	JTW-12250	1/2"	PDN-JTW12250-RK
718913	JMTW-12150	1/2"	PDN-JMTW12250-RK
718913	JMTW-12150HD	1/2"	PDN-JMTW12250A-RK
718914	JMTW-12250 (black handle)	1/2"	PDN-JMTW12250-RK
718914	JMTW-12250 (red handle)	1/2"	PDN-JTW12250-RK
718914	JMTW-12250HD (go through plug)	1/2"	PDN-JMTW12250A-RK
718933	JPTW-38100	3/8"	PDN-JPTW38100-RK
718935	JPTW-12150	1/2"	PDN-JPTW12150-RK
718936	JPTW-12250	1/2"	PDN-JPTW12250-RK
719069	JMTW-5250	1/2"	PUT-JMTW5250
719069	JMTW-5250A	1/2"	PUT-JMTW5250A
718916	JMTW-7500	3/4"	PUT-JMTW7500
718917	JTW-34300	3/4"	PDN-JTW34600-RK
718918	JTW-34600	3/4"	PDN-JTW34600-RK
718922	JTW-10700	1"	PDN-JTW10700-RK

PIPE WRENCHES

Pipe Wrenches - HD and AL Series

Jaw Size	Hook Jaw	Knurls	Heel Jaw	Springs
8"	PMZ-1020802	PMZ-1020804	PMZ-1020815	PMZ-1020813
10"	PMZ-1021002	PMZ-1021004	PMZ-1021015	PMZ-1021013
12"	PMZ-1021202	PMZ-1021204	PMZ-1021215	PMZ-1021213
14"	PMZ-1021402	PMZ-1021404	PMZ-1021415	PMZ-1021413
18"	PMZ-1021802	PMZ-1021804	PMZ-1021815	PMZ-1021813
24"	PMZ-1022402	PMZ-1022404	PMZ-1022415	PMZ-1022413
36"	PMZ-1023602	PMZ-1023604	PMZ-1023615	PMZ-1023613
48"	PMZ-1044802	PMZ-1044804	PMZ-1044815	PMZ-1044813

Pipe Wrenches - PW and PWA Series

Jaw Size	Hook Jaw	Knurls	Heel Jaw	Springs
8"	PDN-PW8HJ	PDN-PW8NT	PDN-PW8HJP	PDN-PW8SF
10"	PDN-PW10HJ	PDN-PW10NT	PDN-PW10HJP	PDN-PW10SF
12"	PDN-PW12HJ	PDN-PW12NT	PDN-PW12HJP	PDN-PW12SF
14"	PDN-PW14HJ	PDN-PW14NT	PDN-PW14HJP	PDN-PW14SF
18"	PDN-PW18HJ	PDN-PW18NT	PDN-PW18HJP	PDN-PW18SF
24"	PDN-PW24HJ	PDN-PW24NT	PDN-PW24HJP	PDN-PW24SF
36"	PDN-PW36HJ	PDN-PW36NT	PDN-PW36HJP	PDN-PW36SF
48"	PDN-PW48HJ	PDN-PW48NT	PDN-PW48HJP	PDN-PW48SF



710230

CUSHION GRIP MULTI-BIT DRIVERS

Replacement Bits



For 720531 (JKMD-5S) / 720534 (JKMD-10)

PROD. NO.	Size
720580	3/16" SLOT x #1 PHILLIPS
720581	3/16" SLOT x #2 SQUARE
720582	1/4" SLOT x #2 PHILLIPS
720583	#1 SQUARE x #2 SQUARE
720584	#3 PHILLIPS x #3 PHILLIPS

For 720533 (JKMD-6 / 720590 (JRSD-19)

PROD. NO.	Size
720592	1/8" SLOT x #0 PHILLIPS
720593	3/16" SLOT x #1 PHILLIPS
720594	1/4" SLOT x #2 PHILLIPS
720595	#1 SQUARE x #2 SQUARE
720596	T10 x T15 TORX*
720597	T20 x T25 TORX*
720598	1/8" HEX x 3/16" HEX
720599	5/16" SLOT x #3 PHILLIPS



MULTI-BIT DRIVERS

Replacement Bits

Replacement Bits

Replacement Bit For H3400 (P0 - P3)	H3400C
Replacement Bit For H3400 (P1 - P2)	H3400D
Replacement Bit For H3400 (S1 - S2)	H3400E
Replacement Bit For H3400 (T10 - T15)	H3400F
Replacement Bit For H3400 (T20 - T25)	H3400G
Replacement Bit For H3400 (T27 - T30)	H3400H
Replacement Bit For H3400 (F4 - F6)	H3400J
Replacement Bit For H3400 (S0 - S3)	H3400K



WARRANTY

WARRANTY POLICY

JET EQUIPMENT & TOOLS LTD. (JET), makes every effort to ensure its products are manufactured to the highest standards and each is warranted against defects in materials and workmanship for the useful life of the product when used for the purpose for which it was designed.

This warranty applies only to JET products purchased new from a JET authorized distributor. JET product warranties are extended to the original retail purchaser only.

This warranty does not apply to any product showing signs of abuse, misuse, alteration, or having been improperly maintained or repaired.

This warranty does not cover damage attributable to normal wear and tear.

Any JET product that fails during normal use and is within the specified warranty period for that product will be repaired or replaced at JET's discretion. Repairs and/or replacements are warranted as described for the specific product and only for the remainder of the original warranty period.

Repair or replacement is the exclusive remedy for defective product under this warranty. Warranty is expressly in lieu of all other warranties, including the implied warranty of merchantability or any implied warranty of fitness for a particular application.

Any JET product for which there is a warranty claim should be returned PREPAID to an authorized JET distributor or service center. Authorized Warranty Depots are found at www.surewerx.com

ALL warranty claims must be accompanied by proof of purchase and an explanation of the defect or failure. It is the customer's responsibility to provide this information.

JET shall not be held liable for any consequential or incidental damages for breach of any expressed or implied warranty on their products.

No claims for damages of any type will be considered and all products are sold with this understanding.

Any costs incurred to obtain warranty consideration or services are the Customer's responsibility including shipping and handling, travel, lost time, or lost production.

EXCEPT AS LISTED BELOW, ALL JET HAND TOOL PRODUCTS ARE COVERED BY OUR LIMITED LIFETIME WARRANTY

NOTE: Specifically excluded from this guarantee are reducing adaptors, thin wall power sockets, mag wheel power sockets, power bits and insert bits and accessories, hacksaw blades, scratch brushes, damaged insulating materials, kneeling pads, consumable components

INDESTRUCTIBLE HANDLE HAMMERS - LIMITED LIFETIME WARRANTY

Warranty extends to fracturing or permanent deformation of the handle only, and only when used for its intended purpose. Heads are warranted not to suffer a complete

separation; however in time it is possible the locking plate will begin to bend, indicating the tool has reached its useful life and may indicate the need for a heavier hammer. Chips, cracks, and cuts to the rubber overmould are excluded from this warranty.

TWO YEAR WARRANTY

Machinery
Torque Wrenches

NOTE: Dropping or striking against hard objects, using for removal of fasteners, or failure to return wrench to lowest setting can all contribute to loss of accuracy and is not the fault of the tool.

ONE YEAR WARRANTY

Hose Reels (hose is discretionary based on examination)
Lubricating Equipment (seals and hoses excluded)
Torque Multipliers
Precision Measuring Tools
Electronic Measuring Tools Thermometers
Tire Gauges Compression/Pressure Gauges
Automotive Gauges
Timing Lights
Pry Bars and Wrecking Bars
Gear Pullers, Bearing Separators
Crawlers/Seats

CALIBRATION IS NOT COVERED BY WARRANTY EXCEPT WHEN REQUIRED DUE TO WARRANTY REPAIR SERVICE

NOTE: Batteries supplied with certain products may have been exposed to a long shelf life resulting in low energy or dead batteries. Please source replacement batteries locally. Dead batteries do not constitute a warranty claim.

REPAIRABLE WEAR PARTS

Flex Bar Swivels, Ratchet Repair Kits, Torque Wrench Repair Kits, Pipe Wrench Jaws, Springs and Knurls, Bolt Cutter heads, Bench Vise (excluding casting).

TOOL BOXES

Tool boxes are warranted against defects in materials and workmanship when used for the purpose for which they were designed for the periods specified below. Moving heavily loaded tool boxes is the most common cause of damage. If the tool box must be moved regularly choose one of a sufficient duty rating.

Super Pro, SHD, Treasure Series - Limited Lifetime
Pro Series and B&G Series - 5 years

SUMO Series, jobsite, truck box, and hand held tool boxes- 2 years

Rolling tool carts - 1 year

NOTE: Evidence of drawer overload, shock, impact, use as a mobile tool box (unless specifically designed for this purpose) or lack of maintenance voids warranty.

SAFETY
AND
PRODUCTIVITY

DESIGN

With the most advanced manufacturing technologies and the highest quality materials, JET abrasives are built for peak performance

QUALITY

From ceramic grain flap discs, triple reinforced wheels to cobalt drill bits, JET abrasives exceed industry standards

STANDARDS

Our products meet or exceed industry standards to ensure you get the job done safely and efficiently

ABRASIVES

DID YOU KNOW?

Our products are clearly labelled and colour coded to ensure you use the right product for the right application



WHEEL GUIDE



- Material Used On**
- Steel ●
 - Stainless Steel ●
 - Concrete ●
 - Asphalt ●
 - Aluminum ●

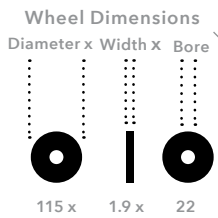

Wheel Grade / Grit
(Grain type, Grain Size and Bond Hardness)

Wheel Shape
(Type 1, Type 27)

Application

Tool Used On

Product Number

Maximum Operating Speed

Filler / Free Contaminant

Safety Standards

Wheel Shapes

Type 1 (F41)
Straight cut-off wheels

Type 1
Straight grinding wheels

Type 27 (F42)
Depressed cut-off wheels

Type 27 (F27)
Depressed grinding wheels

Type 11
Cup wheels

Type 16, 18, 18R
Plugstones

Safety Symbols

- Wear **Ear and Eye** Protection
- Wear **Ear** Protection
- Wear **Eye** Protection
- Wear **Hand** Protection
- Wear **Dust** Protection
- Refer to safety information on website (**MSDS, WHMIS, etc.**)

Wheel Specifications

A24R

A **24** **R**

Grain
Grain Sizes
Bond Hardness

Grain
Aluminum Oxide (AlO) A
Silicon Carbide (SiC) C
Zirconia Alumina (ZA) ZA
Ceramic Grain (CG) CG

Grain Sizes
Coarse 8, 10, 12, 14, 16, 20, 24
Medium 30, 36, 46, 54, 60
Fine 80, 100, 12, 15, 180
Very Fine 220, 240, 280, 320, 400, 600

Bond Hardness
Soft B, D, E, F, G, H
Medium I, J, K, L, M, N, O, P
Hard Q, R, S, T, U, V, X, Y, Z

TABLE OF CONTENTS

Wheel Guide.....	346	Selection Chart	349
Performance Level Guide	348	Icon Legend	349

Cutting

350

Cut-Off Wheels (for Die Grinders).....	352-353	Cut-Off Wheels (for Stationary Cut-Off Machines).....	364
Type 1 Wheel Adapters	353	Diamond Blades (for Angle Grinders, Circular Saws, Tub Saws).....	365-367
Cut-Off Wheels (for Angle Grinders)....	354-358	Diamond Blades (for Tile Saws and Angle Grinders).....	368
Cut-Off Wheels (for Circular Saws).....	359	Diamond Blades (for Portable Gas and Electric Saws)	369-370
Cut-Off Wheels (for High Speed Gas Saws).....	360-361		
Cut-Off Wheels - (for Portable Chop Saws).....	362-363		

Cutting & Grinding

371

Depressed Centre Wheels (for Angle Grinders).....	372 -373
------------------------------------------------------	----------

Grinding

374

Depressed Centre Wheels (for Die Grinders)	373-376	Mounted Points (for Die Grinders).....	381
Depressed Centre Wheels (for Angle Grinders).....	377-378	Cup Wheels (for Angle Grinders).....	381
Bench Grinding Wheels.....	379-380	Plug Stones (for End Grinders).....	382
Bushings.....	380	Resin Bond Straight Wheels (for End Grinders).....	382
		Diamond Cup Wheels (for Angle Grinders).....	383

Blending and Sanding

384

Flap Discs (for Angle Grinders).....	386	Shop Rolls	394-395
Trimable Flap Discs (for Angle Grinders)....	387	Resin Fibre Sanding Discs (for Angle Grinders).....	396-397
Flap Discs (for Angle Grinders).....	388	Semi Flexible Discs - (for Angle Grinders).....	397
Curved Edge Flap Disc (for Angle Grinders) ..	389	Adjustable Pin Wrench	398
Roll-On Flap Discs (for Die Grinders).....	390	Turbo Style Back-Up Pads	398
Cloth sanding Discs (for Die Grinders).....	391	Flange Nuts for Turbo Style Back-Up Pads....	398
Back-Up Pads (for Die Grinders).....	392		
Flap Wheels - Mandrel Mounted (for Die Grinders)	393		

Surface Conditioning

399

Flap Disc Surface Conditioning (for Angle Grinders).....	400	1/4" Mandrel (For 1/2" Arbor Hole Straight Wheels).....	403
Abrasive Hand Pads.....	401	Surface Conditioning Discs (for Die Grinders)	403
Stripping Discs (for Bench Grinders & Drills).....	402	Surface Conditioning Discs Scrim Back Discs (for Angle Grinders).....	404
Stripping Discs (for Angle Grinders)	402	Gripper Back-up Pads (for Angle Grinders).....	404
Stripping Discs (for Die Grinders).....	402		
Roll-On Surface Conditioning Discs (for Die Grinders)	403		

Brushing

405

Crimped Wire Wheel Brushes (for Bench Grinders).....	406	Knot Twisted Conical (Bevel) Brushes (for Angle Grinders).....	412
Adapter Plates	407	Stringer Bead Brushes (for Angle Grinders)....	413
Hand Scratch Brushes	407	Full Cable Twist Knot Wheels (for Angle Grinders).....	414
Maxi-Crimp Cup Brushes - (for Angle Grinders).....	408	Crimped Wire Wheel Brushes (for Angle Grinders).....	415
Crimped Cup Brushes (for Angle Grinders)....	409	Full Cable Twist Knot Wheels (for Die Grinders, End Grinders and Bench Grinders).....	416
Knot Twisted Cup Brushes High Performance (for Angle Grinders).....	410	Knot Twisted End Brushes (for Drills and Die Grinders).....	416
Knot Banded Cup Brushes (for Angle Grinders).....	411	Crimped End Brushes (for Drills and Die Grinders).....	417
Crimped Conical (Bevel) Brushes High Performance (for Angle Grinders).....	412		

Tooling

418

Carbide Burs (for Die Grinders).....	421 - 424	Taps & Dies	436-445
Drill Bits (for Drills and Drill Presses).....	425-434	Holesaws	446-448
Car Reamers (for Drills and Drill Presses).....	435	Files	449-457
Step Drills (for Drills and Drill Presses).....	435	Hacksaw Blades	458
		Safety Guide	459

PERFORMANCE LEVEL GUIDE

POWER **X**TREME[®]

The new super-high performance brand from JET that replaces POWERPLUS TZ+ and POWERPLUS XP+



Brand	Purpose	Performance Level	Label Colour
POWER ABRASIVE[®]	General Purpose	* GOOD	White
POWERPLUS[®]	High Performance	** BETTER	Silver
POWER XTREME[®]	Super-High Performance	*** BEST	Black

SELECTION CHART

	Steel	Stainless	Aluminum	Concrete	POWER ABRASIVE	POWERPLUS	POWER-XTREME	SUPER CHOP
CUTTING								
Die Grinder	X				X	X		
Angle Grinder	X	X	X	X	X	X	X	
Circular Saw	X	X		X	X		X	
Gas Saw	X			X	X	X		
Chop Saw	X	X	X		X			X
Stationary Saw	X	X			X	X	X	
CUTTING & GRINDING								
Angle Grinder	X	X				X	X	
GRINDING								
Die Grinder	X				X			
Angle Grinder	X	X	X	X	X	X	X	

ICON LEGEND

For Steel		For Masonry	
For Stainless Steel		Iron, Sulphur and Chlorine Free	
For Aluminum		Includes Case	
For Concrete		Includes Pouch	
For Asphalt		Warning Note	
For Brick		New	
For Wood		JET Exclusive	





CUTTING





CUT-OFF WHEELS (FOR DIE GRINDERS/CUT-OFF TOOLS)

POWER ABRASIVE™



GOOD**

501012

POWER ABRASIVE

Cut-Off Wheels - General Purpose (for Die Grinders)

- Ideal for general purpose cutting of steel materials in a wide variety of automotive and industrial applications
- These small diameter cut-off wheels are used on all electric and air die grinders as well as 3" and 4" air cut-off tools
- Designed to offer good cutting performance at an economical cost



TYPE 1

PROD. NO.	Size (inches)	Grade	Max. RPM	Pkg. Qty.
501002	2 x 1/16 x 3/8	A46T	38,200	50
501004	2 x 1/8 x 3/8	A46T	38,200	50
501011	3 x 1/32 x 3/8	A60T	25,460	25
501012	3 x 1/16 x 3/8	A46T	25,460	25
501014	3 x 1/8 x 3/8	A46T	25,460	25
501017	4 x 1/16 x 3/8	A46T	19,100	25
501022	4 x 1/16 x 5/8	A46T	19,100	25

5 PACKS

501043	3 x 1/32 x 3/8	A60T	25,460	5 x 501011
501044	3 x 1/16 x 3/8	A46T	25,460	5 x 501012

- POWERPLUS® high performance cut-off wheels are excellent for cutting all steel materials while offering outstanding cutting speed and long wheel life
- Used on all electric and air die grinders as well as 3" and 4" air cut-off tools



TYPE 1

PROD. NO.	Size (inches)	Grade	Max. RPM	Pkg. Qty.
501052	2 x 1/16 x 3/8	A60	38,200	100
501054	2 x 1/8 x 3/8	A36	38,460	100
501057	2-1/2 x 1/16 x 3/8	A60	30,000	100
501061	3 x 1/32 x 3/8	A60	25,460	100
501062	3 x 1/16 x 3/8	A60	25,460	100
501063	3 x 3/32 x 3/8	A60	25,460	50
501064	3 x 1/8 x 3/8	A36	25,460	50
501065	4 x 1/32 x 3/8	A60	20,140	100
501066	4 x 1/32 x 5/8	A60	20,140	100
501067	4 x 1/16 x 3/8	A60	19,100	100
501072	4 x 1/16 x 5/8	A60	19,100	100

POWERPLUS®



501062



TYPE 1 WHEEL ADAPTERS

With Shank Screw Lock System

- For securing small cut-off wheels to die grinders and cut-off tools
- Easy to use slotted screw locking system for fast wheel change
- Designed to allow ease of access in hard-to-reach areas
- Rust proof black oxide finish

PROD. NO.	Fits Arbor Hole (inches)	Wheel Width Up To (inches)	Shank (inches)
599021	3/8	0 - 3/16	1/4
599024	3/8	1/4 - 1/2	1/4



599021





POWER ABRASIVE™



*** GOOD**

501805



*** GOOD**

501815



*** GOOD**

500719

POWER ABRASIVE

Cut-Off Wheels - General Purpose (for Angle Grinders)

- Significant performance gains make these wheels far superior to other economy wheels in the market
- The economical price, coupled with exceptional cutting performance make these wheels ideal for general purpose cutting in a wide variety of automotive and industrial applications
- **501805** and **501808** wheels are Fe+S+Cl free for contamination free cutting in stainless steel



Prod. No.	Size (inches)	Thickness (mm)	Thickness (inches)	Grade	Max. RPM	Pkg. Qty.
501805	4-1/2 x 3/64 x 7/8	1.2	.045	A60GP	13,300	25
501808	5 x 3/64 x 7/8	1.2	.045	A60GP	12,200	25

PROD. NO.		Pkg. Qty.
501805A02	Same as 501805 in a clamshell package	2
501808A02	Same as 501808 in a clamshell package	2



PROD. NO.	Size (inches)	Thickness (mm)	Thickness (inches)	Grade	Max. RPM	Pkg. Qty.
501811	6 x 3/64 x 7/8	1.2	.045	A46GP	10,200	25
501815	7 x 1/16 x 7/8	1.6	.062	A46GP	8,500	25



PROD. NO.	Size (inches)	Thickness (mm)	Thickness (inches)	Grade	Max. RPM	Pkg. Qty.
500711	4 x 1/8 x 5/8	3.2	.125	A24R	15,300	25
500715	4-1/2 x 1/8 x 7/8	3.2	.125	A24R	13,300	25
500719	5 x 1/8 x 5/8	3.2	.125	A24R	12,300	25
500725	7 x 1/8 x 7/8	3.2	.125	A24R	8,500	25

Cut-Off Wheels - High Performance (for Angle Grinders)

- These wheels are designed for high performance cutting of steel and stainless steel materials
- Fe+S+Cl free wheels are specially formulated for cutting steel and contamination/burn free cutting of all stainless steels
- Fast, and cool cutting; these wheels allow the operator to work with minimal pressure for best control
- Type 27 wheels allow more clearance for flush cutting applications



PROD. NO.	Size (inches)	Thickness (mm)	Thickness (inches)	Grade	Max. RPM	Pkg. Qty.
501521	4-1/2 x 3/64 x 7/8	1.2	.045	ZX60HP	13,300	25
501523	4-1/2 x 3/32 x 7/8	2.5	.095	ZX30HP	13,300	25
501526	5 x 3/64 x 7/8	1.2	.045	ZX60HP	12,200	25
501528	5 x 3/32 x 7/8	2.5	.095	ZX30HP	12,200	25
501531	6 x 3/64 x 7/8	1.2	.045	ZX60HP	10,200	25
501533	6 x 3/32 x 7/8	2.5	.095	ZX30HP	10,200	25
501537	7 x 1/16 x 7/8	1.6	.062	ZX46HP	8,500	25
501538	7 x 3/32 x 7/8	2.5	.095	ZX30HP	8,500	25

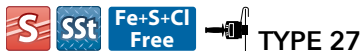

PROD. NO.	Size (inches)	Thickness (mm)	Thickness (inches)	Grade	Max. RPM	Pkg. Qty.
501621	4-1/2 x 3/64 x 7/8	1.2	.045	A60T	13,300	25
501626	5 x 3/64 x 7/8	1.2	.045	A60T	12,200	25
501631	6 x 3/64 x 7/8	1.2	.045	A60T	10,200	25



PROD. NO.	Size (inches)	Thickness (mm)	Thickness (inches)	Grade	Max. RPM	Pkg. Qty.
501622	4-1/2 x 1/16 x 7/8	1.6	.062	A46T	13,300	25
500412	4-1/2 x 3/32 x 7/8	2.5	.094	A36T	13,300	25
501627	5 x 1/16 x 7/8	1.6	.062	A46T	12,200	25
500422	5 x 3/32 x 7/8	2.5	.094	A36T	12,200	25
501632	6 x 1/16 x 7/8	1.6	.062	A46T	10,200	25
501636	7 x 1/16 x 7/8	1.6	.062	A46T	8,600	25

POWERPLUS®



501526



501626



501627





POWER X TREME™



***** BEST**

501576



***** BEST**

501675

POWER-XTREME® (PREVIOUSLY POWERPLUS® TZ+)
Cut-Off Wheels - Super High Performance (for Angle Grinders)

- Manufactured with the most advanced technology of grains, bonds and reinforcements offer fast, cool, burn free cutting of steel and stainless steel
- Specially designed technology ensures the longest life and best performance in its class
- The Type 27 wheels are the preferred wheels for flush cutting applications



PROD. NO.	Size (inches)	Thickness (mm)	Thickness (inches)	Grade	Max. RPM	Pkg. Qty.
501570	4-1/2 x 1/32 x 7/8	1.0	.035	A60PX	13,300	25
501571	4-1/2 x 3/64 x 7/8	1.2	.045	A60PX	13,300	25
501572	4-1/2 x 1/16 x 7/8	1.6	.062	A46PX	13,300	25
501575	5 x 1/32 x 7/8	1.0	.035	A60PX	12,200	25
501576	5 x 3/64 x 7/8	1.2	.045	A60PX	12,200	25
501577	5 x 1/16 x 7/8	1.6	.062	A46PX	12,200	25
501581	6 x 3/64 x 7/8	1.2	.045	A60PX	10,200	25
501582	6 x 1/16 x 7/8	1.6	.062	A46PX	10,200	25
501586	7 x 1/16 x 7/8	1.6	.062	A46PX	8,600	25

PROD. NO.		Pkg. Qty.
501571A02	Same as 501571 in a clamshell package	2
501576A02	Same as 501576 in a clamshell package	2



PROD. NO.	Size (inches)	Thickness (mm)	Thickness (inches)	Grade	Max. RPM	Pkg. Qty.
501670	4-1/2 x 1/32 x 7/8	1.0	.035	A60PX	13,300	25
501671	4-1/2 x 3/64 x 7/8	1.2	.045	A60PX	13,300	25
501672	4-1/2 x 1/16 x 7/8	1.6	.062	A46PX	13,300	25
501675	5 x 1/32 x 7/8	1.0	.035	A60PX	12,200	25
501676	5 x 3/64 x 7/8	1.2	.045	A60PX	12,200	25
501677	5 x 1/16 x 7/8	1.6	.062	A46PX	12,200	25
501681	6 x 3/64 x 7/8	1.2	.045	A60PX	10,200	25
501682	6 x 1/16 x 7/8	1.6	.062	A46PX	10,200	25
501686	7 x 1/16 x 7/8	1.6	.062	A46PX	8,600	25

POWER-XTREME® SST (PREVIOUSLY POWERPLUS® XP+)

Cut-Off Wheels - Super High Performance (for Angle Grinders)

- These wheels offer the longest life and best performance when cutting stainless steel and other hardened materials
- Made from highly refined ingredients; these wheels will not contaminate stainless steel
- POWER-XTREME® SST are the best solution where certified contamination free wheels are required
- Type 27 wheels allow more clearance for flush cutting applications



PROD. NO.	Size (inches)	Thickness (mm)	Thickness (inches)	Grade	Max. RPM	Pkg. Qty.
501722	4-1/2 x 3/64 x 7/8	1.2	.045	A60PX-SST	13,300	25
501727	5 x 3/64 x 7/8	1.2	.045	A60PX-SST	12,200	25
501732	6 x 3/64 x 7/8	1.2	.045	A60PX-SST	10,200	25
501737	7 x 1/16 x 7/8	1.6	.062	A46PX-SST	8,600	25



PROD. NO.	Size (inches)	Thickness (mm)	Thickness (inches)	Grade	Max. RPM	Pkg. Qty.
500322	4-1/2 x 3/64 x 7/8	1.2	.045	A60PX-SST	13,300	25
500327	5 x 3/64 x 7/8	1.2	.045	A60PX-SST	12,200	25
500332	6 x 3/64 x 7/8	1.2	.045	A60PX-SST	10,200	25
500337	7 x 1/16 x 7/8	1.6	.062	A46PX-SST	8,600	25

POWER-XTREME® NF (Previously POWERPLUS® NF)

Cut-Off Wheels - Super High Performance (for Angle Grinders)

- POWER-XTREME® NF cut-off wheels are specially formulated to cut a wide variety of aluminum and other non-ferrous materials without material loading on the wheel
- Manufactured in Europe; these wheels offer extra fast cutting and long wheel life
- Type 27 wheels allow more clearance for flush cutting applications



PROD. NO.	Size (inches)	Thickness (mm)	Thickness (inches)	Grade	Max. RPM	Pkg. Qty.
501705	4-1/2 x 3/64 x 7/8	1.2	.045	A60PX-NF	13,300	25
501708	5 x 3/64 x 7/8	1.2	.045	A60PX-NF	12,200	25
501711	6 x 3/64 x 7/8	1.2	.045	A60PX-NF	10,200	25
501715	7 x 1/16 x 7/8	1.6	.062	A30PX-NF	8,600	25



POWER XTREME™



501727

BEST

POWER XTREME™



501708

BEST



POWERPLUS® CON



BETTER**

500525

POWERPLUS® NF



BETTER**

500575

POWERPLUS® CON

Cut-Off Wheels - High Performance (for Angle Grinders)

- Specially formulated for cutting concrete, stone and masonry
- Made with extremely sharp silicon carbide grains, for fast cutting and long wheel life
- Type 27 wheels allow more clearance for flush cutting applications

Con **TYPE 27**

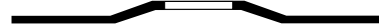

PROD. NO.	Size (inches)	Thickness (mm)	Thickness (inches)	Grade	Max. RPM	Pkg. Qty.
500511	4-1/2 x 1/8 x 7/8	3.2	.125	C30	13,300	25
500525	5 x 1/8 x 7/8	3.2	.125	C30	12,200	25
500535	7 x 1/8 x 7/8	3.2	.125	C30	8,600	25

POWERPLUS® NF

Cut-Off Wheels - High Performance (for Angle Grinders)

- Designed to cut a wide variety of aluminum and other non-ferrous materials without clogging
- Manufactured in Europe, these wheels offer extra fast cutting and long wheel life
- Type 27 wheels allow more clearance for flush cutting applications

Al **TYPE 27**



PROD. NO.	Size (inches)	Thickness (mm)	Thickness (inches)	Grade	Max. RPM	Pkg. Qty.
500561	4-1/2 x 1/8 x 7/8	3.2	.125	AL30	13,300	25
500575	5 x 1/8 x 7/8	3.2	.125	AL30	12,200	25



POWER ABRASIVE

Cut-Off Wheels - General Purpose (for Circular Saws)

- Designed for general purpose cutting of steel (501217), concrete, stone and masonry (501209) materials
- Good cutting performance at an economical cost



PROD. NO.	Size (inches)	Thickness (mm)	Thickness (inches)	Grade	Max. RPM	Pkg. Qty.
501207	7 x 3/32 x 5/8 \diamond 7/8	2.5	.094	A30	8,600	5 / 25
501217	10 x 3/32 x 5/8	2.5	.094	A30	6,110	5 / 25



501209	7 x 3/32 x 5/8 \diamond 7/8	2.5	.094	C30	8,600	5 / 25
--------	-------------------------------	-----	------	-----	-------	--------

POWER-XTREME® (Previously TZ+)

Cut-Off Wheels - Super High Performance (for Circular Saws)

- Manufactured with the most advanced technology of grains, bonds and reinforcements offering fast, cool, burn free cutting of steel and stainless steel
- Specially designed technology ensures the longest life and best performance in its class
- These wheels are designed to minimize the load on the tool and maintain high RPM for a clean cut and best all-around performance



PROD. NO.	Size (inches)	Thickness (mm)	Thickness (inches)	Grade	Max. RPM	Pkg. Qty.
501082	7 x 1/16 x 5/8	1.6	.062	A46PX	8,600	25
501087	8 x 1/16 x 5/8	1.6	.062	A46PX	7,600	25



POWER ABRASIVE™



501217



501209



POWER X TREME™



501087





POWER ABRASIVE™



*** GOOD**

501228



*** GOOD**

501229



*** GOOD**

501328

POWER ABRASIVE

Cut-Off Wheels - General Purpose (for High Speed Gas Saws)

- Designed specifically for use in high speed gas saws
- 12" wheels are double reinforced to withstand the stresses created during free hand cutting operations
- 14" and 16" wheels are triple reinforced for extra strength and stability
- Not recommended for use on portable chop saws



TYPE 1

PROD. NO.	Size (inches)	Thickness (mm)	Thickness (inches)	Grade	Max. RPM	Pkg. Qty.
501220	12 x 1/8 x 20mm	3.2	.125	A24R	6,370	5 / 25
501222	12 x 1/8 x 7/8	3.2	.125	A24R	6,370	5 / 25
501224	12 x 1/8 x 1	3.2	.125	A24R	6,370	5 / 25
501226	14 x 1/8 x 1	3.2	.125	A24R	5,400	5 / 25
501228	14 x 1/8 x 20mm	3.2	.125	A24R	5,400	5 / 25



TYPE 1

PROD. NO.	Size (inches)	Thickness (mm)	Thickness (inches)	Grade	Max. RPM	Pkg. Qty.
501221	12 x 1/8 x 20mm	3.2	.125	C24R	6,370	5 / 25
501223	12 x 1/8 x 7/8	3.2	.125	C24R	6,370	5 / 25
501225	12 x 1/8 x 1	3.2	.125	C24R	6,370	5 / 25
501227	14 x 1/8 x 1	3.2	.125	C24R	5,400	5 / 25
501229	14 x 1/8 x 20mm	3.2	.125	C24R	5,400	5 / 25



TYPE 1

PROD. NO.	Size (inches)	Thickness (mm)	Thickness (inches)	Grade	Max. RPM	Pkg. Qty.
501320	12 x 5/32 x 20mm	4.0	.156	C16T	6,370	5 / 25
501326	14 x 5/32 x 1	4.0	.156	C16T	5,400	5 / 25
501328	14 x 5/32 x 20mm	4.0	.156	C16T	5,400	5 / 25

Cut-Off Wheels - High Performance (for High Speed Gas Saws)

- These high performance wheels are specially designed to deliver durability, speed, safety and long life required by the rigorous demands of the professional user
- Designed specifically for use in high speed gas saws
- Specially reinforced for added safety during free-hand applications
- 14" wheels are triple reinforced for extra strength and stability
- Not recommended for use on portable chop saws

S  **TYPE 1**

PROD. NO.	Size (inches)	Thickness (mm)	Thickness (inches)	Grade	Max. RPM	Pkg. Qty.
501355	12 x 1/8 x 20mm	3.2	.125	A24R	6,600	5 / 25
501370	14 x 1/8 x 20mm	3.2	.125	A24R	5,500	5 / 25

Con  **TYPE 1**

PROD. NO.	Size (inches)	Thickness (mm)	Thickness (inches)	Grade	Max. RPM	Pkg. Qty.
501356	12 x 1/8 x 20mm	3.2	.125	C24R	6,600	5 / 25
501371	14 x 1/8 x 20mm	3.2	.125	C24R	5,500	5 / 25

POWERPLUS®



501355

**** BETTER**



501356

**** BETTER**





CUT-OFF WHEELS (FOR CHOP SAWS)

POWER ABRASIVE™



GOOD**

501134



Angle Iron



Solid Round
Tubing

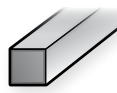

Solid
Square
Tubing

SUPER CHOP®



BEST**

501143

POWER ABRASIVE

Cut-Off Wheels - General Purpose (for Portable Chop Saws)

- These wheels are designed for general purpose cutting of solids, pipe, angle iron, rebar and tubing
- Good cutting performance at an economical price
- **Do not use on high speed gas saws**



TYPE 1

PROD. NO.	Size (inches)	Thickness (mm)	Thickness (inches)	Grade	Max. RPM	Pkg. Qty.
501134	14 x 3/32 x 1	2.5	.094	A36R	4,400	5 / 25

SUPER CHOP

Cut-Off Wheels - Super High Performance (for Portable Chop Saws)

- Designed to offer straight, fast, smooth cutting and a bur free finish
- Best in class wheel life for the toughest applications
- The wheel of choice for all types of materials including solids, angle iron, pipe and rebar
- A Canadian industry leader for over 20 years
- **Do not use on high speed gas saws**



TYPE 1

PROD. NO.	Size (inches)	Thickness (mm)	Thickness (inches)	Grade	Max. RPM	Pkg. Qty.
501143	12 x 3/32 x 1	2.5	.094	A36	5,100	5 / 25
501146	14 x 3/32 x 1	2.5	.094	A36	4,400	5 / 25
501149	16 x 7/64 x 1	2.8	.109	A36	3,700	5 / 25



SUPER CHOP STUD CUT

Cut-Off Wheels - Super High Performance (for Portable Chop Saws)

- Designed to cut steel studs, hollow tubing and other thin wall materials
- Double reinforced for maximum strength and safety
- **Do not use on high speed gas saws**

TYPE 1

PROD. NO.	Size (inches)	Thickness (mm)	Thickness (inches)	Grade	Max. RPM	Pkg. Qty.
501152	12 x 3/32 x 1	2.5	.094	A30R	5,100	5 / 25
501153	14 x 3/32 x 1	2.5	.094	A30R	4,400	5 / 25
501154	16 x 7/64 x 1	2.8	.109	A30R	3,700	5 / 25



Steel Studs



Hollow Round Tubing



Hollow Square Tubing

SUPER CHOP®



501153

BEST**

SUPER CHOP® NF

Cut-Off Wheels - Super High Performance (for Portable Chop Saws)

- Specially formulated to cut a wide variety of aluminum and other non-ferrous materials without material loading on the wheel
- Designed to offer fast effective cutting and long life
- **Do not use on high speed gas saws**

TYPE 1

PROD. NO.	Size (inches)	Thickness (mm)	Thickness (inches)	Grade	Max. RPM	Pkg. Qty.
501166	14 x 3/32 x 1	2.5	.094	A30NF	4,400	5 / 25

SUPER CHOP® NF



501166

BEST**



POWER ABRASIVE™



GOOD**

501233

POWERPLUS®



BETTER**

501273

POWER X-TREME™



BEST**

501336

POWER ABRASIVE

Cut-Off Wheels - General Purpose (for Stationary Cut-Off Machines)

- Designed for general purpose cutting at an economical price
- Ideal for cutting steel materials



TYPE 1

PROD. NO.	Size (inches)	Thickness (mm)	Thickness (inches)	Grade	Max. RPM	Pkg. Qty.
501233	16 x 5/32 x 1	4.0	.156	A24GP	3,820	10
501243	20 x 5/32 x 1	4.0	.156	A24GP	3,000	10

POWERPLUS®

Cut-Off Wheels - High Performance (for Stationary Cut-Off Machines)

- Designed for fast bur free cutting of steel in stationary cut-off machines
- Cuts a wide range of materials from, thin walled profiles to heavy solids
- Specially formulated to offer fast, cool cutting while providing long life



TYPE 1

PROD. NO.	Size (inches)	Thickness (mm)	Thickness (inches)	Grade	Max. RPM	Pkg. Qty.
501283	16 x 5/32 x 1	4.0	.156	A24S	3,500	10
501293	20 x 3/16 x 1	5.0	.190	A24S	3,000	10

POWER-XTREME®

Cut-Off Wheels - Super High Performance (for Stationary Cut-Off Machines)

- POWER-XTREME® super high performance wheels are specially formulated to cut all types of steel and stainless steel
- Fast and cool cutting with minimal burs and discolouration
- Engineered for fast cutting and long life on a variety of applications
- Outperforms aluminum oxide wheels up to 3x in life
- Specially formulated to offer the lowest cost per cut
- Ideal for foundry applications where productivity is essential



TYPE 1

PROD. NO.	Size (inches)	Thickness (mm)	Thickness (inches)	Grade	Max. RPM	Pkg. Qty.
501336	16 x 5/32 x 1	4.0	.156	ZA24S	3,800	10
501346	20 x 3/16 x 1	5.0	.190	ZA24S	3,060	10

WE CARRY 3 QUALITY RANGES TO MEET YOUR PRICING AND PERFORMANCE NEEDS.

Diamond blade performance is determined primarily by segment heights and diamond concentration. The greater the segment height and higher the diamond concentration, the better the blade will perform. Our strict standards ensure maximum performance and productivity.

DIAMOND BLADES FOR ANGLE GRINDERS, CIRCULAR SAWS & TUB SAWS



SEGMENTED



TURBO



CONTINUOUS RIM TILE

Diamond blades have become an important power tool accessory over traditional abrasives, by cutting faster, lasting longer and maintaining their original wheel diameter throughout their life. They have become the cutting tool of choice for concrete and stone applications. All JET diamond blades are designed for dry or wet cutting.

ECONO VALUE SERIES

- Good entry level blade for cost conscious users
- Ideal for first-time and occasional users



PREMIUM CONTRACTOR SERIES

- Contractor grade blade for use on medium to large jobs
- Excellent cutting performance at a reasonable cost
- Ideal for general contractors, construction sites and rental yards



SUPER PREMIUM QUALITY

- Professional grade blade for contractors demanding the ultimate in diamond blade performance
- Specially formulated for fastest cutting, longest blade life and optimal cutting/cost ratio





JET-KUT®

Premium
Contractor Series



568609

Super Premium
Professional Series



567010

JET-KUT® DIAMOND BLADES

Premium Dry Segmented

(for Angle Grinders, Circular Saws, Tub Saws)

- Designed for cutting concrete, masonry materials, red brick, and hard brick



PROD. NO.	MOD. NO.	Size (inches)	Max. RPM	Segment Height (inches)	Pkg. Qty.
568602	DST-4	4 x .080 x 7/8 (5/8)	15,000	.275	1
568609	DST-4.5	4-1/2 x .080 x 7/8 (5/8)	13,300	.275	1
568615	DST-5	5 x .080 x 7/8 (5/8)	12,000	.275	1
568632	DST-7	7 x .080 x 7/8 (5/8)	8,730	.275	1
568643	DST-8	8 x .080 x 7/8 (5/8)	7,640	.275	1
568652	DST-9	9 x .080 x 7/8 (5/8)	6,790	.275	1
568663	DST-10	10 x .080 x 7/8 (5/8)	6,115	.275	1

JET-KUT® DIAMOND BLADES

Super Premium Dry Segmented

(for Angle Grinders, Circular Saws, Tub Saws)

- Designed for cutting cured/reinforced concrete, roof tile, red brick, masonry, hard brick, paving brick, granite and marble
- Manufactured with the most advanced technologies for fast cutting and extra long life



PROD. NO.	MOD. NO.	Size (inches)	Max. RPM	Segment Height (inches)	Pkg. Qty.
567010	SPDST-4.5	4-1/2 x .080 x 7/8 (5/8)	13,300	.275	1
567015	SPDST-5	5 x .080 x 7/8 (5/8)	12,000	.275	1
567025	SPDST-7	7 x .095 x 7/8 (5/8)	8,730	.275	1
567040	SPDST-10	10 x .095 x 7/8 (5/8)	6,115	.275	1

JET-KUT® DIAMOND BLADES

Premium Turbo (for Angle Grinders, Circular Saws, Tub Saws)

- Designed for cutting granite, bricks, tile, roofing tiles, brick and block pavers, refractories, concrete and masonry materials
- Turbo Rim blades feature continuous rim, dry wave cutters for fast, smooth, chip free cutting



PROD. NO.	MOD. NO.	Size (inches)	Max. RPM	Segment Height (inches)	Pkg. Qty.
568603	DDT-4	4 x .095 x 7/8 (5/8)	15,000	.275	1
568611	DDT-4.5	4-1/2 x .095 x 7/8 (5/8)	13,300	.275	1
568617	DDT-5	5 x .095 x 7/8 (5/8)	12,000	.275	1
568633	DDT-7	7 x .095 x 7/8 (5/8)	8,730	.275	1
568645	DDT-8	8 x .095 x 7/8 (5/8)	7,640	.275	1
568655	DDT-9	9 x .095 x 7/8 (5/8)	6,790	.275	1
568666	DDT-10	10 x .102 x 7/8 (5/8)	6,115	.275	1

JET-KUT® DIAMOND BLADES

Super Premium Turbo (for Angle Grinders, Circular Saws, Tub Saws)

- Designed for cutting granite, bricks, tile, roofing tiles, brick and block pavers, refractories, concrete and masonry materials
- Turbo Rim blades feature continuous rim, dry wave cutters for fast, smooth, chip free cutting
- Manufactured with the most advanced technologies for fast cutting and extra long life
- High diamond concentration make these super premium blades fast cutting and extremely long lasting



PROD. NO.	MOD. NO.	Size (inches)	Max. RPM	Segment Height (inches)	Pkg. Qty.
567110	SPDDT-4.5	4-1/2 x .080 x 7/8 (5/8)	13,300	.354	1
567115	SPDDT-5	5 x .080 x 7/8 (5/8)	12,000	.354	1
567125	SPDDT-7	7 x .095 x 7/8 (5/8)	8,730	.354	1
567140	SPDDT-10	10 x .102 x 7/8 (5/8)	6,115	.354	1



JET-KUT®



568611



567115



JET-KUT®



568614



567405



568729

JET-KUT® DIAMOND BLADES

Premium Continuous Rim (for Tile Saws and Angle Grinders)

- Designed for fast, smooth, chip free cutting of ceramic tile



PROD. NO.	MOD. NO.	Size (inches)	Max. RPM	Rim Height (inches)	Pkg. Qty.
568601	TC4-2X	4 x .070 x (5/8)	15,000	.197 (13/64)	1
568614	TC5	5 x .070 x 7/8 (5/8)	12,000	.197 (13/64)	1
568631	TC7-2X	7 x .067 x 7/8 (5/8)	8,730	.197 (13/64)	1
568661	TC10-2X	10 x .095 x 5/8	6,115	.197 (13/64)	1

JET-KUT® DIAMOND BLADES

Super Premium Continuous Rim (for Tile Saws and Angle Grinders)

- Designed for cutting tile, ceramics, granite and thin marble
- High diamond concentration make these super high performance blades fast cutting and extremely long lasting



PROD. NO.	MOD. NO.	Size (inches)	Max. RPM	Rim Height (inches)	Pkg. Qty.
567405	SPTC4	4 x .052 x 5/8	15,000	.295 (19/64)	1
567440	SPTC10	10 x .067 x 5/8	6,115	.295 (19/64)	1

JET-KUT® DIAMOND BLADES

Super Premium Tuck Point (for Angle Grinders)

- Designed for fast efficient removal of mortar joints when restoring or repairing brick buildings



PROD. NO.	MOD. NO.	Size (inches)	Max. RPM	Segment Height (inches)	Number of Rows
568729	TDP04-150	4 x .250 x 7/8 (5/8)	15,000	.275	1
568739	TDP05-1505	5 x .250 x 7/8 (5/8)	12,000	.275	1

JET-KUT® DIAMOND BLADES

Econo Segmented Turbo (for Portable Gas and Electric Saws)

- Designed for cutting cured concrete and masonry
- Ideal for small to medium sized jobs



PROD. NO.	MOD. NO.	Size (inches)	Max. RPM	Segment Height (inches)	Pkg. Qty.
569801	EHS-12C-20M	12 x .110 x 20mm	6,300	.275	1
569811	EHS-14C-20M	14 x .110 x 20mm	5,460	.275	1

JET-KUT® DIAMOND BLADES

Premium Segmented Turbo (for Portable Gas and Electric Saws)

- Designed for cutting cured concrete and masonry
- Designed for medium to large sized jobs



PROD. NO.	MOD. NO.	Size (inches)	Max. RPM	Segment Height (inches)	Pkg. Qty.
568812	HSD-12C	12 x .110 x 1	6,300	.275	1
568814	HSD-12C-20M	12 x .110 x 20mm	6,300	.275	1
568824	HSD-14C	14 x .125 x 1	5,460	.275	1
568826	HSD-14C-20M	14 x .125 x 20mm	5,460	.275	1
568836	HSD-16C	16 x .138 x 1	4,725	.393	1

JET-KUT® DIAMOND BLADES

Premium Segmented Turbo (for Portable Gas and Electric Saws)

- Designed for cutting asphalt and green concrete
- Blade is equipped with undercut protective segments to minimize undercutting of the steel core



PROD. NO.	MOD. NO.	Size (inches)	Max. RPM	Segment Height (inches)	Pkg. Qty.
568815	HSD-12A-20M	12 x .110 x 20mm	6,300	.275	1
568825	HSD-14A	14 x .125 x 1	5,460	.275	1
568827	HSD-14A-20M	14 x .125 x 20mm	5,460	.275	1



JET-KUT®



569801



568812



568825



JET-KUT®



569806



567202



567212

JET-KUT® DIAMOND BLADES

Econo Segmented Turbo (for Portable Gas and Electric Saws)

- Designed for cutting cured concrete
- Turbo dry wave segments for fast, smooth, chip free cutting



PROD. NO.	MOD. NO.	Size (inches)	Max. RPM	Segment Height (inches)	Number of Rows
569806	EFC-12C-20M	12 x .110 x 20mm	6,300	.393	1
569816	EFC-14C-20M	14 x .110 x 20mm	5,460	.393	1

JET-KUT® DIAMOND BLADES

Super Premium Segmented (for Portable Gas and Electric Saws)

- Designed for cutting cured concrete, reinforced cured concrete, paving brick and masonry materials
- High diamond concentrate ensures these super premium blades are fast cutting and extremely long lasting



PROD. NO.	MOD. NO.	Size (inches)	Max. RPM	Segment Height (inches)	Number of Rows
567202	SPHSD-12C-20M	12 x .110 x 20mm	6,300	.275	1
567222	SPHSD-14C-20M	14 x .125 x 20mm	5,460	.275	1

JET-KUT® DIAMOND BLADES

Super Premium Segmented (for Portable Gas and Electric Saws)

- Designed for cutting asphalt over concrete and green concrete
- Blade is equipped with undercut protective segments to minimize undercutting of the steel core



PROD. NO.	MOD. NO.	Size (inches)	Max. RPM	Segment Height (inches)	Number of Rows
567212	SPHSD-12A-20M	12 x .125 x 20mm	6,300	.275	1
567232	SPHSD-14A-20M	14 x .125 x 20mm	5,460	.275	1

CUTTING & GRINDING



POWERPLUS®



BETTER**

500425

POWER XTREME™



BEST**

501653

POWERPLUS® DUO

Depressed Centre Wheels - High Performance Combo (for Angle Grinders)

- These dual purpose wheels are ideal when performing multiple cutting and light grinding tasks without changing wheels. Saving time and money while improving productivity and safety
- Complies with EN 12413 OSA standards – allows side load capacity of +/- 290.n



TYPE 27

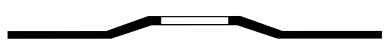

PROD. NO.	Size (inches)	Thickness (mm)	Thickness (inches)	Grade	Max. RPM	Pkg. Qty.
500405	4 x 1/8 x 5/8	3.2	.125	A30DUO	15,300	25
500415	4-1/2 x 1/8 x 7/8	3.2	.125	A30DUO	13,300	25
500425	5 x 1/8 x 7/8	3.2	.125	A30DUO	12,200	25
500431	6 x 1/8 x 7/8	3.2	.125	A30DUO	10,200	25
500435	7 x 1/8 x 7/8	3.2	.125	A30DUO	8,600	25
500445	9 x 1/8 x 7/8	3.2	.125	A30DUO	6,600	25

POWER-XTREME® DUO

(PREVIOUSLY POWERPLUS TZ+ DUO)

Depressed Centre Wheels - Super High Performance Combo (for Angle Grinders)

- Specially designed dual purpose wheels for high performance cutting and light grinding of both steel and stainless steel materials
- Ideal for notching, chamfering, deburring and much more
- Fe+S+Cl free for contamination free cutting and light grinding of stainless steel
- Special reinforcements and pressing technologies allow thin cutting wheels to safely perform light grinding operations without changing wheels, saving time and money
- Complies with EN 12413 OSA standards – allows side load capacity of +/- 290.n
- Designed to cut at 90° and grind at 30°



TYPE 27

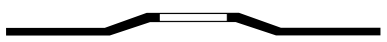

PROD. NO.	Size (inches)	Thickness (mm)	Thickness (inches)	Grade	Max. RPM	Pkg. Qty.
501653	4-1/2 x 5/64 x 7/8	1.9	.075	A46PX-DUO	13,300	25
501656	5 x 5/64 x 7/8	1.9	.075	A46PX-DUO	12,200	25



POWER-XTREME® DUO SST (PREVIOUSLY POWERPLUS DUO)

Depressed Centre Wheels - Super High Performance Combo
(for Angle Grinders)

- Dual purpose wheels are ideal when performing multiple cutting and light grinding tasks without changing wheels. Saving time and money while improving productivity and safety
- Fe+S+Cl free for contamination free cutting and light grinding of stainless steel
- Complies with EN 12413 OSA standards – allows side load capacity of +/- 290.n



**Fe+S+Cl
Free**



TYPE 27

PROD. NO.	Size (inches)	Thickness (mm)	Thickness (inches)	Grade	Max. RPM	Pkg. Qty.
500465	4-1/2 x 1/8 x 7/8	3.2	.125	A30DUO	13,300	25
500475	5 x 1/8 x 7/8	3.2	.125	A30DUO	12,200	25
500481	6 x 1/8 x 7/8	3.2	.125	A30DUO	10,200	25
500485	7 x 1/8 x 7/8	3.2	.125	A30DUO	8,600	25

POWER-XTREME®



500475

BEST**



GRINDING





POWER ABRASIVE™



500805

POWER ABRASIVE™



500720

POWER ABRASIVE

Depressed Centre Wheels - General Purpose (for Die Grinders)

- These small diameter depressed centre wheels are manufactured for grinding steel on all popular 2" air die grinders
- Used for grinding in confined areas

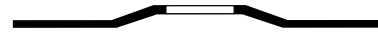

PROD. NO.	Size (inches)	Thickness (mm)	Thickness (inches)	Grade	Max. RPM	Pkg. Qty.
500803	2 x 3/16 x 3/8	5.0	.190	A60	38,200	15
500805	2 x 3/16 x 3/8	5.0	.190	A80	38,200	15

POWER ABRASIVE

Depressed Centre Wheels - General Purpose (for Angle Grinders)

- Ideal for general purpose grinding of all steel materials
- Designed to offer good grinding performance at an economical price
- Special dual grit format (coarse on the face and fine on the back) offers an impressive grinding and finishing combination



PROD. NO.	Size (inches)	Thickness (mm)	Thickness (inches)	Grade	Max. RPM	Pkg. Qty.
500712	4 x 1/4 x 5/8	7.0	.250	A24R	15,300	25
500716	4-1/2 x 1/4 x 7/8	7.0	.250	A24R	13,300	25
500720	5 x 1/4 x 7/8	7.0	.250	A24R	12,300	25
500726	7 x 1/4 x 7/8	7.0	.250	A24R	8,500	25

ANGLE GRINDERS

JET carries a complete range of pneumatic angle grinders to meet the needs of every application. See our Air Tools section for these products.

4" 402304



5" 402305



5" - Heavy Duty 402313



5" - Super Heavy Duty 402312



7" - Heavy Duty 402333



7" - Super Heavy Duty 402332



Depressed Centre Wheels - High Performance (for Angle Grinders)

- Specially formulated for high performance grinding in a wide range of steel operations
- Made with high quality abrasive grains for faster grinding results with less effort
- New improved formula offers 20% improved grinding performance



TYPE 27

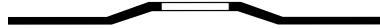

PROD. NO.	Size (inches)	Thickness (mm)	Thickness (inches)	Grade	Max. RPM	Pkg. Qty.
500408	4 x 1/4 x 5/8	7.0	.250	A24R	15,300	25
500418	4-1/2 x 1/4 x 7/8	7.0	.250	A24R	13,300	25
500428	5 x 1/4 x 7/8	7.0	.250	A24R	12,200	25
500432	6 x 1/4 x 7/8	7.0	.250	A24R	10,200	25
500438	7 x 1/4 x 7/8	7.0	.250	A24R	8,600	25
500448	9 x 1/4 x 7/8	7.0	.250	A24R	6,600	25

PROD. NO.		Pkg. Qty.
500408A01	Same as 500408 in a clamshell package	1
500418A01	Same as 500418 in a clamshell package	1
500428A01	Same as 500428 in a clamshell package	1



POWERPLUS®



500418



POWERPLUS® SST

Depressed Centre Wheels - High Performance (for Angle Grinders)

- Specially formulated wheels offer the longest life and best performance when grinding stainless steel and other hard materials
- Made from highly refined ingredients; these wheels will not contaminate stainless steel
- Designed to offer outstanding stock removal rates, long wheel life and cool, burn free cutting
- POWERPLUS® SST wheels are the best solution where certified contamination free wheels are required
- Manufactured in Europe; these wheels offer extra fast stock removal and long wheel life



TYPE 27



PROD. NO.	Size (inches)	Thickness (mm)	Thickness (inches)	Grade	Max. RPM	Pkg. Qty.
500468	4-1/2 x 1/4 x 7/8	7.0	.250	A30SS	13,300	25
500478	5 x 1/4 x 7/8	7.0	.250	A30SS	12,200	25
500482	6 x 1/4 x 7/8	7.0	.250	A30SS	10,200	25
500488	7 x 1/4 x 7/8	7.0	.250	A30SS	8,600	25

POWERPLUS® SST



500478





POWERPLUS® CON



BETTER**

500528

POWERPLUS® NF



BETTER**

500578

POWERXTREME®



BEST**

500928

POWERPLUS® CON

Depressed Centre Wheels - High Performance (for Angle Grinders)

- Specially designed for grinding of concrete, stone and masonry
- Made from extremely sharp silicon carbide grains for fast stock removal and a smooth finish



TYPE 27

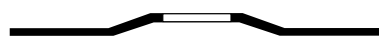

PROD. NO.	Size (inches)	Thickness (mm)	Thickness (inches)	Grade	Max. RPM	Pkg. Qty.
500518	4-1/2 x 1/4 x 7/8	7.0	.250	C24	13,300	25
500528	5 x 1/4 x 7/8	7.0	.250	C24	12,200	25
500538	7 x 1/4 x 7/8	7.0	.250	C24	8,600	25

POWERPLUS® NF

Depressed Centre Wheels - High Performance (for Angle Grinders)

- Specially formulated to grind a wide variety of aluminum and other non-ferrous materials without loading
- Specially formulated grains offer extra fast stock removal and long wheel life



TYPE 27

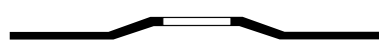

PROD. NO.	Size (inches)	Thickness (mm)	Thickness (inches)	Grade	Max. RPM	Pkg. Qty.
500568	4-1/2 x 1/4 x 7/8	7.0	.250	AL24	13,300	25
500578	5 x 1/4 x 7/8	7.0	.250	AL24	12,200	25
500588	7 x 1/4 x 7/8	7.0	.250	AL24	8,600	25

POWERXTREME®

Depressed Centre Wheels

Super High Performance (for Angle Grinders)

- These super high performance grinding wheels are designed to deliver fast stock removal rates and "Xtreme" wheel life for increased productivity and performance
- Ideal for foundry and all other heavy grinding applications where productivity is essential
- Made with high quality abrasive grains for faster grinding results with less effort



TYPE 27

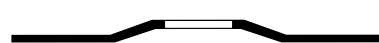

PROD. NO.	Size (inches)	Thickness (mm)	Thickness (inches)	Grade	Max. RPM	Pkg. Qty.
500918	4-1/2 x 1/4 x 7/8	7.0	.250	ZA24S	13,300	25
500928	5 x 1/4 x 7/8	7.0	.250	ZA24S	12,200	25
500932	6 x 1/4 x 7/8	7.0	.250	ZA24S	10,200	25
500938	7 x 1/4 x 7/8	7.0	.250	ZA24S	8,600	25
500948	9 x 1/4 x 7/8	7.0	.250	ZA24S	6,600	25

BENCH GRINDING WHEELS - VITRIFIED

Aluminum Oxide - General Purpose

- For general purpose grinding of steel on bench and pedestal grinders
- All 6", 7", and 8" wheels are supplied with telescoping bushings from 1" through 1/2" to fit most bench grinders
- Please refer to 599033 and 599045 for information on bushings

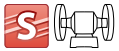

PROD. NO.	Size (inches)	Grade	Max. RPM
522163	6 x 3/4 x 1	A36 - coarse	4,138
522164	6 x 3/4 x 1	A46 - medium	4,138
522165	6 x 3/4 x 1	A60 - fine	4,138
522173	6 x 1 x 1	A36 - coarse	4,138
522174	6 x 1 x 1	A46 - medium	4,138
522175	6 x 1 x 1	A60 - fine	4,138
522176	6 x 1 x 1	A80 - very fine	4,138
522224	7 x 1 x 1	A46 - medium	3,600
522225	7 x 1 x 1	A60 - fine	3,600
522263	8 x 3/4 x 1	A36 - coarse	3,600
522264	8 x 3/4 x 1	A46 - medium	3,600
522265	8 x 3/4 x 1	A60 - fine	3,600
522273	8 x 1 x 1	A36 - coarse	3,600
522274	8 x 1 x 1	A46 - medium	3,600
522275	8 x 1 x 1	A60 - fine	3,600
522313	10 x 1 x 1	A36 - coarse	2,483
522314	10 x 1 x 1	A46 - medium	2,483
522315	10 x 1 x 1	A60 - fine	2,483
522333	10 x 1-1/2 x 1-1/4	A36 - coarse	2,483
522334	10 x 1-1/2 x 1-1/4	A46 - medium	2,483
522335	10 x 1-1/2 x 1-1/4	A60 - fine	2,483
522372	12 x 2 x 1-1/2	A24 - extra coarse	2,069
522373	12 x 2 x 1-1/2	A36 - coarse	2,069
522374	12 x 2 x 1-1/2	A46 - medium	2,069
522375	12 x 2 x 1-1/2	A60 - fine	2,069



522165





522436



522514



599033



599045

BENCH GRINDING WHEELS - VITRIFIED

Green Silicon Carbide (for Bench Grinders)

- For grinding carbide and non-ferrous tools on bench grinders and pedestal grinders
- Made from high quality sharp silicon carbide grain
- Ideal for grinding tungsten carbide
- All 6" and 8" wheels are supplied with telescoping bushings from 1" through 1/2"
- Please refer to 599033 and 599045 for information on bushings



PROD. NO.	Size (inches)	Grade	Max. RPM
522406	6 x 3/4 x 1	GC60 - coarse	4,138
522407	6 x 3/4 x 1	GC80 - medium	4,138
522409	6 x 3/4 x 1	GC120 - fine	4,138
522411	6 x 1 x 1	GC60 - coarse	4,138
522412	6 x 1 x 1	GC80 - medium	4,138
522414	6 x 1 x 1	GC120 - fine	4,138
522436	8 x 1 x 1	GC60 - coarse	3,600
522437	8 x 1 x 1	GC80 - medium	3,600
522439	8 x 1 x 1	GC120 - Fine	3,600

BENCH GRINDING WHEELS - VITRIFIED

White Aluminum Oxide (for Bench Grinders)

- Made from high quality white aluminum oxide grains that are sharper and cooler cutting than regular aluminum oxide grains
- Ideal for grinding drill bits and other hardened steel and alloy cutting tools where over-heating will affect temper
- All wheels are supplied with telescoping bushings from 1" through 1/2"
- Please refer to 599033 and 599045 for information on bushings



PROD. NO.	Size (inches)	Grade	Max. RPM
522502	6 x 3/4 x 1	WA60 - coarse	4,138
522506	6 x 1 x 1	WA60 - coarse	4,138
522514	8 x 1 x 1	WA60 - coarse	3,600

BUSHINGS

- Bushings for bench grinding wheel available separately

599033

Contains 5 bushings listed
Width x Outside Diameter x
Inside Diameter:

- 1) 1/2" x 1-1/4" x 1"
- 2) 1/2" x 1" x 7/8"
- 3) 1/2" x 7/8" x 3/4"
- 4) 1/2" x 3/4" x 5/8"
- 5) 1/2" x 5/8" x 1/2"

599045

Contains 4 bushings listed
Width x Outside Diameter x
Inside Diameter:

- 1) 1" x 1-1/2" x 1-1/4"
- 2) 1" x 1-1/4" x 1"
- 3) 1" x 1" x 3/4"
- 4) 1" x 3/4" x 5/8"

MOUNTED POINTS - VITRIFIED

General Purpose (for Die Grinders)

- Made from the finest grades of abrasive grains; these points are used on air and electric die grinders for fitting, shaping, enlarging holes and finishing work in confined spaces
- 1/4" shank for easy mounting on die grinders

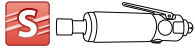

PROD. NO.	Size (inches)	Shape	Max. RPM
510100	3/4 x 2-1/2	A1	19,800
510110	1 x 2-3/4	A3	16,100
510120	3/4 x 1-1/8	A5	45,000
510150	7/8 x 2	A11	19,860
510215	1/4 x 3/4	A24	76,500
510275	1-5/8 x 3/8	A36	23,520
510285	1 x 1	A38	34,500
510290	3/4 x 3/4	A39	47,250
510524	1/2 x 1-1/2	W188	30,370
510556	1 x 1	W220	25,550

CUP WHEELS

High Performance (for Angle Grinders)

- JET's wide range of T-11 resin bonded cup wheels are used for rough grinding on concrete, stone or steel
- All sizes and grits are supplied with a wrap-around steel hub for maximum safety and long life
- 5/8" - 11NC arbor for easy mounting



PROD. NO.	Size (inches)	Shape	Grit	Max. RPM	Pkg. Qty.
523206	4 x 2 x 5/8-11NC	T11	C8	9,000	10
523216	5 x 2 x 5/8-11NC	T11	C8	7,200	10
523217	5 x 2 x 5/8-11NC	T11	C16	7,200	10
523226	6 x 2 x 5/8-11NC	T11	C8	6,000	10



PROD. NO.	Size (inches)	Shape	Grit	Max. RPM	Pkg. Qty.
523201	4 x 2 x 5/8-11NC	T11	A16	9,000	10
523211	5 x 2 x 5/8-11NC	T11	A16	7,200	10
523221	6 x 2 x 5/8-11NC	T11	A16	6,000	10



523221 / 523216



523446
Type 16



523449
Type 18



523450
Type 18R



523303

PLUG STONES

High Performance (for End Grinders)

- Used on high speed, portable end grinders for grinding, shaping, cleaning castings, blending and deburring of internal and external contours
- Internal threaded arbor for easy direct mounting

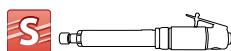

PROD. NO.	Size (inches)	Shape	Grit	Max. RPM	Pkg. Qty.
523436	1-1/2 x 3 x 5/8NC	T16	A20	24,200	10
523439	1-1/2 x 3 x 5/8NC	T18	A20	24,200	10
523440	1-1/2 x 3 x 5/8NC	T18R	A20	24,200	10
523446	2 x 3 x 5/8NC	T16	A20	18,100	10
523449	2 x 3 x 5/8NC	T18	A20	18,100	10
523450	2 x 3 x 5/8NC	T18R	A20	18,100	10
523454	2 x 4 x 5/8NC	T18	A20	18,100	10
523455	2 x 4 x 5/8NC	T18R	A20	18,100	10
523480	3 x 4 x 5/8NC	T18R	A20	12,100	10

RESIN BOND STRAIGHT WHEELS

High Performance (for End Grinders)

- Ideal for heavy weld preparation, casting clean-up and many other applications
- For use on all air and electric die grinders and straight shaft end grinders
- Use with 599024 mandrel

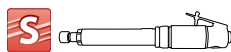

PROD. NO.	Size (inches)	Shape	Grit	Max. RPM	Pkg. Qty.
523303	1-1/2 x 1/2 x 3/8	T1	A36	36,000	10
523309	2 x 1/2 x 3/8	T1	A36	27,120	10



* Use 599024 1/4" mandrel for wheels 3/8" - 1/2" thickness



DRY SEGMENTED DIAMOND CUP WHEELS

JET-KUT® DIAMOND CUP WHEELS

Premium (for Angle Grinders)

- Dry cutting diamond cup wheels grind and finish concrete, masonry, and stone at an extremely fast rate
- 5" and 7" available in single and double row for faster material removal and longer wheel life
- For use on angle grinders – 5/8-11NC



PROD. NO.	MOD. NO.	Size (inches)	Max. RPM	Number of rows	Pkg. Qty.
568501	DSW-4C	4 x 5/8-11NC	15,000	Single	1
568503	DSW-5C	5 x 5/8-11NC	12,000	Single	1
568504	DDW-5C	5 x 5/8-11NC	12,000	Double	1
568507	DSW-7C	7 x 5/8-11NC	8,730	Single	1
568508	DSW-7D	7 x 5/8-11NC	8,730	Double	1

JET-KUT®



568503



PIONEER
Performance

PIONEER
Performance

BLENDING & SANDING



POWERBLEND®



POWERBLEND

Flap Discs High Performance (for Angle Grinders)

- Premium high performance zirconia grain discs ensure fast, cool cutting action and extra long life on steel and stainless steel
- Exceptional durability, POWERBLEND flap discs outlast traditional resin fibre discs up to 25 times - saving time and money
- Convex fibreglass backing allows total use of the flaps without damage to the workpiece
- This type 29 flap disc is mounted using regular depressed centre wheel adapters



TYPE 29

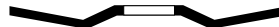

PROD. NO.	Size (inches)	Grit	Max. RPM	Pkg. Qty.
503213	4-1/2 x 7/8	Z40	13,300	10
503215	4-1/2 x 7/8	Z60	13,300	10
503217	4-1/2 x 7/8	Z80	13,300	10
503219	4-1/2 x 7/8	Z120	13,300	10
503223	5 x 7/8	Z40	12,200	10
503225	5 x 7/8	Z60	12,200	10
503227	5 x 7/8	Z80	12,200	10
503229	5 x 7/8	Z120	12,200	10
503231	6 x 7/8	Z40	10,200	10
503233	6 x 7/8	Z60	10,200	10
503235	6 x 7/8	Z80	10,200	10
503237	6 x 7/8	Z120	10,200	10
503238	7 x 7/8	Z40	8,600	10
503240	7 x 7/8	Z60	8,600	10
503242	7 x 7/8	Z80	8,600	10
503244	7 x 7/8	Z120	8,600	10

PROD. NO.		Pkg. Qty.
503213A01	Same as 503213 in a clamshell package	1
503215A01	Same as 503215 in a clamshell package	1
503217A01	Same as 503217 in a clamshell package	1
503223A01	Same as 503223 in a clamshell package	1
503225A01	Same as 503225 in a clamshell package	1
503227A01	Same as 503227 in a clamshell package	1

POWERBLEND TRM

Trimable Flap Discs High Performance (for Angle Grinders)

- These premium high performance zirconia grain discs ensure fast, cool cutting action and extra long life on steel and stainless steel
- Exceptional durability, POWERBLEND TRM discs outlast traditional resin fibre discs up to 25 times - saving time and money
- The raised hub, polymer backing allows the operator to trim away the backing as the outside contact area of the abrasive flap is worn away - this feature allows total use of the abrasive flaps before discarding the wheel
- The special polymer backing will not contaminate the work piece
- Ideal for a wide range of metal fabricating and finishing operations



TYPE 29

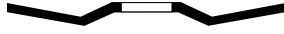

PROD. NO.	Size (inches)	Grit	Max. RPM	Pkg. Qty.
503413	4-1/2 x 7/8	Z40	13,300	10
503415	4-1/2 x 7/8	Z60	13,300	10
503417	4-1/2 x 7/8	Z80	13,300	10
503419	4-1/2 x 7/8	Z120	13,300	10
<hr/>				
503423	5 x 7/8	Z40	12,250	10
503425	5 x 7/8	Z60	12,250	10
503427	5 x 7/8	Z80	12,250	10
503429	5 x 7/8	Z120	12,250	10



POWERBLEND® TRM



503413



POWERBLEND® TRM

INCREASE PRODUCTIVITY

POWERBLEND TRM discs outlast traditional resin fibre discs up to 25 times - saving time and money



POWERBLEND® FLX



BETTER**

503313



BEST**

503915

POWERBLEND FLX

Zirconia Flexible Flap Discs High Performance (for Angle Grinders)

- The unique "cushion style" pointed flap configuration overhanging the fibre back plate offers maximum flexibility, excellent for contoured surfaces, 90° corners, hard-to-reach areas and flat surfaces where a premium finish is critical
- Specially developed to perform applications that cannot be easily accomplished by conventional forms of coated abrasives and more rigid flap discs. Interrupted flap design resists glazing and material loading
- High performance Zirconia grain ensures fast, cool cutting action and extra long life on steel and stainless steel
- Mounted using regular depressed centre wheel adapters



TYPE 27



PROD. NO.	Size (inches)	Grit	Max. RPM	Pkg. Qty.
503313	4-1/2 x 7/8	Z40	13,300	10
503315	4-1/2 x 7/8	Z60	13,300	10
503317	4-1/2 x 7/8	Z80	13,300	10
503319	4-1/2 x 7/8	Z120	13,300	10

POWERBLEND NF

Flap Discs - Super High Performance (for Angle Grinders)

- These super high performance flap discs are specially designed for fast effective grinding of aluminum and other non-ferrous metals
- POWERBLEND NF is uniquely designed with double layer zirconia and specially coated aluminum oxide flaps for optimal grinding performance and wheel life
- The specially formulated coating is designed to eliminate material loading when grinding, allowing the user to gain the most performance before discarding the wheel



TYPE 29



PROD. NO.	Size (inches)	Grit	Max. RPM	Pkg. Qty.
503915	4-1/2 x 7/8	Z60	13,300	10
503925	5 x 7/8	Z60	12,200	10

**POWERBLEND® NF
DESIGNED FOR FAST & EFFECTIVE
ALUMINUM GRINDING**





POWERBLEND EDG

Curved Edge Flap Disc - Super High Performance
(for Angle Grinders)

- POWERBLEND EDG Super High Performance flap discs are specially designed to achieve optimal grinding results for fillet welds, corners and other difficult to reach places
- Flaps are folded upwards at a 90° angle enabling optimal adjustment to the work piece geometry thereby achieving better grinding results in hard-to-reach places without compromising safety to the operator
- Made from specially formulated ceramic grains that are designed to stay sharp, ensuring faster stock removal rates and extreme wheel life
- POWERBLEND EDG ceramic grain flap discs offer up to 70% greater grinding performance over traditional zirconia products



BEST

Watch the video!
yourproclub.com



PROD. NO.	Size (inches)	Grit	Max. RPM	Pkg. Qty.
503865	4-1/2 x 7/8	CG60	13,300	10
503875	5 x 7/8	CG60	12,200	10

POWERBLEND® EDG
FILLET & CORNER GRINDING
MADE EASY



POWERBLEND®



BETTER**

502015

POWERBLEND® FLX



BETTER**

502073

POWERBLEND

Roll-On Flap Discs High Performance Type R (for Die Grinders)

- POWERBLEND 2" and 3" roll-on zirconia flap disc ensure fast, cool cutting action and extra long life on steel and stainless steel
- Compatible with all roll-on (type R) mounting systems
- The quick change roll-on system makes changing discs easy and fast, saving time and increasing productivity
- Cost effective, outlasts regular cloth backed mini discs up to 25 times
- Overlapping layers of coated abrasive material provide longer intervals between disc changes
- Used for high performance grinding, blending and finishing operations in confined areas



ROLL-ON

PROD. NO.	Size (inches)	Grit	Max. RPM	Pkg. Qty.
502011	2	Z40	30,000	10
502013	2	Z60	30,000	10
502015	2	Z80	30,000	10
502017	2	Z120	30,000	10
502021	3	Z40	20,000	10
502023	3	Z60	20,000	10
502025	3	Z80	20,000	10
502027	3	Z120	20,000	10

POWERBLEND FLX

Roll-On Flap Discs High Performance Type R (for Die Grinders)

- POWERBLEND FLX roll-on discs offer a premium 2" and 3" zirconia flap disc for use on die grinders
- The unique "cushion style" beveled edge flap configuration offers maximum flexibility, excellent for contoured surfaces, 90° corners, hard-to-reach areas and flat surfaces where a premium finish is critical
- Compatible with all roll-on (type R) mounting systems
- The quick change roll-on system makes changing discs easy and fast, saving time and increasing productivity
- Specially developed to provide finishes that can not be easily accomplished by conventional forms of coated abrasives and more rigid flap discs.
- Interrupted flap design resists glazing and material loading
- High performance zirconia grain ensures fast, cool cutting action and extra long life on steel and stainless steel



ROLL-ON

PROD. NO.	Size (inches)	Grit	Max. RPM	Pkg. Qty.
502061	2	Z40	30,000	10
502063	2	Z60	30,000	10
502065	2	Z80	30,000	10
502067	2	Z120	30,000	10
502071	3	Z40	20,000	10
502073	3	Z60	20,000	10
502075	3	Z80	20,000	10
502077	3	Z120	20,000	10

ALUMINUM OXIDE CLOTH SANDING DISCS

Roll-On General Purpose Type R (for Die Grinders)

- These cloth discs are ideal for grinding, blending, rust and scale removal, and deburring, on all types of metal
- The tough, cloth backing on these discs are made with quality resin bonding agents and aluminum oxide grains, tear resistant cloth backing for increased stock removal and long life
- Compatible with all roll-on (type R) mounting systems
- The quick change roll-on system makes changing discs easy and fast, saving time and increasing productivity



ROLL-ON

PROD. NO.	Size (inches)	Grit	Max. RPM	Pkg. Qty.
502122	2	36	30,000	100
502124	2	50	30,000	100
502126	2	80	30,000	100
502127	2	100	30,000	100
502128	2	120	30,000	100
502130	2	180	30,000	100
502132	2	240	30,000	100
.....				
502142	3	36	20,000	100
502144	3	50	20,000	100
502146	3	80	20,000	100
502147	3	100	20,000	100
502148	3	120	20,000	100
502150	3	180	20,000	100
502152	3	240	20,000	100

ZIRCONIA ALUMINA CLOTH SANDING DISCS

Roll-On High Performance Type R (for Die Grinders)

- High performance discs are made with tough zirconia alumina grain. They last longer and cut faster and cooler than regular aluminum oxide discs
- Used for fast grinding, blending and finishing of all metals including steel, stainless steel and titanium
- Compatible with all roll-on (type "R") mounting systems
- The quick change roll-on system makes changing discs easy and fast, saving time and increasing productivity

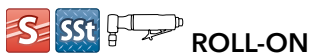

ROLL-ON

PROD. NO.	Size (inches)	Grit	Max. RPM	Pkg. Qty.
502172	2	36	30,000	100
502174	2	50	30,000	100
502176	2	80	30,000	100
.....				
502182	3	36	20,000	100
502184	3	50	20,000	100
502186	3	80	20,000	100

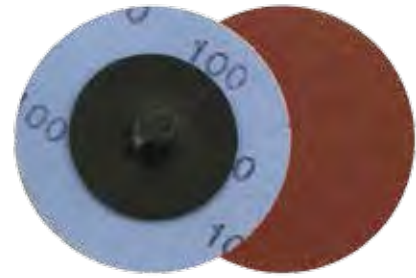

502127

*
GOOD



502176

BEST



BACK-UP PADS for Roll-On Type System (for Die Grinders)

- Back-up pads for use with all types of roll-on products



ROLL-ON

PROD. NO.	Size (inches)	Mounting Style	Max. RPM	Pkg. Qty.
502332	2	1/4" shank	30,000	1
502333	3	1/4" shank	20,000	1
502997	2	1/4" - 20 UNC thread	30,000	1
502998	3	1/4" - 20 UNC thread	20,000	1



DIE GRINDERS

JET carries a complete range of pneumatic die grinders to meet the needs of every application. See our Air Tools section for more information.

.6 HP 1/4" 90° Angle Head
402113



.6 HP 1/4" Mini - Heavy Duty
402114



.6 HP 1/4" 3" Extended - Heavy Duty
402121



.6 HP 1/4" 6" Extended - Heavy Duty
402115



.9 HP 1/4" Die Grinder - Heavy Duty
402123



.9 HP 1/4" 6" Extended - Heavy Duty
402124



FLAP WHEELS

Aluminum Oxide Mandrel Mounted High Performance (for Die Grinders)

- These flapwheels are made of high quality abrasive cloth ideal for general purpose sanding, blending, shaping, cleaning, and deburring on curved, irregular and other hard to reach surfaces
- Mounted on 1/4" spindle for use with die grinders and drills
- Ensure to check that RPM rating of the flapwheel is greater than that of the tool



PROD. NO.	Size (inches)	Grit	Max. RPM	Pkg. Qty.
560122	1 x 1	60	30,000	10
560123	1 x 1	80	30,000	10
560125	1 x 1	120	30,000	10
560127	1 x 1	180	30,000	10
560152	1-1/2 x 1/2	60	25,000	10
560153	1-1/2 x 1/2	80	25,000	10
560155	1-1/2 x 1/2	120	25,000	10
560172	1-1/2 x 1	60	25,000	10
560173	1-1/2 x 1	80	25,000	10
560175	1-1/2 x 1	120	25,000	10
560212	2 x 3/4	60	25,000	10
560213	2 x 3/4	80	25,000	10
560215	2 x 3/4	120	25,000	10
560222	2 x 1	60	25,000	10
560223	2 x 1	80	25,000	10
560225	2 x 1	120	25,000	10
560272	2-1/2 x 1	60	20,000	10
560273	2-1/2 x 1	80	20,000	10
560275	2-1/2 x 1	120	20,000	10
560322	3 x 1	60	20,000	10
560323	3 x 1	80	20,000	10
560325	3 x 1	120	20,000	10
560342	3 x 2	60	12,000	10
560343	3 x 2	80	12,000	10
560345	3 x 2	120	12,000	10



560123



560222





*** GOOD**

564811



*** GOOD**

564863

10 YARD CLOTH SHOP ROLLS

General Purpose

- Made with tough aluminum oxide grain on a flexible cloth backing for maximum resistance to wear
- Ideal for general purpose sanding and deburring, surface cleaning and finishing on a wide variety of metal products
- These compact shop rolls are the ideal size for carrying in tool boxes



PROD. NO.	Dimensions (Inches x Yards)	Grit	Pkg. Qty.
564810	1 x 10	60	1
564811	1 x 10	80	1
564812	1 x 10	100	1
564813	1 x 10	120	1
564814	1 x 10	150	1
564815	1 x 10	180	1
564817	1 x 10	240	1
564818	1 x 10	320	1

50 YARD CLOTH SHOP ROLLS

General Purpose

- High quality aluminum oxide grain, backing and resin bonds make these shop rolls ideal for multiple uses
- Excellent for lathe work and general purpose cleaning and deburring on a wide variety of metal products



PROD. NO.	Dimensions (Inches x Yards)	Grit	Pkg. Qty.
564830	1 x 50	60	1
564831	1 x 50	80	1
564832	1 x 50	100	1
564833	1 x 50	120	1
564835	1 x 50	180	1
564837	1 x 50	240	1
564838	1 x 50	320	1
<hr/>			
564840	1-1/2 x 50	60	1
564841	1-1/2 x 50	80	1
564842	1-1/2 x 50	100	1
564843	1-1/2 x 50	120	1
564845	1-1/2 x 50	180	1
564847	1-1/2 x 50	240	1
564848	1-1/2 x 50	320	1
<hr/>			
564860	2 x 50	60	1
564861	2 x 50	80	1
564862	2 x 50	100	1
564863	2 x 50	120	1
564865	2 x 50	180	1
564867	2 x 50	240	1
564868	2 x 50	320	1

50 YARD RESIN BOND SHOP ROLLS

Premium

- Premium quality aluminum oxide abrasive grain with J cloth backing and full resin bond system for long life and flexibility
- 50 yards packaged in dispenser box making it easy to access and store
- Fast cut rate, excellent wear resistance with superior handling
- Used in various applications: sanding, polishing, light removal, de-burring, blending, surface cleaning and finishing
- Ideal for machine shops, maintenance and manufacturing plants
- For metalworking, woodworking and MRO industries



PROD. NO.	Dimensions (Inches x Yards)	Grit	Pkg. Qty.
564870	1 x 50	60	1
564871	1 x 50	80	1
564872	1 x 50	100	1
564873	1 x 50	120	1
564875	1 x 50	180	1
564876	1 x 50	240	1
564878	1 x 50	320	1
<hr/>			
564880	2 x 50	60	1
564881	2 x 50	80	1
564882	2 x 50	100	1
564883	2 x 50	120	1
564885	2 x 50	180	1
564886	2 x 50	240	1
564888	2 x 50	320	1



564880

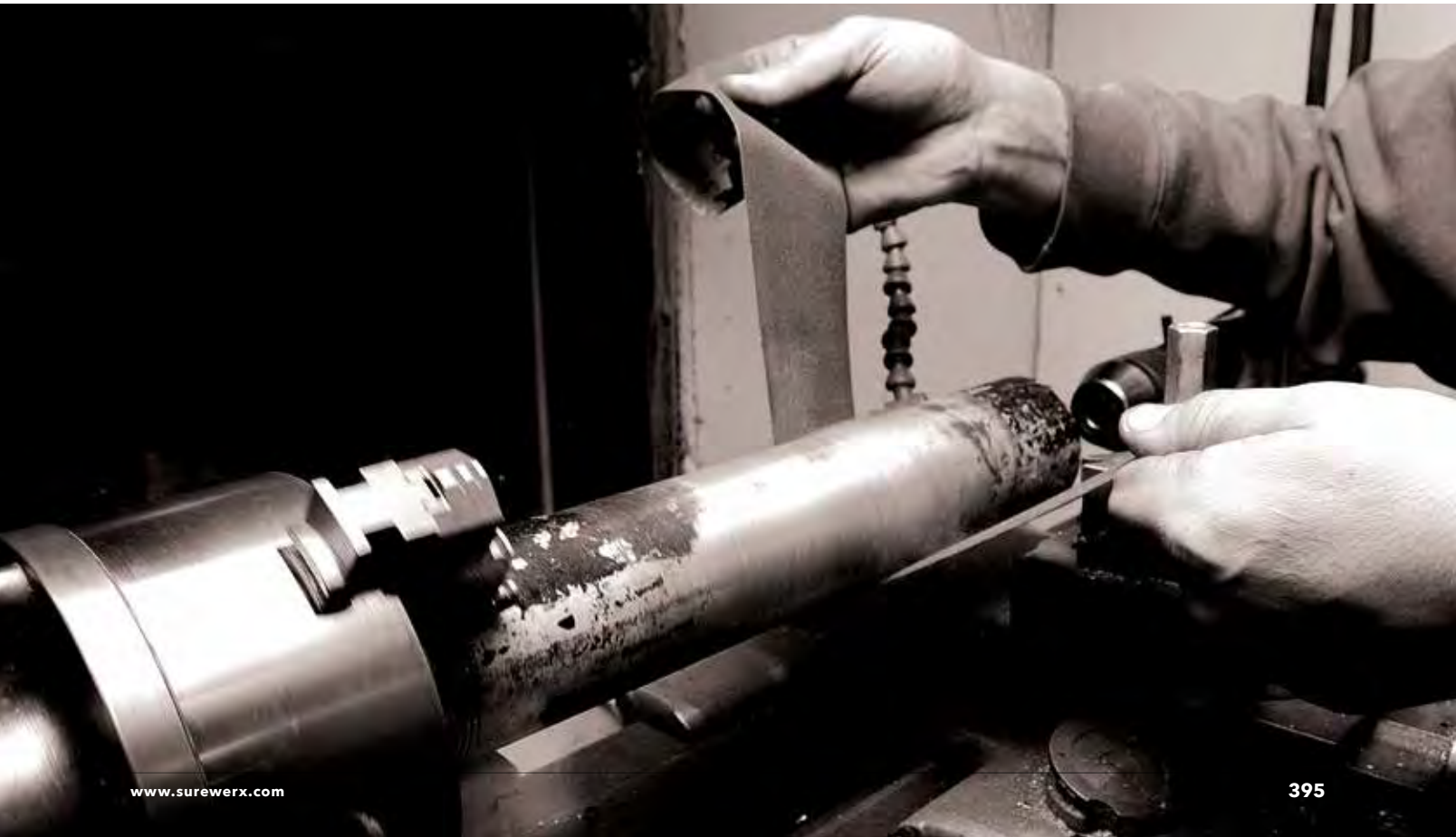



502412

RESIN FIBRE SANDING DISCS

Aluminum Oxide General Purpose (for Angle Grinders)

- JET aluminum oxide discs are the standard in the metalworking industry and popular for general purpose sanding, light weld removal, surface cleaning and finishing
- Excellent for use on all metal grinding and finishing applications, rust and scale removal and deburring operations
- Use with resin fibre disc back-up pads



PROD. NO.	Size (Inches)	Grit	Pkg. Qty.
502402	4 x 5/8	24	25 / 100
502403	4 x 5/8	36	25 / 100
502404	4 x 5/8	50	25 / 100
502406	4 x 5/8	80	25 / 100
502408	4 x 5/8	120	25 / 100

502411	4-1/2 x 7/8	16	25 / 100
502412	4-1/2 x 7/8	24	25 / 100
502413	4-1/2 x 7/8	36	25 / 100
502414	4-1/2 x 7/8	50	25 / 100
502415	4-1/2 x 7/8	60	25 / 100
502416	4-1/2 x 7/8	80	25 / 100
502418	4-1/2 x 7/8	120	25 / 100

502421	5 x 7/8	16	25 / 100
502422	5 x 7/8	24	25 / 100
502423	5 x 7/8	36	25 / 100
502424	5 x 7/8	50	25 / 100
502425	5 x 7/8	60	25 / 100
502426	5 x 7/8	80	25 / 100
502428	5 x 7/8	120	25 / 100

502441	7 x 7/8	16	25 / 100
502442	7 x 7/8	24	25 / 100
502443	7 x 7/8	36	25 / 100
502444	7 x 7/8	50	25 / 100
502445	7 x 7/8	60	25 / 100
502446	7 x 7/8	80	25 / 100
502448	7 x 7/8	120	25 / 100

- Resin fibre discs are sold in package quantities or multiples thereof



PROD. NO.		Pkg. Qty.
502412A05	Same as 502412 in a clamshell package	5
502413A05	Same as 502413 in a clamshell package	5
502414A05	Same as 502414 in a clamshell package	5
502416A05	Same as 502416 in a clamshell package	5
502422A05	Same as 502422 in a clamshell package	5
502423A05	Same as 502423 in a clamshell package	5
502424A05	Same as 502424 in a clamshell package	5
502426A05	Same as 502426 in a clamshell package	5

RESIN FIBRE SANDING DISCS

Zirconia Alumina High Performance (for Angle Grinders)

- Zirconia alumina is a well established, high performance grain and is popular where productivity and life are the important factors
- This very sharp, tough grain offers long life and aggressive cool cutting action
- Excellent for heavy weld and metal grinding of steel and stainless steel materials
- Ideal for medium to heavy pressure grinding
- Use with resin fibre disc back-up pads



PROD. NO.	Size (Inches)	Grit	Pkg. Qty.
502506	4-1/2 x 7/8	Z24	25 / 100
502507	4-1/2 x 7/8	Z36	25 / 100
502508	4-1/2 x 7/8	Z50	25 / 100
502512	5 x 7/8	Z24	25 / 100
502513	5 x 7/8	Z36	25 / 100
502514	5 x 7/8	Z50	25 / 100
502527	7 x 7/8	Z24	25 / 100
502528	7 x 7/8	Z36	25 / 100
502529	7 x 7/8	Z50	25 / 100

POWERFLEX

Semi Flexible Discs High Performance (for Angle Grinders)

- Specially designed for grinding and finishing concrete, stone, hard building materials and fiberglass
- Made from extremely sharp silicon carbide grains for fast cutting and long wheel life
- Manufactured by attaching multiple layers of silicone carbide to a semi-flexible fibre backing
- Spiral grooves in the abrasive coating provides quick clearing of ground-off stock
- Multiple cooling holes reduce the build-up of heat during grinding operations, greatly extending the life of the disc
- The type 29 convex profile helps prevent gouging of the work piece and reduces operator fatigue by making it easier to maintain correct grinding angle
- Mount to angle grinders using standard resin fibre disc back-up pads and nuts



TYPE 29

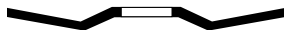

PROD. NO.	Size (inches)	Grit	Max. RPM	Pkg. Qty.
500211	4-1/2 x 7/8	C16	13,300	25
500212	4-1/2 x 7/8	C24	13,300	25
500221	5 x 7/8	C16	12,200	25
500222	5 x 7/8	C24	12,200	25
500241	7 x 7/8	C16	8,600	25
500242	7 x 7/8	C24	8,600	25



502514

POWERFLEX®



500221



502328

ADJUSTABLE PIN WRENCH

- Unique adjustable pin wrench fits all makes of pad nuts

PROD. NO.	Description	Pkg. Qty.
502328	Adjustable pin wrench	1



502354

TURBO STYLE BACK-UP PADS

- Turbo vanes and air holes provide lower working temperatures for longer disc and pad life
- High impact plastic construction delivers rapid heat dissipation for reduced marring of the workpiece
- Excellent value and superior performance
- Each pad shipped complete with flange nut

PROD. NO.	Size (inches)	Nut Size	Max. RPM	Pkg. Qty.
502352	4-1/2	5/8 -11NC	20,000	1
502353	5	5/8 -11NC	20,000	1
502354	7	5/8 -11NC	10,000	1



502372

FLANGE NUTS FOR TURBO STYLE BACK-UP PADS

- To be used with JET turbo back-up pads

PROD. NO.	Description	Nut Size	Use with Pad Product No.	Pkg. Qty.
502372	Flange nut	5/8 -11NC	502352 & 502353	1
502373	Flange nut	5/8 -11NC	502354	1



SURFACE CONDITIONING



POWERBLEND® SCD

Flap Disc Surface Conditioning

Super High Performance (for Angle Grinders)

- POWERBLEND® SCD flap discs are made from non-woven abrasive materials that are designed to prepare, clean and polish without altering the dimensions of the workpiece
- Used for rust, scale and paint removal as well as preparation, and finishing of weld seams
- Ideal for use on steel, stainless steel, aluminum, titanium, alloys, fiberglass, plastic and glass
- Can be used in many of industries including: manufacturers of restaurant equipment, aerospace, shipbuilding, propellers, steel and stainless steel furniture, automotive finishing and many more

POWERBLEND®



BEST**

503515



TYPE 29

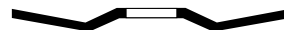

PROD. NO.	Size (inches)	Grit	Max. RPM	Pkg. Qty.
503513	4-1/2 x 7/8	Coarse	13,300	10
503515	4-1/2 x 7/8	Medium	13,300	10
503517	4-1/2 x 7/8	Fine	13,300	10
503523	5 x 7/8	Coarse	12,200	10
503525	5 x 7/8	Medium	12,200	10
503527	5 x 7/8	Fine	12,200	10



PROD. NO.		Pkg. Qty.
503513A01	Same as 503513 in a clamshell package	1
503515A01	Same as 503515 in a clamshell package	1
503517A01	Same as 503517 in a clamshell package	1
503523A01	Same as 503523 in a clamshell package	1
503525A01	Same as 503525 in a clamshell package	1
503527A01	Same as 503527 in a clamshell package	1



Medium

Fine

Coarse

ABRASIVE HAND PADS

High Performance

- Made from non-woven abrasive materials that are ideal for sanding, deburring, cleaning and polishing on steel, stainless steel and aluminum surfaces
- Removes rust corrosion, oxidation and discoloration on all types of metal without clogging
- Cleans paint spatter and overspray, removes fine burrs on metal, cleans whitewall tires and polishes circuit board



PROD. NO.	Size (inches)	Grit	Finish	Pkg. Qty.	Case Qty.
599001	6 x 9		Extra Cut	10	100
599002	6 x 9	80A	Medium	10	100
599004	6 x 9	320A	Very Fine	10	100
599006	6 x 9	600C	Ultra Fine	10	100
599008	6 x 9	Non-Abrasive	Super Fine	10	100

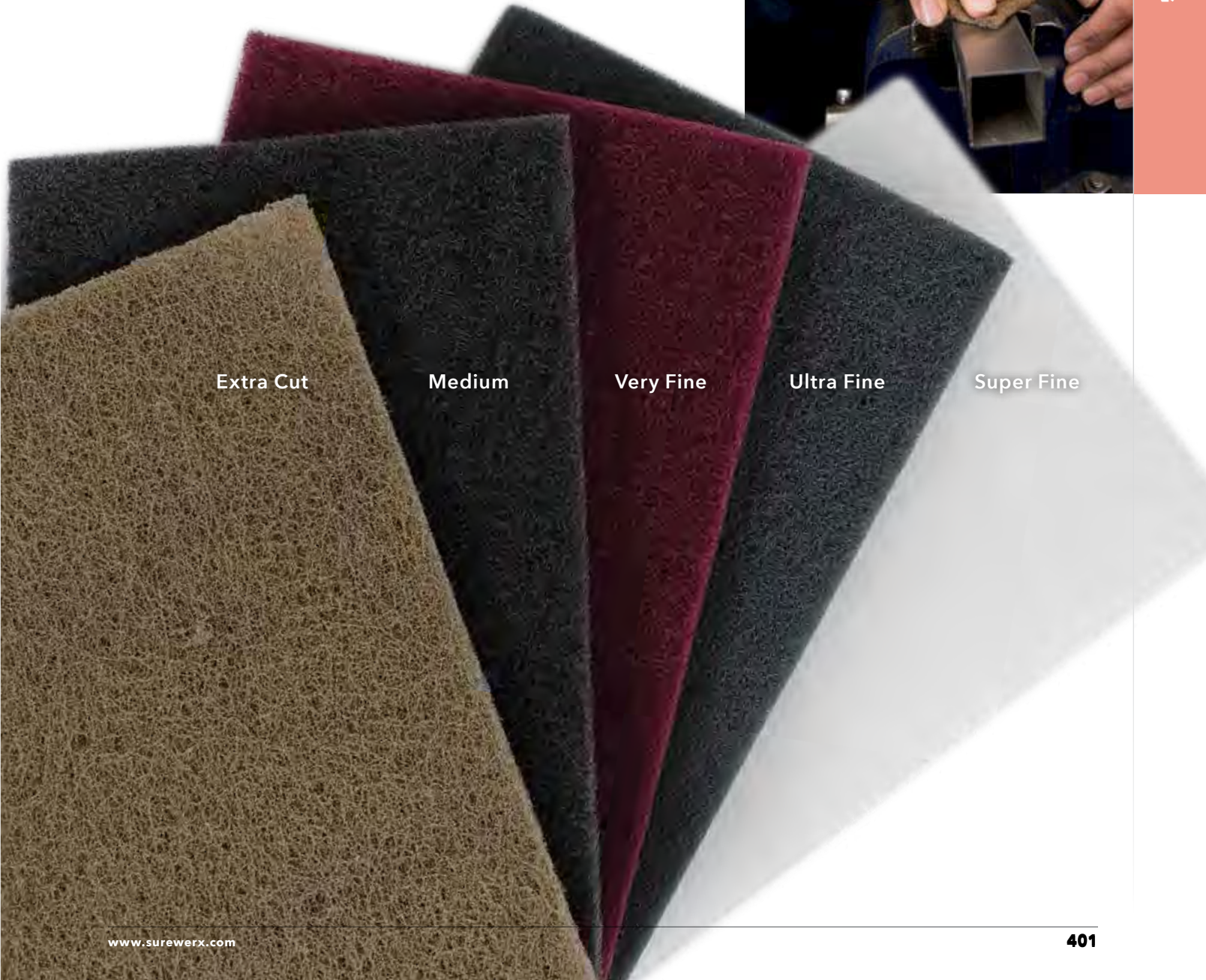
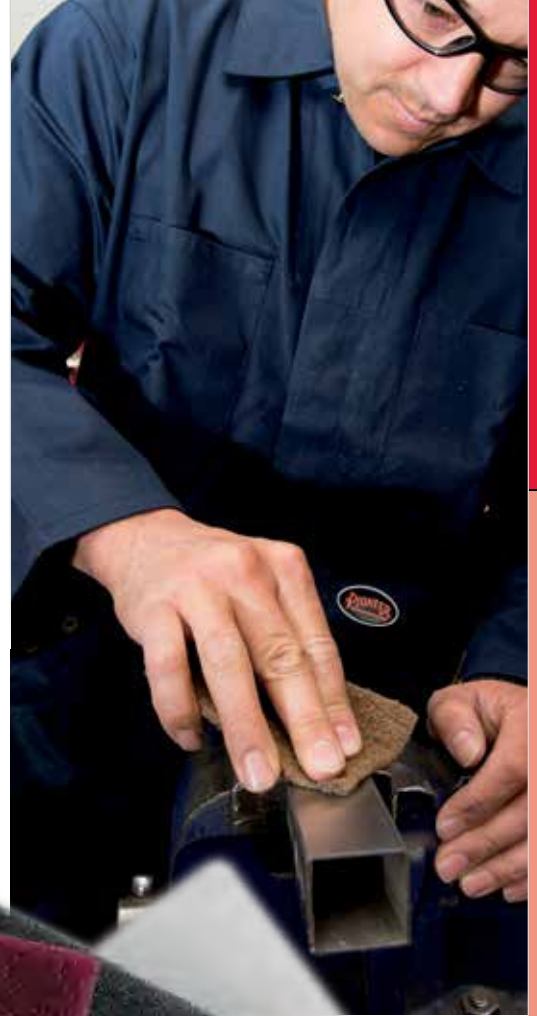

Extra Cut

Medium

Very Fine

Ultra Fine

Super Fine



POWERSTRIP™



503605



503624



503684

POWERSTRIP®

Stripping Discs - High Performance (for Bench Grinders & Drills)

- POWERSTRIP® products are made from superior quality, high-density, non-woven synthetic webbing impregnated with premium abrasive grains for fast effective material removal
- Designed for use in industrial, automotive, marine and fabrication applications for removal of rust, paint, surface coatings, scale, gaskets, weld cleaning, weld spatter, large surface areas and roughens surfaces such as fiberglass
- Suitable for work on almost all metal surfaces including steel, stainless steel, aluminum, wood and many other surfaces
- The non-woven design helps eliminate material from loading on the wheel



TYPE 1

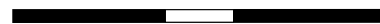

PROD. NO.	Size (inches)	Max. RPM	Recommended RPM	Pkg. Qty.
503605	4 x 1/2 x 1/2	6,000	3,800	10
503609	6 x 1/2 x 1/2	4,000	2,600	10

See next page for **503689** 1/4" mandrel

POWERSTRIP®

Stripping Discs - High Performance (for Angle Grinders)



TYPE 27

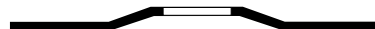

PROD. NO.	Size (inches)	Max. RPM	Recommended RPM	Pkg. Qty.
503624	4-1/2 x 1/2 x 7/8	11,000	7,000	10
503634	5 x 1/2 x 7/8	10,500	6,500	10
503654	7 x 1/2 x 7/8	6,600	5,000	10

POWERSTRIP®

Stripping Discs - High Performance (for Die Grinders)



1/4" SPINDLE

PROD. NO.	Size (inches)	Max. RPM	Recommended RPM	Pkg. Qty.
503682	2 x 1	11,000	4,000	10
503684	3 x 1	7,500	3,500	10

POWERSTRIP®

Roll-On Surface Conditioning Discs
High Performance Type R (for Die Grinders)



PROD. NO.	Size (inches)	Max. RPM	Recommended RPM	Pkg. Qty.
503692	2	11,000	6,000	10
503694	3	7,500	4,500	10

1/4" MANDREL (For 1/2" Arbor Hole Straight Wheels)

PROD. NO.	Description
503689	1/2" x 1/4" Shaft Universal Spindle Arbor for Straight Wheels POWERSTRIP®

SURFACE CONDITIONING DISCS Roll-On - High Performance (for Die Grinders)

- Provides excellent finishing without gouging the base material or altering the original material dimensions
- The aluminum oxide coated nylon fibre pad resists material loading and delivers a consistently smooth uniform finish
- Ideal for surface preparation, rust removal, deburring, paint removal, blending and finishing of steel, stainless steel, alloy steel, aluminum and fiberglass
- Type R mounting system to be used with 502332 and 502333 backing pads



ROLL ON

PROD. NO.	Size (inches)	Grit	Max. RPM	Pkg. Qty.
502255	2	Very Fine	30,000	50
502257	2	Medium	30,000	50
502259	2	Coarse	30,000	50
502260	3	Very Fine	20,000	25
502262	3	Medium	20,000	25
502264	3	Coarse	20,000	25

SEE PAGE 391 FOR
CORRESPONDING
BACKUP PADS



503692



503689



502262





502275 - 502279



502343



SURFACE CONDITIONING DISCS

Scrim Back Discs - High Performance (for Angle Grinders)

- Scrim back surface conditioning discs are extremely popular for surface preparation work
- Provides excellent surface conditioning without gouging the base material or changing the original material dimensions
- The aluminum oxide coated non-woven nylon pads resist loading and delivers a consistently smooth uniform finish
- Ideal for surface preparation, rust removal, deburring, paint removal, blending and finishing of steel, stainless steel, alloy steel, aluminum and wood



PROD. NO.	Size (inches)	Grit	Max. RPM	Type	Pkg. Qty.
502275	5	Very Fine	10,000	Hook & Loop	10
502277	5	Medium	10,000	Hook & Loop	10
502279	5	Coarse	10,000	Hook & Loop	10
502285	7	Very Fine	8,500	Hook & Loop	10
502287	7	Medium	8,500	Hook & Loop	10
502289	7	Coarse	8,500	Hook & Loop	10

GRIPPER BACK-UP PADS

(for Angle Grinders)

- For use with hook and loop surface conditioning products
- 5/8-11NC thread for use on angle grinders and sanders



Hook & loop

PROD. NO.	Diameter and Thread Size (inches)	Max. RPM	Pkg. Qty.
502343	5 - 5/8-11NC	12,000	1
502345	7 - 5/8-11NC	8,500	1

BRUSHING





CRIMPED WIRE WHEEL BRUSHES

High Performance (for Bench Grinders)

- JET's high performance crimped wire wheel brushes have set the standard in Canada as the best performing bench wire wheels for metal applications
- Heavy wire fill and the highest grade piano wire (tempered high carbon steel, wire) have earned JET brushes an enviable reputation for consistent quality and life
- Ideal for general purpose cleanup, paint and rust removal, and light deburring on flat and curved surfaces
- All 6", 7" and 8" wire wheels come with a 2" arbor hole bushed from 1/2" to 5/8" sizes to fit all brands of bench grinders
- Please specify arbor size on 10" and 12" brushes



BETTER**

550125

PROD. NO.	MOD. NO.	Diameter (Inches)	Min Face Width (Inches)	Centre Hole (Inches)	Wire Diameter (Inches)	Type	Max. RPM
550121	101F-2M	6	7/8	12 - 5/8 - 2	.014	Medium	6,000
550123	101F-2F	6	7/8	1/2 - 5/8 - 2	.007	Fine	6,000
550124	101F-3C	6	1	1/2 - 5/8 - 2	.020	Coarse	6,000
550125	101F-3M	6	1	1/2 - 5/8 - 2	.014	Medium	6,000
550131	101C-2M	7	7/8	1/2 - 5/8 - 2	.014	Medium	6,000
550133	101C-3M	7	1-1/4	1/2 - 5/8 - 2	.014	Medium	6,000
550141	101G-2C	8	7/8	1/2 - 5/8 - 2	.020	Coarse	4,500
550142	101G-2M	8	7/8	1/2 - 5/8 - 2	.014	Medium	4,500
550143	101G-2F	8	7/8	1/2 - 5/8 - 2	.007	Fine	4,500
550145	101G-3M	8	1-1/4	1/2 - 5/8 - 2	.014	Medium	4,500
550151	101H-3C	10	1-1/2	2	.020	Coarse	3,600
550152	101H-3M	10	1-1/2	2	.014	Medium	3,600
550154	101H-4M	10	1-3/4	2	.014	Medium	3,600
550165	101K-5C	12	2	2	.020	Coarse	3,000
550166	101K-5M	12	2	2	.014	Medium	3,000

* See next page for adapter plates



GOOD**

554434

CRIMPED WIRE WHEEL BRUSHES

General Purpose (for Bench Grinders)

- Features high tensile strength steel wire for increased life and performance
- Most commonly used to remove paint, rust, and corrosion, light deburring and other cleaning jobs
- Each JET wire wheel is shipped with an adaptor set which allows the wheel to be mounted on all popular bench grinders (1/2, 5/8, 3/4, 1 and 1-1/2")



PROD. NO.	MOD. NO.	Diameter (Inches)	Minimum Face Width (Inches)	Centre Hole (Inches)	Wire Diameter (Inches)	Type	Max. RPM
554434	W614	6	1	1/2 - 1	.014	Medium	6,500
554455	W814	8	1	1/2 - 1	.014	Medium	4,500

2" DIAMETER ADAPTER PLATES



- For 10" and 12" JET bench wire wheels

PROD. NO.	Inside Diameter (inches)	Outside Diameter (inches)
552112	1/2	2
552113	5/8	2
552114	3/4	2
552115	7/8	2
552116	1	2
552118	1-1/4	2
552119	1-1/2	2



552112

HAND SCRATCH BRUSHES

- JET's extensive line of hand scratch brush includes straight back, long and shoe handle, and mini handle brushes in both steel or stainless steel to perform most jobs
- Brushes are made from kiln-dried hardwood for maximum wire tuft retention
- Ideal for removal of rust, paint, scale, weld slag and most other cleaning jobs



PROD. NO.	MOD. NO.	Wire Rows	Type	Wire Type	Overall Length (Inches)	Brush Length (Inches)	Brush Width (Inches)	Wire Length (Inches)
551101	3LH	3 x 19	Long Handle	Carbon Steel	13-3/4	6	15/16	1-1/8
551102	4LH	4 x 19	Long Handle	Carbon Steel	13-3/4	5-1/2	1-1/16	1-1/8
551104	4SH	4 x 16	Shoe Handle	Carbon Steel	10	5-1/2	15/16	1-1/8
551105	4SHSS	4 x 16	Shoe Handle	Stainless Steel	10	5-1/2	1-1/16	1-1/8
551109	4SHWSC	4 x 16	Shoe Handle	Carbon Steel	10	5-1/2	1-1/16	1-1/8
551111	3LHSS	3 x 19	Long Handle	Stainless Steel	13-3/4	6	15/16	1-1/8
551112	4LHSS	4 x 19	Long Handle	Stainless Steel	13-3/4	6	15/16	1-1/8
551117	3MHSS	3 x 7	Mini	Stainless Steel	7-3/4	1-1/2	7/16	7/16
551120	6SB	6 x 19	Straight Back	Carbon Steel	7-1/4	6-3/4	2-1/4	1-5/8



551101



551105



551112



551102



551109



551117



551104



551111



551220



MAXI-CRIMP CUP BRUSHES

Super High Performance (for Angle Grinders)

- Made from a unique crimped cable construction and premium brass coated piano wire (tempered high carbon steel) for increased life and durability
- The cable crimped construction, bundles the individual wires together reducing wire fatigue and wire breakage; thus increasing brush life by up to 50% longer than standard crimped brushes
- Reduced wire breakage results in improved operator safety
- JET MAXI-CRIMP brush retains the flexibility of a standard crimped brush allowing it to conform to irregular surfaces for increased brushing versatility and extended life
- Model **553505** (MC311T) has a rolled lip on the cup for extra strength further reducing wire fatigue
- Models **553507** (MC411T) and **553509** (MC511T) feature ergonomic cups for easier mounting and removal
- Unique mounting feature: multi-fitting thread allows mounting on either a 5/8-11NC or 14mm x 2 spindle



BEST

553505



PROD. NO.	MOD. NO.	O.D. (Inches)	Arbor Hole (Inches)	Wire Diameter (Inches)	Max. RPM	Pkg. Qty.
*553505	MC311T	3	5/8-11NC / 14mm x 2	.023	13,000	1
553507	MC411T	4	5/8-11NC / 14mm x 2	.023	8,500	1
553509	MC511T	5	5/8-11NC / 14mm x 2	.023	8,500	1

* Incredible performance and life – for use on 5" and 6" angle grinders

Multi-fit thread, one brush fits both 5/8-11NC and 14mm x 2 tool spindles





CRIMPED CUP BRUSHES

High Performance (for Angle Grinders)

- JET crimped wire cup brushes are made with quality piano wire (tempered high carbon steel) for fast brushing action and maximum life
 - Designed for surface cleaning, rust and paint removal, and light deburring on large flat surfaces
 - Also ideal for cleaning hardened concrete on forms
 - Crimped wire brushes offer more flexibility and less aggressive brushing than knot brushes where a smoother finish is required
 - All cup brushes are equipped with threaded arbors for fast and easy mounting
- * **553518** is made from stainless steel piano wire to eliminate contamination of the workpiece



PROD. NO.	MOD. NO.	O.D. (Inches)	Arbor Hole (Inches)	Wire Diameter (Inches)	Max. RPM	Pkg. Qty.
554100	CC318T	3	5/8-11NC	.014	14,000	1
554102	CC311-M14	3-1/4	14mm x 2.0	.014	11,500	1
554103	CC311-M10	3-1/4	10mm x 1.25	.014	11,500	1
554105	CC311T	3-1/4	5/8-11NC	.014	11,500	1
*554107	CC3511T	3-1/2	5/8-11NC	.014	11,500	1
*554106	CC3820T	3-3/4	5/8-11NC	.020	9,500	1
553501	CC420T	4	5/8-11NC	.020	8,500	1
553502	CC520T	5	5/8-11NC	.020	8,500	1

* **554107** maximizes your brushing power with JET's exclusive 3-1/2" crimped cup brush - Canada's ultra-performance brush for 5" - 6" angle grinders. The **554106** is exclusive for 6" grinders and the 3-3/4" face width and .020 wire diameter are designed for maximum productivity and performance



PROD. NO.	MOD. NO.	O.D. (Inches)	Arbor Hole (Inches)	Wire Diameter (Inches)	Max. RPM	Pkg. Qty.
*553518	CC311-SST	3	5/8-11NC	.011	12,000	1



553505



553518





BETTER**

554203



BETTER**

554207



BETTER**

553683

KNOT TWISTED CUP BRUSHES

High Performance (for Angle Grinders)

- JET knot twisted wire cup brushes offer a more aggressive cutting action than crimped brushes due to the impact action of the knots and the stiffer wire
 - Used on angle grinders for heavy duty cleaning, weld and scale removal, deburring and general heavy duty brush work
 - Made with high strength carbon steel piano wire for long life when used for heavy duty brushing applications
- * **554207**: Exclusive larger diameter knot twisted brush for 5" and 6" grinders, for improved productivity and performance
- * **553683**: Made from high tensile stainless steel piano wire for contamination free brushing of stainless steel



PROD. NO.	MOD. NO.	Diameter (Inches)	Arbor Hole (Inches)	Wire Diameter (Inches)	Max. RPM
554201	CK3201-M10	3	10mm x 1.25	.020	12,500
554202	CK3201-M14	3	14mm x 2.0	.020	12,500
554203	CK3201-T	3	5/8 - 11NC	.020	12,500
*554207	CK3501-T	3-1/2	5/8 - 11NC	.020	11,500

Exclusive large diameter brush for 5" and 6" grinders improves productivity and performance



PROD. NO.	MOD. NO.	Diameter (Inches)	Arbor Hole (Inches)	Wire Diameter (Inches)	Max. RPM
*553683	CK3201-SST	3	5/8 - 11NC	.020	12,500



KNOT BANDED CUP BRUSHES

High Performance (for Angle Grinders)

- JET knot banded wire cup brushes are similar to a regular knot style cup brush however, have the added feature of a band or knock-off ring. This ring helps to eliminate brush flare out, keeping brush tips in contact with the workpiece for a more aggressive brushing action
 - As the exposed brush wears down to the ring, it is easily knocked off to expose the balance of the wire for increased brush life
 - An excellent safety and performance aid, the band helps to reduce wire breakage caused by flare out
- * **553607** and **553606** feature exclusive larger diameter high density knot twisted brushes for 5" and 6" grinders - the industry's most productive brushes for this grinder range



PROD. NO.	MOD. NO.	Diameter (Inches)	Arbor Hole (Inches)	Wire Diameter (Inches)	Max. RPM
553605	CKB2201T	2-3/4	5/8 - 11NC	.020	12,500
*553607	CKB3001T	3	5/8 - 11NC	.020	11,000
*553606	CKB3201T	3-1/2	5/8 - 11NC	.020	11,000
553652	CKB4201-T	4	5/8 - 11NC	.020	8,500
553655	CKB5201-T	5	5/8 - 11NC	.020	6,500



2-3/4"

553605



3-1/2"

Exclusive large-diameter brush for 5" and 6" grinders improves productivity and performance

553606



Watch the video!
yourproclub.com

Banded ring helps eliminate brush flare out significantly reducing wire breakage

Made with high strength carbon steel piano wire specifically for steel applications



553606

Once exposed brush wears down, the band is easily knocked off to expose the balance of the brush

553606 & 553607 larger diameter brushes are specifically designed to increase productivity for 5" & 6" grinders



BETTER**

554115

CRIMPED CONICAL (BEVEL) BRUSHES

High Performance (for Angle Grinders)

- High speed crimped conical brushes are ideal for removing surface materials such as rust and paint in hard-to-reach corners and inside angles where cup brushes will not fit
- The conical (beveled) shape provides a more flexible brushing action which reduces wire fatigue for improved operator safety and service life
- Heavy duty industrial piano wire ensures long life, superior productivity and increased safety



PROD. NO.	MOD. NO.	O.D. (Inches)	Arbor Hole (Inches)	Wire Diameter (Inches)	Max. RPM	Pkg. Qty.
554115	BC4514T	4-1/2	5/8-11NC	.014	12,500	1
554121	BC514T	5	5/8-11NC	.014	12,500	1
554126	BC615T	6	5/8-11NC	.014	6,000	1



BETTER**

554311

KNOT TWISTED CONICAL (BEVEL) BRUSHES

High Performance (for Angle Grinders)

- High speed knotted conical brushes are ideal for heavy clean-up of weld spatter, slag, rust paint and scale in hard-to-reach areas
- Ideal for cleaning fillet welds, corners and other hard-to-reach areas
- Heavy duty industrial piano wire ensures long life, superior productivity and increased safety



PROD. NO.	MOD. NO.	O.D. (Inches)	Arbor Hole (Inches)	Wire Diameter (Inches)	Max. RPM	Pkg. Qty.
554305	BK420T	4	5/8-11NC	.020	15,000	1
554309	BK4520T	4-1/2	5/8-11NC	.020	12,500	1
554311	BK520T	5	5/8-11NC	.020	11,000	1
554316	BK620T	6	5/8-11NC	.020	9,000	1



STRINGER BEAD BRUSHES

High Performance (for Angle Grinders)



- These general purpose brushes are designed to offer great performance at an outstanding price
- Specifically designed for root and hot pass weld cleaning in pipe joining applications
- Stringer bead brushes can also be used wherever a controlled, aggressive brushing action is required on confined surface contact areas
- These brushes are made with high quality carbon steel wire for long life
- Ideal for a variety of general automotive and industrial jobs



PROD. NO.	MOD. NO.	Diameter (Inches)	Thread Size (Inches)	Face Width (Inches)	Wire Diameter (Inches)	Max. RPM	Pkg. Qty.
553434	4SB120-TP	4	5/8-11NC	1/4	.020	20,000	1
553436	45SB120-TP	4-1/2	5/8-11NC	1/4	.020	15,000	1
553452	5SB120-TP	5	5/8-11NC	1/4	.020	15,000	1



553436



STRINGER BEAD BRUSHES

Super High Performance (for Angle Grinders)

- These super high performance brushes are made from top quality USA high carbon steel wire for optimum life and performance
- Specifically designed for root and hot pass weld cleaning in pipe joining applications
- Stringer bead brushes can also be used wherever a controlled, aggressive brushing action is required on confined surface contact areas
- The superior balance and high knot count of our brush ensures smooth but aggressive brushing action for fast material removal



PROD. NO.	MOD. NO.	Diameter (Inches)	Thread Size (Inches)	Face Width (Inches)	Wire Diameter (Inches)	Max. RPM	Pkg. Qty.
553432	4SB120-T	4	5/8-11NC	1/4	.022	20,000	12
553451	5SB120-T	5	5/8-11NC	1/4	.022	15,000	12
553401	6SB120-T4	6	5/8-11NC	1/4	.022	10,000	12



553451



PROD. NO.	MOD. NO.	Dia. (Inches)	Thread Size (Inches)	Face Width (Inches)	Wire Diameter (Inches)	Max. RPM	Pkg. Qty.
553441	4SB120-SST	4	5/8-11NC	1/4	.022	20,000	12
553462	5SB120-SST	5	5/8-11NC	1/4	.022	15,000	12
553411	6SB120-SST	6	5/8-11NC	1/4	.022	10,000	12



553462





BETTER**

553324



BEST**

553322

FULL CABLE TWIST KNOT WHEELS

High Performance (for Angle Grinders)

- These general purpose brushes are designed to offer great performance at an outstanding price
- Made with high quality carbon steel wire for long life
- Ideal for a variety of general automotive and industrial jobs
- Each brush comes in its own clamshell package for in-store display purposes



PROD. NO.	MOD. NO.	Diameter (inches)	Thread Size (inches)	Face Width (inches)	Wire Diameter (inches)	Max. RPM	Pkg. Qty.
553328	4K123-TP	4	5/8-11NC	1/2	.020	20,000	1
553332	45K123-TP	4-1/2	5/8-11NC	1/2	.020	15,000	1
553324	5K123-TP	5	5/8-11NC	1/2	.020	15,000	1

FULL CABLE TWIST KNOT WHEELS

Super High Performance (for Angle Grinders)

- These super high performance brushes are made from top quality USA high carbon steel wire for maximum performance and life
- Full cable twist brushes are made with tightly wound, low flex tufts which offer a very aggressive high impact brushing action with best control at the surface contact area
- The best brush for weld cleaning, weld spatter and scale removal, cleaning, deburring and flash removal where surface finish is a low priority
- Also used in pipe joining for cleaning scale and spatter following welding



PROD. NO.	MOD. NO.	Diameter (inches)	Thread Size (inches)	Face Width (inches)	Wire Diameter (inches)	Max. RPM	Pkg. Qty.
553327	4K123-T	4	5/8-11NC	1/2	.022	20,000	12
553322	5K123-T	5	5/8-11NC	1/2	.022	15,000	12
553302	6K123-T	6	5/8-11NC	1/2	.022	10,000	12

CRIMPED WIRE WHEEL BRUSHES

High Performance (for Angle Grinders)

- Designed to offer great performance at an outstanding price
- Made with premium .014 (medium) carbon steel wire
- Ideal for a variety of general industrial and automotive applications
- Less aggressive than knot and stringer bead brushes, where a smoother finish is required



PROD. NO.	MOD. NO.	Diameter (inches)	Arbor Hole (inches)	Wire Size (inches)	Max. RPM	Pkg. Qty.
553015	45C14T	4-1/2	5/8-11NC	.014	12,500	1
553025	5C14T	5	5/8-11NC	.014	12,000	1



553025



BIGGER, BETTER, *FASTER* FOR 5" AND 6" GRINDERS

JET's extensive line of wire brushes for 5" and 6" grinders are specifically designed and built to run safely at higher RPMs. This enables users to mount larger diameter brushes on 5" or 6" grinders for increased productivity and performance without compromise to operator safety.



Max. RPM 14,000
554100

For 6" Grinders Only



Max. RPM 9,500
554106



Max. RPM 11,500
554105



Max. RPM 11,500
554107



Max. RPM 12,500
554203



Max. RPM 11,500
554207



Max. RPM 12,000
553025



Max. RPM 12,500
554121



Max. RPM 12,500
553605



Max. RPM 11,000
553607



Max. RPM 11,000
553606



Max. RPM 11,000
554311

DESIGNED TO RUN SAFELY AT HIGHER RPM'S



BEST

550310

FULL CABLE TWIST KNOT WHEELS UNTHREADED

Super High Performance

(for Die Grinders, End Grinders and Bench Grinders)

- These high performance brushes are made from top quality USA high carbon steel wire for maximum performance and life
- Full cable twist brushes are made with tightly wound, low flex tufts which offer a very aggressive high impact brushing action with best control at the surface contact area
- The best brush for weld cleaning, weld spatter and scale removal, cleaning, deburring and flash removal where surface finish is a low priority
- Also used in pipe joining for cleaning scale and spatter following welding
- Available in high quality carbon steel
- 6" and 8" brushes come with round centre holes for use on end grinders and bench grinders - 3-1/4" brush is popular in the automotive trades for use on die grinders

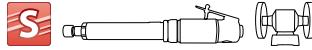

PROD. NO.	MOD. NO.	Diameter (Inches)	Thread Size (Inches)	Face Width (Inches)	Wire Diameter (Inches)	Max. RPM	Pkg. Qty.
550310	3K114	3-1/4	3/8 - 1/2	1/2	.014	25,000	1
550303	6K120	6	5/8 - 1/2	1/2	.020	9,000	1
550306	8K120	8	5/8 - 1/2	1/2	.020	8,500	1



550802 - Cup



553701 - End

KNOT TWISTED END BRUSHES

High Performance 1/4" Shaft (for Drills and Die Grinders)

- Mounted on 1/4" shafts, these brushes are suitable for use on drills and/or die grinders
- Always ensure that the RPM rating of the tool used is not greater than the RPM rating of the brush used
- Ideal for heavy duty jobs such as heavy bur and scale removal, cleaning rust, castings and paint around studs and bolts
- Knot twisted brushes are available in end, cup and radial styles

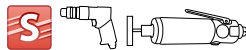

**
BETTER

553792 - Radial

PROD. NO.	MOD. NO.	Diameter (Inches)	Type	Wire Diameter (Inches)	Max. RPM
550802	8046	1-1/8	Knot Cup	.020	6,000
553701	EK1-200	2-3/8	Knot End	.020	20,000
553742	EKR275-20	3	Knot Radial	.020	25,000

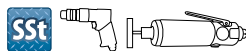

PROD. NO.	MOD. NO.	Diameter (Inches)	Type	Wire Diameter (Inches)	Max. RPM
553792	EKR275-20SS	3	Knot Radial	.020	25,000

CRIMPED END BRUSHES

High Performance 1/4" Shaft (for Drills and Die Grinders)

- Made from high quality crimped wire for increased life and performance
- Mounted on 1/4" shafts, these brushes are suitable for use on drills and/or die grinders
- Ideal for general surface cleaning rust, scale and paint removal
- Excellent for cleaning valve seats in cylinder blocks and carbon deposits

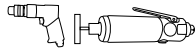

CRIMPED END

PROD. NO.	MOD. NO.	Diameter (Inches)	Type	Wire Diameter (Inches)	Max. RPM
553712	E050-12	1/2	Crimped End	.012	25,000
553713	E050-20	1/2	Crimped End	.020	25,000
553714	E075-12	3/4	Crimped End	.012	22,000
553716	E100-12	1	Crimped End	.012	20,000

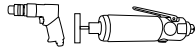

CRIMPED CUP

PROD. NO.	MOD. NO.	Diameter (Inches)	Type	Wire Diameter (Inches)	Max. RPM
550701	114M	2	Crimped Cup	.008	6,500 *
553722	EC175-12	2-1/2	Crimped Cup	.012	13,000
550702	114	3	Crimped Cup	.008	6,500 *

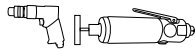

CRIMPED RADIAL

PROD. NO.	MOD. NO.	Diameter (Inches)	Type	Wire Diameter (Inches)	Max. RPM
550905	126	1-1/2	Crimped Radial	.020	25,000
550906	105-2	2	Crimped Radial	.020	25,000
553733	ER200-12	2	Crimped Radial	.012	25,000
553735	ER300-12	3	Crimped Radial	.012	25,000

* Use on drills only



553716 - End



553722 - Cup



553733 - Radial



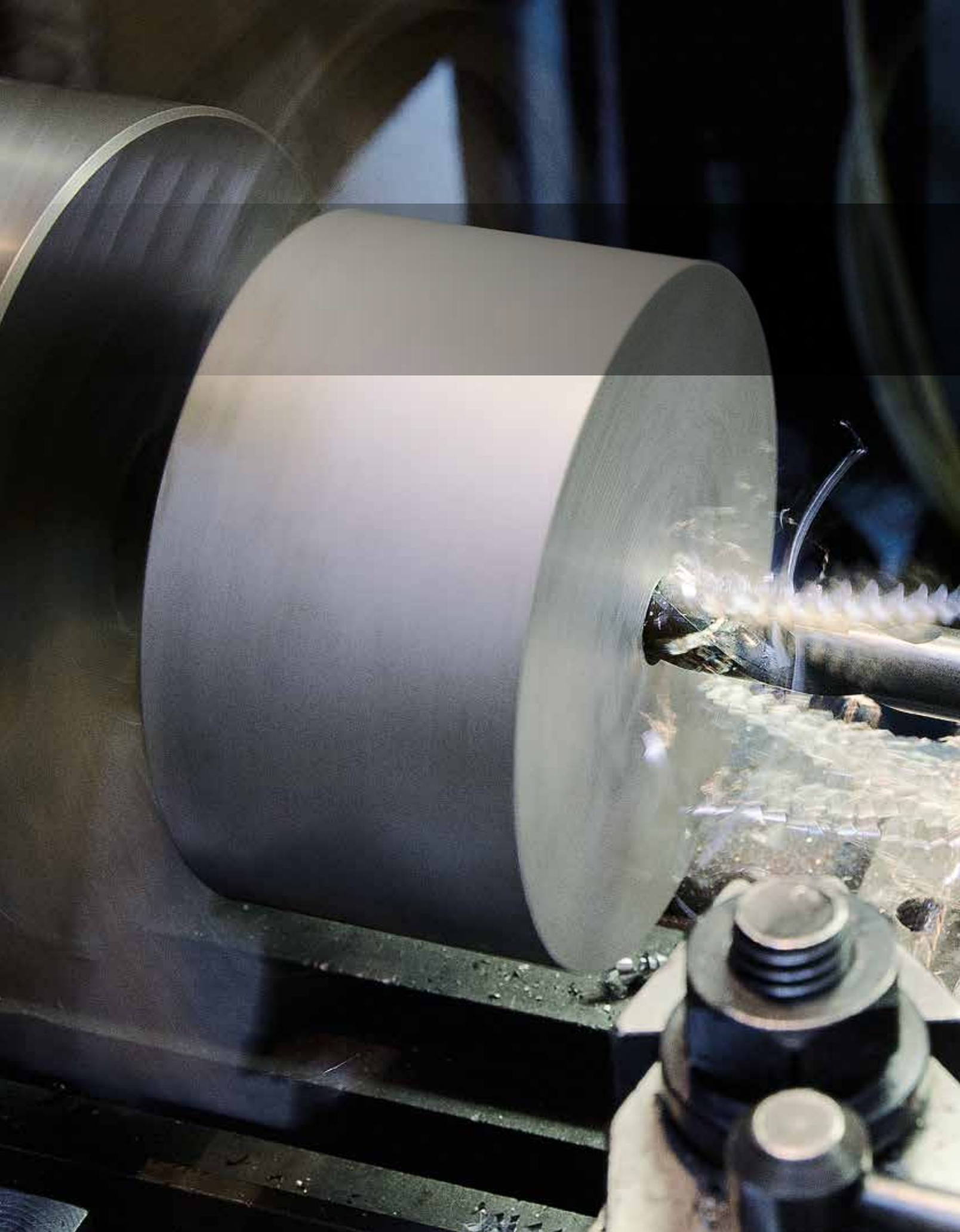

TOOLING

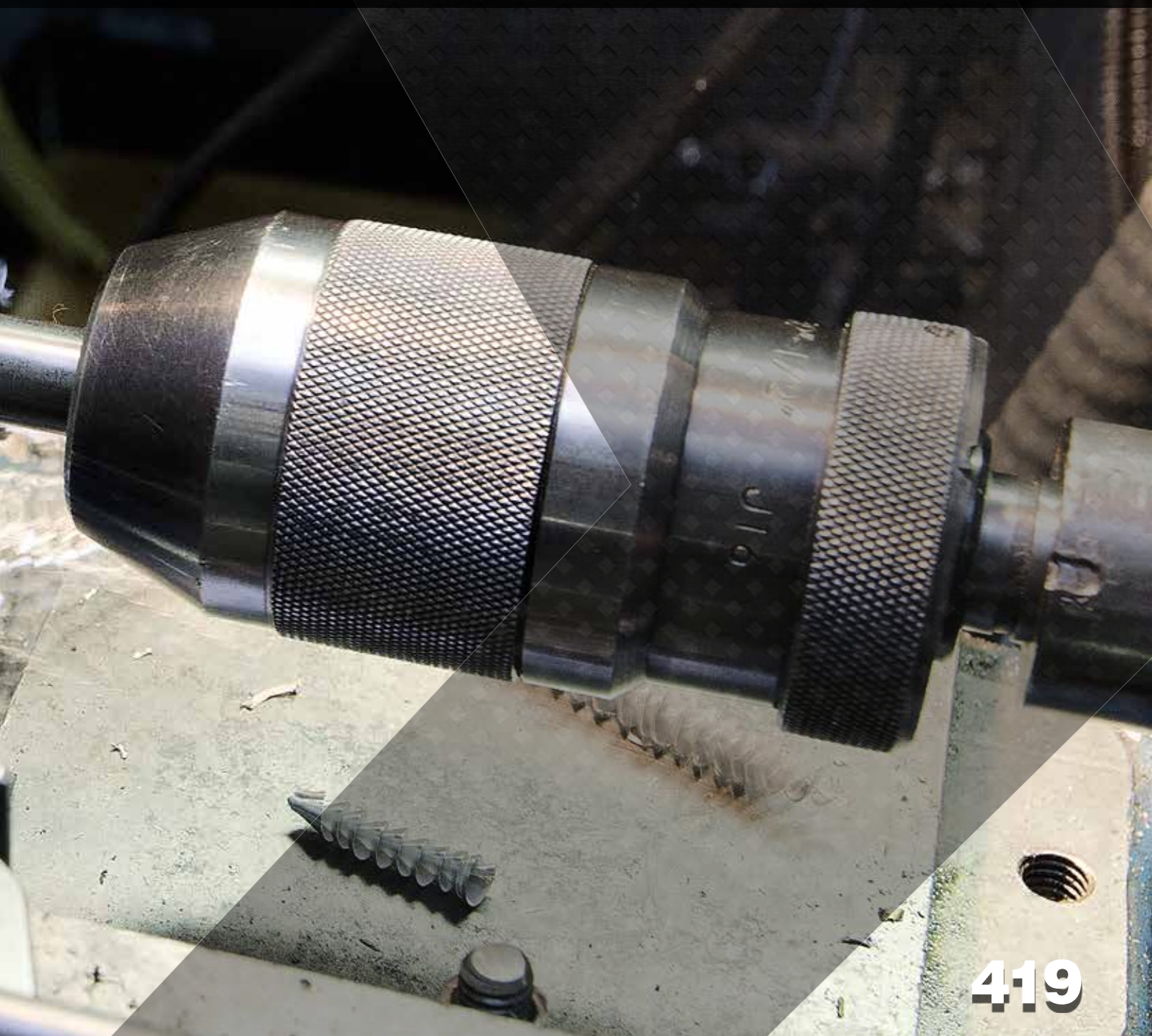

JET-KUT[®]

CARBIDE BURS

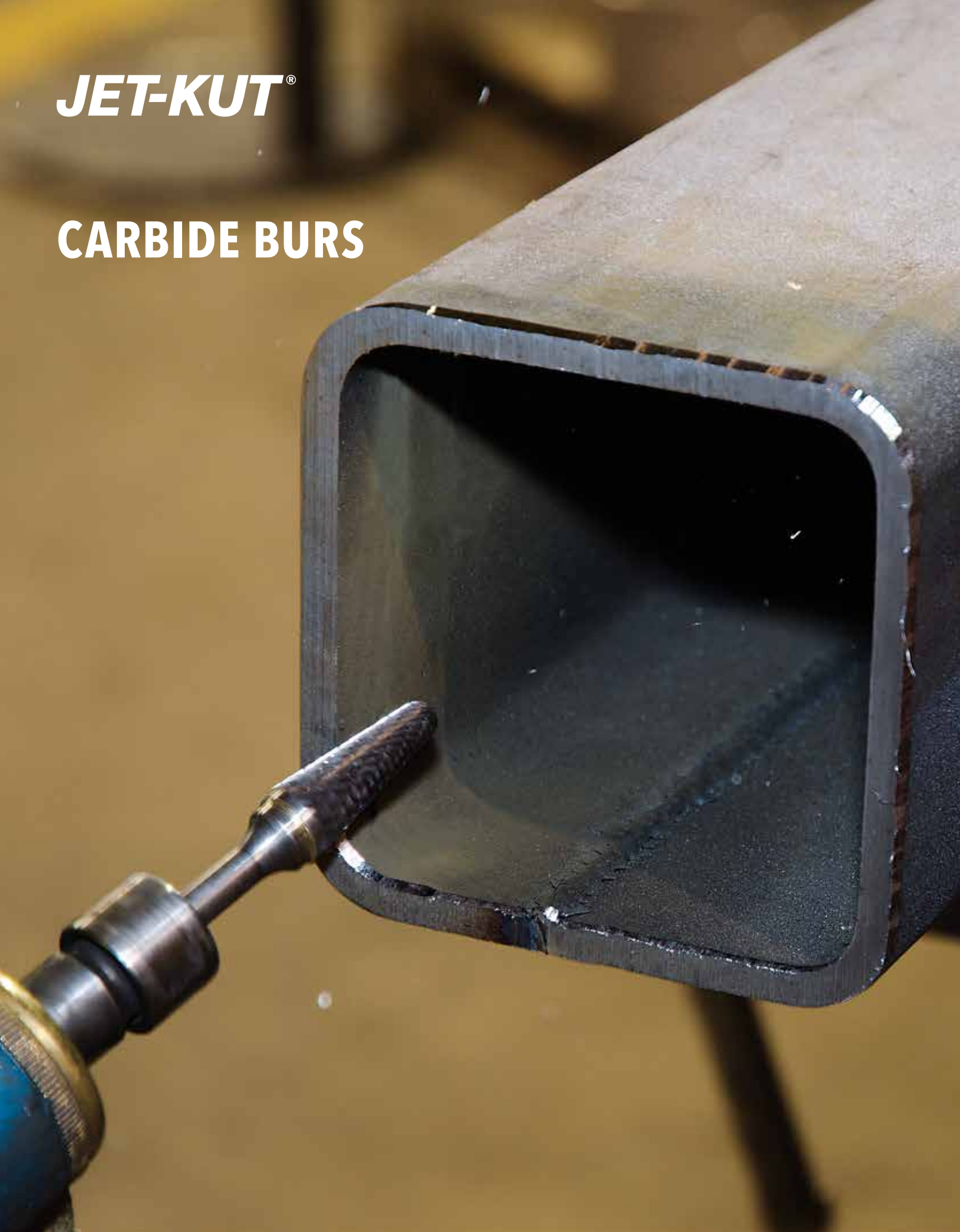

- JET-KUT® Carbide burs are designed to provide excellent cutting performance at an economical cost
- These double cut tungsten carbide burs are designed for shaping, smoothing, and material removal of hardened steel, stainless steel, cast iron, non-ferrous metals, fired ceramics, plastics, and hardwoods, up to material hardness of HRC-65
- Ideal for general shop and jobsite use where price and performance are a priority



JET-KUT®
SUPER PREMIUM CARBIDE BURS



Improved design for faster cutting and longer life.

PROD. NO.	MOD. NO.	Head Shape	Head Diameter (inches)	Head Length (inches)	Angle
534004	A1-DC	A	1/4	5/8	
534008	A3-DC	A	3/8	3/4	
534012	A5-DC	A	1/2	1	
534034	C1-DC	C	1/4	5/8	
534038	C3-DC	C	3/8	3/4	
534042	C5-DC	C	1/2	1	
534049	D1-DC	D	1/4	7/32	
534053	D3-DC	D	3/8	5/16	
534057	D5-DC	D	1/2	7/16	
534068	E3-DC	E	3/8	5/8	
534072	E5-DC	E	1/2	7/8	
534079	F1-DC	F	1/4	5/8	
534083	F3-DC	F	3/8	3/4	
534087	F5-DC	F	1/2	1	
534094	G1-DC	G	1/4	5/8	
534098	G3-DC	G	3/8	3/4	
534102	G5-DC	G	1/2	1	
534155	L2-DC	L	5/16	7/8	14°
534158	L3-DC	L	3/8	1-1/16	14°
534161	L4-DC	L	1/2	1-1/8	14°
534174	M4-DC	M	3/8	5/8	28°
534177	M5-DC	M	1/2	7/8	28°

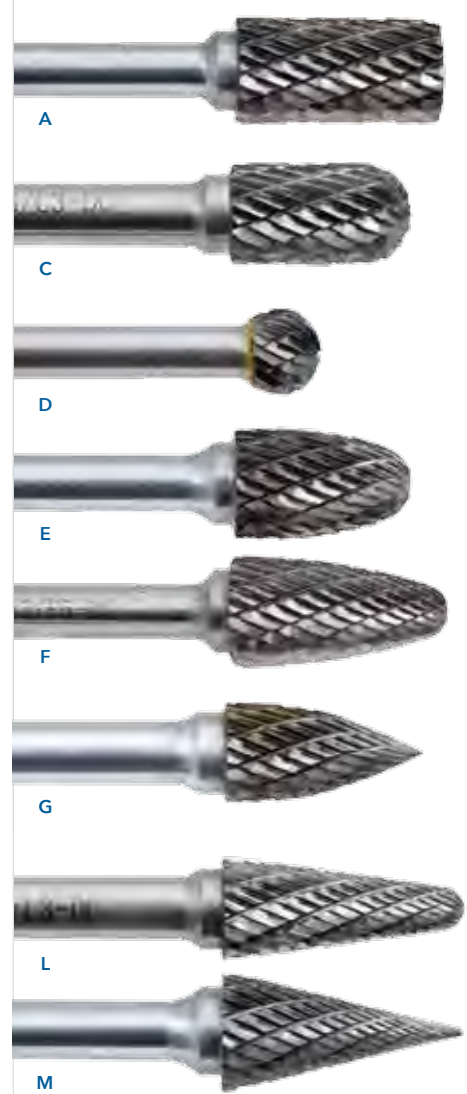

4 PC JET-KUT® Carbide Bur Set 534192 / CBGP-4

- This convenient 4 piece set is ideal for shaping, smoothing, and material removal of hardened steel, stainless steel, cast iron, and non-ferrous metals
- Set includes: **534008, 534038, 534087, 534158**





JET-KUT®
SUPER PREMIUM CARBIDE BURS

BEST



A. Cylinder



B. Cylinder with end cut

B. Shape
- end cut view



C. Cylinder with radius end



D. Ball



E. Oval



F. Tree with radius end



G. Tree with pointed end



K. Cone 90°



L. Taper with radius end



M. Cone



N. Inverted cone

JET-KUT®
Carbide Burs Super Premium Double Cut 1/4" Shank
(for Die Grinders)

- Ideal for high alloy steel and other high quality tool steels, stainless steel and heat resistant castings as well as plastic material, brass and cold forged aluminum
- Made from high grade tungsten carbide for increased life and performance
- High strength brazed joints minimizes vibration and eliminates breakage



PROD. NO.	MOD. NO.	Head Shape	Head Diameter (inches)	Head Length (inches)	Angle
533301	A1-D	A	1/4	5/8	0
533303	A3-D	A	3/8	3/4	0
533305	A5-D	A	1/2	1	0
533306	A6-D	A	5/8	1	0
533311	B1-D	B	1/4	5/8	0
533313	B3-D	B	3/8	3/4	0
533315	B5-D	B	1/2	1	0
533316	B6-D	B	5/8	1	0
533321	C1-D	C	1/4	5/8	0
533323	C3-D	C	3/8	3/4	0
533325	C5-D	C	1/2	1	0
533326	C6-D	C	5/8	1	0
533331	D1-D	D	1/4	7/32	0
533333	D3-D	D	3/8	5/16	0
533335	D5-D	D	1/2	7/16	0
533341	E1-D	E	1/4	3/8	0
533343	E3-D	E	3/8	5/8	0
533345	E5-D	E	1/2	7/8	0
533351	F1-D	F	1/4	5/8	0
533353	F3-D	F	3/8	3/4	0
533355	F5-D	F	1/2	1	0
533361	G1-D	G	1/4	5/8	0
533363	G3-D	G	3/8	3/4	0
533365	G5-D	G	1/2	1	0
533395	K5-D	K	1/2	1/4	90°
533402	L2-D	L	5/16	7/8	14°
533403	L3-D	L	3/8	1-1/16	14°
533404	L4-D	L	1/2	1-1/8	14°
533414	M4-D	M	3/8	5/8	28°
533415	M5-D	M	1/2	7/8	28°
533416	M6-D	M	5/8	1	31°
533422	N2-D	N	3/8	3/8	13°
533423	N3-D	N	1/2	1/2	28°
533425	N5-D	N	5/8	3/4	18°

**Carbide Bur Sets Super Premium Double Cut 1/4" Shank
(for Die Grinders)**

- JET offers an assortment of kits made up of the same high quality burs as offered in open stock
- Available in 8 piece; 16 piece; and 7 piece with die grinder configurations



PROD. NO.	MOD. NO.	Description	Includes
533904	CBK-8	8 PC JET-KUT® Carbide Bur Set In Wooden Box	533305, 533323, 533325, 533335, 533353, 533355, 533363, 533404
533907	CBK-16	16 PC JET-KUT® Carbide Bur Set in Wooden Box	533301, 533303, 533305, 533321, 533323, 533325, 533333, 533335, 533343, 533351, 533353, 533355, 533361, 533363, 533403, 533404
533912	CBK-90	7 PC Grinder/Bur Kit In Plastic Box	533301, 533321, 533331, 533341, 533351, 533361 402109 (.3HP 1/4" Mini Die Grinder)



533904



533907



533912





JET-KUT®
SUPER PREMIUM CARBIDE BURS



A. Cylinder



C. Cylinder with radius end



F. Tree with radius end



L. Taper with radius end

BEST**

Non-ferrous
cut

JET-KUT®

**Carbide Burs - Super Premium Non-Ferrous Single Cut 1/4" Shank
(for Die Grinders)**

- These burs are designed for use on aluminum, non-ferrous metals, soft steel, reinforced plastics and other soft materials
- The exclusive tooth geometry and flute design guarantees maximum cutting performance and chip ejection
- Burs are precisely manufactured to minimize vibration and eliminate breakage

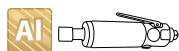

PROD. NO.	MOD. NO.	Head Shape	Head Diameter (inches)	Head Length (inches)	Angle
533605	A5-NF	A	1/2	1	
533625	C5-NF	C	1/2	1	
533655	F5-NF	F	1/2	1	
533704	L4-NF	L	1/2	1-1/8	14°

JET-KUT®

**Long Shaft Carbide Burs - Super Premium Double Cut 1/4" Shank
(for Die Grinders)**

- Ideal for high alloy steel and other high quality tool steels, stainless steel and heat resistant castings as well as plastic material, brass and cold forged aluminum
- Made from high grade tungsten carbide for increased life and performance
- 6" shaft is ideal for work in hard-to-reach places



PROD. NO.	MOD. NO.	Head Shape	Head Diameter (inches)	Head Length (inches)	Shank Length (inches)
534401	A1-DL6	A	1/4	1/2	6
534403	A3-DL6	A	3/8	3/4	6
534405	A5-DL6	A	1/2	1	6
534421	C1-DL6	C	1/4	1/2	6
534423	C3-DL6	C	3/8	3/4	6
534425	C5-DL6	C	1/2	1	6
534451	F1-DL6	F	1/4	1/2	6
534453	F3-DL6	F	3/8	3/4	6
534455	F5-DL6	F	1/2	1	6

BEST**



Extra Long 6" Shaft

JET-KUT[®]

DRILL BITS





JET-KUT®

135° SPLIT POINT DRILL BITS - BLACK OXIDE FINISH



JET-KUT®

Jobber Length Bits 135° Split Point Black Oxide Finish

General Purpose (for Drills and Drill Presses)

- Self-centering 135° split points provide consistent hole sizes and accurate hole placement without a centre punch
- Manufactured from high speed steel to drill faster and last longer
- Fully ground flutes for consistent hole sizes and fast chip evacuation
- Black oxide finish prevents chips from welding to flutes and cutting surfaces, extending cutting tool life
- Top quality bits at low cost, ideal for cordless drills, portable drills and drill presses



PROD. NO.	Size (inches)	Pkg. Qty.	PROD. NO.	Size (inches)	Pkg. Qty.
570204	1/16	12	570219	19/64	6
570205	5/64	12	570220	5/16	6
570206	3/32	12	570221	21/64	6
570207	7/64	12	570222	11/32	6
570208	1/8	12	570223	23/64	6
570209	9/64	12	570224	3/8	6
570210	5/32	12	570225	25/64	6
570211	11/64	12	570226	13/32	6
570212	3/16	12	570227	27/64	6
570213	13/64	12	570228	7/16	6
570214	7/32	12	570229	29/64	6
570215	15/64	12	570230	15/32	6
570216	1/4	12	570231	31/64	6
570217	17/64	12	570232	1/2	6
570218	9/32	12			

29 PC JET-KUT® Drill Bit Set General Purpose (for Drills and Drill Presses)

570108 / 29CD

- Available in popular 29 piece format with strong metal index box to protect and organize your bits
- Self-centering 135° split point provides consistent hole sizes and accurate hole placement without a centre punch
- Manufactured from high speed steel to drill faster and last longer
- 1/16" through 1/2" by 64ths



- Self-centering 135° split point provides consistent hole sizes and accurate hole placement without a centre punch
- Manufactured from high speed steel to drill faster and last longer
- Fully ground flutes for consistent hole sizes and fast chip evacuation
- Black oxide finish prevents chips from welding to flutes and cutting surfaces, extending cutting tool life
- Top quality bits at low cost, ideal for cordless drills, portable drills and drill presses



PROD. NO.	Size (inches)	Shank dia. (inches)	Pkg. Qty.	PROD. NO.	Size (inches)	Shank dia. (inches)	Pkg. Qty.
570533	33/64	1/2	1	570546	23/32	1/2	1
570534	17/32	1/2	1	570547	47/64	1/2	1
570535	35/64	1/2	1	570548	3/4	1/2	1
570536	9/16	1/2	1	570549	49/64	1/2	1
570537	37/64	1/2	1	570550	25/32	1/2	1
570538	19/32	1/2	1	570551	51/64	1/2	1
570539	39/64	1/2	1	570552	13/16	1/2	1
570540	5/8	1/2	1	570556	7/8	1/2	1
570541	41/64	1/2	1	570560	15/16	1/2	1
570542	21/32	1/2	1	570564	1	1/2	1
570543	43/64	1/2	1	570568	1-1/16	1/2	1
570544	11/16	1/2	1	570572	1-1/8	1/2	1
570545	45/64	1/2	1	570580	1-1/4	1/2	1

AIR DRILLS

JET carries a complete range of pneumatic drills to meet the needs of every application. See our Air Tools section for more information.



3/8" Reversible Drill Keyed Chuck - Heavy Duty
404412



3/8" Reversible Drill Keyed Chuck - Standard Duty
404415



3/8" Reversible Drill Keyless Chuck - Heavy Duty
404419



1/2" Reversible Drill Keyed Chuck - Heavy Duty
404422



1/2" Drill - Keyed Chuck Standard Duty
404423



1/2" Reversible Drill Keyless Chuck - Heavy Duty
404424



3/8" Reversible Angle Head Drill - Heavy Duty
404418

JET-KUT®

135° SPLIT POINT DRILL BITS - BLACK OXIDE FINISH



135° split point eliminates "walking", provides fast penetration

Fully ground flutes for closer hole tolerances and better chip ejection

Industrial quality high speed steel





TORQUE DRIVE

JET-KUT® B+G SERIES

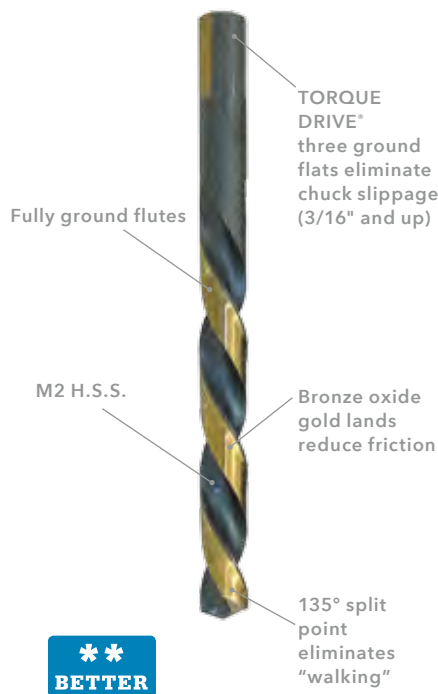

JET-KUT® B&G

Jobber Length Drill Bits M2 135° Split Point Black & Gold Finish Premium (for Drills and Drill Presses)

- Premium 135° split point – black and gold finish
- Professional grade M2 high speed steel bits at competitive prices
- Bronze oxide gold lands to reduce friction for cooler cutting and longer bit life
- Nitro carburized black flutes for improved surface hardness ensure bit stays sharp longer
- 135° split point eliminate “walking”
- TORQUE DRIVE® three ground flats eliminate chuck slippage (available from size 3/16" and larger) - smaller sizes have round shanks



PROD. NO.	Size (inches)	Pkg. Qty.	PROD. NO.	Size (inches)	Pkg. Qty.
570604	1/16	12	570619	19/64	6
570605	5/64	12	570620	5/16	6
570606	3/32	12	570621	21/64	6
570607	7/64	12	570622	11/32	6
570608	1/8	12	570623	23/64	6
570609	9/64	12	570624	3/8	6
570610	5/32	12	570625	25/64	6
570611	11/64	12	570626	13/32	6
570612	3/16	12	570627	27/64	6
570613	13/64	12	570628	7/16	6
570614	7/32	12	570629	29/64	6
570615	15/64	12	570630	15/32	6
570616	1/4	12	570631	31/64	6
570617	17/64	12	570632	1/2	6
570618	9/32	12			



JET-KUT® B&G

Drill Bit Sets Premium (for Drills and Drill Presses)

- Available in popular 29 piece format with a strong metal box to protect and organize your bits
- Premium 135° split point – black and gold finish
- Professional grade M2 high speed steel bits at competitive prices
- Bronze oxide gold lands to reduce friction for cooler cutting and longer bit life
- Nitro carburized black flutes for improved surface hardness ensure bit stays sharp longer
- 135° split point eliminates “walking”
- TORQUE DRIVE® three ground shanks eliminate chuck slippage (available from size 3/16" and larger)



PROD. NO.	MOD. NO.	Package Quantity	Description
570146	BG29	29 pieces	1/16" through 1/2" by 64ths

570147	BG29RS	29 pieces	1/16" through 1/2" by 64ths Sizes 25/64" - 1/2" are 3/8"
--------	--------	-----------	-------------------------------------------------------------

JET-KUT® B&G

Stubby Length Bits M2 135° Split Point Black and Gold Finish Premium (for Drills and Drill Presses)

- Designed for drilling holes in sheet metal, machined parts, aircraft, rivets and confined spaces where a shorter more accurate drill bit is required
- The short length of the drill flute increases the hardness and rigidity for the most precise, accurate drilling
- Premium 135° split point – black and gold finish
- Bronze oxide gold ends to reduce friction for cooler cutting and longer bit life
- 135° split point eliminate “walking”
- TORQUE DRIVE® three ground flats eliminate chuck slippage (available from size 3/16 and larger) smaller sizes have round shanks
- Available from 1/8" to 1/2" in increments of 64ths



PROD. NO.	Size (inches)	Pkg. Qty.	PROD. NO.	Size (inches)	Pkg. Qty.
570658	1/8	12	570671	21/64	6
570659	9/64	12	570672	11/32	6
570660	5/32	12	570673	23/64	6
570661	11/64	12	570674	3/8	6
570662	3/16	12	570675	25/64	6
570663	13/64	12	570676	13/32	6
570664	7/32	12	570677	27/64	6
570665	15/64	12	570678	7/16	6
570666	1/4	12	570679	29/64	6
570667	17/64	12	570680	15/32	6
570668	9/32	12	570681	31/64	6
570669	19/64	6	570682	1/2	6
570670	5/16	6			

TORQUE DRIVE®

JET-KUT® B+G SERIES



BETTER**



BETTER**



TORQUE DRIVE

JET-KUT® B+G SERIES

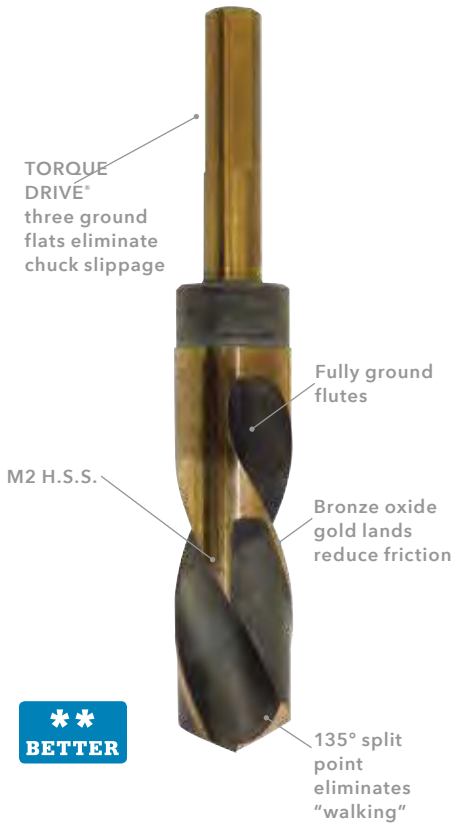

JET-KUT® B&G

Prentice Drill Bits M2 135° Split Point Black and Gold Finish Premium (for Drills and Drill Presses)

- Professional grade M2 high speed steel bits
- Bronze oxide gold ends to reduce friction for cooler cutting and longer bit life
- Nitro carburized black flutes for improved surface hardness ensure bit stays sharp longer
- 135° split point eliminates “walking”
- TORQUE DRIVE® three ground shanks eliminate chuck slippage



PROD. NO.	Size (inches)	Pkg. Qty.	PROD. NO.	Size (inches)	Pkg. Qty.
571234	17/32	1	571248	3/4	1
571236	9/16	1	571252	13/16	1
571240	5/8	1	571256	7/8	1
571242	21/32	1	571260	15/16	1
571244	11/16	1	571264	1	1



JET-KUT® GOLD

Jobber Length Drill Bits M2 135° Split Point Bronze Oxide (Gold) Finish Super Premium (for Drills and Drill Presses)

- JET-KUT® Gold drill bits are the most advanced drill bits available in the Canadian market
- These bits feature razor sharp 135° split point self centering tips, eliminating “walking” and the need for centre punching and penetrate on contact
- The superior bronze oxide (gold) ground flute finish reduces friction, allowing outstanding drilling performance with less operator pressure
- Special flute form enhances chip ejection, reduces drill retractions (woodpeckering) and improves coolant flow to the tip
- Heavy duty, high molybdenum steel offers greater strength and rigidity, longer lasting cutting edges and improved hole tolerances, permitting higher feed rates
- JET offers the TORQUE DRIVE® three flat shank for chuck to bit gripping power that is unparalleled in the industry (available on 3/16" diameter and larger bits)
- Greatly reduces chuck and shank damage and increases cutting efficiency
- Drill up to 4 times faster and last up to 7 times longer than regular drill bits in steel, stainless steel and alloy steel applications



PROD. NO.	Size (inches)	Pkg. Qty.	PROD. NO.	Size (inches)	Pkg. Qty.
570254	1/16	12	570269	19/64	6
570255	5/64	12	570270	5/16	6
570256	3/32	12	570271	21/64	6
570257	7/64	12	570272	11/32	6
570258	1/8	12	570273	23/64	6
570259	9/64	12	570274	3/8	6
570260	5/32	12	570275	25/64	6
570261	11/64	12	570276	13/32	6
570262	3/16	12	570277	27/64	6
570263	13/64	12	570278	7/16	6
570264	7/32	12	570279	29/64	6
570265	15/64	12	570280	15/32	6
570266	1/4	12	570281	31/64	6
570267	17/64	12	570282	1/2	6
570268	9/32	12			

JET-KUT® GOLD

Letter Size Bits - M2 135° Split Point - Bronze Oxide (Gold) Finish Super Premium

- Same quality features as JET-KUT® Gold jobber bits in popular letter size instead of fractional sizes

PROD. NO.	Size	Pkg. Qty.	Tap size (inches)
570906	F	12	5/16 - 1/8NC
570921	U	6	7/16 - 14NC



TORQUE DRIVE®

JET-KUT® Gold*

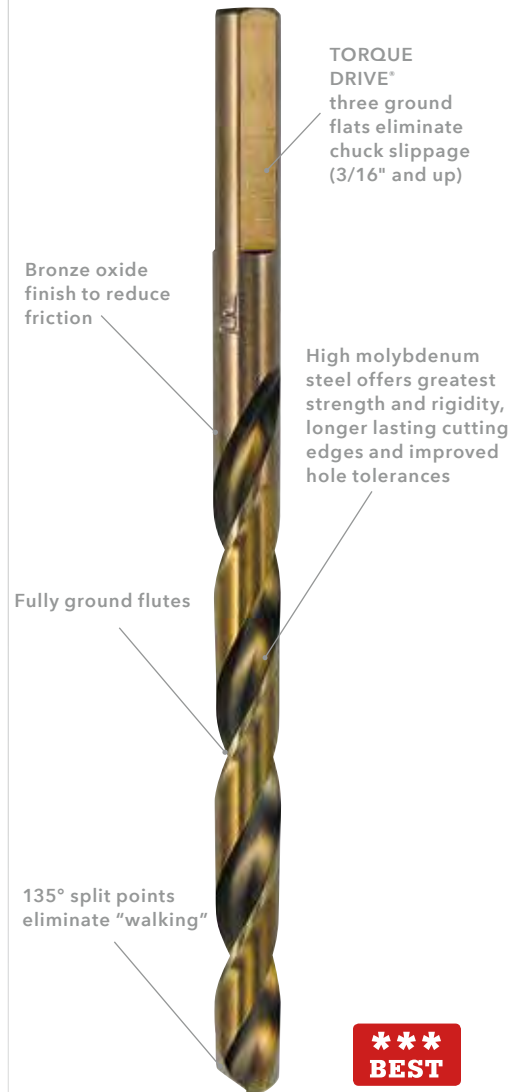



TORQUE DRIVE

JET-KUT® Gold*



570358

BEST**



570143

JET-KUT® GOLD

**Twin End Drill Bits M2 H.S.S Bronze Oxide (Gold) Finish
Super Premium (for Drills and Drill Presses)**

- Twin cutting ends allow twice the cutting performance and life
- Same quality features as JET-KUT® Gold jobber bits



PROD. NO.	Size (inches)	Overall Length (inches)	Pkg. Qty.
570358	1/8	1-15/16	12

JET-KUT® GOLD

Drill Bit Sets - Super Premium (for Drills and Drill Presses)

- Premium 135° split point - gold finish
- Strong metal box to protect and organize your bits



PROD. NO.	MOD. NO.	Pieces	Description
570141	GF21R	21	1/16" through 1/4" by 64ths and 9/32" through 1/2" by 32nds
570142	GF29	29	1/16" through 1/2" by 64ths
570143	GF29RS	29	1/16" through 1/2" by 64ths, sizes 25/64" - 1/2" are 3/8" reduced shank



JET-KUT® GOLD

Prentice Drill Bits M2 118° Split Point Bronze Oxide (Gold) Finish Super Premium (for Drills and Drill Presses)

- Made from heavy duty high molybdenum, hardened steel for increased consistency and greater wear resistance
- Flutes are ground to extremely tight tolerances for increased accuracy and consistency in the point and split grinding process, resulting in more accurate hole sizes
- Flutes have a thin nitro-carburized surface to provide extra wear resistance along the cutting edge of the point
- Special flute form enhances chip ejection, reduces drill retractions (woodpeckering) and improves coolant flow to the tip
- Split point provides the drill with self-centring/non-walking characteristics by giving the drill two starting points
- The superior bronze oxide (gold) ground flute finish reduces friction, allowing outstanding drilling performance with less operator pressure
- JET offers TORQUE DRIVE® three ground flats on the shank to provide a strong positive chuck grip virtually eliminating the potential for the drill to slip in the chuck
- The thin web of the JET-KUT® Gold prentice bit permits fast feed rates which make it ideal for drilling work on hardened steels such as 304, 306, and 316 stainless steel



PROD. NO.	Size (inches)	Shank dia. (inches)	Pkg. Qty.
570436	9/16	1/2	1
570440	5/8	1/2	1
570444	11/16	1/2	1
570448	3/4	1/2	1
570452	13/16	1/2	1
570456	7/8	1/2	1
570460	15/16	1/2	1
570464	1	1/2	1
570472	1-1/8	1/2	1
570480	1-1/4	1/2	1



TORQUE DRIVE®

JET-KUT® Gold*

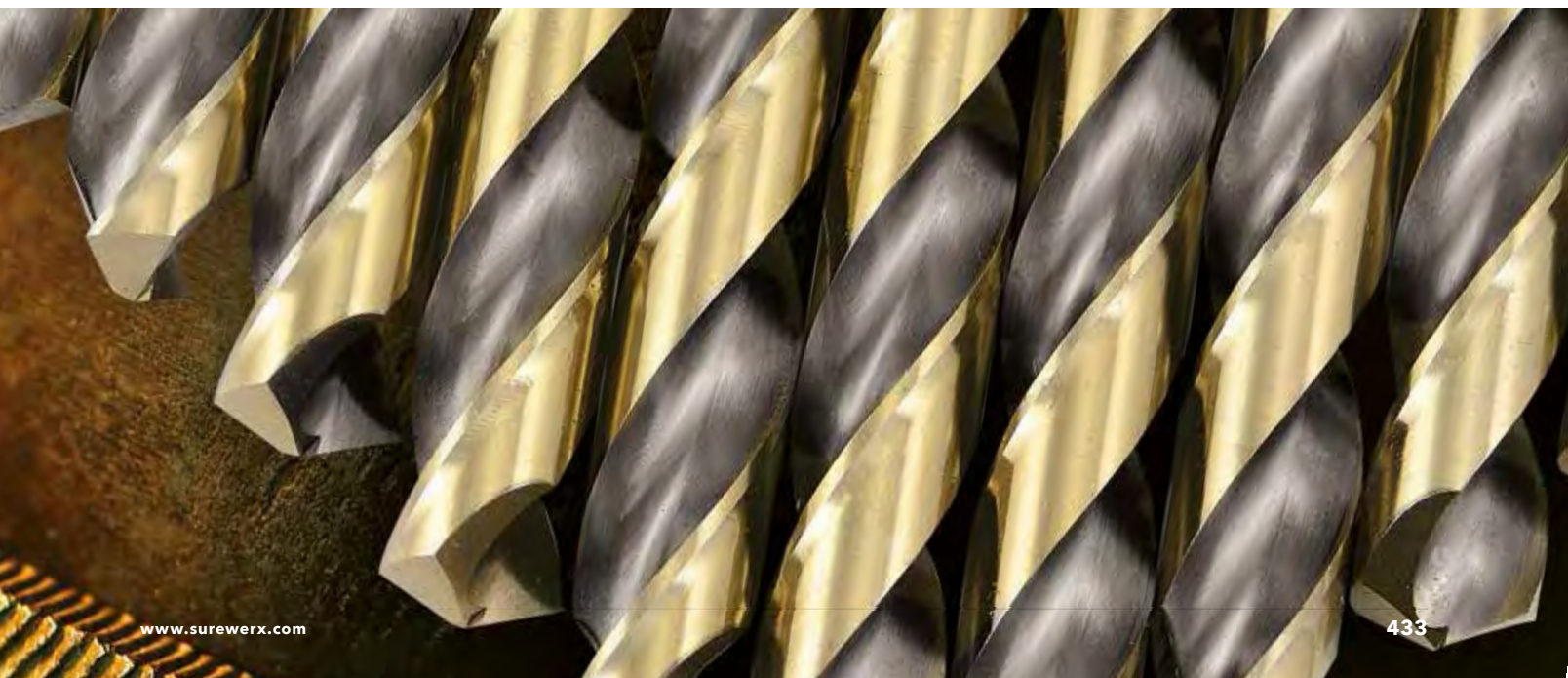



JET-KUT® Cobalt

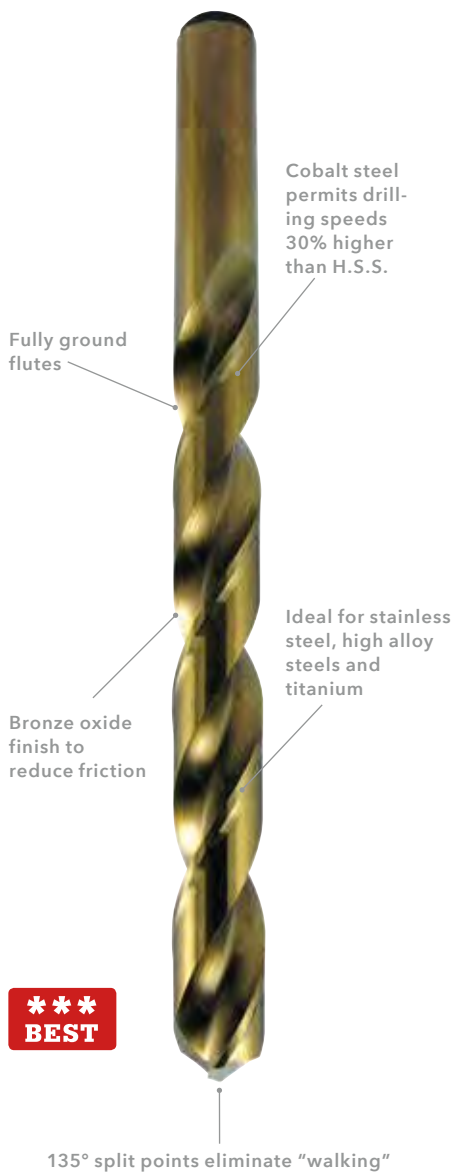

***** BEST**



570144

JET-KUT® COBALT

Jobber Length Drill Bits 135° Split Point Cobalt Steel Super Premium (for Drills and Drill Presses)

- Heavy duty bits for drilling hard tough metals, free machining stainless steel, high temperature alloys, titanium and certain plastics
- High red hardness allows 30% higher drilling speeds over regular high speed steel drill bits
- Feature razor sharp 135° split point self centring tips, eliminating "walking" and the need for centre punching.
- The superior bronze oxide (gold) ground flute finish reduces friction, translating to less operator pressure, and longer life
- Special flute form enhances chip ejection, reduces drill retractions (woodpeckering) and improves coolant flow to the tip
- For best results use in rigidly held positive feed drilling equipment



PROD. NO.	Size (inches)	Pkg. Qty.	PROD. NO.	Size (inches)	Pkg. Qty.
573404	1/16	12	573419	19/64	6
573405	5/64	12	573420	5/16	6
573406	3/32	12	573421	21/64	6
573407	7/64	12	573422	11/32	6
573408	1/8	12	573423	23/64	6
573409	9/64	12	573424	3/8	6
573410	5/32	12	573425	25/64	6
573411	11/64	12	573426	13/32	6
573412	3/16	12	573427	27/64	6
573413	13/64	12	573428	7/16	6
573414	7/32	12	573429	29/64	6
573415	15/64	12	573430	15/32	6
573416	1/4	12	573431	31/64	6
573417	17/64	12	573432	1/2	6
573418	9/32	12			

JET-KUT® COBALT

29 PC Drill Bit Set Super Premium

- Strong metal box to protect and organize your bits
- Featuring the same high quality jobber length bits as offered in open stock
- 30% higher drilling speed over regular high speed steel drills



PROD. NO.	MOD. NO.	Package Quantity	Description
570144	GF29CB	29	1/16" through 1/2" by 64ths



579326



JET-KUT® B&G
Car Reamers Black & Gold Finish
Premium (for Drills and Drill Presses)

- Used for enlarging existing drilled or formed holes in structural steel plates
- Aggressive fast spiral reamers made of high tungsten tool steel for maximum life
- Black and gold surface treated body and clearance, cuts cooler and stays sharp longer
- Right hand cut with left hand spiral prevents tool from hogging into the hole
- Three flat shanks prevent slippage in chuck
- Stop collar reduces possibility of impact damage to chuck
- Ideal for reaming applications on truck frames, bridges, pressure vessels and rail cars



PROD. NO.	Size (inches)	Point Dia. (inches)	Min. starting hole size (inches)	Overall length (inches)	Shank Dia. (inches)
579326	3/8	.250	5/16	5-7/8	1/2
579328	1/2	.281	3/8	5-7/8	1/2
579330	5/8	.343	7/16	6-3/4	1/2
579333	3/4	.406	1/2	6-3/4	1/2

JET-KUT®
Step Drills M35 Split Point
Super Premium (for Drills and Drill Presses)

- Ideal for hole making in sheet metal and other thin materials
- M35 high speed steel stays sharp longer for fast cutting and long service life
- Split point, two flute design provides fast penetration and maximum chip clearance
- Gold finish minimizes heat build up and reduces friction, increasing life and performance
- TORQUE DRIVE® three flat shank prevents slipping in chuck



PROD. NO.	Size (inches)	No. of hole sizes	Shank size (inches)	Step Increments (inches)	Step Thickness (inches)	Overall Length (inches)
579202	1/8 - 1/2	13	1/4	1/32	9/64	3-1/8
579204	3/16 - 1/2	6	1/4	1/16	3/8	3-1/8
579206	3/16 - 7/8	12	3/8	1/16	9/64	3-1/4
579208	1/4 - 3/4	9	3/8	1/16	9/64	2-3/4
579212	1/4 - 1	10	3/8	*below	5/32	3-1/4
579214	1/4 - 1-3/8	11	3/8	**below	9/64	3-1/4

* 1/4, 13/32, 9/16, 5/8, 11/16, 3/4, 13/16, 7/8, 15/16, 1"

** 1/4, 25/64, 35/64, 11/16, 13/16, 7/8, 1, 1-1/8, 1-7/32, 1-1/4, 1-3/8"

TORQUE DRIVE®



579202

JET-KUT[®]

TAPS & DIES



- Made of hardened and tempered M2 High Speed Steel for fast threading and long service life
- SAE taps available in taper, plug and bottom chamfers to perform all threading applications. Accurate threading provided by precision ground 3 or 4 flute design
- Ideal for industrial applications (production work) as well as automotive, agri-motive and machine shop applications
- Rockwell Hardness: HRC 62-64

JET-KUT®
SUPER PREMIUM TAPS & DIES

Size	Taper	Plug	Bottom	Drill Size (inches)
# 4 - 40NC		530208		#43
# 4 - 48NF		530308		3/32
# 6 - 32NC		530214		7/64
# 6 - 40NF		530314		#33
# 8 - 32NC	530216	530217	530218	#29
#10 - 24NC	530219	530220	530221	#25
#10 - 32NF	530319	530320	530321	5/32
#12 - 24NC	530222	530223	530224	#16
1/4" - 20 NC	530225	530226	530227	13/64
1/4" - 28 NF	530325	530326	530327	7/32
5/16" - 18 NC	530228	530229	530230	F
5/16" - 24NF	530328	530329	530330	17/64
3/8" - 16NC	530231	530232	530233	5/16
3/8" - 24NC	530331	530332	530333	21/64
7/16" - 14 NC	530234	530235	530236	U
7/16" - 20 NF	530334	530335	530336	25/64
1/2" - 13 NC	530237	530238	530239	27/64
1/2" - 20 NF	530337	530338	530339	29/64
9/16" - 12 NC	530240	530241	530242	31/64
9/16" - 18 NF	530340	530341	530342	33/64
5/8" - 11 NC	530243	530244	530245	17/32
5/8" - 18 NF	530343	530344	530345	37/64
3/4" - 10 NC	530246	530247	530248	21/32
3/4" - 16 NF	530346	530347	530348	11/16
7/8" - 9 NC	530252	530253	530254	49/64
7/8" - 1/4 NF	530352	530353	530354	13/16
1" - 8 NC	530258	530259	530260	7/8
1" - 12 NF	530358			59/64
1-1/8" - 7 NC	530264	530265	530266	63/64
1-1/8" - 12 NF	530364	530365	530366	1-3/64
1-1/4" - 7 NC	530270	530271	530272	17/64
1-1/4" - 12 NF	530370	530371	530372	1-11/64
1-3/8" - 6NC	530276			1-7/32
1-3/8" - 12NF	530376			1-19/64
1-1/2" - 6 NC	530282			1-11/32

NC - National Course
 NF - National Fine (SAE)
 NPT - National Pipe Thread





JET-KUT®
SUPER PREMIUM TAPS & DIES



530560

JET-KUT®
M2 H.S.S. Metric Taps - Super Premium

- Made of hardened and tempered M2 High Speed Steel for fast threading and long service life
- Metric taps available in taper, plug and bottom chamfers to perform all threading applications. Accurate threading provided by precision ground 3 or 4 flute design
- Ideal for industrial applications (production work) as well as automotive, agri-motive and machine shop applications
- Rockwell Hardness: HRC 62-64

Size	Taper	Plug	Bottom	Drill Size (mm)
3mm - 0.50		530509		2.5
3mm - 0.60		530609		2.4
3.5mm - 0.60		530512		2.9
4mm - 0.70		530514		3.3
4mm - 0.75		530614		3.25
5mm - 0.80	530520	530521	530522	4.2
5mm - 0.90		530621		4.1
6mm - 0.75		530524		5.2
6mm - 1.00	530623	530624	530625	5.0
7mm - 0.75		530527		6.2
7mm - 1.00		530627		6.0
8mm - 1.00		530530		7.0
8mm - 1.25	530629	530630	530631	6.8
9mm - 1.00		530533		8.0
9mm - 1.25		530633		7.8
10mm - 1.25	530535	530536	530537	8.8
10mm - 1.50	530635	530636	530637	8.6
11mm - 1.50		530539		9.6
12mm - 1.50	530541	530542	530543	10.5
12mm - 1.75	530641	530642	530643	10.5
14mm - 1.50	530544	530545	530546	12.5
16mm - 2.00	530547	530548	530549	14
18mm - 1.50	530553	530554	530555	16.5
18mm - 2.50		530551		15.5
20mm - 2.50		530560		17.5
22mm - 1.50		530566		20.5
24mm - 2.00		530572		22
24mm - 3.00		530573		21

JET-KUT®

Alloy NPT Hex Taps - Premium

- Standard Hex design for threading and rethreading applications
- JET-KUT® dies are produced with premium grade 9 SiCr alloy materials for extended life and maximum performance
- Rockwell Hardness: HRC 55-59

PROD. NO.	Size (inches)	Type	Drill Size (inches)
530401	1/8 - 27NPT	Taper	11/32
530402	1/4 - 18NPT	Taper	7/16
530403	3/8 - 18NPT	Taper	37/64
530404	1/2 - 14NPT	Taper	45/64
530406	3/4 - 14 NPT	Taper	29/32
530408	1 - 11-1/2 NPT	Taper	1-5/32
530409	1-1/4 - 11-1/2 NPT	Taper	1-12
530410	1-1/2 - 11-1/2NPT	Taper	1-47/64
530412	2 - 11-1/2 NPT	Taper	2-7/32

JET-KUT®

Tap Accessories

- JET-KUT® tap accessories are produced with premium grade materials for extended life and maximum performance

PROD. NO.	Description
530955	Adjustable Tap Wrench for 1/16" to 3/8" Taps
530956	Adjustable Tap Wrench for 1/4" to 3/4" Taps
530957	Adjustable Tap Wrench for 3/8" to 1" Taps



JET-KUT® PREMIUM TAPS & DIES



530401



530957





530960

Standard T-handle

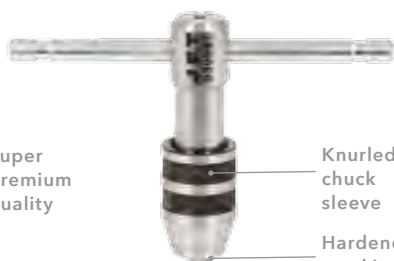

Super premium quality

530981

Positive, left, or right ratchet with centre lock position



Super premium quality

530991



JET-KUT® T-Handle Tap Wrenches

- JET-KUT® tap accessories are produced with premium grade materials for extended life and maximum performance

PROD. NO.	Description
530960	For 1/16" to 3/16" Taps
530961	For 1/4" to 1/2" Taps

JET-KUT® Tap Wrenches - Super Premium

- JET-KUT® tap wrenches are perfect for creating straight and accurate thread holes in your workpiece
- Self-centering hardened steel jaws and knurled chuck sleeve for added durability
- Specially designed sliding T-handle for fitting into tight spaces with greater leverage
- These versatile tap wrenches can be used with reamers, drill bits, screw extractors, and other hand-turned tools

PROD. NO.	Description
530981	For #0 - 1/4" (2 mm - 6 mm)
530984	For #12 - 1/2" (6 mm - 12 mm)

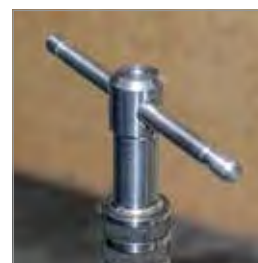

JET-KUT® Ratchet Tap Wrench - Super Premium

- Features a fine tooth ratcheting mechanism which adjusts on the fly for right and left-handed use
- Ratchet can be locked to transform the tool into a standard tap wrench
- Positive, left, or right ratchet with centre lock position increases performance and efficiency
- Ratcheting mechanism offers increased performance and efficiency

PROD. NO.	Description
530991	For #0 - 1/4" (2 mm - 6 mm)
530994	For #12 - 1/2" (6 mm - 12 mm)

- Standard hex design for threading and re-threading applications
- JET-KUT® dies are produced with premium grade 9 SiCr alloy materials for extended life and maximum performance
- Rockwell Hardness: HRC 55-59

Size	1" Hex	1-7/16" Hex	1-13/16" Hex
# 4 - 40NC	530703		
# 4 - 48NF	530753		
# 6 - 32NC	530705		
# 6 - 40NF	530755		
# 8 - 32NC	530707		
#10 - 24NC	530709		
#10 - 32NF	530759		
#12 - 24NC	530712		
1/4 - 20NC	530722		
1/4 - 28NF	530772		
5/16 - 18NC	530724		
5/16 - 24NF	530774		
3/8 - 16NC	530726		
3/8 - 24NC	530776		
7/16 - 14NC	530728		
7/16 - 20NF	530778		
1/2 - 13NC	530730		
1/2 - 20NF	530780		
9/16 - 12NC		530732	
9/16 - 18NF		530783	
5/8 - 11NC		530734	
5/8 - 18NF		530784	
3/4 - 10NC		530736	
3/4 - 16NF		530786	
7/8 - 9NC			530738
7/8 - 14NF			530788
1 - 8NC			530740
1 - 14NF			530741

NC - National Course
 NF - National Fine (SAE)
 NPT - National Pipe Thread



530728





JET-KUT®

Steel Alloy Metric Hex Dies - Premium

- Standard hex design for threading and re-threading applications
- JET-KUT® dies are produced with premium grade 9 SiCr alloy materials for extended life and maximum performance
- Rockwell Hardness: HRC 55-59



530846

Size	1" Hex	1-7/16" Hex	1-13/16" Hex
3mm - 0.5	530803		
3mm - 0.6	530853		
3.5mm - 0.6	530805		
4mm - 0.7	530807		
4mm - 0.75	530857		
5mm - 0.8	530811		
5mm - 0.9	530861		
6mm - 0.75	530815		
6mm - 1	530865		
7mm - 0.75	530817		
7mm - 1	530867		
8mm - 1	530819		
8mm - 1.25	530869		
9mm - 1	530821		
9mm - 1.25	530871		
10mm - 1	530822		
10mm - 1.25	530823		
10mm - 1.5	530873		
11mm - 1.5	530825		
12mm - 1.25	530826		
12mm - 1.5	530827		
12mm - 1.75	530877		
14mm - 1.5		530831	
16mm - 1.5		530834	
16mm - 2		530835	
18mm - 1.5		530838	
18mm - 2.5		530839	
20mm - 2.50			530841
22mm - 1.50			530843
24mm - 2.00			530845
24mm - 3.00			530846

Alloy NPT Hex Dies - Premium

- Standard Hex design for threading and rethreading applications
- JET-KUT® dies are produced with premium grade 9 SiCr alloy materials for extended life and maximum performance
- Rockwell Hardness: HRC 55-59

PROD. NO.	Size (inches)	Type	Diameter (inches)
530903	1/8 - 27NPT	Die	1 Hex
530904	1/4 - 18NPT	Die	1-1/16 Hex
530905	3/8 - 18NPT	Die	1-1/4 Hex
530906	1/2 - 14NPT	Die	1-7/16 Hex
530908	3/4 - 14NPT	Die	1-13/16 Hex
530910	1 - 11-1/2NPT	Die	2-3/16 Hex



JET-KUT®

Die Accessories

- JET-KUT® tap and die accessories are produced with premium grade materials for extended life and maximum performance

PROD. NO.	Description
530965	SAE Thread Pitch Gauge
530966	Metric Thread Pitch Gauge
530951	1" Hex Die Stock
530952	1-7/16" Hex Die Stock



530965



530951



JET-KUT®
PREMIUM TAPS & DIES



530116



530117



530118



530120



JET-KUT®
Alloy Tap and Die Sets - Premium



40 PC SAE Alloy Tap and Die Set 530116 / TD40A

- **One of each:** plug tap, hex die # 4-40, #6-32, #8-32, #10-24, #10-32, #12-24, 1/4-20, 1/4-28, 5/16-18, 5/16-24, 3/8-16, 3/8-24, 7/16-14, 7/16-20, 1/2-20, 1/8-27NPT
- Tap wrench: 1 long handle adjustable, 1 T-handle 1/16-3/16 shank taps
- Hex die stock: 1 (1)
- Screwdriver: 1 slot
- Pitch gauge: 1 SAE thread
- Blow mould case: 1

40 PC Metric Alloy Tap and Die Set 530117 / TD40AM

- **One of each:** plug tap, hex die 3mm-0.50, 3mm-0.60, 4mm-0.70, 4mm-0.75, 5mm-0.80, 5mm-0.90, 6mm-0.75, 6mm-1.00, 7mm-0.75, 7mm-1.00, 8mm-1.00, 8mm-1.25, 10mm-1.25, 10mm-1.50, 12mm-1.50, 12mm-1.75, 1/8-27NPT
- Tap wrench: 1 long handle adjustable, 1 T-handle 1/16-3/16 shank taps
- Hex die stock: 1 (1)
- Screwdriver: 1 slot
- Pitch gauge: 1 metric thread
- Blow mould case: 1

76 PC SAE/Metric Alloy Tap and Die Set 530118 / TD76A

- **One of each:** plug tap, hex die #4-40, #6-32, #8-32, #10-24, #10-32, #12-24, 1/4-20, 1/4-28, 5/16-18, 5/16-24, 3/8-16, 3/8-24, 7/16-14, 7/16-20, 1/2-20, 3mm-0.50, 4mm-0.70, 4mm-0.75, 5mm-0.80, 5mm-0.90, 6mm-1.00, 7mm-1.00, 8mm-1.00, 8mm-1.25, 9mm-1.00, 9mm-1.25, 10mm-1.25, 10mm-1.50, 11mm-1.5, 12mm-1.50, 12mm-1.75, 1/8-28BSP, 1/8-27NPT
- Tap wrench: 1 adjustable, 1/8-1/2 taps, 1 T-handle 1/16-3/16 shank taps, 1 T-handle 1/4-1/2 shank taps
- Hex die stock: 1 (1) and 1 (5/8)
- Screwdriver: 1 slot
- Pitch gauge: 1 metric thread and 1 SAE thread
- Blow mould case: 1

110 PC SAE/Metric Alloy Tap and Die Set 530120 / TD110A

- **One of each:** plug tap, bottom tap, die #4-40, #6-32, #8-32, #10-24, #10-32, #12-24, 1/4-20, 1/4-24, 1/4-28, 1/4-32, 5/16-18, 5/16-24, 3/8-16, 3/8-24, 7/16-14, 7/16-20, 1/2-13, 1/2-20, 9/16-12, 9/16-18, 5/8-11, 5/8-18, 3/4-10, 3/4-16, M6-1.00, M8-1.25, M10-1.50, M10-1.0, M11-1.5, M12-1.25, M12-1.75, M14-1.50, M18x1.5, 1/8-27NPT, 1/8-18NPT
- Tap wrench: 1 adjustable, 1/16-1/2 (M3-M12) 1 adjustable, 1/4-3/4 (M6-M20), 1 T-type handle
- Die handle : 1" (M25) O.D 1" (M38) O.D.
- Metal case: 1

- Sets **530106**, **530107** and **530108** contain H.S.S. taps for extra long life and improved performance



JET-KUT®
SUPER PREMIUM TAPS & DIES

40 PC SAE H.S.S. Tap and Alloy Die Set **530106** / TD40H

- **One of each:** plug tap, hex die #4-40, #6-32, #8-32, #10-24, #10-32, #12-24, 1/4-20, 1/4-28, 5/16-18, 5/16-24, 3/8-16, 3/8-24, 7/16-14, 7/16-20, 1/2-20, 1/8-27NPT
- Tap wrench: 1 long handled adjustable 1 T-handle 1/16-3/16 shank taps
- Hex die stock: 1 (1)
- Screwdriver: 1 slot
- Pitch gauge: 1 SAE thread
- Blow mould case: 1



530106

40 PC Metric H.S.S. Tap and Alloy Die Set **530107** / TD40HM

- **One of each:** plug tap, hex die 3mm-0.50, 3mm-0.60, 4mm-0.70, 4mm-0.75, 5mm-0.80, 5mm-0.90, 6mm-0.75, 6mm-1.00, 7mm-0.75, 7mm-1.00, 8mm-1.00, 8mm-1.25, 10mm-1.25, 10mm-1.50, 12mm-1.50, 12mm-1.75, 1/8-27NPT
- Tap wrench: 1 long handled adjustable, 1 T-handle 1/16-3/16 shank taps
- Hex die stock: 1 (1)
- Screwdriver: 1 slot
- Pitch gauge: 1 metric thread
- Blow mould case: 1



530107

76 PC SAE/Metric H.S.S. Tap and Alloy Die Set **530108** / TD76H

- **One of each:** plug tap, hex die #4-40, #6-32, #8-32, #10-24, #10-32, #12-24, 1/4-20, 1/4-28, 5/16-18, 5/16-24, 3/8-16, 3/8-24, 7/16-14, 7/16-20, 1/2-20, 3mm-0.50, 4mm-0.70, 4mm-0.75, 5mm-0.80, 5mm-0.90, 6mm-1.00, 7mm-1.00, 8mm-1.00, 8mm-1.25, 9mm-1.00, 9mm-1.25, 10mm-1.25, 10mm-1.50, 11mm-1.5, 12mm-1.50, 12mm-1.75, 1/8-28bps, 1/8-27NPT
- Tap wrench: 1 adjustable, 1/8-1/2 taps 1 T-handle 1/16- 3/16 shank taps, 1 T-handle 1/4-1/2 shank taps
- Hex die stock: 1 (1), 1 (5/8)
- Screwdriver: 1 slot
- Pitch gauge: 1 metric thread, 1 SAE thread
- Blow mould case: 1



530108





Improved tooth geometry for faster cutting and longer life.



565106



565119



565132

JET-KUT® Bi-Metal Holesaws Premium (For Drills & Drill Presses)

- Improved tooth geometry increases cutting speed and life by up to 29%
- 4/6 tooth configuration for faster, smoother cuts with less vibration
- Enlarged, offsetting slots for easy plug removal



PROD. NO.	Size (inches)	Diameter	Arbor No.	Pipe Tap Size (inches)	Pipe Entrance Size (inches)
565102	5/8	15.5mm	M24R, M34, M44	3/8	3/8
565104	3/4	19.0mm		1/2	3/8
565106	7/8	22.2mm		3/4	1/2
565108	1	25.4mm		3/4	1/2
565110	1-1/8	28.8mm		1	3/4
565115	1-1/4	31.8mm		M45, M45P, M55P	1-1/4
565117	1-3/8	34.9mm		1-1/4	1
565119	1-1/2	38.1mm		1-1/4	1
565121	1-5/8	41.2mm		1-1/4	1
565123	1-3/4	44.5mm		1-1/2	1-1/4
565125	1-7/8	47.6mm		1-1/2	1-1/4
565126	2	50.8mm		1-1/2	1-1/2
565128	2-1/8	53.9mm		1-1/2	1-1/2
565129	2-1/4	57.2mm		2	1-1/2
565131	2-3/8	60.3mm		2	1-1/2
565132	2-1/2	63.5mm		M45P, M55P	2-1/2
565135	2-3/4	69.9mm		2-1/2	2
565137	3	76.2mm		2-1/2	2
565139	3-1/4	82.6mm		3	2
565141	3-1/2	88.9mm		3	2
565142	3-5/8	92.0mm		3	3
565145	4	101.6mm		3-1/2	3
565146	4-1/8	105.0mm		3-1/2	3-1/2
565149	4-1/2	114.3mm		3-1/2	4
565153	5	127.0mm		3-1/2	4
565161	6	152.4mm		3-1/2	4

PROD. NO.	MOD. NO.	Shank Size (inches)	Thread Size (inches)	Holesaw Size (inches)	Use Pilot Drill No.	Fits Arbor No.
565180	M24R	1/4 Round	1/2 - 20	9/16 - 1-3/16	MPD4S	Adjustable pilot bit
565182	M34	3/8 Hex	1/2 - 20	9/16 - 1-3/16	MPD4S	Hexagonal shank
565183	M44	7/16 Hex	1/2 - 20	9/16 - 1-3/16	MPD4	Hexagonal shank
565184	M45	3/8 Hex	1/2 - 20	1-1/4 - 2-3/8	MPD4	Hexagonal shank
565185	M45P	7/16 Hex	1/2 - 20	1-1/4 - 6	MPD4S	Lock push pins into the hole saw backing plate
565186	M55P	7/16 Hex	1/2 - 20	1-1/4 - 6	MPD4	Quick change

JET-KUT®
PREMIUM BI-METAL HOLESAWS



565183

565185

565186



565191



565192

JET-KUT®
Holesaw Accessories

Pilot Drill Bits

PROD. NO.	MOD. NO.	Fits Arbor No.	Feature
565191	MPD4S	565182 (M34) 565185 (M45P)	3" long x 1/4" shank
565192	MPD4	565180 (M24R), 565183 (M44), 565184 (M45), 565185 (M45P) 565186 (M55P)	4" long x 1/4" shank with 3 notches for set screw

Holesaw Arbor Adapter Set

565188 / AA1258

- Holesaw arbor adapter can be used with holesaws with 5/8-18 threads to 1/2-20 threads



12" Holesaw Arbor Extension

565196 / ME12

- 12" arbor extension, use with **565183** (M44) and **565185** (M45P) arbors





JET-KUT® HOLESAW KITS

Premium Bi-Metal

Improved tooth geometry for faster cutting and longer life.

JET-KUT

PREMIUM BI-METAL HOLESAWS



565207



565206



565208



565205

11 PC Maintenance Holesaw Kit 565207

- Designed for plumbers, electricians, industrial and general purpose maintenance, this kit contains 9 plumbing and electrical sizes for pipe and conduit through 2-1/2"
- Set includes 1 of each:
 - 565104 (3/4", 19.0mm)
 - 565106 (7/8", 22.2mm)
 - 565110 (1-1/8", 28.8mm)
 - 565117 (1-3/8", 34.9mm)
 - 565119 (1-1/2", 38.1mm)
 - 565123(1-3/4", 44.5mm)
 - 565126 (2", 50.8mm)
 - 565129 (2-1/4", 57.2mm)
 - 565132 (2-1/2", 63.5mm)
 - 565180 (M24R, 1/4" Round)
 - 565185 (M45P, 7/16" Hex)
 - Plastic case

8 PC Electrician's Starter Holesaw Kit 565206

- Designed for electricians, this starter kit contains entrance sizes for pipe and conduit through 2-1/2"
- Set includes 1 of each:
 - 565106 (7/8", 22.2mm)
 - 565110 (1-1/8", 28.8mm)
 - 565117 (1-3/8", 34.9mm)
 - 565123 (1-3/4", 44.5mm)
 - 565126 (2", 50.8mm)
 - 565132 (2-1/2", 63.5mm)
 - 565180 (1/4" Round)
 - 565185 (7/16" Hex)
 - Plastic case

12 PC Electrician's Master Holesaw Kit 565208

- Designed for electricians, this contains entrance sizes for pipe and conduit from 1/2" through 4"
- Set includes 1 of each:
 - 565106 (7/8", 22.2mm)
 - 565110 (1-1/8", 28.8mm)
 - 565117 (1-3/8", 34.9mm)
 - 565123 (1-3/4", 44.5mm)
 - 565126 (2", 50.8mm)
 - 565132 (2-1/2", 63.5mm)
 - 565137 (3", 76.2mm)
 - 565142 (3-5/8", 92.0mm)
 - 545146 (4-1/8", 105.0mm)
 - 565149 (4-1/2", 114.3mm)
 - 565183 (M44, 7/16" Hex)
 - 565185 (M45P, 7/16" Hex)
 - Plastic case

8 PC Plumber's Holesaw Kit 565205

- Designed for plumbers, this kit contains sizes for pipe through 2-1/4"
- Set includes 1 of each:
 - 565104 (3/4", 19.0mm)
 - 565106 (7/8", 22.2mm)
 - 565110 (1-1/8", 28.8mm)
 - 565119 (1-1/2", 38.1mm)
 - 565123 (1-3/4", 44.5mm)
 - 565129 (2-1/4", 57.2mm)
 - 565180 (1/4" Round)
 - 565185 (7/16" Hex)
 - Plastic case

JET-KUT[®]

FILES





JET-KUT® PREMIUM ENGINEERING FILES

- JET-KUT® Premium Engineering Files are cut from high chrome alloy steel for increased hardness and strength
- The files then go through a process of annealing where the blank is heated to a high temperature and then cooled slowly under controlled conditions to soften the steel for tooth cutting and to ensure uniformity in the internal structure
- The teeth are then formed by a hardened chisel that cuts into the soft blank, raising the steel into the desired tooth formation
- All JET-KUT® files are then heated to a controlled temperature and then quenched in a special quenching solution. This process is repeated to ensure maximum hardness of the cutting edge
- The file is then straightened without reducing hardness to ensure the entire surface delivers maximum cutting performance
- A series of tests are then performed by trained inspectors to ensure a high quality cutting tool every time



ENGINEERING AND SAW FILES - AMERICAN PATTERN

Bastard Cut

The standard cut used for shaping and dressing steels and castings (coarse cut)

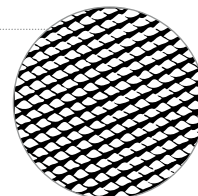

Second Cut

For hard metals (medium cut)

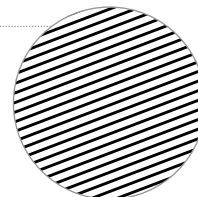

Smooth Cut

For hard metals and for use as a finish file (fine cut)

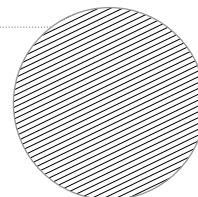

Rasp Cut

A rough cut primarily used on wood, hooves, aluminum and lead

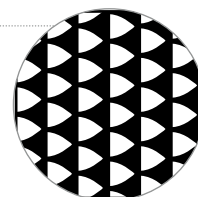

Flat Files - Premium

- Regular square section, tapers off in both width and thickness toward the point
- Double cut on both sides, single cut on edges
- **APPLICATION:** General purpose, used for smoothing surfaces and rapidly removing sharp edges and burrs on iron and steel flatwork



PROD. NO.	Length (inches)	Type	Cut	Pkg. Qty.
531306	6	Flat	Bastard	12
* 531308	8	Flat	Bastard	12
* 531310	10	Flat	Bastard	12
* 531312	12	Flat	Bastard	6
531314	14	Flat	Bastard	6

531326	6	Flat	Second	12
531328	8	Flat	Second	12
531330	10	Flat	Second	12
531332	12	Flat	Second	6
531334	14	Flat	Second	6

531346	6	Flat	Smooth	12
* 531348	8	Flat	Smooth	12
* 531350	10	Flat	Smooth	12
* 531352	12	Flat	Smooth	6
531354	14	Flat	Smooth	6

Half Round Files - Premium

- Half round style is flat on one side and curved on the other
- Tapers toward the point and has double cut sides
- **APPLICATION:** Used for filing both flat and concave surfaces, rounding out holes as well as leaving a smooth finish



PROD. NO.	Length (inches)	Type	Cut	Pkg. Qty.
531406	6	Half Round	Bastard	12
* 531408	8	Half Round	Bastard	12
* 531410	10	Half Round	Bastard	12
* 531412	12	Half Round	Bastard	6
531414	14	Half Round	Bastard	6

531426	6	Half Round	Second	0
531428	8	Half Round	Second	12
531430	10	Half Round	Second	12
531432	12	Half Round	Second	6
531434	14	Half Round	Second	0

531446	6	Half Round	Smooth	6
531448	8	Half Round	Smooth	12
531450	10	Half Round	Smooth	12
531452	12	Half Round	Smooth	6
531454	14	Half Round	Smooth	6

* Also available in carded format.
Please note: Bulk files sold in package quantities only



531346

531428

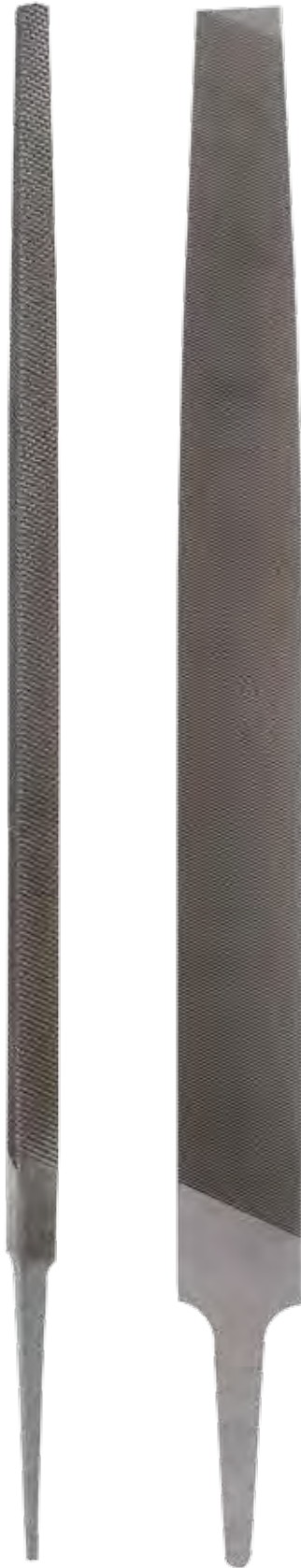

531910

531514

JET-KUT®

Mill Files - Premium

- Regular square section, tapers in width toward the point
- Two square edges, single cut on both sides and edges
- **APPLICATION:** General purpose used for sharpening saws, axes, farm tools and other edged tools, also used in lathe work, draw filing and finishing of hard material

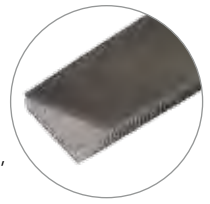

PROD. NO.	Length (inches)	Type	Cut	Pkg. Qty.
531506	6	Mill	Bastard	12
* 531508	8	Mill	Bastard	12
* 531510	10	Mill	Bastard	12
* 531512	12	Mill	Bastard	6
531514	14	Mill	Bastard	6

531526	6	Mill	Second	12
531528	8	Mill	Second	12
531530	10	Mill	Second	12
531532	12	Mill	Second	6

531548	8	Mill	Smooth	12
531550	10	Mill	Smooth	6
531552	12	Mill	Smooth	6

JET-KUT®

Square Files - Premium

- Square section, tapers toward the point
- Double cut on all sides
- **APPLICATION:** Used for filing square holes, rectangular grooves, keyways, inside corners and general surface filing



PROD. NO.	Length (inches)	Type	Cut	Pkg. Qty.
531906	6	Square	Bastard	12
531908	8	Square	Bastard	12
531910	10	Square	Bastard	12

531926	6	Square	Second	12
531928	8	Square	Second	12
531930	10	Square	Second	12

531946	6	Square	Smooth	12
531948	8	Square	Smooth	12
531950	10	Square	Smooth	12

* Also available in carded format.
Please note: Bulk files sold in package quantities only

JET-KUT®

Round Files - Premium

- Round section, tapers toward the point
- Bastard and 2nd cut file is double cut, smooth is single cut
- **APPLICATION:** Designed to file or enlarge holes, circular openings or rounded grooves too small for half round file



PROD. NO.	Length (inches)	Type	Cut	Pkg. Qty.
531606	6	Round	Bastard	12
* 531608	8	Round	Bastard	12
* 531610	10	Round	Bastard	12
* 531612	12	Round	Bastard	6
531626	6	Round	Second	12
531628	8	Round	Second	12
531630	10	Round	Second	12
531632	12	Round	Second	6
531646	6	Round	Smooth	12
531648	8	Round	Smooth	12
531650	10	Round	Smooth	12
531652	12	Round	Smooth	6

JET-KUT®

Pipeliners Files - Premium

- Half round section is flat on one side and curved on the other
- Parallel in both width and thickness, single cut both sides
- **APPLICATION:** Designed specifically for use on steel pipe applications

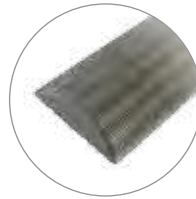

PROD. NO.	Length (inches)	Type	Cut	Pkg. Qty.
532542	14	Half Round Pipeliner	Bastard	6

JET-KUT®

Taper Saw Files - Premium

- Triangular section
- 60° angles between three sides, equal sides taper towards point, single cut edges and sides
- Cross dimensions become smaller on extra slim
- **APPLICATION:** Designed especially for use on saw and blade teeth. The slim cut is for sharpening saws with 6 to 8 teeth per inch and the x-slim cut is for sharpening saws with 8 to 13 teeth per inch



PROD. NO.	Length (inches)	Type	Cut	Pkg. Qty.
532522	6	Taper saw	Slim	12
532524	6	Taper saw	X slim	12

* Also available in carded format.

Please note: Bulk files sold in package quantities only

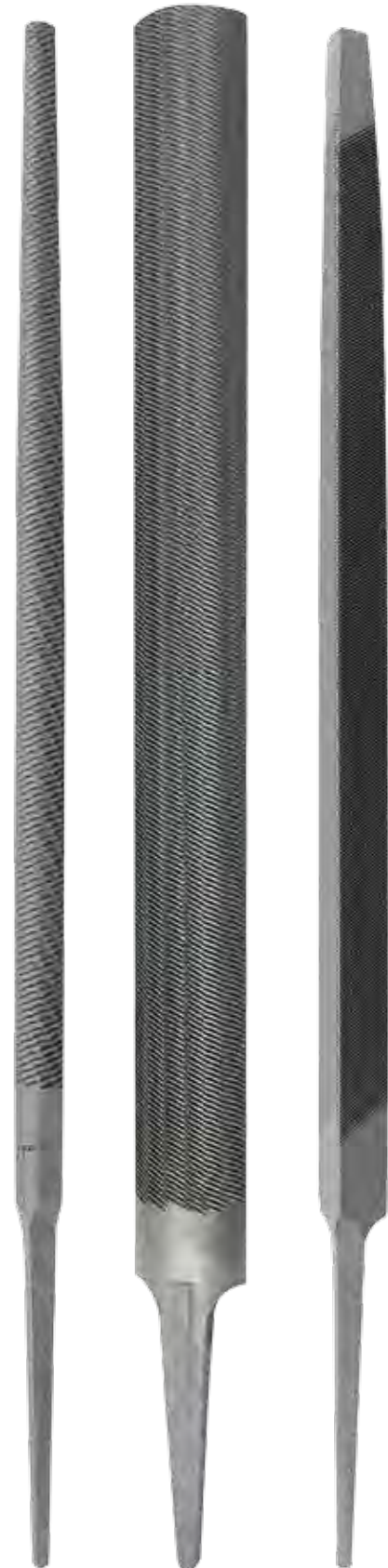

531606

532542

532522



531828

531205

531130

JET-KUT® Three Square Files - Premium

- Triangular section 60° angles between three sides
- Surface tapers toward the point, all sides are double cut
- **APPLICATION:** For filing internal angles or cleaning out corners inaccessible to flat files, also used for filing taps and cutters in the annealed state

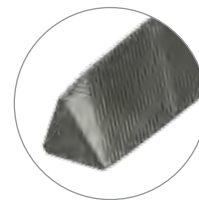

PROD. NO.	Length (inches)	Type	Cut	Pkg. Qty.
531806	6	3 Square	Bastard	12
531808	8	3 Square	Bastard	12
531810	10	3 Square	Bastard	12
531826	6	3 Square	Second	12
531828	8	3 Square	Second	12
531830	10	3 Square	Second	12
531846	6	3 Square	Smooth	12
531848	8	3 Square	Smooth	12
531850	10	3 Square	Smooth	12

JET-KUT® Chain Saw Files - Premium

- Special round file with special spiral double cut edges
- **APPLICATION:** Designed specifically for filing the collets of chain saws



PROD. NO.	Length (inches)	Type	Cut	Pk. Qty.
531205	8 x 5/32	Round	Double	12
*531206	8 x 3/16	Round	Double	12
*531207	8 x 7/32	Round	Double	12

JET-KUT® Farmers (Axe) Files - Premium

- Parallel in both width and thickness
- Self handled
- Single cut on both sides
- No cut on edges
- **APPLICATION:** General purpose files for sharpening axes, mowers, scythes and other edge tools

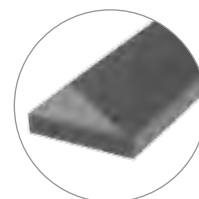

PROD. NO.	Length (inches)	Type	Cut	Pkg. Qty.
*531128	8	Farmer's	Second	12
531130	10	Farmer's	Second	12

* Also available in carded format.
Please note: Bulk files sold in package quantities only

JET-KET Knife Files Premium



- Tapers in thickness to one sharp edge and also tapers in width towards the point
- Double cut on both sides, single cut on sharp edge, back is uncut
- **APPLICATION:** Primarily for filing acute angles, keyways, slots or wedge shaped openings

PROD. NO.	Length (inches)	Type	Cut	Pkg. Qty.
532008	8	Knife	Bastard	12
532048	8	Knife	Smooth	12



JET-KUT® Wood Rasps - Premium

- Half round style is flat on one side and curved on the other
- Single cut file teeth on edge
- **APPLICATION:** Used by woodworkers, hobbyists and plumbers on wood and soft metals

PROD. NO.	Length in inches	Type	Cut	Pkg. Qty.
532112	12	Half Round	Bastard	6



JET-KUT® 4 in 1 File - Premium

- Half round shape
- Has file section and rasp section on both flat side and half round side
- **APPLICATION:** Used for general purpose maintenance, and boat building by craftsmen and mechanics

PROD. NO.	Length (inches)	Type	Pkg. Qty.
532502	8	Half Round	12



ENGINEERS FILES - SETS



JET-KUT® 5 PC File Set - Premium

532811 / JFS-5V

- Designed for rapid material removal, blade sharpening, removing sharp edges and burs and smoothing rough surfaces
- Set of 5 files fits securely into durable vinyl pouch
- Set includes 1 of each:

- 531410** 10" Half Round Bastard
- 531510** 10" Mill Bastard
- 531308** 8" Flat Bastard
- 531548** 8" Mill Smooth
- 532522** 6" Slim Taper



JET-KUT® 9 PC File Set - Premium

532851 / JFS-9V

- Designed for general maintenance, rapid material removal, blade sharpening, removing sharp edges and burs, rounding holes and smoothing rough surfaces
- Double heat treated forged steel for durability
- High chrome content increases hardness and strength
- Set of 9 files fits securely into durable vinyl pouch
- Set includes 1 of each:

- 531410** 10" Half Round Bastard
- 531510** 10" Mill Bastard
- 531310** 10" Flat Bastard
- 531350** 10" Flat Smooth
- 531610** 10" Round Bastard
- 531408** 8" Half Round Bastard
- 531308** 8" Flat Bastard
- 531508** 8" Mill Bastard
- 532522** 6" Slim Taper

- JET's fastest selling files in a convenient carded format

PROD. NO.	Length (inches)	Type	Cut	Pkg. Qty.
532206	8	Farmer's axe	Second	1
532211	8	Chain saw	Double	2
532212	8 x 7/32	Chain saw	Double	2
532216	8	Flat	Bastard	1
532217	10	Flat	Bastard	1
532218	12	Flat	Bastard	1
532226	8	Flat	Smooth	1
532227	10	Flat	Smooth	1
532228	12	Flat	Smooth	1
532231	8	Half Round	Bastard	1
532232	10	Half Round	Bastard	1
532233	12	Half Round	Bastard	1
532246	8	Mill	Bastard	1
532247	10	Mill	Bastard	1
532248	12	Mill	Bastard	1
532261	8	Round	Bastard	1
532262	10	Round	Bastard	1
532263	12	Round	Bastard	1



532206

JET-KUT®

File Handles

- Full size impact plastic handles offer comfort and long service life
- Available in carded package with four different hole sizes, use the product number from the file handle selection chart to choose the correct handle for your file

PROD. NO.	MOD. NO.	Pkg. Qty.
532922	FH05	1
532924	FH075	1
532926	FH09	1
532929	FH012	1

File Handle Selection Chart

FILE TYPE	FILE LENGTH			
	6"	8"	10"	12"
Flat	532924	532926	532929	532929
Half Round	532924	532926	532929	532929
Mill	532924	532926	532929	532929
Round	532922	532922	532924	532926
3 Square	532922	532926	532926	
Chain Saw		532922		
Taper Saw	532922			



532922



JET-KUT®

Bi-Metal Hacksaw Blades Premium

- Made from high quality high speed steel teeth that are thermally treated then laser beam welded to a high carbon steel backing to produce a highly durable, flexible, and shatterproof blade
- An excellent performing, long lasting blade for a wide range of applications

PROD. NO.	Size (inches) L x W x T	Teeth TPI	Pkg. Qty.
566231	12 x 1/2 x 0.25	18	10/100
566232	12 x 1/2 x 0.25	24	10/100
566233	12 x 1/2 x 0.25	32	10/100



HACKSAWS

JET carries a complete range of hacksaws to meet the needs of every application. Refer to the Hand Tools section for more information.



12" Hacksaw - Heavy Duty
775306



12" Hacksaw - Heavy Duty
775307



12" Aluminum Hacksaw
775308

SAFETY GUIDE

ABRASIVES - THINK SAFETY FIRST

Statistics show that nearly half of all accidents involving abrasive wheels are due to unsafe systems of work or errors caused by the operator.

Following minor precautions can prevent major accidents from happening:

DO

1. Always handle and store wheels in a careful manner.
2. Visually inspect all wheels before mounting for possible damage.
3. Ensure operating speed of machine does not exceed speed marked on wheel, its blotter or container.
4. Check mounting flanges for equal size, relieved as required and correct diameter.
5. Use mounting blotters as required by ANSI standards.
6. Be sure work rest is properly adjusted on bench, pedestal and floor stand grinders.
7. Always use safety guard that covers a minimum of one-half (1/2) the abrasive wheel.
8. Allow newly mounted wheels to run at operating speed, with guard in place, for at least one minute before grinding.
9. Always wear safety glasses or some type of approved eye protection while grinding or cutting.
10. Turn off coolant before stopping wheel to avoid creating an out-of-balance condition.
11. Follow common sense safety considerations.

DO NOT

1. Don't use a wheel that has been dropped or appears to have been abused.
2. Don't force a wheel onto the machine or alter the size of the mounting hole. If a wheel does not fit the machine, get one that will.
3. Don't ever exceed maximum operating speed established for the wheel.
4. Don't use mounting flanges on which the bearing surfaces are not clean, flat and smooth.
5. Don't tighten the mounting nut excessively.
6. Don't grind on the side of conventional, straight or type 1 wheels.
7. Don't use a wheel on any machine that is not properly designed for the specific application of the wheel.
8. Don't start the machine until the safety guard is properly and securely in place.
9. Don't jam work into the wheel.
10. Don't stand directly in front of a grinding/cutting wheel whenever a machine is in operation.
11. Don't grind or cut material for which the wheel is not designed.

HAZARDS FROM ABRASIVE WHEELS INCLUDE:

- Selecting the wrong wheel type
 - Mounting wrong
 - Over speed
 - Inadequate guarding
 - Flying particles
 - Fire from sparks
 - Dust
 - Noise
- ... and many more

WARNING

Avoid inhalation of dust generated by grinding and cutting operations. Exposure to dust may cause respiratory ailments as well as irritation to eyes and skin. In most cases, a greater hazard is the exposure to the dust/fumes from the base material being ground or paint or coatings applied to it. Use approved NIOSH or MSHA respirators, safety glasses or face shields, gloves and protective clothing. Provide adequate ventilation to eliminate dust or to maintain dust levels below the permissible exposure level for nuisance dust as classified by OSHA. Refer to Material Safety Data Sheet found on our website at www.surewerx.com for further information.

IMPORTANT

This information is designed as a guide for the individual user of abrasive materials, whether in the employ of a large corporation or in the confines of a home work shop. It is based on the premise that grinding/cutting is a safe operation when a few basic rules are followed. This safety information should be used only as a guide. All products listed in this catalogue shall be used in accordance with safety regulations set by OSHA and by the directive described by the American National Safety Institute B7.1, the Canadian Standard Association Safety Code B-173-5 and by the American Brush Manufacturers Association covering: speed, safety guards, flanges, mounting procedures, general operating rules, handling, storage, and inspection of general machine conditions.



**SAFETY
AND
PRODUCTIVITY**

DESIGN

Intelligent use of materials such as composites and magnesium, as well as ergonomically oriented handles, exhausts, and grip materials for more comfort and less fatigue.

QUALITY

Rigorous QC and testing for reliability, durability, and longevity, backed up by industry-leading warranty

STANDARDS

Exact specifications to deliver on-the-job reliability.

AIR TOOLS



DID YOU KNOW?

We sell the complete air pneumatic tool component system as well as replacement parts to help you extend the life of your air tools and stay productive

AIR WRENCHES

PROD. NO.	Product Name	CFM	Min. Hose Size	Air Inlet
400005	1/4" Drive Ratchet Wrench	3	5/16"	1/4"
400007	1/4" Drive Mini Ratchet Wrench - Heavy Duty	3	3/8"	1/4"
400104	3/8" Drive Impact Wrench	3	3/8"	1/4"
400105	3/8" Drive Butterfly Impact Wrench	3	3/8"	1/4"
400108	3/8" Drive Ratchet Wrench	4	3/8"	1/4"
400109	3/8" Drive Ratchet Wrench - Heavy Duty	3	3/8"	1/4"
400110	3/8" Drive Magnesium Series Impact Wrench - Heavy Duty	3	3/8"	1/4"
400116	3/8" Drive Butterfly Impact Wrench - Heavy Duty	2	3/8"	1/4"
400140	3/8" Drive Composite Series Impact Wrench - Super Heavy Duty	3	3/8"	1/4"
400213	1/2" Drive Ratchet Wrench	4	3/8"	1/4"
400214	1/2" Drive Ratchet Wrench - Heavy Duty	3	3/8"	1/4"
400226	1/2" Drive Composite Series Mini Impact Wrench - Heavy Duty	4	3/8"	1/4"
400240	1/2" Drive Composite Series Impact Wrench - Super Heavy Duty	5	3/8"	1/4"
400245	1/2" Drive Magnesium Series Impact Wrench - Super Heavy Duty	5	3/8"	1/4"
400246	1/2" Drive Magnesium Series Impact Wrench - Super Heavy Duty (2" Extended Anvil)	5	3/8"	1/4"
400247	1/2" Drive Composite Series Impact Wrench - Super Heavy Duty	5	3/8"	1/4"
400252	1/2" Drive Impact Wrench - Heavy Duty	8	3/8"	1/4"
400256	1/2" Drive Impact Wrench - Heavy Duty (2" extended anvil)	8	3/8"	1/4"
400261	1/2" Drive Angled Impact Wrench - Heavy Duty	3	3/8"	1/4"
400309	3/4" Drive Impact Wrench - Heavy Duty	7	3/8"	1/4"
400312	3/4" Drive Magnesium Series Impact Wrench - Heavy Duty	5	3/8"	1/4"
400313	3/4" Drive Magnesium Series Impact Wrench - Super Heavy Duty	7	1/2"	3/8"
400340	3/4" Drive Composite Series Impact Wrench - Super Heavy Duty	7	1/2"	3/8"
400416	1" Drive "Ultra Lightweight" Impact Wrench (2" Anvil)	12	3/8"	3/8"
400417	1" Drive "Ultra Lightweight" Impact Wrench (6" Extended Anvil)	12	3/8"	3/8"
400421	1" Drive Magnesium Series Impact Wrench - Super Heavy Duty	10	3/4"	1/2"
400422	1" Drive Magnesium Series Impact Wrench - Super Heavy Duty (6" Extended Anvil)	10	3/4"	1/2"
400423	1" Drive Magnesium Series Impact Wrench - Super Heavy Duty (8" Extended Anvil)	10	3/4"	1/2"
400424	1" Drive Composite Series Impact Wrench - Super Heavy Duty	7	1/2"	3/8"
400426	1" Drive "Ultra Lightweight" Impact Wrench - Heavy Duty (2" Anvil)	10	1/2"	1/2"
400427	1" Drive "Ultra Lightweight" Impact Wrench - Heavy Duty (6" Extended Anvil)	10	1/2"	1/2"
400434	1" Drive Impact Wrench - Super Heavy Duty	9	1/2"	3/8"
400435	1" Drive Lightweight D-Handle Impact Wrench - Super Heavy Duty	9	1/2"	3/8"
400443	1" Drive Impact Wrench - Super Heavy Duty	10	1/2"	1/2"
400444	1" Drive Impact Wrench - Super Heavy Duty (6" Extended Anvil)	10	1/2"	1/2"
400455	1" Drive Impact Wrench (2" Extended Anvil)	10	3/4"	1/2"
400456	1" Drive D-Handle Impact Wrench (6" extended anvil)	10	3/4"	1/2"

AIR GRINDERS & CUT-OFF TOOLS

402109	.3 HP 1/4" Mini Die Grinder	4	3/8"	1/4"
402110	.3 HP 1/4" Mini 90° Angle Head Die Grinder	5	3/8"	1/4"
402113	.6 HP 1/4" 90° Angle Head Die Grinder - Heavy Duty	5	3/8"	1/4"
402114	.6 HP 1/4" Mini Die Grinder - Heavy Duty	5	3/8"	1/4"
402115	.6 HP 1/4" 6" Extended Die Grinder - Heavy Duty	5	3/8"	1/4"
402116	.9 HP 1/4" Die Grinder - Super Heavy Duty	6	3/8"	1/4"
402118	.3 HP 1/4" 115° Angle Head Die Grinder - Heavy Duty	4	3/8"	1/4"
402120	.3 HP 1/4" 90° Angle Head Die Grinder	4	3/8"	1/4"
402121	.6 HP 1/4" 3" Extended Die Grinder - Heavy Duty	5	3/8"	1/4"
402123	.9 HP 1/4" Die Grinder - Heavy Duty	6	3/8"	1/4"
402124	.9 HP 1/4" 6" Extended Die Grinder - Heavy Duty	6	3/8"	1/4"
402304	4" Angle Grinder	6	3/8"	1/4"
402305	5" Angle Grinder	6	3/8"	1/4"
402312	5" Angle Grinder - Super Heavy Duty	30	3/8"	1/4"
402313	5" Angle Grinder - Heavy Duty	4	3/8"	1/4"
402332	7" Angle Grinder - Super Heavy Duty	5	3/8"	1/4"
402333	7" Angle Grinder with Anti-Vibe Handle - Heavy Duty	6	3/8"	1/4"
409012	3" 90° Angle Head Cut-Off Tool - Heavy Duty	5	3/8"	1/4"
409014	3" Cut-Off Tool - Reversible - Heavy Duty	4	3/8"	1/4"
409015	3" Cut-Off Tool - Heavy Duty	5	3/8"	1/4"
409016	4" Cut-Off Tool - 6" Extended - Heavy Duty	4	3/8"	1/4"

	PROD. NO.	Product Name	CFM	Min. Hose Size	Air Inlet
SHEET METAL TOOLS, FASTENER TOOLS, AUTOMOTIVE SPECIALTY	404153	Nibbler - Up Stroke Type - Heavy Duty	7	3/8"	1/4"
	404163	Pistol Grip Air Shear - Heavy Duty	4	3/8"	1/4"
	404606	1/4" Hex Pistol Grip Screwdriver	4	3/8"	1/4"
	409001	3/16" Air Riveter - Heavy Duty	1	3/8"	1/4"
	409002	1/4" Air Riveter - Heavy Duty	1	3/8"	1/4"
	409007	3/16" Air Riveter - Super Heavy Duty	6	3/8"	1/4"
	409008	1/4" Air Riveter - Super Heavy Duty	10	3/8"	1/4"
	409042	Air Scraper Kit	4	3/8"	1/4"
	409141	Reciprocating Saw	7	3/8"	1/4"
AIR DRILLS	404412	3/8" Reversible Drill - Keyed Chuck - Heavy Duty	4	3/8"	1/4"
	404415	3/8" Reversible Drill - Keyed Chuck	4	3/8"	1/4"
	404418	3/8" Reversible Angle Head Drill - Heavy Duty	4	3/8"	1/4"
	404419	3/8" Reversible Drill - Keyless Chuck - Heavy Duty	4	3/8"	1/4"
	404422	1/2" Reversible Drill - Keyed Chuck - Heavy Duty	4	3/8"	1/4"
	404423	1/2" Drill - Keyed Chuck	3	3/8"	1/4"
	404424	1/2" Reversible Drill - Keyless Chuck - Heavy Duty	4	3/8"	1/4"
AIR HAMMERS	404123	.401 Shank Medium Barrel Air Hammer	4	3/8"	1/4"
	404124	.401 Shank Long Barrel Air Hammer	4	3/8"	1/4"
	404126	6 PC Air Hammer Kit - Super Heavy Duty	3	3/8"	1/4"
	404203	Straight Type Flux Chipper - Heavy Duty	14	1/2"	1/4"
	404208	Needle Scaler Kit - Heavy Duty	14	1/2"	1/4"
	404226	Straight Type Needle Scaler	9	1/2"	1/4"
	404228	Pistol Grip Type Needle Scaler	10	1/2"	1/4"
	404323	3" Stroke .580 Hex Chipping Hammer - Heavy Duty	25	1/2"	3/8"
	404324	4" Stroke .580 Hex Chipping Hammer - Heavy Duty	28	1/2"	3/8"
	404328	3" Stroke .680 Round Chipping Hammer - Heavy Duty	25	1/2"	3/8"
	404329	4" Stroke .680 Round Chipping Hammer - Heavy Duty	28	1/2"	3/8"
409131	.401 Shank Riveting Hammer - Heavy Duty	12	3/8"	1/4"	
409132	.498 Shank Riveting Hammer - Heavy Duty	16	3/8"	1/4"	
AIR SANDERS	403095	3" 90° Angle Head Sander - Heavy Duty	5	3/8"	1/4"
	403102	5" High Speed Sander	6	3/8"	1/4"
	403112	7" Vertical Sander	6	3/8"	1/4"
	403192	3" Mini Polisher Kit	4	3/8"	1/4"
	403201	6" Dual Action "Quiet" Random Orbit Sander - Heavy Duty	4	3/8"	1/4"
	403203	6" Dual Action Sander	10	3/8"	1/4"
	403212	6" Dual Action Random Orbit Non-Vac Sander - Heavy Duty	10	3/8"	1/4"
	403217	6" Dual Action Random Orbit Central-Vac Sander - Heavy Duty	10	3/8"	1/4"
	403351	Multi Head File Belt Sander Kit with Case - Heavy Duty	4	3/8"	1/4"
403355	3/4" x 20-1/2" File Belt Sander - Heavy Duty	4	3/8"	1/4"	
AIR SPRAY GUNS	409123	High Pressure Gravity Feed Spray Gun - Heavy Duty	8	3/8"	1/4"
	409124	HVLP Gravity Feed Spray Gun - Heavy Duty	11	3/8"	1/4"
	409128	High Pressure Spray Gun - Heavy Duty	125	3/8"	1/4"



TABLE OF CONTENTS

Air Tool Selection Guide.....462

Air Wrenches 465

3/8" Impact Wrenches.....	466-468	1" Impact Wrenches.....	476-480
1/2" Impact Wrenches.....	469-472	Ratchet Wrenches.....	481-482
3/4" Impact Wrenches.....	473-475		

Air Grinders & Cut-Off Tools 483

Die Grinders.....	484-489	Cut-Off Tools.....	493-494
Angle Grinders.....	490-492		

Sheet Metal Tools, Fastener Tools & Automotive Specialty 495

Nibbler/shear.....	496	Pistol Grip Screwdriver.....	500
Sheet Metal Tool Accessories.....	496	Fastener Tool Accessories.....	500
Reciprocating Saw.....	497	Air Scraper.....	500
Air Saw Accessories.....	497	Air Scraper Accessories.....	500
Air Rivet Guns.....	498-499		

Air Drills 501

Pistol Grip Drills.....	502-504	Air Drill Accessories.....	505
Angle Head Drill.....	505		

Air Hammers 507

.401 Shank Air Hammers.....	508-509	Flux Chippers/Needle Scalars.....	512-513
.401 Shank Air Hammers Accessories.....	509-510	Flux Chippers/Needle Scalars Accessories.....	513
Riveting Hammers.....	511	Chipping Hammers.....	514
		Chipping Hammers Accessories.....	514

Air Sanders 515

Mini Sanders.....	516	Random Orbital Sanders.....	518-519
Sanders.....	517	Random Orbital Accessories.....	519
Sanders Accessories.....	517	File Belt Sanders.....	520

Spray Guns 521

Air Spray Guns.....	522-523
Spray Gun Accessories.....	524

Air Line Tools 525

Filters, Regulators and Lubricators		Air Fittings	537
Sample Shop Air Piping Layout.....	526	How to Identify Plug Designs.....	539
Quality Features.....	527	I/M Industrial/Automotive Type.....	540
Air Regulators.....	528	L Type.....	540
Air Filters.....	529	A Type.....	541
Air Lubricators.....	530	U Universal Style Couplers.....	542
Filter, Regulator Combo.....	531	3-Way Connectors.....	542
FRL - 2 Piece.....	532-533	360° Swivel Connectors.....	542
FRL - 3 Piece.....	534-535	Air Blow guns.....	543-544
Filters, Regulators and Lubricators Accessories.....	536		

Air Hose and Hose Reels 545

Retractable Hose Reels.....	546	PVC Air Hoses.....	548
Hand Crank Reels.....	547	Recoil Air Hoses.....	549
Hose Reels Accessories.....	547	Safety Guide.....	550
Rubber Air Hoses.....	548-549	Warranty.....	552

ICON LEGEND

New

JET Exclusive

Super Heavy Duty

Composite

Magnesium

Chrome Molybdenum

Warning Note

AIR WRENCHES





3/8" IMPACT WRENCHES



3/8" Drive Butterfly Impact Wrench

400105 / AW375B

- Maximum torque: **75 ft/lb**
- Compact design permits use in confined spaces
- Butterfly style throttle allows instant, single hand direction changes and speed control
- 8 positive throttle settings for pre-set operating speeds
- Swivel mounted air inlet for easy access to tight spaces
- Rubber nose guard protects the front housing from damage
- Anvil features a snap ring socket retainer
- Motor components are hardened for longer service life
- Air inlet screen for extended motor life

Only 5-7/8" long!



Small diameter hammer casing and tapered nose for greater access

3/8" Drive Butterfly Impact Wrench - Heavy Duty

400116 / AW38BHD

- Industry's hardest hitting butterfly wrench - **85 ft/lb** of maximum torque in the palm of your hand!
- All this power from an amazingly compact, ergonomic tool – only 5-7/8" long
- Small diameter hammer casing tapers at the nose for improved access in hard-to-reach areas
- Butterfly style throttle allows instant, single hand direction changes and speed control
- 18 positive throttle settings for pre-set operating speeds
- Heavy duty swivel mounted air inlet for easy access to tight places
- Grease port on hammer casing for easy lubrication and longer service life
- Ideal for working on small fasteners in tight work spaces, a professional tool for professional users

PROD. NO. MOD. NO.	400105 AW375B	400116 AW38BHD
Square Drive	3/8"	3/8"
Max. Torque (ft/lb)	75	85
Working Torque (ft/lb)	10 - 65	10 - 60
Free Speed (RPM)	10,000	11,000
Standard Bolt Capacity	3/8"	3/8"
Overall Length	6-1/4"	5-7/8"
Avg. Air Consumption (cfm)	3	2.2
Min. Hose Size	3/8"	3/8"
Air Inlet (NPT)	1/4"	1/4"
Sound Pressure (dBA)	-	97.3
Vibration (m/s ²)	-	6.92
Product Weight	2.5 lb (1.13 kg)	1.8 lb (0.81 kg)

3/8" Drive Impact Wrench

400104 / AW375PX

- Maximum torque: **100 ft/lb**
- Built-in power regulator
- Convenient forward/reverse switch allows quick direction changes
- Comfortable trigger switch
- Rubber nose-piece protects housing
- Intake screen protects motor for extended life
- Ideal for general automotive work up to 3/8" bolt size, including transmission and exhaust system work

PROD. NO.	400104
MOD. NO.	AW375PX
Square Drive	3/8"
Max. Torque (ft/lb)	100
Working Torque (ft/lb)	60 - 70
Free Speed (RPM)	10,000
Standard Bolt Capacity	3/8"
Overall Length	5-1/4"
Avg. Air Consumption (cfm)	3
Min. Hose Size	3/8"
Air Inlet (NPT)	1/4"
Product Weight	2.5 lb (1.13 kg)



Lightweight, compact design ensures maximum operator comfort



3/8" IMPACT WRENCHES

3/8" Drive Composite Series Impact Wrench - Super Heavy Duty 400140 / AW375CSDP



"Push Through"
Forward/Reverse control
conveniently allows one
hand directional change

Incredibly lightweight - only 2.82 lb!

- Produces **360 ft/lb** of nut wrenching torque in reverse
- Ultimate power in reverse maximizes removal of stubborn rusted nuts
- Super strong composite body
- Incredibly lightweight – only 2.82 lbs!
- Twin Hammer mechanism provides more power and smooth, balanced impact blows for reduced vibration
- Modern "Up Hill – Soft Grip" pistol grip handle design provides incredible tool balance and operator comfort – ideal for long hours on the job
- "Push Through" Forward/Reverse control conveniently allows one hand directional change
- Dial type Forward/Reverse control knob positioned for ease of use, three forward and two reverse settings
- Muffled handle mounted air outlet adds to operator comfort and safety
- Specially treated anvil for long service life
- Air inlet screen for extended motor life
- A professional tool for professional users. Ideal for all automotive, industrial and farm service applications



Square Drive	3/8"
Max. Torque (ft/lb) - Forward/Reverse	320 / 360
Working Torque (ft/lb)	50 - 320
Free Speed (RPM)	10,000
Standard Bolt Capacity	1/2"
Overall Length	6.3"
Avg. Air Consumption (cfm)	4.3
Min. Hose Size	3/8"
Air Inlet (NPT)	1/4"
Sound Pressure (dBA)	94
Vibration (m/s ²)	3.8
Product Weight	2.82 lb (1.26 kg)



610203

TORQUE DRIVE®

3/8" DRIVE IMPACT SOCKET SETS

See page 78



610208



610201



610207



610217



610218

- Twin hammer mechanism provides more power and smooth, balanced impact blows for reduced vibration
- Muffled handle mounted air outlet adds to operator comfort and safety
- Air inlet screen for extended motor life
- A professional tool for professional users. Ideal for all automotive, industrial and farm service applications

1/2" Drive Impact Wrench - Heavy Duty

400252 / AW50AT

- Produces **550 ft/lb** of hard hitting torque
- Extremely popular traditional style 1/2" impact wrench design
- Steel hammer case and aluminum body offers superior protection and strength
- "Push Through" sideways Forward/Reverse control conveniently allows one hand directional change



Lightweight - only 5.7 lb!

1/2" Drive Impact Wrench - Heavy Duty (2" Extended Anvil)

400256 / AW50ATE

- Produces **550 ft/lb** of hard hitting torque
- 2" extended anvil for use in tire shops
- Same great features as **400252**

PROD. NO. MOD. NO.	400252 AW50AT	400256 AW50ATE
Square Drive	1/2"	1/2"
Max. Torque (ft/lb)	550	550
Working Torque (ft/lb)	350	350
Free Speed (RPM)	7,000	7,000
Standard Bolt Capacity	5/8"	5/8"
Overall Length	7-1/4"	9-1/4"
Avg. Air Consumption (cfm)	8	8
Min. Hose Size	3/8"	3/8"
Air Inlet (NPT)	1/4"	1/4"
Sound Pressure (dBA)	<90	<90
Vibration (m/s ²)	<0.4	<0.4
Product Weight	5.7 lb (2.57 kg)	6 lb (2.7 kg)



2" extended anvil for use in tire shops

Lightweight - only 6 lb!

For maximum performance we recommend 90 PSI air pressure.



1/2" IMPACT WRENCHES

Mini body style
Only 6" long!



"Push Through" Forward/
Reverse control conveniently allows one hand directional change

Ergonomic handle shaped to fit the operator's hand: Features finger grooves for comfort and control

Incredibly lightweight - only 2.6 lb!

QUIET SERIES



Lightweight - only 5.8 lbs!



Lightweight - only 6.1 lbs!

- Ultimate power in reverse maximizes removal of stubborn rusted nuts
- Twin hammer mechanism provides more power and smooth, balanced impact blows for reduced vibration
- Exceptionally well balanced tool for comfort and ease of handling
- Muffled handle mounted air outlet adds to operator comfort and safety
- Air inlet screen for extended motor life

1/2" Drive Composite Series Mini Impact Wrench - Heavy Duty 400226 / AW500CCO

- Produces **300 ft/lb** of torque in reverse
- Super strong state-of-the-art mini composite body allows access into tight spaces
- Quiet Series: low noise only 83 dBA
- A professional tool for professional users. Ideal for all automotive, industrial and farm service applications, especially in confined spaces and/or where reduced noise is desirable



1/2" Drive Magnesium Series Impact Wrench - Super Heavy Duty 400245 / AW500MSD

- Produces **600 ft/lb** of nut wrenching torque in reverse
- Modern "Up Hill - Soft Grip" pistol grip handle design provides incredible tool balance and operator comfort - ideal for long hours on the job
- Lever type Forward/Reverse control knob positioned for ease of use, three forward settings and reverse
- Specially treated anvil for long service life
- A professional tool for professional users. Ideal for all automotive, industrial and farm service applications



1/2" Drive Magnesium Series Impact Wrench - Super Heavy Duty (2" Extended Anvil) 400246 / AW500MSDE

- Produces **600 ft/lb** of nut wrenching torque in reverse
- 2" extended anvil for tire work
- Same great features as 400245



PROD. NO. MOD. NO.	400226 AW500CCO	400245 AW500MSD	400246 AW500MSDE
Square Drive	1/2"	1/2"	1/2"
Max. Torque (ft/lb) - Forward	300	550	550
Max. Torque (ft/lb) - Reverse	320	600	600
Working Torque (ft/lb) - Forward	250	500	500
Working Torque (ft/lb) - Reverse	300	550	550
Free Speed (RPM)	11,000	7,500	7,500
Standard Bolt Capacity	5/8"	5/8"	5/8"
Overall Length	6"	8-1/4"	10-1/4"
Avg. Air Consumption (cfm)	4	4.7	4.7
Min. Hose Size	3/8"	3/8"	3/8"
Air Inlet (NPT)	1/4"	1/4"	1/4"
Sound Pressure (dBA)	83	94.8	94.8
Vibration (m/s ²)	3.9	2.26	2.26
Product Weight	2.6 lb (1.17 kg)	5.8 lb (2.61 kg)	6.1 lb (2.75 kg)

1/2" IMPACT WRENCHES



- Ultimate power in reverse maximizes removal of stubborn rusted nuts
- Twin hammer mechanism provides more power and smooth, balanced impact blows for reduced vibration
- Muffled handle mounted air outlet adds to operator comfort and safety
- Air inlet screen for extended motor life
- A professional tool for professional users. Ideal for all automotive, industrial and farm service applications

1/2" Drive Compact Impact Wrench - Heavy Duty

400266 / AW500AMIHD

- Super Compact Size (4.3") and extremely lightweight (2.95 lb) for excellent access into confined work spaces
- Jumbo Hammer mechanism provides more power and smooth, balanced impact blows for reduced vibration
- Push through Forward/Reverse control conveniently allows one hand directional change with integral speed control, two forward and full reverse
- Muffled handle mounted air outlet adds to operator comfort and safety
- Modern "Up Hill - Soft Grip" pistol grip handle design provides incredible tool balance and operator comfort - ideal for long hours on the job



1/2" Drive Composite Series Impact Wrench - Super Heavy Duty

400247 / AW500CSD

- Produces **700 ft/lb** of nut wrenching torque in reverse
- Super strong composite body
- Dial type Forward/Reverse control knob positioned for ease of use, three forward and two reverse settings



Incredibly lightweight - only 4.25 lb!

1/2" Drive Composite Series Impact Wrench - Super Heavy Duty

400240 / AW500CSDP

- Produces **780 ft/lb** of nut wrenching torque in reverse (in 5-7 seconds)
- Will loosen a nut/bolt stuck at over **1,200 ft/lb** (in 15-20 seconds)
- Modern "Up Hill - Soft Grip" pistol grip handle design provides incredible tool balance and operator comfort - ideal for long hours on the job
- Dial type Forward/Reverse control knob positioned for ease of use, three forward and two reverse settings
- Specially treated anvil for long service life



"Push Through" Forward/Reverse control conveniently allows one hand directional change

Incredibly Lightweight - only 4.40 lb!

PROD. NO. MOD. NO.	400266 AW500AMIHD	400247 AW500CSD	400240 AW500CSDP
Square Drive	1/2"	1/2"	1/2"
Max. Torque (ft/lb) - Forward	450	650	685
Max. Torque (ft/lb) - Reverse	500	700	780
Working Torque (ft/lb) - Forward	360	550	585
Working Torque (ft/lb) - Reverse	400	600	680
Free Speed (RPM)	10,000	8,500	7,200
Standard Bolt Capacity	5/8"	5/8"	5/8"
Overall Length	4-1/4"	7-7/8"	7.3"
Avg. Air Consumption (cfm)	3.7	4.7	4.9
Min. Hose Size	3/8"	3/8"	3/8"
Air Inlet (NPT)	1/4"	1/4"	1/4"
Sound Pressure (dBA)	98	92.9	96
Vibration (m/s ²)	7.5	4.5	3.6
Product Weight	2.95 lb (1.34 kg)	4.25 lb (1.91 kg)	4.40 lb (1.98 kg)

AIR WRENCHES

1/2" IMPACT WRENCHES

1/2" ANGLE IMPACT WRENCH

**POWER
SPEED
UNRESTRICTED ACCESS**

**REACTIONLESS DESIGN
ELIMINATES KICKBACK**



Ferrous cylinder and end plate offer **5X** longer life and lower service / repair cost

Angle head uses a patented cooling/lubrication system to reduce the excessive heat on parts and increase the life of the tool

1-3/4" head depth



Extra thick angle head wall housing ensures longest life and increased durability

Middle handle exhaust with 360° adjustable deflector directs air way from operator and workpiece



Reinforced aluminum alloy die cast angle head with steel retaining nut for maximum durability

200 ft/lb max nut wrenching torque - 6,000 RPM

Conveniently located forward/reverse collar. z 2 positions in forward and full 200 ft/lb of power z in reverse

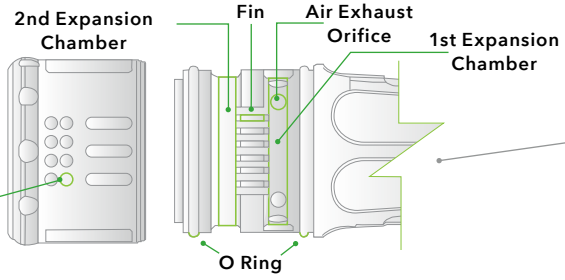

Patented exhaust mechanism uses a built-in twin expansion chamber divided by air flow guide fins to reduce exhaust noise without losing the power

The enhanced control features, combined with 200 ft/lb of max torque, allow technicians to use it for virtually any garage application

400261 / AW500AIWHD

AND MORE

- **200 ft/lb** hard hitting torque for hard to reach places
- Power and speed of an impact and the reach of a ratchet
- Patented cooling / lubrication system to reduce excessive heat and increase life of the tool
- 2,100 blows per minute

Square Drive	1/2"	Overall Length	13-3/8"
Max. Torque (ft/lb) - Forward	180	Avg. Air Consumption (cfm)	3
Max. Torque (ft/lb) - Reverse	200	Min. Hose Size	3/8"
Working Torque (ft/lb) - Forward	45 - 160	Air Inlet (NPT)	1/4"
Working Torque (ft/lb) - Reverse	45 - 180	Sound Pressure (dBA)	86
Standard Bolt Capacity	1/2"	Vibration (m/s ²)	7.5
		Product Weight	4.35 lb (1.95 kg)

For maximum performance we recommend 90 PSI air pressure.

3/4" IMPACT WRENCHES



- Ultimate power in reverse maximizes removal of stubborn rusted nuts
- Twin hammer mechanism provides more power and smooth, balanced impact blows for reduced vibration
- Muffled handle mounted air outlet adds to operator comfort and safety
- Air inlet screen for extended motor life
- A professional tool for professional users. Ideal for all automotive, industrial and farm service applications

3/4" Drive Magnesium Series Impact Wrench - Heavy Duty

400312 / AW19MHD

- Produces **600 ft/lb** of nut wrenching torque in reverse
- Modern "Up Hill – Soft Grip" pistol grip handle design provides incredible tool balance and operator comfort – ideal for long hours on the job
- Lever type Forward/Reverse control knob positioned for ease of use, three forward settings and reverse



PROD. NO. MOD. NO.	400312 AW19MHD
Square Drive	3/4"
Max. Torque (ft/lb) - Forward/Reverse	550 / 600
Working Torque (ft/lb) - Forward/Reverse	500 / 550
Free Speed (RPM)	7,500
Standard Bolt Capacity	5/8"
Overall Length	8-1/4"
Avg. Air Consumption (cfm)	4.7
Min. Hose Size	3/8"
Air Inlet (NPT)	1/4"
Sound Pressure (dBA)	97.2
Vibration (m/s ²)	2.26
Product Weight	5.9 lb (2.66 kg)



Lightweight - only 5.9 lb!

For maximum performance we recommend 90 PSI air pressure.





3/4" IMPACT WRENCHES

3/4" Drive Impact Wrench - Heavy Duty

400310 / AW19THA

- Maximum torque: **1,000 ft/lb**
- Twin hammer impact mechanism provides more power and smooth, balanced impact blows for reduced vibration
- Forward and reverse valve is equipped with three forward and one reverse, positive throttle setting
- Handle exhaust for maximum operator comfort
- Insulating rubber handle cover for operator comfort and safety
- Steel hammer case offers superior protection
- Three piece construction allows quick easy maintenance
- Anvil features snap ring and pin hole type socket retainer
- Air inlet screen for extended motor life
- Replacement rubber handle cover (**905125**)



Pistol grip contoured to protect the throttle trigger

Lightweight - only 9.9 lb!

3/4" Drive Magnesium Series Impact Wrench - Super Heavy Duty

400313 / AW19MSD

- Produces **1,200 ft/lb** of nut wrenching torque in reverse
- Super strong magnesium body
- Ultimate power in reverse maximizes removal of stubborn rusted nuts
- Twin Hammer mechanism provides more power and smooth, balanced impact blows for reduced vibration
- Modern "Up Hill - Soft Grip" pistol grip handle design provides incredible tool balance and operator comfort - ideal for long hours on the job
- Muffled handle mounted air outlet adds to operator comfort and safety
- Specially treated anvil for long service life
- Air inlet screen for extended motor life
- A professional tool for professional users. Ideal for all automotive, industrial and farm service applications including truck, shock, frame and spring work



Dial type forward/reverse control knob positioned for ease of use, three forward settings and reverse

Lightweight - only 11.3 lb!



PROD. NO. MOD. NO.	400310 AW19THA	400313 AW19MSD
Square Drive	3/4"	3/4"
Max. Torque (ft/lb) - Forward	950	1,100
Max. Torque (ft/lb) - Reverse	1,000	1,200
Working Torque (ft/lb) - Forward	730	800
Working Torque (ft/lb) - Reverse	780	880
Free Speed (RPM)	6,500	5,500
Standard Bolt Capacity	7/8"	1-1/4"
Overall Length	9.2"	8-3/4"
Avg. Air Consumption (cfm)	7	7.0
Min. Hose Size	3/8"	1/2"
Air Inlet (NPT)	3/8"	3/8"
Sound Pressure (dBA)	96.8	95.3
Vibration (m/s ²)	9.62	2.64
Product Weight	9.9 lb (4.49 kg)	11.3 lb (5.09 kg)

3/4" Drive Composite Series Impact Wrench - Super Heavy Duty 400340 / AW19CSDP

- Produces **1,250 ft/lb** of nut wrenching torque in reverse
- Ultimate power in reverse maximizes removal of stubborn rusted nuts
- Super strong state-of-the-art composite body
- Incredibly lightweight – only 7.74 lbs
- Twin Hammer mechanism provides more power and smooth, balanced impact blows for reduced vibration
- Modern “Up Hill – Soft Grip” pistol grip handle design provides incredible tool balance and operator comfort – ideal for long hours on the job
- “Push Through” Forward/Reverse control conveniently allows one hand directional change
- Lever type control knob positioned for ease of use, three settings for forward and reverse
- Muffled handle mounted air outlet adds to operator comfort and safety
- Specially treated anvil for long service life
- Air inlet screen for extended motor life
- A professional tool for professional users. Ideal for all automotive, industrial and farm service applications including truck, shock, frame and spring work



Incredibly lightweight - only 7.74 lb!



Square Drive	3/4"
Max. Torque (ft/lb) - Forward	1,150
Max. Torque (ft/lb) - Reverse	1,250
Working Torque (ft/lb) - Forward	800
Working Torque (ft/lb) - Reverse	800
Free Speed (RPM)	6,800
Standard Bolt Capacity	1/2"
Overall Length	8.61
Avg. Air Consumption (cfm)	6.9
Min. Hose Size	1/2"
Air Inlet (NPT)	3/8"
Sound Pressure (dBA)	100.1
Vibration (m/s ²)	18.7
Product Weight	7.74 lb (3.51 kg)

Handle Cover

PROD. NO.	Description
905126	Replacement handle cover for 400313



905125



"Push Through"
Forward/Reverse control
conveniently allows one
hand directional change

Incredibly lightweight - only 7.7 lb!

QUIET SERIES



Super Heavy Duty and
incredibly lightweight - only 16.32 lb!

1" IMPACT WRENCHES

- Ultimate power in reverse maximizes removal of stubborn rusted nuts
- Twin hammer mechanism provides more power and smooth, balanced impact blows for reduced vibration
- Air inlet screen for extended motor life

1" Drive Composite Series Impact Wrench - Super Heavy Duty

400424 / AW25CSD

- Produces an incredible **1,400 ft/lb** of nut wrenching torque in reverse
- Super strong state-of-the-art composite body
- Incredibly lightweight – only 7.7 lbs! Almost three times lighter than traditional aluminum body 1" impact wrenches
- Ergonomic handle shaped to fit the operator's hand: Features finger grooves for comfort and control
- Exceptionally well balanced tool for comfort and ease of handling
- Dial type Forward/Reverse control knob positioned for ease of use, three forward and three reverse settings
- Muffled handle mounted air outlet adds to operator comfort and safety
- A professional tool for professional users. Ideal for all automotive, industrial and farm service applications including truck, shock, frame and spring work



1" Drive Lightweight Impact Wrench - Super Heavy Duty

400435 / AW25PSD

- Extremely powerful 1" impact wrench – produces **1,700 ft/lb** of torque in reverse!
- Pistol grip design allows access and maximum power in more confined spaces
- Forward and reverse valve is equipped with 3 positive forward throttle settings
- Handle exhaust for maximum operator safety and comfort
- Three piece construction allows quick, easy maintenance
- Ergonomic handle shaped to fit the operator's hand
- Anvil features pin hole and spring clip type socket retainer
- Capable of operating at 150 – 170 PSI air pressure
- A powerful, super heavy duty impact wrench designed for heavy use in industrial and heavy duty truck and equipment applications



1" Drive Impact Wrench - Super Heavy Duty

400434 / AW38PSD

- Extremely powerful 1" impact wrench – produces **1,800 ft/lb** of torque!
- Pistol grip design allows access and maximum power in more confined spaces
- Forward and reverse valve is equipped with 4 positive throttle settings
- Adjustable exhaust deflector for maximum operator safety and comfort
- Three piece construction allows quick, easy maintenance
- Anvil features pin hole and spring clip type socket retainer
- A powerful, super heavy duty impact wrench designed for heavy use in industrial and heavy duty truck and equipment applications



Capable of operating at
150 - 170 PSI air pressure

PROD. NO. MOD. NO.	400424 AW25CSD	400435 AW25PSD	400434 AW38PSD
Square Drive	1"	1"	1"
Max. Torque (ft/lb) - Forward	1,400	1,600	1,800
Max. Torque (ft/lb) - Reverse	1,500	1,700	1,800
Working Torque (ft/lb) - Forward	200 - 1,200	100 - 1,525	100 - 1,200
Working Torque (ft/lb) - Reverse	1,400	100 - 1,625	-
Free Speed (RPM)	5,500	5,000	4,000
Standard Bolt Capacity	1-1/4"	1"	1-1/4"
Overall Length	8-3/4"	10-3/4"	11-1/2"
Avg. Air Consumption (cfm)	7 or 198 (l/min)	9	9
Min. Hose Size	1/2"	1/2"	1/2"
Air Inlet (NPT)	3/8"	1/2"	1/2"
Sound Pressure (dBA)	90	111	86
Vibration (m/s ²)	10.2	16.4	0.6
Product Weight	7.7 lb (3.47 kg)	16.32 lb (7.40 kg)	26.4 lb (11.88 kg)



1" IMPACT WRENCHES

Back Saver Technology

- Ultra Lightweight
- Hard Hitting
- Better Life

1" Drive "Ultra Lightweight" Impact Wrench - Heavy Duty

- Produces an incredible **1,800 ft/lb** of nut wrenching torque in reverse
- Ultimate power in reverse maximizes removal of stubborn rusted nuts
- Ultra lightweight "Back Saver Technology" ensures maximum operator comfort and safety, and minimum fatigue during use
- Super strong aluminum body with bumpers
- Twin hammer mechanism provides more power and smooth, balanced impact blows for reduced vibration
- Unique curved D-handle design improves balance of tool when held sideways, improving user comfort and control
- Forward and reverse valve is equipped with three position throttle settings
- Exhaust outlet directs air away from operator when held in sideways position
- Three piece construction allows quick, easy maintenance
- Internally mounted throttle trigger for operator safety and convenience
- Anvil features pin hole and spring clip type socket retainer
- Air inlet screen for extended motor life



Incredibly lightweight - only 14.3 lbs!
Outstanding power to weight performance



6" extended anvil for use on truck wheels

Features special offset handle for extreme comfort, control and balance



For maximum performance we recommend 90 - 120 PSI air pressure.

(2" Anvil)

400426 / AW25LHD2

- The ideal tool for all jobs requiring hard hitting impact blows from a very compact, lightweight tool

(6" Extended Anvil)

400427 / AW25LHD6

- The ideal tool for all truck tire work and heavy duty jobs requiring hard hitting impact blows from a very compact, lightweight tool

PROD. NO. MOD. NO.	400426 AW25LHD2	400427 AW25LHD6
Square Drive	1"	1"
Max. Torque (ft/lb) - Forward	1,500	1,500
Max. Torque (ft/lb) - Reverse	1,800	1,800
Working Torque (ft/lb) - Forward	200 - 1,300	200 - 1,300
Working Torque (ft/lb) - Reverse	200 - 1,500	200 - 1,500
Free Speed (RPM)	6,000	6,000
Standard Bolt Capacity	1.49"	1.49"
Overall Length	12-3/4"	18-3/4"
Avg. Air Consumption (cfm)	10	10
Min. Hose Size	1/2"	1/2"
Air Inlet (NPT)	1/2"	1/2"
Sound Pressure (dBA)	92	92
Vibration (m/s ²)	11.5	11.5
Product Weight	14.3 lb (6.44 kg)	15.9 lb (7.16 kg)

1" IMPACT WRENCHES

Back Saver Technology



1" Drive "Lightweight" Impact Wrench - Super Heavy Duty

- Produces an incredible **2,100 ft/lb** of nut wrenching torque in reverse
- Ultimate power in reverse maximizes removal of stubborn rusted nuts
- Lightweight "Back Saver Technology" ensures maximum operator comfort and safety, and minimum fatigue during use
- Super strong aluminum body
- Twin hammer mechanism provides more power and smooth, balanced impact blows for reduced vibration
- D-handle design for maximum operator control
- Forward and reverse valve is equipped with three position throttle settings
- Exhaust outlet directs air away from operator
- Three piece construction allows quick, easy maintenance
- Internally mounted throttle trigger for operator safety and convenience
- Anvil features pin hole and spring clip type socket retainer
- Air inlet screen for extended motor life
- Spline drive available
- Our most powerful 1" impact wrench. Designed for heavy duty applications such as bridge work, ship building, structural steel work, heavy duty shop applications and wherever you need maximum hitting power

1" Drive Impact Wrench - Super Heavy Duty

400443 / AW25ASD2



Lightweight - only 22 lb!
Unheard of power to weight performance
Compare traditional models at over 30 pounds

1" Drive Impact Wrench - Super Heavy Duty (6" Extended Anvil) 400444 / AW25ASD6



Lightweight - only 24 lb!
Unheard of power to weight performance
Compare traditional models at over 30 pounds

PROD. NO. MOD. NO.	400443 AW25ASD2	400444 AW25ASD6
Square Drive	1"	1"
Max. Torque (ft/lb) - Forward	1,800	1,800
Max. Torque (ft/lb) - Reverse	2,100	2,100
Working Torque (ft/lb) - Forward	400 - 1,600	400 - 1,600
Working Torque (ft/lb) - Reverse	400 - 1,800	400 - 1,800
Free Speed (RPM)	5,000	5,000
Standard Bolt Capacity	1.65"	1.65"
Overall Length	16.2"	16.2"
Avg. Air Consumption (cfm)	10	10
Min. Hose Size	1/2"	1/2"
Air Inlet (NPT)	1/2"	1/2"
Sound Pressure (dBA)	93	93
Vibration (m/s ²)	13.7	13.7
Product Weight	22 lb (9.9 kg)	24 lb (11 kg)

For maximum performance we recommend
90 - 120 PSI air pressure.



1" IMPACT WRENCHES



2" Anvil

1" Drive D Handle Impact Wrench (2" Anvil)

400455 / AW25AD2

- Produces **1,900 ft/lb** of hard hitting torque
- Rocking dog hammer mechanism for power and durability
- D-handle design complete with side handle for maximum operator control
- Forward and reverse valve is equipped with position throttle settings
- Exhaust outlet directs air away from operator for maximum safety and comfort
- Three piece construction allows quick, easy maintenance
- Air inlet screen for extended motor life
- For maximum performance we recommend 90 - 120 PSI air pressure
- Ideal for truck and tractor tire work, agricultural and general shop applications



6" Extended Anvil

1" Drive D Handle Impact Wrench (6" Extended Anvil)

400456 / AW25AD6

- 6" extended anvil to access lug nuts in truck and tractor wheels
- Same quality features as **400455**

PROD. NO. MOD. NO.	400455 AW25AD2	400456 AW25AD6
Square Drive	1"	1"
Max. Torque (ft/lb) - Forward	1,900	1,900
Max. Torque (ft/lb) - Reverse	1,900	1,900
Working Torque (ft/lb) - Forward	1,500 - 1,650	1,500 - 1,650
Working Torque (ft/lb) - Reverse	1,500 - 1,650	1,500 - 1,650
Free Speed (RPM)	4,000	4,000
Standard Bolt Capacity	1.77"	1.77"
Overall Length	15.26"	21.26"
Avg. Air Consumption (cfm)	10	10
Min. Hose Size	3/4"	3/4"
Air Inlet (NPT)	1/2"	1/2"
Sound Pressure (dBA)	103.4	103.4
Vibration (m/s ²)	<0.4	<0.4
Product Weight	25.73 lb (11.60 kg)	28.73 lb (12.93 kg)

1/4" Drive Mini Ratchet Wrench - Heavy Duty

400007 / RW25HDM

- Our most powerful and compact 1/4" mini ratchet
- Slim profile head ideal for engine compartment and under-dash work
- Contoured composite housing cover with traction pad for maximum operator comfort and control
- Fully recessed throttle for easy grip
- Roll forged pawl is specially heated to limit spreading and extend service life
- Maximum torque: **25 ft/lb**

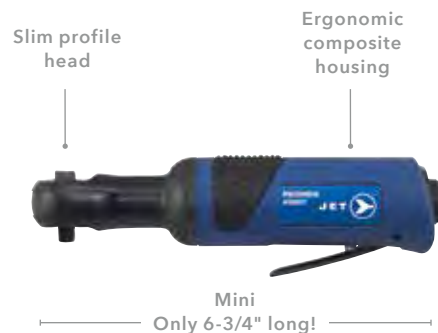

3/8" Drive Ratchet Wrench

400108 / RW375X

- Improved ratchet head assembly and motor design results in powerful torque output
- Fast 150 RPM head
- Ball type socket retainer allows quick socket changes
- Intake screen protects motor for extended life
- Ideal for a variety of automotive applications including exhaust system, water and fuel pump work, air conditioner, radiator and spark plug removal/replacement and general engine and body shop work
- Maximum torque: **50 ft/lb**



JET's most popular air ratchet!

1/2" Drive Ratchet Wrench - Heavy Duty

400109 / RW375HD

- This professional quality, heavy duty ratchet wrench features a high performance five blade motor, producing 70 ft/lb of torque. It is our most powerful ratchet wrench
- 360° swivel air inlet prevents twists in the hose for improved tool handling
- Ergonomic handle, with insulating and vibration absorbing rubber cover, for operator comfort and control
- Fully recessed throttle for easy grip
- Slim, low profile ratchet head and long neck design permits better access in tight work areas
- Roll forged pawl is specially heated to limit spreading and extend service life
- Maximum torque: **70 ft/lb**

360° swivel air inlet prevents hose twisting

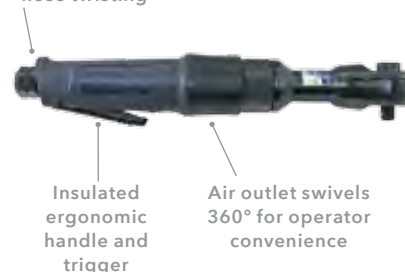

PROD. NO. MOD. NO.	400007 RW25HDM	400108 RW375X	400109 RW375HD
Square Drive	1/4"	3/8"	3/8"
Max. Torque by Hand (ft/lb)	70	70	120
Max. Torque by Air (ft/lb)	25	50	70
Free Speed (RPM)	250	150	160
Standard Bolt Capacity	3/8"	3/8"	3/8"
Overall Length	6-3/4"	10-1/4"	11-3/4"
Avg. Air Consumption (cfm)	2.55	4	2.6
Min. Hose Size	3/8"	3/8"	3/8"
Air Inlet (NPT)	1/4"	1/4"	1/4"
Sound Pressure (dBA)	89.1	-	90.8
Vibration (m/s ²)	2.32	-	1.93
Product Weight	1.15 lb (0.52 kg)	2.46 lb (1.11 kg)	2.8 lb (1.26 kg)

For maximum performance we recommend 90 PSI air pressure.



1/2" IMPACT WRENCHES



JET's most popular air ratchet!

1/2" Drive Ratchet Wrench 400213 / RW500X

- Improved ratchet head assembly and motor design results in powerful torque output
- Fast 150 RPM head
- Ball type socket retainer allows quick socket changes
- Intake screen protects motor for extended life
- Ideal for a variety of automotive applications including exhaust system, water and fuel pump work, air conditioner, radiator and spark plug removal/replacement and general engine and body shop work
- Maximum torque: **50 ft/lb**

360° swivel air inlet prevents hose twisting



Insulated ergonomic handle and trigger

Air outlet swivels 360° for operator convenience

1/2" Drive Ratchet Wrench - Heavy Duty 400214 / RW500HD

- Features a high performance five blade motor, producing 70 ft/lb of torque. It is our most powerful ratchet wrench
- 360° swivel air inlet prevents twists in the hose for improved tool handling
- Ergonomic handle, with insulating and vibration absorbing rubber cover, for operator comfort and control
- Fully recessed throttle for easy grip
- Air outlet swivels 360° allowing exhaust to be directed away from the operator
- Slim, low profile ratchet head and long neck design permits better access in tight work areas
- Roll forged pawl is specially heated to limit spreading and extend service life
- Maximum torque: **70 ft/lb**

PROD. NO. MOD. NO.	400213 RW500X	400214 RW500HD
Square Drive	1/2"	1/2"
Max. Torque by Hand (ft/lb)	70	120
Working Torque by Air (ft/lb)	50	70
Free Speed (RPM)	150	160
Standard Bolt Capacity	3/8"	3/8"
Overall Length	10-1/4"	11-3/4"
Avg. Air Consumption (cfm)	4	2.6
Min. Hose Size	3/8"	3/8"
Air Inlet (NPT)	1/4"	1/4"
Sound Pressure (dBA)	-	90.8
Vibration (m/s ²)	-	1.93
Product Weight	2.46 lb (1.11 kg)	2.8 lb (1.26 kg)



AIR GRINDERS & CUT-OFF TOOLS

483



DIE GRINDERS



.3 HP 1/4" Mini Die Grinder

402109 / MDG1-6

- Quality advances for longer service life include: steel end plate inserts, brass collar, reinforced air inlet and cylinder made of higher quality steel
- Mini length housing for use in confined areas
- All ball bearing construction and lever throttle with roller for positive speed control
- Self-locking throttle lever prevents accidental starting of motor
- Rear exhaust
- Built-in air regulator
- Ideal for multitude of applications using a wide range of accessories

Standard Accessories: Wrenches, 1/8" collet



.3 HP 1/4" Mini 90° Angle Head Die Grinder

402110 / MDG90

- Quality advances for longer service life include: steel end plate inserts, brass collar, reinforced air inlet and cylinder made of higher quality steel
- Precise bevel gear systems reduces speed for powerful confined area work
- Featuring deeper cut gears locked in place by slot and pin mechanism for improved service life
- All ball bearing construction and lever throttle for positive speed control
- Built-in air regulator
- Front exhaust

Standard Accessories: Wrenches, 1/8" collet

PROD. NO. MOD. NO.	402109 MDG1	402110 MDG90
Collet Size	1/4"	1/4"
Free Speed (RPM)	25,000	18,000
Overall Length	6-3/16"	5-3/16"
Avg. Air Consumption (cfm)	4	5
Min. Hose Size	3/8"	3/8"
Air Inlet (NPT)	1/4"	1/4"
Sound Pressure (dBA)	90	103
Vibration (m/s ²)	2.5	2.5
Product Weight	0.85 lb (0.38 kg)	1.05 lb (0.47 kg)



2-in-1 1/4" Die Grinder Combo Set

402149 / MDGKIT

- Includes 402109 and 402110
- Same quality tools as above, but in a convenient 2 piece set

DIE GRINDERS

JET Die Grinders - Simply the Best!

JET offers one of the most complete ranges of quality die grinders in the Canadian market place today. Simply put, JET die grinders are built and designed to provide the best performance, life and productivity of any brand. Over the past 10 years, JET has worked hard to overbuild this product range, ensuring each tool has the best components, bearings and motor housings in the business. Even our .3 HP standard duty grinders feature special components to ensure longevity. But it is our .6 and .9 HP models that stand above the rest. While the performance is similar to other, extremely high priced brands, the cost of these JET die grinders is amazingly competitive. That is why JET has quickly become the standard in the Canadian market and is the tool of choice for industrial and professional automotive users alike.



.3 HP 1/4" 90° Angle Head Die Grinder

402120 / MG90P

- Convenient, comfortable pistol grip design provides great operator control
- Compact overall length, perfect for working in tight areas
- Direct drive mechanism has fewer moving parts, for maximum tool life
- Ergonomic handle with finger grips and insulating cover
- Variable speed push button throttle
- Muffled handle exhaust directs air away from work piece

Standard Accessories: Wrenches

.3 HP 1/4" 115° Angle Head Die Grinder - Heavy Duty

402118 / DG115HD

- 115° head angle reduces operator fatigue, particularly on vertical work pieces
- Set RPM to match job using adjustable air regulator
- Swivel air inlet for ease of operation
- Insulated housing cover for operator comfort
- Throttle lever completely recessed in housing when fully engaged
- Safety toggle on throttle lever prevents accidental start-ups

Standard Accessories: Wrenches

PROD. NO. MOD. NO.	402120 MG90P	402118 DG115HD
Collet Size	1/4"	1/4"
Free Speed (RPM)	18,000	20,000
Overall Length	4-5/8"	7-5/8"
Avg. Air Consumption (cfm)	4	4
Min. Hose Size	3/8"	3/8"
Air Inlet (NPT)	1/4"	1/4"
Sound Pressure (dBA)	86	79
Vibration (m/s ²)	0.406	1.22
Product Weight	2.9 lb (1.31 kg)	1.25 lb (0.56 kg)

Only 4-5/8" long!



For maximum performance we recommend 90 PSI air pressure.



PROclub

BECOME A MEMBER

PROclub is an exclusive club built for professional workers like you. Members are first to hear about tools, equipment, and safety gear for the entire range of SureWerx brands. Activate your membership by visiting yourproclub.com and join Canada's premiere tool and safety community!

WHY JOIN?

- Take advantage of exclusive promotions
- Receive flyer deals
- New product sneak peeks
- Play interactive games
- Receive monthly newsletters
- Watch product videos and tutorials
- Enter contests to win prizes

JOIN PROCLUB TODAY AT YOURPROCLUB.COM



.6 HP 1/4" Mini Die Grinder - Heavy Duty

402114 / MG1HD

- Powerful .6 horsepower motor – our most popular die grinder
- Front exhaust, compact motor housing – only 5-3/4" long!
- Motor shaft features ball bearings front and back, and motor end plates are made from durable die cast aluminum metal for maximum life and performance
- Insulating vinyl cover for operator comfort and safety
- Lever throttle with roller tip for ease of operation
- Air inlet screen filters air line debris, extending motor life
- Outstanding power, performance, durability and life
- Ideal for most heavy duty industrial applications



Only 5-3/4" long!

.6 HP 1/4" 90° Angle Head Die Grinder - Heavy Duty

402113 / MG90HD

- Powerful .6 horsepower motor
- Rear exhaust, compact motor housing
- New improved drive gear system for longer life in heavy applications
- Motor shaft features ball bearings front and back, and motor end plates are made from durable die cast aluminum metal for maximum life and performance
- Insulating vinyl cover for operator comfort and safety
- Lever throttle with roller tip for ease of operation
- Air inlet screen filters air line debris, extending motor life
- Outstanding power, performance, durability and life
- Ideal for most heavy duty industrial applications

New motor housing with insulating vinyl cover



New, improved gear mechanism.

PROD. NO. MOD. NO.	402114 MG1HD	402113 MG90HD
Collet Size	1/4"	1/4"
Free Speed (RPM)	20,000	14,500
Overall Length	5-3/4"	7-1/2"
Avg. Air Consumption (cfm)	4.5	5
Min. Hose Size	3/8"	3/8"
Air Inlet (NPT)	1/4"	1/4"
Sound Pressure (dBA)	95	95
Vibration (m/s ²)	1.8	2
Product Weight	1.35 lb (0.61 kg)	2 lb (0.9 kg)



Small diameter nose extension design for narrow openings



3\"/>



6\"/>

DIE GRINDERS

- Powerful .6 horsepower motor
- Front exhaust, compact motor housing
- Motor shaft features ball bearings front and back, and motor end plates are made from durable die cast aluminum metal for maximum life and performance
- Features a special "coupling nut" which connects the motor to the extended shaft, for vibration absorption and easy dismantling during repairs
- Insulating vinyl cover for operator comfort and safety
- Lever throttle with roller tip for ease of operation
- Air inlet screen filters air line debris, extending motor life
- Outstanding power, performance, durability and life
- Ideal for most heavy duty industrial applications

.6 HP 1/4" 3" Extended Die Grinder - Heavy Duty

402121 / MG3HDE

- Coupler features a third ball bearing for longest life and smooth operation
- 3" extended shaft made from solid bar stock features three precision ball bearings, and the inside housing is precision machined and polished, ensuring an incredibly smooth, accurate performance, minimal run-out and longest life
- Fully polished, chrome plated extended shaft

Standard Accessories: Collet Wrenches

.6 HP 1/4" 6" Extended Die Grinder - Heavy Duty

402115 / MG6HDE

- 6" extended shaft features two large precision ball bearings offering a smooth, accurate performance, minimal run-out and longest life

Standard Accessories: Collet Wrenches

PROD. NO. MOD. NO.	402121 MG3HDE	402115 MG6HDE
Collet Size	1/4"	1/4"
Free Speed (RPM)	20,000	20,000
Overall Length	9-3/4"	12"
Avg. Air Consumption (cfm)	5.1	4.5
Min. Hose Size	3/8"	3/8"
Air Inlet (NPT)	1/4"	1/4"
Sound Pressure (dBA)	88	93
Vibration (m/s ²)	2.2	4.6
Product Weight	1.89 lb (0.85 kg)	2.72 lb (1.22 kg)

- Powerful .9 horsepower motor
- Air inlet screen filters airline debris, extending motor life
- Ideal for most heavy duty industrial applications

.9 HP 1/4" Die Grinder - Heavy Duty 402123 / MG19HD

- Motor shaft features ball bearings front and back, and motor end plates are made from durable die cast aluminum metal for maximum life and performance
- Insulating vinyl cover for operator comfort and safety
- Lever throttle with roller tip for ease of operation
- Outstanding power, performance, durability and life



Front exhaust, compact motor housing - only 6-1/2" long!

.9 HP 1/4" 6" Extended Die Grinder - Heavy Duty 402124 / MG69HDE

- Motor shaft features ball bearings front and back, and motor end plates are made from durable die cast aluminum metal for maximum life and performance
- Features a special "coupling nut" which connects the motor to the extended shaft, for vibration absorption and easy dismantling during repairs
- 6" extended shaft features two large precision ball bearings offering a smooth, accurate performance, minimal run-out and longest life
- Insulating vinyl cover for operator comfort and safety
- Lever throttle with roller tip for ease of operation
- Outstanding power, performance, durability and life



6" Extended Shaft
Front exhaust with a 360° swivel directs exhaust away from the operator

.9 HP 1/4" Die Grinder - Super Heavy Duty 402116 / DG149HD

- Our best high performance die grinder
- Housing precision machined from solid bar stock for superior strength
- Motor has two ball bearing construction, finely honed alloy steel cylinder and two steel end plates ensure maximum performance and life
- Rear exhaust directs air away from work piece

Standard Accessories: Collet Wrenches



Push button, self locking lever throttle for comfort, control and safety



PROD. NO. MOD. NO.	402123 MG19HD	402124 MG69HDE	402116 DG149HD
Collet Size	1/4"	1/4"	1/4"
Free Speed (RPM)	20,000	18,000	18,000
Overall Length	6-1/2"	12.86"	7-1/16"
Avg. Air Consumption (cfm)	6	6	6
Min. Hose Size	3/8"	3/8"	3/8"
Air Inlet (NPT)	1/4"	1/4"	1/4"
Sound Pressure (dBA)	93	90	92
Vibration (m/s ²)	2.5	2.5	2.5
Product Weight	1.45 lb (0.66 kg)	2.95 lb (1.33 kg)	1.6 lb (0.72 kg)



Heavy duty Erickson® collet ensures maximum strength and life

Accessories

- **Note:** Use 1/4" shank machined mandrel (599021 - 599024) for mounting cut-off wheels with 3/8" holes



For maximum performance we recommend 90 PSI air pressure.



ANGLE GRINDERS



402304



402305

Angle Grinders

- An excellent standard duty angle grinder
- Lightweight and compact design
- Self-locking lever throttle prevents accidental start-ups
- Ideally suited to the automotive aftermarket and medium duty industrial markets such as the M.R.O. and machine shop industries

Standard Accessories: side handle, guard, wrenches, grinding wheel, 5/8" - 11 NC adapter

PROD. NO. MOD. NO.	402304 AG40L	402305 AG50L
Wheel Diameter	4"	5"
Spindle Thread	10 mm x 1.25" *	10 mm x 1.25" *
Free Speed (RPM)	11,000	11,000
Avg. Air Consumption (cfm)	6	6
Min. Hose size	3/8"	3/8"
Air Inlet (NPT)	1/4"	1/4"
Sound Pressure (dBA)	91	91
Vibration (m/s ²)	0.7	0.7
Overall Length	8-3/4"	8-3/4"
Product Weight	4 lb (1.8 kg)	4.3 lb (1.94 kg)

* Note: Both grinders come with 10 mm x 1.25" spindle shafts. However, included in each box is an adapter to convert these units to a 5/8" - 11 NC thread if desired.

5" Angle Grinder - Heavy Duty

402313 / AG50HD

- Hardworking, compact .7 horsepower grinder designed for professional use
- Spindle lock for easy accessory changes
- Adjustable swivel guard has 9 positive lock settings, no tools required
- Composite housing and insulated side handle for operator comfort and control
- Rear exhaust directs air away from workplace
- Low noise, only 83 dBA
- Safety toggle on throttle lever prevents accidental start-ups
- Spindle backing plate and wheel nut suitable for use on all cut-off (T1) and grinding (T27) wheels up to 1/4" thickness

Standard Accessories: Side handle, guard, wrench

Optional Accessories: Anti-vibration handle (905781), quick nut (905782)



905782



905781

5" Angle Grinder - Super Heavy Duty

402312 / AG50SD

- Powerful .9 horsepower angle grinder for heavy duty applications
- Lightweight and compact design with new moulded handle grip
- Upgraded gear design offers up to twice the life of previous models
- Positive lock push-button throttle prevents accidental start-ups
- 5/8" - 11 NC threaded shaft for use with all popular North American accessories
- Spring loaded side exhaust valve is only open during open throttle operations cutting exhaust noise and preventing foreign matter from entering into the tool
- 360° swivel exhaust mechanism allows operator to choose direction of exhausted air
- Equipped with convenient side handle for maximum operator control
- Grease port for easy and convenient maintenance of gears
- Heavy duty wheel guard
- Air inlet screen filters air line debris, extending motor life

Standard Accessories: Side handle, guard, wrenches

Optional Accessory: Backing plate for use with cut-off wheels up to 1/8" (905318)

Upgraded gear design for longer life



402312



905318

Our most powerful 5" air angle grinder

For maximum performance we recommend 90 PSI air pressure.



PROD. NO. MOD. NO.	402313 AG50HD	402312 AG50SD
Wheel Diameter	5"	5"
Spindle Thread	5/8" - 11 NC	5/8" - 11 NC
Free Speed (RPM)	11,000	11,000
Avg. Air Consumption (cfm)	4	30
Min. Hose size	3/8"	3/8"
Air Inlet (NPT)	1/4"	1/4"
Sound Pressure (dBA)	83	91
Vibration (m/s ²)	2.4	0.6
Horsepower	.7	.9
Overall Length	9-1/2"	9-11/16"
Product Weight	4.4 lb (1.98 kg)	3.1 lb (1.4 kg)



ANGLE GRINDERS



905781



905319

Upgraded gear design for longer life



905319

7" Angle Grinder with Anti-Vibe Handle - Heavy Duty

402333 / AG70HD

- Powerful 1 horsepower angle grinder designed for the professional user
- Handy spindle lock for easy accessory changes
- Insulated rear handle and anti-vibration side handle for increased operator comfort and safety
- Safety release button on lever throttle prevents accidental start-ups
- Front exhaust outlet directs air away from the operator
- Exhaust outlet equipped with diffuser/muffler for quieter work place
- Spindle backing plate and wheel nut suitable for use on T27 wheels from 1/8" to 1/4" thickness

Standard Accessories: Anti-vibration side handle (905781), guard, hex wrench

Optional Accessories: Backing plate and wheel nut for thin wheels (905319)

7" Angle Grinder - Super Heavy Duty

402332 / AG70SD

- Powerful 1.2 horsepower angle grinder for heavy duty applications
- Lightweight and compact design with new moulded handle grip
- Upgraded gear design offers up to twice the life of previous models
- Positive lock push-button throttle prevents accidental start-ups
- 5/8" - 11 NC threaded shaft for use with all popular North American accessories
- Spring loaded side exhaust valve is only open during open throttle operations, cutting exhaust noise and preventing foreign matter from entering into the tool
- 360° swivel exhaust mechanism allows operator to choose direction of exhausted air
- Equipped with convenient side handle for maximum operator control
- Grease port for easy and convenient maintenance of gears
- Heavy duty wheel guard
- Air inlet screen filters air line debris, extending motor life

Standard Accessories: Side handle, guard, wrenches

Optional Accessory: Backing plate for use with cutting off wheels (905319)

Note: Optional backing plate is not for use on grinding operations



PROD. NO. MOD. NO.	402333 AG70HD	402332 AG70SD
Wheel Diameter	7"	7"
Spindle Thread	5/8" - 11 NC	5/8" - 11 NC
Free Speed (RPM)	7,000	7,800
Avg. Air Consumption (cfm)	6	45
Min. Hose Size	3/8"	1/2"
Air Inlet (NPT)	1/4"	3/8"
Sound Pressure (dBA)	102	97
Vibration (m/s ²)	.52	.6
Horsepower	1	1.2
Overall Length	13-3/4"	13-13/16"
Product Weight	7.7 lb (3.47 kg)	6.4 lb (2.88 kg)

- Lever throttle for ease of operation
- Air inlet screen filters air line debris, extending motor life

3" 90° Angle Head Cut-Off Tool - Heavy Duty

409012 / CO390HD

- Powerful .6 horsepower motor
- Rear exhaust, compact motor housing
- Unique design to gain access in hard to reach places
- Grease port for easy and convenient maintenance of gears
- Outstanding power, performance, durability and life
- Ideal for professional automotive and industrial applications

3" Cut-Off Tool - Heavy Duty

409015 / CO3HD

- Powerful .6 horsepower motor
- Rear exhaust, compact motor housing
- Insulating vinyl cover for operator comfort and safety
- Outstanding power, performance, durability and life
- Premium motor cylinder and 6 vane motor design for improved performance and life
- Ideal for professional automotive and industrial applications

PROD. NO. MOD. NO.	409012 CO390HD	409015 CO3HD
Free Speed (RPM)	18,000	20,000
Avg. Air Consumption (cfm)	5	4.5
Min. Hose Size	3/8"	3/8"
Air Inlet (NPT)	1/4"	1/4"
Overall Length	7-5/16"	7"
Disc Arbor Size	3/8"	3/8"
Horsepower	.6	.6
Cutting Wheel Size	3"	3"
Sound Pressure dBA	3	98
Product Weight	2.42 lb (1.10 kg)	1.75 lb (0.79 kg)



Heavy duty wheel guard, can easily adjust to direct debris from the operator.

Insulating vinyl cover for operator comfort and safety

Motor shaft features ball bearings front and back, and motor end plates are made from durable die cast aluminum metal for maximum life and performance



.6 horsepower

For maximum performance we recommend 90 PSI air pressure.



CUT-OFF TOOLS



3" Cut-Off Tool - Reversible - Heavy Duty

409014 / CO3DHR

- Powerful, industry leading .85 horsepower motor
- Unique reversible design allows operator to direct sparks away from themselves and sensitive areas for improved safety, control and convenience
- Lightweight composite body design offers maximum operator comfort and control
- Composite tools do not run "cold" like aluminum body tools
- Rear exhaust
- Lever throttle for ease of operation
- Air inlet screen filters air line debris, extending motor life
- 3/8" mandrel fits common sizes of cut-off discs
- Ideal for all professional automotive and industrial applications requiring maximum power and reversible capabilities



4" Cut-Off Tool - 6" Extended - Heavy Duty

409016 / CO4HDE

- Powerful .7 horsepower motor for professional use
- Push button, 8 position adjustable swivel blade guard rotates 126° – no tools required to change positions
- Extra long 6" extended neck allows access to many difficult areas and two hand operation for maximum control and flexibility
- Built-in convenient adjustable air regulator on top of tool
- Comfortable rubber molded cushion grip design
- Rear exhaust
- Lever throttle for ease of operation
- Air inlet screen filters air line debris, extending motor life
- 3/8" mandrel fits common sizes of cut-off discs
- Uses up to 4" cut-off wheels
- Ideal for professional automotive and industrial applications requiring a long reach cut-off tool



PROD. NO. MOD. NO.	409014 CO3DHR	409016 CO4HDE
Free Speed (RPM)	20,000	17,000
Avg. Air Consumption (cfm)	4	4
Min. Hose Size	3/8"	3/8"
Air Inlet (NPT)	1/4"	1/4"
Overall Length	6-3/4"	15-3/4"
Disc Arbor Size	3/8"	3/8"
Horsepower	.85	.7
Cutting Wheel Size	3"	4"
Sound Pressure dBA	85	84
Product Weight	2 lb (0.9 kg)	3.7 lb (1.67 kg)



**SHEET METAL TOOLS,
FASTENER TOOLS &
AUTOMOTIVE
SPECIALTY**

495



905461



905471

NIBBLER/SHEAR

Nibbler - Up Stroke Type - Heavy Duty

404153 / AN16

- Powerful .4 horsepower air motor for professional use
- Cuts on the up stroke for reduced punch breakage
- Small diameter cutting head permits nibbler to be started away from the edge of a work piece by drilling a 9/16" hole
- Position of the cutting head can be set to allow cutting in four directions, forward, reverse, right or left
- Nibbler cuts maximum steel thickness: Regular Steel 1.2 mm, Aluminum 1.6 mm, Stainless Steel 0.8 mm
- Compact design for use in close quarters

Standard Accessory: Punch (905461)

Pistol Grip Air Shear - Heavy Duty

404163 / PAS18

- Professional air shear for heavy duty applications
- Features a two gear, heavy duty planetary system for increased torque
- Popular pistol grip design for ease of operation
- Handle exhaust directs exhaust air away from the work piece and the operator
- Ideal for shearing steel, aluminum and most types of plastic
- Shear cuts maximum steel thickness: Regular Steel, Aluminum, Stainless Steel 1.24 mm
- Keep blades sharp for extended service life

Standard Accessory: Centre Blade (905471)

PROD. NO. MOD. NO.	404153 AN16	404163 PAS18
Strokes per Minute	3,000	2,200
Capacity of Steel (gauge)	17	18
Capacity of Steel (inch)	.054	.047
Capacity of Aluminum (gauge)	13	13
Capacity of Aluminum (inch)	.072	.072
Horsepower	.4	.35
Overall Length	7"	9-1/4"
Avg. Air Consumption (cfm)	7	4
Min. Hose Size	3/8"	3/8"
Air Inlet (NPT)	1/4"	1/4"
Sound Pressure (dBA)	85.5	85.1
Vibration (m/s ²)	3.8	2.5
Product Weight	2.1 lb (0.95 kg)	2.9 lb (1.31 kg)

SHEET METAL TOOL ACCESSORIES

PROD. NO.	Description
905461	Punch for 404153 (AN16) Nibbler
905471	Center Blade For 404163 (PAS18)

Reciprocating Saw 409141 / ARS112

- The ideal tool for the many cutting and filing applications that are found in automotive and industrial trades
- Features a rubber cover on the housing for operator comfort
- Equipped with an air whip complete with muffling exhaust hose to keep the work area clean and quiet
- Paddle throttle with safety toggle to prevent accidental starts

Standard Accessories: 3 pcs of 24 tooth bi-metal saw blades (905452), 5 assorted files (905451), air whip with muffling exhaust hose

Optional Accessories: 3 pcs of 32 tooth bi-metal saw blades (905453)

Strokes per Minute	5,500
Capacity of Steel (gauge)	9
Capacity of Steel (inch)	0.114
Capacity of Aluminum (gauge)	9
Capacity of Aluminum (inch)	0.114
Avg. Air Consumption (cfm)	7
Min. Hose Size	3/8"
Air Inlet (NPT)	1/4"
Sound Pressure (dBA)	73.9
Vibration (m/s ²)	6.6
Product Weight	2.87 lb (1.29 kg)



AIR SAW ACCESSORIES

Blades for 409141 (ARS112)

PROD. NO.	Description
905451	5 PC Assorted File Set
905452	3 PC 24 Tooth Bi-Metal Saw Blades
905453	3 PC 32 Tooth Bi-Metal Saw Blades



905451



905452



905453

For maximum performance we recommend 90 PSI air pressure.



AIR RIVET GUNS



409005



409009

3/16" Air Riveter - Heavy Duty

409005 / AR316HDA

- Powerful pulling load of 1,940 lb
- Can be used on all rivet material types, including steel and aluminum, up to 3/16"
- 9/16" stroke sets rivets in one hit, increasing efficiency
- Very compact and lightweight – only 3.2 lb
- Includes 4 sizes of nose pieces for a wide range of uses
- High quality, see-through collection bottle
- Air relief valve prevents overloading for greater tool service life
- Designed for professional automotive and light to medium duty industrial applications

NEW

1/4" Air Riveter - Heavy Duty

409009 / AR14HDA

- Powerful pulling load of 2,248 lb
- Can be used on all rivet material types, including steel and aluminum, up to 1/4"
- Longer 20 mm stroke sets rivets in one hit, increasing efficiency
- Compact and lightweight – only 2.42 lb
- Tough composite outer shell for maximum toughness, protection and longevity
- Includes 4 sizes of nose pieces for a wide range of uses
- High quality collection bottle with screw on attachment for ease of operation
- Designed for professional automotive and light to medium duty industrial applications

NEW

PROD. NO. MOD. NO.	409005 AR316HDA	409009 AR14HDA
Rivet Capacity	3/16"	1/4"
Pull Force (lb)	1,940	2,248
Stroke	0.56" (14 mm)	.81" (20.6 mm)
Avg. Air Consumption (cfm)	4	4.5
Min. Hose Size	3/8"	3/8"
Air Inlet (NPT)	1/4"	1/4"
Nosepiece	3/32" (2.4 mm) 1/8" (3.2 mm) 5/32" (4.0 mm) 3/16" (4.8 mm)	1/8" (3.2 mm) 5/32" (4.0 mm) 3/16" (4.8 mm) 1/4" (6.4 mm)
Vibration (m/s ²)	2.5	2.5
Sound Pressure (dBA)	75	75
Product Weight	3.3 lb (1.49 kg)	2.4 lb (1.1 kg)

- Specific components manufactured with high cost, super precise CNC deep hole drilling processes for extreme accuracy and tolerance
- Integrated vacuum/exhaust system with a convenient adjustable switch allows operator to adjust mandrel retention and collection
- Designed with integrated spring and air return system for fast, reliable cycles
- Japanese NOK rubber gasket for longest tool life
- Specially designed "quick opening" collection bottle eliminates the need to remove bottle when emptying
- Designed for production and heavy duty power riveting applications

3/16" Air Riveter - Super Heavy Duty

409007 / AR316SD

- New production quality air riveter delivers a powerful pulling load of 2,600 lb
- Can be used on aluminum, steel and stainless steel rivets up to 3/16"
- Longer 20mm stroke sets rivets in one hit, increasing efficiency
- Includes 4 sizes of nose pieces for a wide range of uses



409007

Swivel Connector

1/4" Air Riveter - Super Heavy Duty

409008 / AR14SD

- New production quality air riveter delivers a powerful pulling load of 3,520 lb
- Can be used on aluminum, steel and stainless steel rivets up to 1/4"
- Can also be used on 3/16" and 1/4" monobolts
- Longer 26mm stroke sets rivets in one hit, increasing efficiency
- Includes 3 sizes of nose pieces for a wide range of uses



409008

Swivel Connector

PROD. NO. MOD. NO.	409007 AR316SD	409008 AR14SD
Rivet Capacity	3/16"	1/4"
Pull Force (lb)	2,600	3,520
Stroke	0.78" (20mm)	1.02" (26mm)
Avg. Air Consumption (cfm)	5.5	10.1
Min. Hose Size	3/8"	3/8"
Air Inlet (NPT)	1/4"	1/4"
Nosepiece	3/32" (2.4mm)	5/32" (4.0mm)
	1/8" (3.2mm)	3/16" (4.8mm)
	5/32" (4.0mm)	1/4" (6.4mm)
	3/16" (4.8mm)	
Vibration (m/s ²)	2.5	2.5
Sound Pressure (dBA)	75	75
Product Weight	3.3 lb (1.49 kg)	3.3 lb (1.49 kg)

For maximum performance we recommend 90 PSI air pressure.



409042



905491



905492



905493



905494

PISTOL GRIP SCREWDRIVER

1/4" Hex Pistol Grip Screwdriver

404606 / PSD14H

- Reversible screwdriver with internally adjusted clutch
- Three interchangeable clutch springs for maximum variety of torque settings
- Pistol grip design with handle exhaust outlet for operator comfort
- Quick release 1/4" hex bit holder
- Variable torque settings make this tool ideal for use in all industrial applications

Standard Accessories: 3 clutch springs (905761), 2 wrenches

FASTENER TOOL ACCESSORIES

3 Clutch Springs for 404606 (PSD14H)

905761

- Green Spring Torque Rating: **35.40 in/lb (4Nm) to 79.66 in/lb (9Nm)**
- Black Spring Torque Rating: **44.25 in/lb (5Nm) to 115 in/lb (13Nm)**
- Yellow Spring Torque Rating: **26.55 in/lb (3Nm) to 53.10 in/lb (6Nm)**

Air Scraper Kit

409042 / ASK6

- Put the power of compressed air to work on all your scraping jobs
- The ideal tool for fast removal of baked on gasket material, paint and unwanted deposits
- Lightweight and compact
- Complete with four different scraper blades for maximum versatility
- Handy blow mould case for storage
- Includes air regulator for exact power adjustment

Standard Accessories: Blow mould case, hex wrench, air regulator (408811), 1" straight cut, flat scraper blade 1", 1-3/4" straight cut, flat scraper blade, 1-3/4" straight cut, angle scraper blade

PROD. NO MOD. NO.	404606 PSD14H	PROD. NO MOD. NO.	409042 ASK6
Chuck Capacity	1/4" Hex	Strokes per Minute	4,800
Torque Rating (in/lb)	20 - 115	Piston Diameter	1/2"
Reversible	Oui	Piston Stroke	5/8"
Horsepower	.35	Avg. Air Consumption (cfm)	4
Free Speed (RPM)	1,800	Min. Hose Size	3/8"
Overall Length	8-1/2"	Air Inlet (NPT)	1/4"
Avg. Air Consumption (cfm)	4	Overall length	9-1/2"
Min. Hose Size	3/8"	Product Weight	1.6 lb (0.72 kg)
Air Inlet (NPT)	1/4"		
Product Weight	2.7 lb (1.22 kg)		

AIR SCRAPER ACCESSORIES

PROD. NO.	Description	PROD. NO.	Description
905491	1" Straight Cut, Flat Scraper	905493	1" Diagonal Flat Scraper
905492	1-3/4" Straight Flat Scraper	905494	1-3/4" Straight Angle Scraper

AIR DRILLS



PISTOL GRIP DRILLS

3/8" Reversible Drill - Keyed Chuck

404415 / ADX380R



- Hardened steel planetary gears for long life performance
- Excellent power-to-weight ratio
- Forward / reverse switch conveniently located for single handed operation
- Contoured handle design and aluminum die cast throttle offer precise operator control
- Excellent for a wide range of drilling jobs

Standard Accessory: 3/8" keyed chuck (905755)

Optional Accessory: 3/8" keyless chuck (905753)



3/8" Reversible Drill - Keyed Chuck - Heavy Duty

404412 / ADR380HD

- Designed for heavy duty use this powerful yet compact air drill features a heat treated cylinder, two steel motor bearing plates, black oxide finished rotor and full cage planetary gear mechanism for maximum service life
- Reverse switch situated for fast and easy single handed operation
- Complete with black rubber insulating grip for operator comfort and safety (905751)
- Pressure grease fitting on housing permits easy maintenance for longer tool life
- Air inlet screen prevents solid matter from entering the tool for extended tool life
- Excellent for a wide range of drilling jobs

Standard Accessory: 3/8" keyed chuck (905755)

Optional Accessory: 3/8" keyless chuck (905753)



3/8" Reversible Drill - Keyless Chuck - Heavy Duty

404419 / AD380HDR

- Designed for heavy duty use this powerful yet compact air drill features a heat treated cylinder, two steel motor bearing plates, black oxide finished rotor and full cage planetary gear mechanism for maximum service life
- Reverse switch situated for fast and easy single handed operation
- Complete with black rubber insulating grip for operator comfort and safety (905751)
- Pressure grease fitting on housing permits easy maintenance for longer tool life
- Air inlet screen prevents solid matter from entering the tool for extended tool life
- Excellent for a wide range of drilling jobs

Standard Accessory: 3/8" keyless chuck (905753)

Optional Accessory: 3/8" keyed chuck (905755)



PROD. NO. MOD. NO.	404412 ADR380HD	404419 AD380HDR
Horsepower	.5	.5
Free Speed (RPM)	1,800	1,800
Overall Length	7-1/2"	7-1/2"
Avg. Air Consumption (cfm)	4	4
Min. Hose Size	3/8"	3/8"
Air Inlet (NPT)	1/4"	1/4"
Chuck Capacity	3/8"	3/8"
Reversible	Yes	Yes
Spindle Size	3/8" - 24	3/8" - 24
Sound Pressure (dBA)	86	86.8
Vibration (M/S ²)	2.5	2.5
Product Weight	1.41 lb (0.63 kg)	2.7 lb (1.22 kg)



PISTOL GRIP DRILLS



1/2" Drill - Keyed Chuck

404423 / RDX12

- Double reduction planetary gear system gives low speed and high torque for heavier drilling jobs
- Ball and needle bearing construction
- Auxiliary side handle included
- This 500 RPM 1/2" air drill is designed for heavier steel plate drilling, cylinder honing and all jobs requiring high torque

Standard Accessory: 1/2" keyed chuck (905756)

Optional Accessory: 1/2" keyless chuck (905754)



1/2" Reversible Drill - Keyless Chuck - Heavy Duty

404424 / AD12HDR

- Heavy duty motor with double reduction planetary gear system to 800 RPM provides exceptional power
- Reverse switch situated for fast and easy one handed operation
- Side handle provides maximum operator control and absorbs stall torque reaction for operator safety
- Complete with black rubber insulating grip for operator comfort and safety (905752)
- Ball and needle bearing construction
- Air inlet screen prevents solid matter from entering the tool, extends tool life

Standard Accessory: 1/2" keyless chuck (905754)

Optional Accessory: 1/2" keyed chuck (905756)



1/2" Reversible Drill - Keyed Chuck - Heavy Duty

404422 / ADR12HD

- Same qualities as 404424 but comes standard with keyed chuck (905756)

Optional Accessory: 1/2" keyless chuck (905754)

PROD. NO. MOD. NO.	404423 RDX12	404424 AD12HDR	404422 ADR12HD
Horsepower	.4	.4	.4
Free Speed (RPM)	500	800	800
Overall Length	9-3/4"	9-1/2"	9-1/2"
Avg. Air Consumption (cfm)	3	4	4
Min. Hose Size	3/8"	3/8"	3/8"
Air Inlet (NPT)	1/4"	1/4"	1/4"
Chuck Capacity	1/2"	1/2"	1/2"
Reversible	No	Yes	Yes
Spindle Size	3/8" - 24	3/8" - 24	3/8" - 24
Sound Pressure (dBA)	87.7	83.3	83.3
Vibration (m/s ²)	2.5	2.5	2.5
Product Weight	3.74 lb (1.68 kg)	4.8 lb (2.16 kg)	4.8 lb (2.16 kg)

3/8" Reversible Angle Head Drill - Heavy Duty

404418 / AD38AHR

- Exceptionally low profile 90° angle head design makes this drill ideal for working in confined areas
- Reverse valve for improved efficiency
- Lubrication port on the gear head permits convenient preventative maintenance resulting in extended tool life
- Rear exhaust outlet directs exhausted air away from the workplace for operator comfort and safety
- Teasing throttle delivers improved control from start up through run down
- Specifically designed for corner drilling, holesaw use, auto body work and other general applications

Chuck Capacity	3/8"
Reversible	Yes
Horsepower	.33
Spindle Size	3/8" - 24
Free Speed (RPM)	1,700
Overall Length	8-1/4"
Avg. Air Consumption (cfm)	4
Min Hose Size	3/8"
Air Inlet (NPT)	1/4"
Product Weight	2.42 lb (1.09 kg)



Features
Jacobs® Chuck

For maximum performance we recommend
90 PSI air pressure.

AIR DRILL ACCESSORIES

Keyless Chucks

PROD. NO.	Size
905753	3/8"
905754	1/2"



905753

Keyed Chucks

PROD. NO.	Size
905755	3/8"
905756	1/2"



905755 - 905756

Protective Handle Covers

PROD. NO.	Description
905752	Black Rubber Handle Cover for 404424 (AD12HDR)
905751	Black Rubber Handle Cover for 404419 (AD380HDR)



905751



DRILL BITS

JET carries four series of premium drill bits, each offering its own unique features and advantages.

We begin with our general purpose JET-KUT® H.S.S. 135° split point bits which offer good drilling characteristics at an economical price and work our way up to our JET-KUT® B & G, JET-KUT® Gold and the ultimate bit, JET-KUT® Cobalt.

Both the JET-KUT® B & G and JET-KUT® Gold feature premium M2 high speed steel materials, 135° split points, and three ground flats on the shaft to eliminate chuck slippage. The B & G series is quickly becoming an industry favourite offering outstanding drilling performance at very competitive prices.

If you are looking for true drilling performance and more holes per bit, look no further. JET has the right drilling solution for your application.



BEST

JET-KUT® Cobalt
570144



BEST

JET-KUT® Gold
570142



**
BETTER

JET-KUT® B+G SERIES
570146



*
GOOD

JET-KUT®
570108

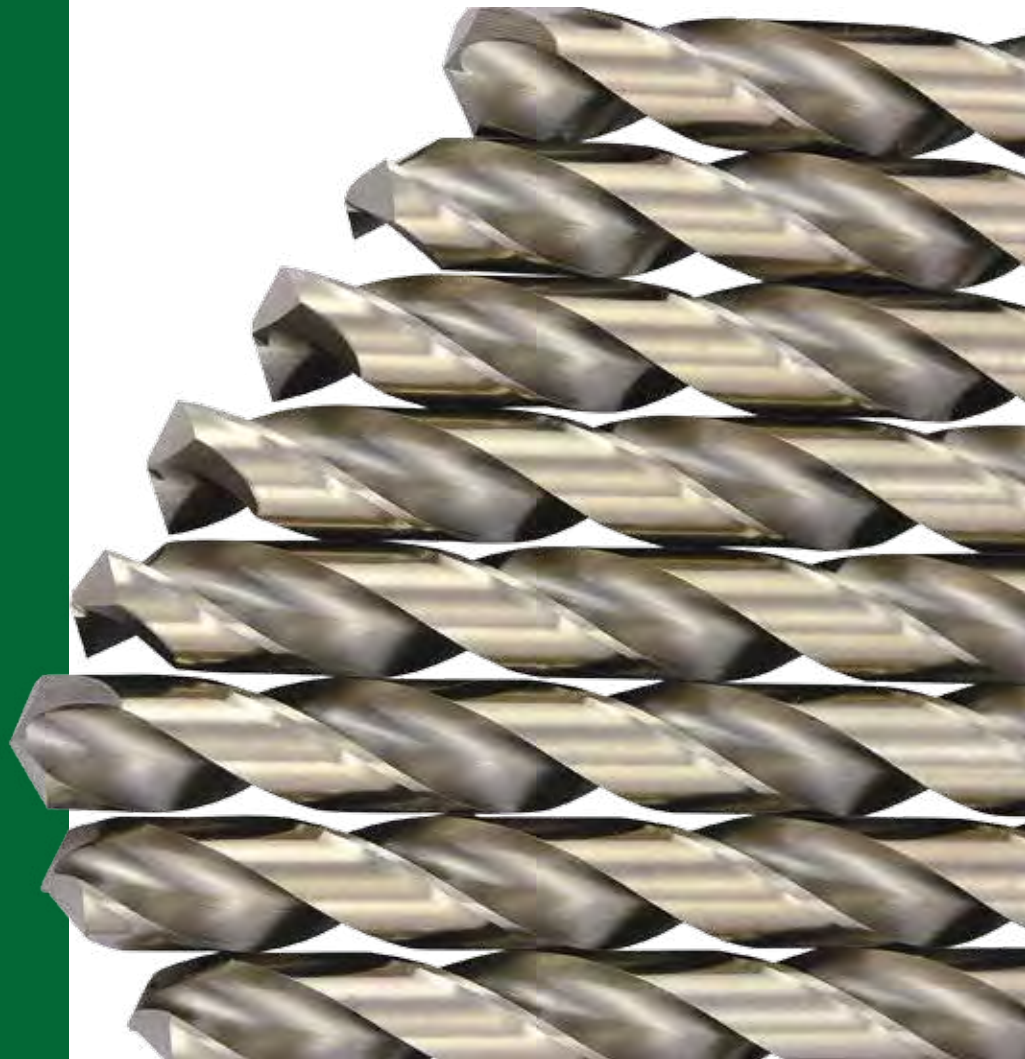



AIR HAMMERS



507



.401 SHANK AIR HAMMERS



.401 Shank Medium Barrel Air Hammer

404123 / AH150M

- Medium barrel delivers steady powerful blows
- Accepts popular .401 taper shank chisels
- Standard quick change spring safety retainer
- Polished aluminum one-piece housing and handle with heat treated alloy steel barrel and piston for long life
- Built-in steel air regulator
- A popular choice for muffler and pipe removal, body shop work, shock work and many other automotive applications

Standard Accessory: Standard spring retainer (905146)

Optional Accessory: Quick coupler retainer (408291)



.401 Shank Long Barrel Air Hammer

404124 / AH150L

- Long barrel design for more hammering power
- Accepts popular .401 taper shank chisels
- Standard quick change spring safety retainer
- Polished aluminum one-piece housing and handle with hardened steel barrel and piston for long life
- Built-in steel air regulator
- Ideal for air hammering applications which require increased power

Standard Accessory: Standard spring retainer (905146)

Optional Accessory: Quick coupler retainer (408291)

PROD. NO. MOD. NO.	404123 AH150M	404124 AH150L
Blows per Minute	3,500	2,000
Piston Diameter	11/16"	3/4"
Piston Stroke	2-5/8"	3-1/2"
Overall Length	6-3/4"	10-1/4"
Avg. Air Consumption (cfm)	4	4.2
Min. Hose Size	3/8"	3/8"
Air Inlet (NPT)	1/4"	1/4"
Sound Pressure (dBA)	99.2	98.7
Vibration (m/s ²)	7.4	14.5
Product Weight	3.5 lb (1.58 kg)	4.4 lb (1.98 kg)

.401 SHANK AIR HAMMERS



6 PC Air Hammer Kit - Super Heavy Duty

404126 / AH150SD

- Super Heavy Duty .401 shank, long barrel air hammer
- "Shock Vibration Reduction" technology ensures operator comfort, safety and prevents potential physical damage
- Hits harder with less effort
- Designed with an ergonomic "T" handle grip for balance and comfort
- Developed for demanding use such as: exhaust systems, front end work, bushing driving, cutting, general repairs and heavy production work
- Equipped with heavy duty quick coupler retainer for quick bit changes
- Complete with 5 bits in a blow mould case

Kit includes:

- Air Hammer 404126 (AH150SD), quick coupler retainer (408291), 1" O.D. Hammer, Panel Cutter, Narrow Face Chisel, Wide Face Chisel, Tapered Punch



Blows per Minute	2,000
Piston Diameter	3/4"
Piston Stroke	3-1/2"
Overall Length	10-1/2"
Avg. Air Consumption (cfm)	2.77
Min. Hose Size	3/8"
Air Inlet (NPT)	1/4"
Sound Pressure (dBA)	101.7
Vibration (m/s ²)	5.75
Product Weight	4.28 lb (1.93 kg)



.401 SHANK AIR HAMMERS

Accessories

.401 Retainers

PROD. NO.	Description	Fits
408291	Quick Coupler Retainer	
408292	Standard Spring Retainer - Carded	404123 (AH150M) 404124 (AH150L)
905146	Standard Spring Retainer - Bulk	404126 (AH150SD) 409131 (RH954)
905852	Beehive Retainer	
905861	Standard Spring Retainer for .498 Steel Bits	409132 (RH955)
905862	Beehive Spring Retainer for .498 Steel Bit	
PUT-QCR401-INSERT	Plastic Insert	-
PUT-QCR401-SC	Set Screw - Set of 3	-

Includes five popular .401 shank air chisels





.401 SHANK AIR HAMMERS

Accessories

- .401 shank diameter
- A premium grade air hammer chisel for professional applications
- Made from superior grade Chrome-Molybdenum 4140 steel
- Ideal for use with regular and heavy duty air hammers
- Specially heat treated for maximum strength and performance
- Sand-blasted and Zinc-Phosphated to prevent rust
- Available in open stock and 4 and 8 piece sets

.401 Shank 4 PC Hammer Steel Set - Heavy Duty 408281 / PACS-4

- Includes: **408221, 408223, 408225** and **408227** in terylene pouch



.401 Shank 8 PC Hammer Steel Set - Heavy Duty 408283 / PACS-8

- Includes: **408221, 408222, 408223, 408224, 408225, 408226, 408227** and **408228** in terylene pouch



.401 Air Hammer Steel - Heavy Duty - Open Stock

PROD. NO.	Shank Size	Overall Length	Type
408221	.401	7"	Tapered Punch
408222	.401	7"	1-3/8" Cold Chisel
408223	.401	7"	13/16" Cold Chisel
408224	.401	7"	Ripping & Cut-off Chisel
408225	.401	7"	Spot Weld Buster
408226	.401	7"	Single Blade Panel Cutter
408227	.401	7"	Deluxe Panel Cutter
408228	.401	8"	Muffler & Tailpipe Cutter Remover
408231	.401	4"	Air Hammer
408232	.401	7"	15/16" x 7" Ball Joint Separator



.401 Air Hammer Steel - Open Stock

- Fits 404123 (AH150M), 404124 (AH150L), 404126 (AH150SD), 409113 (RH954) and other .401 hammers

PROD. NO.	MOD. NO.	Shank Size	Overall Length	Type
408201	810	.401	8-3/4"	Flat Chisel
408202	807	.401	6-3/8"	Sheet Metal Cutter
408207	812	.401	7"	Taper Punch
408213	805	.401	6-1/4"	Wide Chisel
408214	823	.401	7-1/8"	Paint Scraper



.401 Shank Riveting Hammer - Heavy Duty

409131 / RH954

- Compact and powerful, provides the hard hitting blows required to drive 1/8 - 3/8" steel rivets used in industrial assembly applications
- Ideal for a wide variety of hammering, chipping, cutting and scraping applications
- Uses standard .401 shank steels
- Teasing throttle for maximum control
- Muffled side outlet exhaust for quieter and cleaner operations

Standard Accessory: Bee-hive retainer (905852)

Optional Accessories: Standard spring retainer (905146), Quick coupler retainer (408291)

NOTE: See page 509 for .401 shank accessories



.498 Shank Riveting Hammer - Heavy Duty

409132 / RH955

- Powerful air hammer, provides the slow, steady blows required to drive 1/4 - 3/8" steel rivets used in industrial assembly applications
- Ideal for a wide variety of hammering, chipping, cutting and scraping applications
- Uses popular .498 shank steels
- Teasing throttle for maximum control
- Muffled side outlet exhaust for quieter and cleaner operations

Standard Accessories: Bee-hive retainer (905862)

Optional Accessories: Standard spring retainer (905861)



PROD. NO. MOD. NO.	409131 RH954	409132 RH955
Blows per Minute	1,740	1,560
Piston Diameter	1/2"	3/4"
Piston Stroke	3-1/16"	2-11/16"
Avg. Air Consumption (cfm)	12	16
Min. Hose size	3/8"	3/8"
Air Inlet (NPT)	1/4"	1/4"
Sound Pressure (dBA)	97	95
Vibration (m/s ²)	28.8	12.5
Overall Length	7-5/8"	8"
Product Weight	3 lb (1.35 kg)	4.9 lb (2.21 kg)



905861



905862

For maximum performance we recommend 90 PSI air pressure.



FLUX CHIPPERS/NEEDLE SCALERS



Straight Type Flux Chipper - Heavy Duty

404203 / FC250

- A powerful heavy duty industrial flux chipper
- Light-weight compact design allows maximum operator control and access to jobs in hard-to-reach areas
- Lever throttle control
- Easy to use ball-type chisel retainer allows quick, easy bit changes
- Can be converted into needle scaler
- Ideal for all chipping operations including removal of slag, scale, welds and masonry

Standard Accessory: 1" wide angle chisel (408402)



Needle Scaler Attachment for 404213 - Heavy Duty

404213 / 250NS

- Excellent for paint, rust, dirt or weld scale removal from irregular and curved surfaces or hard-to-reach areas
- Designed to be used with Flux Chipper (404203)
- Needle length: 180mm, needle blade width: 3mm

Standard Accessories: Set of 19 needles (905742), wrench



Needle Scaler Kit - Heavy Duty

404208 / FC250NS

- Includes straight type flux chipper - Heavy Duty (404203) and needle scaler attachment (404213)
- A powerful heavy duty industrial needle scaler
- Light-weight design
- Lever throttle control
- Excellent for paint, rust, dirt or weld scale removal from irregular and curved surfaces or hard-to-reach areas

Standard Accessories: Set of 19 needles (905742), 1" wide angle chisel (408402), wrench

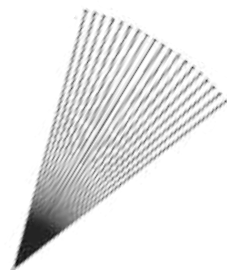

905742



408402

PROD. NO. MOD. NO.	404203 FC250	404208 FC250NS
Blows per Minute	4,500	4,500
Piston Diameter	1"	1"
Piston Stroke	7/8"	7/8"
Overall Length	8-1/2"	17-1/2"
Avg. Air Consumption (cfm)	14.1	14.1
Min. Hose size	1/2"	1.2"
Air Inlet (NPT)	1/4"	1/4"
Sound Pressure (dBA)	117	117
Vibration (m/s ²)	2.5	1.5
Product Weight	3.75 lb (1.69 kg)	6 lb (2.7 kg)

Straight Type Needle Scaler

404226 / NS260

- A reliable, well priced standard duty needle scaler
- Excellent for paint, rust, dirt or weld scale removal from irregular and curved surfaces or hard-to-reach areas
- Bayonet mount offers 3 quick change, power settings
- Lever throttle control
- Converts quickly to flux chipper with optional 404226 (NS260) steels

Standard Accessory: Set of 19 needles (905742)

Optional Accessories: Straight chisel (408406), angle chisel (408407)

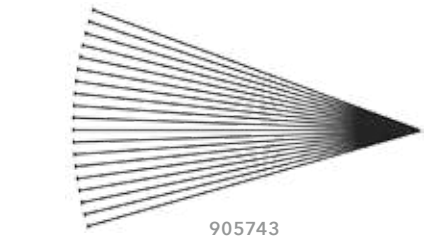

905743



Pistol Grip Type Needle Scaler

404228 / NS260P

- Excellent for paint, rust, dirt or weld scale removal from irregular and curved surfaces or hard-to-reach areas
- Ergonomic pistol grip design with insulated handle for operator comfort and control
- Compact 12-1/2" overall length
- Letterbox shaped needle opening permits work deep into narrow slots or on wide surfaces
- Lever throttle control

Standard Accessories: Set of 19 needles (905743), wrench

PROD. NO. MOD. NO.	404226 NS260	404228 NS260P
Blows per Minute	4,400	3,700
Piston Diameter	1"	0.93"
Piston Stroke	1-1/2"	3"
Overall Length	18"	12.5"
Avg. Air Consumption (cfm)	8.8	10
Min. Hose size	1/2"	1/2"
Air Inlet (NPT)	1/4"	1/4"
Sound Pressure (dBA)	92	97
Vibration (m/s ²)	10.2	8.7
Product Weight	6.2 lb (2.79 kg)	5.7 lb (2.57 kg)

FLUX CHIPPERS/NEEDLE SCALERS

Accessories

- JET corner notched flux chipper steels are available in three styles designed to fit most popular flux chippers and needle scalers such as **404203**
- JET flat notched flux chipper steels are available in three styles designed to fit **404226** and other flux chippers that use flat notched steels with round shank



Needles and Steels - Heavy duty

PROD. NO.	MOD. NO.	Blade Width	Overall Length	Type	Designed to Fit
408401	SC25	3/4"	6"	Straight Chisel	
408402	AC25	1"	6-1/4"	Angle Chisel	404203 (FC250)
408403	WC25	1-3/8"	6-1/4"	Wide Chisel	
408406	SC260	3/4"	7"	Straight Chisel	404226 (NS260)
408407	AC260	1-3/8"	7"	Angle Chisel	
905742		3mm	180mm	Set of 19 needles for 404213 (250NS) / 404208 (FC250NS)	Sold as each
905743		3mm	180mm	Set of 19 needles for 404226 (NS260), 404228 (NS260P)	Sold as each

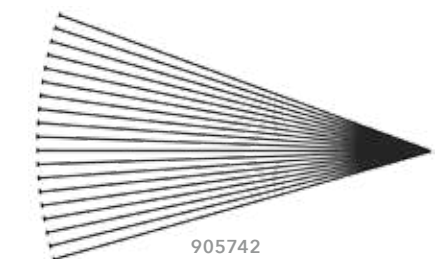

905742



CHIPPING HAMMERS



404323

Chipping Hammers - Heavy Duty

- This powerful and hard hitting tool offers the perfect balance of performance and life
- Available in two different stroke lengths and two popular shank styles
- Outside teasing throttle for safety and control
- Saw tooth handle to cylinder connection for durability

Standard Accessories: Standard retainer (404313), retainer spring (905842)

PROD. NO. MOD. NO.	404323 CH3H	404324 CH4H	404328 CH3R	404329 CH4R
Collar Type	.580 Hex	.580 Hex	.680 Rnd	.680 Rnd
Piston Dia. x Stroke	1-1/8" x 3	1-1/8" x 4	1-18" x 3	1-1/8" x 4
Blows per Minute	1,920	1,500	1,920	1,500
Overall Length	14-7/8"	16-1/8"	14-7/8"	16-1/8"
Avg. Air Con. (cfm)	25	28	25	28
Min. Hose Size	1/2"	1/2"	1/2"	1/2"
Air Inlet (NPT)	1/2"	3/8"	3/8"	3/8"
Product Weight	14 lb (6.3 kg)	15 lb (6.75 kg)	14 lb (6.3 kg)	15 lb (6.75 kg)

CHIPPING HAMMERS

Accessories

.580 Hex Shank Steel

- .580 Hex shank with oval collar fits 404323 (CH3H) and 404324 (CH4H) chipping hammers and all other makes of .580 hex shank oval collar chipping hammers

PROD. NO.	MOD. NO.	Description	Overall Length
408312	VF300H	Flat Chisel	12"
408331	VM230H	Moil Point	10"
408332	VM300H	Moil Point	12"
408352	VWF300H	Wide Flat Chisel	12"

.680 Round Shank Steel

- .680 Round shank with oval collar fits 404328 (CH3R) and 404329 (CH4R) chipping hammers and all other makes of .680 round shank oval collar chipping hammers

PROD. NO.	MOD. NO.	Description	Overall Length
408315	VF300R	Flat Chisel	12"
408335	VM300R	Moil Point	12"
408355	VWF300R	Wide Flat Chisel	12"

Retainer Springs

PROD. NO.	MOD. NO.	Description
404313	CHR-1	Standard Retainer
905802	JCO1191-2	Retainer Spring - Heavy Duty
905842	JCO194	Retainer Spring



408312



408331



408332



408352



408315



408335



408355



404313



905842



AIR SANDERS

515



MINI SANDERS



3" 90° Angle Head Sander - Heavy Duty

403095 / AS90HD

- Powerful .6 horsepower motor
- Rear exhaust, compact motor housing
- Premium motor cylinder and 6 vane motor design for improved performance and life
- Motor shaft features ball bearings front and back, and motor end plates are made from durable die cast aluminum metal for maximum life and performance
- Insulating vinyl cover for operator comfort and safety
- Lever throttle with roller tip for ease of operation
- Air inlet screen filters airline debris, extending motor life
- Grease port for easy and convenient maintenance of gears
- Outstanding power, performance, durability and life
- Ideal for professional automotive and industrial applications
- Includes a 3" turn-on style pad and a #80 and #100 grit disc
- Can use 2" or 3" back-up pads and abrasives



3" Mini Polisher Kit

403192 / MP75K

- Compact pistol grip sander for use in confined spaces
- Convenient, comfortable pistol grip design provides great operator control
- Direct drive mechanism has fewer moving parts, for maximum tool life
- Ergonomic handle with finger grips and insulating cover
- Variable speed, push button throttle
- Muffled handle exhaust directs air away from work piece

Standard Accessories: 3" hook and loop backing pad (502991), 3-1/2" bonnet (502995), 3-1/2" yellow compounding pad (502992), 3-1/2" white compounding pad (502993), wrench, blow mould case

PROD. NO. MOD. NO.	403095 AS90HD	403192 MP75K
Backing Pad Size	3"	3"
Free Speed (RPM)	15,000	2,500
Spindle	1/4"-20NC Male	1/4"-20NC Female
Horse Power	.6	.3
Avg. Air Consumption (cfm)	5	4
Min. Hose Size	3/8"	3/8"
Air Inlet (NPT)	1/4"	1/4"
Sound Pressure (dBA)	95	88
Vibration (m/s ²)	2	0.77
Product Weight	2.2 lb (1 kg)	3.25 lb (1.46 kg)
Overall Length	7-5/16"	5"

5" High Speed Sander

403102 / VS125A

- An excellent standard duty high speed sander
- Complete with 3", 4-1/2" and 5" backing plates
- Deluxe grip handle for comfortable operation
- Built-in power regulator
- Excellent for a variety of surface conditioning operations such as paint removal, light touch-up work, rust removal, etc.

Standard Accessories: 3" backing plate (905301), 4-1/2" backing plate (905302), and 5" backing plate (905303), holding tool (905304), nut (905305)



7" Verticle Sander

403112 / VS700C

- Double idler planetary gear system
- Ball bearing construction
- Built-in grease fitting for grease refill
- Light-weight and 2 handle design offers maximum operator control
- 4,500 RPM is ideal for rust removal and general sanding

Standard Accessories: 7" plastic pad (905306), 5/8"-11NC nut (905307), side handle, wrenches



PROD. NO. MOD. NO.	403102 VS125A	403112 VS700C
Backing Disc Size	3 - 5"	7"
Spindle	7/16" - 20	5/8"-11NC
Free Speed (RPM)	18,000	4,500
Avg. Air Consumption (cfm)	6	6
Min. Hose size	3/8"	3/8"
Air Inlet (NPT)	1/4"	1/4"
Product Weight	2.5 lb (1.13 kg)	5.5 lb (2.48 kg)
Sound Pressure	99.5	-
Vibration (m/s ²)	<2.5	-

**SANDERS
Accessories**

PROD. NO.	Size	Description
905301	3"	Backing Plate for 403102 (VS125A)
905302	4-1/2"	
905303	5"	
905304	-	Holding Tool for 403102 (VS125A)
905305	-	Adaptor Lock Down Nut for 403102 (VS125A)
905306	7"	Plastic Backing Pad for 403112 (VS700C)
905307	5/8" - 11NC	Mounting Nut for 403112 (VS700C)



905301



905305



905303



905307

For maximum performance we recommend 90 PSI air pressure

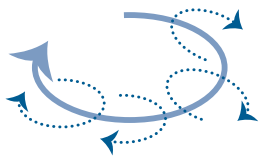

3/16" Orbital Diameter



Connects to dust collection system

RANDOM ORBITAL SANDERS

- Dual orbital action provides a swirl free finish
- Paddle throttle and vinyl lined top housing for operator comfort and control
- Heavy duty Magnalium Alloy cylinder, steel front end plate and heat treated throughout for extended service life
- Muffled, rear exhaust outlet directs exhaust air away from the work piece
- 6" x 120 gram +/-5, PSA type pad which is balance weighted to reduce vibration
- Adjustable speed regulator

6" Dual Action Random Orbit Non-Vac Sander - Heavy Duty

403212 / DA63NV

- Compact pistol grip sander for use in confined spaces
- Convenient, comfortable pistol grip design provides great operator control
- Direct drive mechanism has fewer moving parts, for maximum tool life
- Ergonomic handle with finger grips and insulating cover
- Variable speed, push button throttle
- Muffled handle exhaust directs air away from work piece

6" Dual Action Random Orbit Central-Vac Sander - Heavy Duty

403217 / DA63CV

- Designed and equipped for use with a central dust collection system for work place safety.

Standard Accessories: 6" PSA six hole sanding pad (905317), wrench

PROD. NO. MOD. NO.	403212 DA63NV	403217 DA63CV
Stroke (Orbit Dia.)	3/16"	3/16"
Spindle	5/16" - 24 NC	5/16" - 24 NC
Free Speed (RPM)	10,000	10,000
Avg. Air Consumption (cfm)	10	10
Min. Hose size	3/8"	3/8"
Air Inlet (NPT)	1/4"	1/4"
Product Weight	2.2 lb (0.99 kg)	2.3 lb (1.04 kg)
Overall Length	6-1/2"	8-1/4"

6" Dual Action Sander

403203 / FS127A

- 3/16" diameter stroke for swirl free finish
- Maximum 10,000 RPM is adjustable by use of built-in regulator
- Ball bearing construction for long life
- Dynamically balanced for minimum vibration
- Die-cast aluminum housing with black rubber cover for protection
- Ideal for feather edging, metal preparation and finish work on body filler
- Rated at 86 decibels

Standard Accessory: 6" sanding pad (905310)

Optional Accessory: 5" sanding pad (905313)

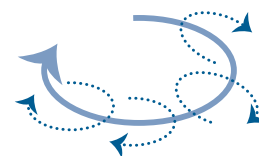

3/16" Orbital Diameter



6" Dual Action "Quiet" Random Orbit Sander - Heavy Duty

403201 / FS127Q

- Improved muffler design reduces noise level in the work place
- Dual sanding action for swirl free finish and fast stock removal, combines an 11/64" orbital stroke and 10,000 RPM free speed rotary action
- Design improvements for greater durability
- Ball bearing construction for long life
- Dynamically balanced for minimum vibration
- Throttle lock to prevent accidental start up
- Ideal for feather edging, metal preparation and finish work on body filler
- Rated at 83.8 decibels

Standard Accessory: 6" sanding pad (905310)

Optional Accessory: 5" sanding pad (905313)

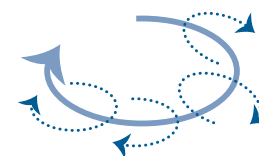

11/64" Orbital Diameter

PROD. NO. MOD. NO.	403102 VS125A	403112 VS700C
Backing Disc Size	3 - 5"	7"
Spindle	7/16" - 20	5/8"-11NC
Free Speed (RPM)	18,000	4,500
Avg. Air Consumption (cfm)	6	6
Min. Hose size	3/8"	3/8"
Air Inlet (NPT)	1/4"	1/4"
Product Weight	2.5 lb (1.13 kg)	5.5 lb (2.48 kg)
Sound Pressure	99.5	-
Vibration (m/s ²)	<2.5	-

RANDOM ORBITAL Accessories

PROD. NO.	Size	Description
905313	5"	Sanding Pad for 403203 (FS127A) / 403201 (FS127Q) / 403212 (DA63NV) / 403222 (DA63ZNV)
905310	6"	Sanding Pad for 403203 (FS127A) / 403201 (FS127Q) / 403212 (DA63NV) / 403222 (DA63ZNV)
905317	6" x 5/16"	Hole Vac Sanding Pad for 403217 (DA63CV)
502343	5" x 5/8" - 11NC	Gripper Back-Up Pad
502345	7" X 5/8-11 NC	Gripper Back-Up Pad
502352	4-1/2" X 5/8"-11 NC	Turbo Style Back-Up Pad C/W Nut
502353	5" X 5/8"-11 NC	Turbo Style Back-Up Pad C/W Nut
502354	7" X 5/8"-11 NC	Turbo Style Back-Up Pad C/W Nut



905310



905313



905317

For maximum performance we recommend 90 PSI air pressure



JET carries a wide range of abrasive and scrim back surface conditioning belts for this sander. Please consult the JET abrasives catalogue or visit our website.



FILE BELT SANDERS

- Sanding arm adjusts to any angle
- Easy belt and contact arm changes, no tools required
- Adjustable belt tracking mechanism
- Insulated comfort grip
- Safety toggle on throttle lever prevents accidental start-ups
- Easy swivel air inlet prevents hose twisting
- Air outlet swivels 360° allowing exhaust to be directed away from the operator

Multi-Head File Belt Sander Kit with Case - Heavy Duty

403351 / BS2518K

- Portable belt sander kit, complete with five interchangeable contact arms for maximum versatility
- Side handle offers extra operator control
- Side safety cover
- The ideal product to accomplish every file sanding job imaginable!

Standard Accessories: Hex key, blow mould case

Abrasive Belts:(1 each): 1/4" x 18" 150 grit, 3/8" x 18" 120 grit, 3/8" x 18" 150 grit, 1/2" x 18" 120 grit, 3/4" x 18" 60 grit, 3/4" x 18" 80 grit

Contact Arms: 3/4" x 18" (905321), 1/2" x 18" (905322), 3/8" x 18" (905323), 3/8" x 18" (905324), 1/4" x 18" (905325)

3/4" x 20-1/2" File Belt Sander - Heavy Duty

403355 / BS75205

- For easy access on hard to reach applications
- Hinged side cover and extended upper belt guard for additional safety
- 3/4" x 20-1/2" is a common industry size
- Can be used with sanding belts and surface conditioning belts

Standard Accessories: 3/8" x 20-1/2" belt, 80 grit, hex key

Sanding arm adjusts to any angle



PROD. NO. MOD. NO.	403351 BS2518K	403355 BS75205
Sanding Belt Size	1/4" x 18", 3/8" x 18", 1/2" x 18", 3/4" x 18"	3/4" x 20-1/2"
Free Speed (RPM)	18,000	16,000
Horse Power	.5	.5
Avg. Air Consumption (cfm)	4	4
Min. Hose size	3/8"	3/8"
Air Inlet (NPT)	1/4"	1/4"
Sound Pressure (dBA)	85	80
Vibration (m/s ²)	0.8	0.8
Product Weight	2.9 lb (1.31 kg)	3 lb (1.35 kg)
Overall Length	15-1/2"	15-3/16"

SPRAY GUNS





AIR SPRAY GUNS



HVLV Gravity Feed Spray Gun - Heavy Duty

409124 / SG600HVLV

- Gravity feed, high volume, low pressure paint spray gun
- Reduces paint over-spray for lower paint costs and cleaner, safer work area
- Ideal for large area paint jobs requiring professional results
- Featuring Teflon® finish for easy cleaning and excellent resistance to chemical corrosion
- Precision machined and finished, stainless steel nozzle and needle and brass cap provide highest quality results (905411)

Standard Accessories: 600 ml nylon cup with lid (905402), air regulator with dial (408812)

Optional Accessories:

- Needle, nozzle and cap set, 1.4 mm (905411)
- Needle, nozzle and cap set, 1.7 mm (905414)
- Needle, nozzle and cap set, 2.0 mm (905415)
- Nylon lid only 600ml cup (905403)
- Polished aluminum cup with lid 600ml (905404)
- Polished aluminum cup with lid 1 litre (905412)
- Lid only for 600ml polished aluminum cup (905405)
- Lid only for 1 litre polished aluminum cup (905413)
- Fine mesh paint strainer for gravity spray gun 3pc/bag, order in quantity of 3 or multiples thereof (905432)
- Fine mesh paint strainer for gravity spray gun 10pc/bag, order in quantities of 10 or multiples thereof (905433)

Working Air Pressure (PSI)	43 - 60
Maximum Air Pressure (PSI)	63
Min. Compressor Size	2
Fluid Inlet Thread	M16 x 1.5
Nozzle Size (mm)	1.4
Avg. Air Consumption (cfm)	11
Air Inlet (NPT)	1/4"
Length x Height	6.7 x 12.8"
Product Weight with Cup	1.6 lb (0.72 kg)

High Pressure Gravity Feed Spray Gun - Heavy Duty 409123 / SG600

- Gravity feed high pressure paint spray gun
- Featuring Teflon® finish for easy cleaning and excellent resistance to chemical corrosion
- Ideal for large area paint jobs requiring professional results
- Precision machined and finished, stainless steel nozzle and needle and brass cap provide highest quality results

Standard Accessories: 600ml nylon cup with lid (905402)

Optional Accessories:

- Needle, nozzle and cap set, 1.4 mm (905401)
- Needle, nozzle and cap set, 1.7mm (905406)
- Needle, nozzle and cap set, 2.0mm (905407)
- Nylon lid only 600ml cup (905403)
- Polished aluminum cup with lid 600ml (905404)
- Polished aluminum cup with lid 1 litre (905412)
- Lid only for 600ml polished aluminum cup (905405)
- Lid only for 1 litre polished aluminum cup (905413)
- Fine mesh paint strainer for gravity spray gun 3pc/bag, order in quantity of 3 or multiples thereof (905432)
- Fine mesh paint strainer for gravity spray gun 10pc/bag, order in quantities of 10 or multiples thereof (905433)



High Pressure Spray Gun - Heavy Duty 409128 / SG1S

- Professional quality high pressure air spray gun
- Air cap assembly designed for a perfect non-lead spray fan effect
- Precision ground tapered stainless steel needle
- Brass aluminum rivets ensure easy on and off clamping
- Aluminum alloy body with special anti-corrosion treatment
- Chrome plated brass material and pattern adjustment controls
- This deluxe, external mix, non-bleeder industrial spray gun can handle all kinds of paint, lacquer, stain, etc. for automotive finishing, industrial applications and furniture finishing
- **Note:** Not recommended for water-based paints

PROD. NO. MOD. NO.	409123 SG600	409128 SG1S
Working Air Pressure (PSI)	50 - 70	43 - 90
Maximum Air Pressure (PSI)	90	-
Min. Compressor Size	2	3
Fluid Inlet Thread	M16 x 1.5	3/8" NPS
Nozzle Size (mm)	1.4	1.8
Avg. Air Consumption (cfm)	8	12 - 15
Air Inlet (NPT)	1/4"	1/4" NPT
Length x Height	6.7 x 12.8"	6.5" x 11-1/2"
Product Weight with Cup	1.6 lb (0.72 kg)	2.2 lb (1 kg)





SPRAY GUN

Accessories



1/4" NPT Air Dial Regulator with Gauge for Spray Guns

408812 / AR600

- Designed specifically for use with 409124 (HVLP) paint spray guns
- Compact dial regulator provides precise air pressure settings for all painting applications
- Positive setting lock assures constant air pressure to the air tool
- Maximum air pressure input: 135 PSI
- Effective rate of adjustment: 7 - 120 PSI
- Maximum working temperature: 60°C (140°F)
- 1/4" NPT air inlet and outlet



1/4" NPT In-Line Air Regulator for 409124 (HVLP) Spray Guns

408816 / AR125

- Designed specifically for use with 409124 (HVLP) detail spray guns



905401

409123 (SG600) Needle, Nozzle, and Cap Set

PROD. NO.	Description
905401	Needle, Nozzle, and Cap Set 1.4mm
905406	Needle, Nozzle, and Cap Set 1.7mm
905407	Needle, Nozzle, and Cap Set 2.0mm



905402



905404

409124 (SG600HVLP) Needle, Nozzle, and Cap Set

PROD. NO.	Description
905411	Needle, Nozzle, and Cap Set 1.4mm
905414	Needle, Nozzle, and Cap Set 1.7mm
905415	Needle, Nozzle, and Cap Set 2.0mm



905432

Spray Gun Accessories for 409123 (SG600) & 409124 (SG600HVLP)

PROD. NO.	Description
905402	Nylon Cup with Lid for 600ml
905403	Lid Only for 600ml Nylon Cup
905404	600ml Aluminum Cup with Lid
905405	Lid for 600 ml Aluminum Cup
905412	1l Aluminum Cup with Lid
905413	Lid for 1l Aluminum Cup
905432	Fine Mesh Paint Strainer for Gravity Paint Gun (3 Pack)
905433	Fine Mesh Paint Strainer for Gravity Paint Gun (10 Pack)

ORDER IN PIECE COUNT QUANTITIES OR MULTIPLES THEREOF

AIR LINE TOOLS





FILTERS, REGULATORS AND LUBRICATORS

JET prides itself by carrying some of the best quality air tools in the world. However, like all air tools, performance and life can be severely compromised due to water and/or debris in the air line system, improper lubrication and/or improper air pressure supplied to the tool itself.

The diagram below outlines a basic air line system that should be used when operating air tools. This includes the proper placement and use of air filters, regulators and lubricators to ensure that clean, waterless air, arrives at the tool with the correct mix of oil lubrication and air pressure to achieve peak performance and tool life. Further, it is critical that accumulated air moisture be drained daily and sometimes more frequently from your air tank and air line system. Internal rust due to excessive moisture is one of the most common problems found in air tools sent in for repair. By maintaining your air tools through proper lubrication and ensuring the use of clean, dry air you extend their life and protect your warranty.

Sample Shop Air Piping Layout

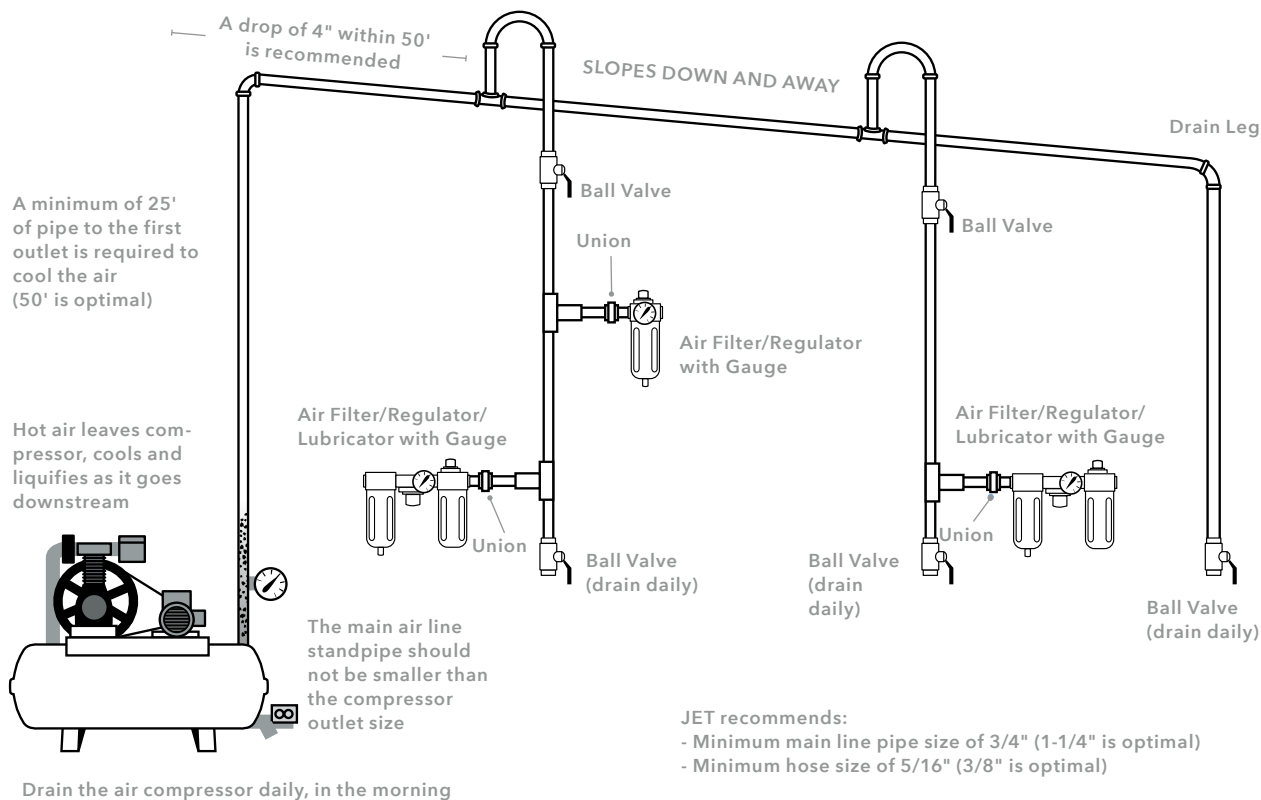

Air Tool Oiler
408832



Brass Air Regulator
408811



3 PC Air Filter, Regulator and
Lubricator 1" NPT -
Heavy Duty - 408858



Pressure Gauge - 1/4" NPT
Heavy Duty - 408814

- Industrial construction **aluminum die cast** body (9 times safer than a plastic body). Allows use at higher temperatures and better tightening of piping without stripping the threads.
- Built-in **wall mounting brackets**.
- **Built-in piping adapters** allows individual components to be easily removed/mounted without disturbing the pipe line.
- **Steel bowl guard** protects the polycarbonate bowl from getting damaged.
- **Filter unit** incorporates both separator and shield for maximum moisture separation.
- **Sintered bronze filtering element** versus commonly used paper filter provides for better filtration without the need to replace the filter element.
- **Press type manual drain** incorporates "Night Time Drain" feature which automatically drains off the bowl when compressed air supply is switched off.

Other Features

- Each unit is 100% factory tested and certified for guaranteed performance
- Designed for maximum flow with proper sizing of all components
- Fully modular for easy maintenance





FILTERS, REGULATORS AND LUBRICATORS

To increase pressure - pull knob, turn clockwise and push it back to lock in position. To reduce pressure - pull knob, turn counter clockwise and push it back to lock in position



Port for Installing Pressure Gauge 408818

Standard Configuration

- Pressure adjustment range of 7 - 145 PSI (0.5 - 10 BAR)

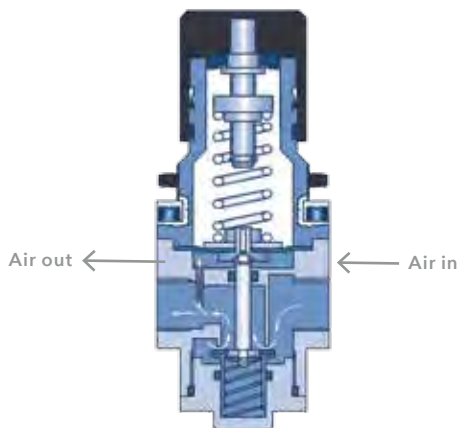

Air Regulators

408817 / 408818	408823 / 408821	408825	408826 / 408828
Miniature	Intermediate	Standard	Heavy Duty
Max. flow rate: 21 CFM / 600 LPM	Max. flow rate: 88 CFM / 2,500 LPM	Max. flow rate: 140 CFM / 4,000 LPM	Max. flow rate: 210 CFM / 6,000 LPM
	Built-in Venturi for flow compensation	Built-in Venturi for flow compensation	Built-in Venturi for flow compensation



Factory Tested



220 PSI (15 BAR)



Ambient 0-60°C (32-140°F)

MODULAR
MOUNTING

PANEL
MOUNTING

CONFORMS TO
ISO 6953-1

- One of the most commonly used air line accessories, regulators are used to maintain a steady outlet pressure, unaffected by variations/fluctuations in the inlet pressure
- Regulators step down the air line pressure and can be set at any pressure below the inlet air pressure
- Aluminum die cast body, designed with a non-raising "Press to Lock" adjusting knob for locking at any set pressure
- Regulators work on a diaphragm operated relieving type mechanism with pressure compensated by balanced poppet. These can be installed in any position

Wetted Components:

Aluminum, brass, steel, acetal, stainless steel and nitrile

PROD. NO.	MOD. NO.	Description	Port Size	Flow Rate (Max)*		Pressure Gauge Port Size	Height (h)		Width (w)	
				CFM	LPM		in	mm	in	mm
408817	ARM18	Miniature	1/8"	21	600	1/8"	3.19	81	1.57	40
408818	ARM14	Miniature	1/4"	21	600	1/8"	3.19	81	1.57	40
408821	ARI14	Intermediate	1/4"	88	2,500	1/8"	5.31	135	2.16	55
408823	ARI38	Intermediate	3/8"	88	2,500	1/8"	5.31	135	2.16	55
408825	ARS12	Standard	1/2"	140	4,000	1/8"	6.50	165	2.75	70
408826	ARH34	Heavy Duty	3/4"	175	5,000	1/4"	6.97	177	3.54	90
408828	ARH1	Heavy Duty	1"	210	6,000	1/4"	6.97	177	3.54	90

* Inlet pressure 105 PSI (7 BAR), supply pressure 90 PSI (6 BAR) and pressure drop 17 PSI (1 BAR)

ACCESSORIES AVAILABLE:



Clamp



Pressure Gauge

Air Filters			
408871 / 408872	408873 / 408874	408875	408878 / 408879
Miniature	Intermediate	Standard	Heavy Duty
Max. flow rate: 28 CFM / 800 LPM	Max. flow rate: 80 CFM / 2,250 LPM	Max. flow rate: 125 CFM / 3,500 LPM	Max. flow rate: 230 CFM / 6,500 LPM
Threaded type steel bowl guard.	Bayonet type steel bowl guard	Bayonet type steel bowl guard	Bayonet type steel bowl guard



Factory Tested



145 PSI (10 BAR)



Ambient 0-60°C (32-140°F)

MODULAR MOUNTING

VERTICAL MOUNTING

CONFORMS TO **ISO 5782-1**

- Air filters are used to separate dust, dirt, moisture and other contaminants from compressed air
- Die cast aluminum filter head, polycarbonate bowl with a steel bowl guard and high performance sintered bronze filtering element
- Designed with a separator and shield for efficient moisture separation

Wetted Components:

Aluminum, bronze, steel, acetal, polycarbonate, stainless steel and nitrile

PROD. NO.	MOD. NO.	Description	Port Size	Flow Rate (Max)*		Bowl Size		Height (h)		Width (w)	
				CFM	LPM	oz.	ml	in	mm	in	mm
408871	AFM18	Miniature	1/8"	28	800	0.3	9	4.45	113	1.57	40
408872	AFM14	Miniature	1/4"	28	800	0.3	9	4.45	113	1.57	40
408873	AFI14	Intermediate	1/4"	80	2,250	1.08	32	5.51	140	2.16	55
408874	AFI38	Intermediate	3/8"	80	2,250	1.08	32	5.51	140	2.16	55
408875	AFS12	Standard	1/2"	125	3,500	1.5	44	6.77	172	2.75	70
408878	AFH34	Heavy Duty	3/4"	175	5,000	5.6	165	10.24	260	3.54	90
408879	AFH1	Heavy Duty	1"	230	6,500	5.6	165	10.24	260	3.54	90

* Inlet pressure 90 PSI (6 BAR) and pressure drop 4.5 PSI (0.3 BAR)

ACCESSORIES AVAILABLE:



Clamp



Standard Configuration

- 40 micron filtering element
- Press type manual drain with "Night Time Drain" feature which automatically drains off the bowl once the compressed air supply to the filter is switched off

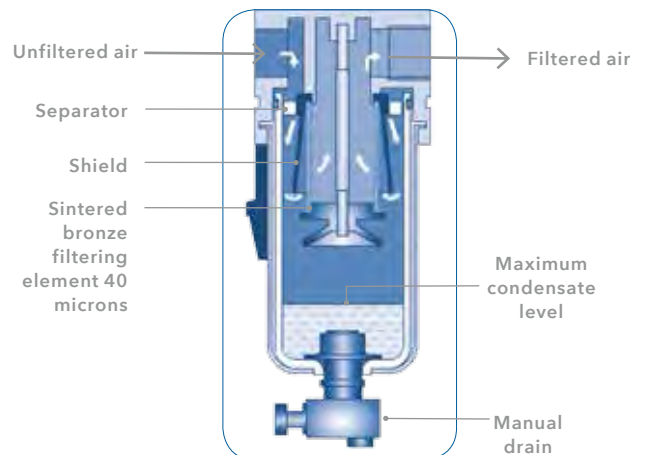

WARNING: Polycarbonate bowls may get damaged and possibly fail if exposed to synthetic oils, thinner, solvents, trichloroethylene, kerosene or other aromatic hydrocarbons



FILTERS, REGULATORS AND LUBRICATORS



408842

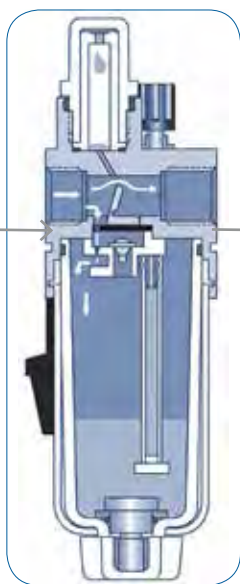

Filtered air

Lubricated air

Air Lubricators

408831 / 408833	408836	408842	408847 / 408849
Miniature	Intermediate	Standard	Heavy Duty
Max. flow rate: 21 CFM / 600 LPM	Max. flow rate: 106 CFM / 3,000 LPM	Max. flow rate: 200 CFM / 5,650 LPM	Max. flow rate: 318 CFM / 9,000 LPM
Min. flow rate: 0.42 CFM / 12 LPM	Min. flow rate: 1.41 CFM / 40 LPM	Min. flow rate: 1.59 CFM / 45 LPM	Min. flow rate: 1.76 CFM / 50 LPM
Threaded type steel bowl guard	Bayonet type steel bowl guard	Bayonet type steel bowl guard	Bayonet type steel bowl guard



Factory Tested



145 PSI (10 BAR)



Ambient 0-60°C (32-140°F)

MODULAR MOUNTING

PANEL MOUNTING

CONFORMS TO **ISO 6953-1**

- Air lubricators are used to feed lubricants to pneumatic equipment. These maintain a constant oil-to-air density over a wide range of flow
- Lubricators are fog/micro mist type, up to 50' pipe runs
- Die cast aluminum head, polycarbonate bowl with a steel bowl guard. The head is fitted with oil drop indicator, oil drop controller and oil filling plug

Wetted Components:

Aluminum, bronze, steel, acetal, polycarbonate, stainless steel and nitrile

Note: Designed for best performance with 32 grade oil

PROD. NO.	MOD. NO.	Description	Port Size	Flow Rate (Max)*		Bowl Size		Height (h)		Width (w)	
				CFM	LPM	oz.	ml	in	mm	in	mm
408831	ALM18	Miniature	1/8"	48	1,350	0.68	20	5.31	135	1.57	40
408833	ALM14	Miniature	1/4"	48	1,350	0.68	20	5.31	135	1.57	40
408836	ALI38	Intermediate	3/8"	106	3,000	1.98	57	6.18	157	2.16	55
408842	ALS12	Standard	1/2"	200	5,650	5.13	152	7.48	190	2.75	70
408847	ALH34	Heavy Duty	3/4"	255	7,200	6.8	200	10.75	273	3.54	90
408849	ALH1	Heavy Duty	1"	318	9,000	6.8	200	10.75	273	3.54	90

* Inlet pressure 90 PSI (6 BAR) and pressure drop 7.5 PSI (0.5 BAR)

ACCESSORIES AVAILABLE:



Clamp



WARNING: Polycarbonate bowls may get damaged and possibly fail if exposed to synthetic oils, thinner, solvents, trichloroethylene, kerosene or other aromatic hydrocarbons.

Filter, Regulator Combo			
408881 / 408882	408883 / 408884	408885	408888 / 408889
Miniature	Intermediate	Standard	Heavy Duty
Max. flow rate: 20 CFM / 550 LPM	Max. flow rate: 64 CFM / 1,800 LPM	Max. flow rate: 106 CFM / 3,000 LPM	Max. flow rate: 193 CFM / 5,500 LPM
Threaded type steel bowl guard.	Bayonet type steel bowl guard, regulator with built-in Venturi for flow compensation	Bayonet type steel bowl guard, regulator with built-in Venturi for flow compensation	Bayonet type steel bowl guard, regulator with built-in Venturi for flow compensation



Factory Tested



145 PSI (10 BAR)



Ambient 0-60°C (32-140°F)

MODULAR
MOUNTING

PANEL
MOUNTING

- The filter, regulator combination is one of the most popular air preparation units. The 2 are assembled together to form a single unit
- Air filter is used to separate dust, dirt, moisture and other contaminants from compressed air
- Filter has a die cast aluminum body, polycarbonate bowl with a steel bowl guard and high performance sintered bronze filtering element
- Filter is designed with a separator and shield for efficient moisture separation. It is combined with a regulator which maintains a steady outlet pressure, unaffected by variations/fluctuations in the inlet pressure
- Regulators have a non-raising "Press to Lock" adjusting knob for locking at any set pressure. Regulators work on a diaphragm operated relieving type mechanism with pressure compensated by balanced poppet

Wetted Components:

Aluminum, bronze, brass, steel, acetal, polycarbonate, stainless steel and nitrile

PROD. NO.	MOD. NO.	Description	Port Size	Flow Rate (Max)*		Pressure Gauge		Bowl Size		Height (h)		Width (w)	
				CFM	LPM	Port Size	oz.	ml	in	mm	in	mm	
408881	AFRM18	Miniature	1/8"	20	550	1/8"	0.3	9	6.69	170	1.57	40	
408882	AFRM14	Miniature	1/4"	20	550	1/8"	0.3	9	6.69	170	1.57	40	
408883	AFRI14	Intermediate	1/4"	64	1,800	1/8"	1.08	32	8.66	220	2.17	55	
408884	AFRI38	Intermediate	3/8"	64	1,800	1/8"	1.08	32	8.66	220	2.17	55	
408885	AFRS12	Standard	1/2"	106	3,000	1/8"	1.5	44	11.02	280	2.76	70	
408888	AFRH34	Heavy Duty	3/4"	149	4,250	1/4"	5.6	165	14.6	370	3.54	90	
408889	AFRH1	Heavy Duty	1"	193	5,500	1/4"	5.6	165	14.6	370	3.54	90	

* Inlet pressure 105 PSI (7 BAR). Set pressure 90 PSI (6 BAR). Pressure drop 17 PSI (1 BAR)

ACCESSORIES AVAILABLE:



Clamp



Pressure Gauge



Manual drain incorporates automatic "Night Time Drain" feature

408885

Standard Configuration

- Pressure adjustment range of 7 - 145 PSI (0.5 - 10 BAR)
- 40 micron filtering element
- Press type manual drain with "Night Time Drain" feature which automatically drains off the bowl once the compressed air supply to the filter is switched off

WARNING: Polycarbonate bowls may get damaged and possibly fail if exposed to synthetic oils, thinner, solvents, trichloroethylene, kerosene or other aromatic hydrocarbons.



FILTERS, REGULATORS AND LUBRICATORS



FRL - 2 Piece			
408801	408802	408804	408808 / 408809
Miniature	Intermediate	Standard	Heavy Duty
Max. flow rate: 18 CFM / 500 LPM	Max. flow rate: 44 CFM / 1,250 LPM	Max. flow rate: 99 CFM / 2,800 LPM	Max. flow rate: 140 CFM / 4,000 LPM
Min. flow rate: 0.42 CFM / 12 LPM	Min. flow rate: 1.41 CFM / 40 LPM	Min. flow rate: 1.59 CFM / 45 LPM	Min. flow rate: 1.76 CFM / 50 LPM
Threaded type steel bowl guard	Bayonet type steel bowl guard, regulator with built-in Venturi for flow compensation	Bayonet type steel bowl guard, regulator with built-in Venturi for flow compensation	Bayonet type steel bowl guard, regulator with built-in Venturi for flow compensation



Factory Tested



145 PSI (10 BAR)



Ambient 0-60°C (32-140°F)

MODULAR MOUNTING

VERTICAL MOUNTING

ACCESSORIES AVAILABLE:



Pressure Gauge

- Space saving 2 piece modular filter, regulator combination and lubricator is by far the most popular air preparation unit
- The filter, regulator combination and lubricator are attached in series using spacers and piping adapters, which makes the two components easily removable / mountable without disturbing the pipe line. Comes complete with a wall mounting bracket
- Air filter is used to separate dust, dirt, moisture and other contaminants from compressed air. Filter has a die cast aluminum body, polycarbonate bowl with a steel bowl guard and a high performance sintered bronze filtering element. Filter is designed with a separator and shield for efficient moisture separation
- Regulator maintains a steady outlet pressure, unaffected by variations/fluctuations in the inlet pressure. Regulators have a non-raising "Press to Lock" adjusting knob for locking at any set pressure. Regulators work on a diaphragm operated relieving type mechanism with pressure compensated by balanced poppet
- Air lubricators are used to feed lubricants to pneumatic equipments. These maintain a constant oil-to-air density over a wide range of flow. Lubricators are fog/micro-mist type, up to 50' pipe runs. Designed for best performance with 32 grade oil. These have a die cast aluminum head, polycarbonate bowl with a steel bowl guard. The head is fitted with oil drop indicator, oil drop controller and oil filling plug

Wetted Components:

Aluminum, bronze, brass, steel, acetal, polycarbonate, stainless steel and nitrile

PROD. NO.	MOD. NO.	Description	Port Size	Flow Rate (Max)*		Pressure Gauge		Bowl Size (Filter)		Bowl Size (Lubricator)		Height (h)		Width (w)	
				CFM	LPM	Port Size	oz.	ml	oz.	ml	in	mm	in	mm	
408801	AFRLCM14	Miniature	1/4"	18	500	1/8"	0.3	9	0.68	20	6.69	170	5.75	146	
408802	AFRLC138	Intermediate	3/8"	44	1,250	1/8"	1.08	32	1.93	57	8.66	220	7.17	182	
408804	AFRLCS12	Standard	1/2"	99	2,800	1/8"	1.5	44	5.17	152	11.02	280	8.66	220	
408808	AFRLCH34	Heavy Duty	3/4"	123	3,500	1/4"	5.6	165	6.8	200	14.6	370	10.63	270	
408809	AFRLCH1	Heavy Duty	1"	140	4,000	1/4"	5.6	165	6.8	200	14.6	370	10.63	270	

* Inlet Pressure 105 PSI (7 BAR). Set Pressure 90 PSI (6 BAR). Pressure Drop 17 PSI (1 BAR)



WARNING: Polycarbonate bowls may get damaged and possibly fail if exposed to synthetic oils, thinner, solvents, trichloroethylene, kerosene or other aromatic hydrocarbons.

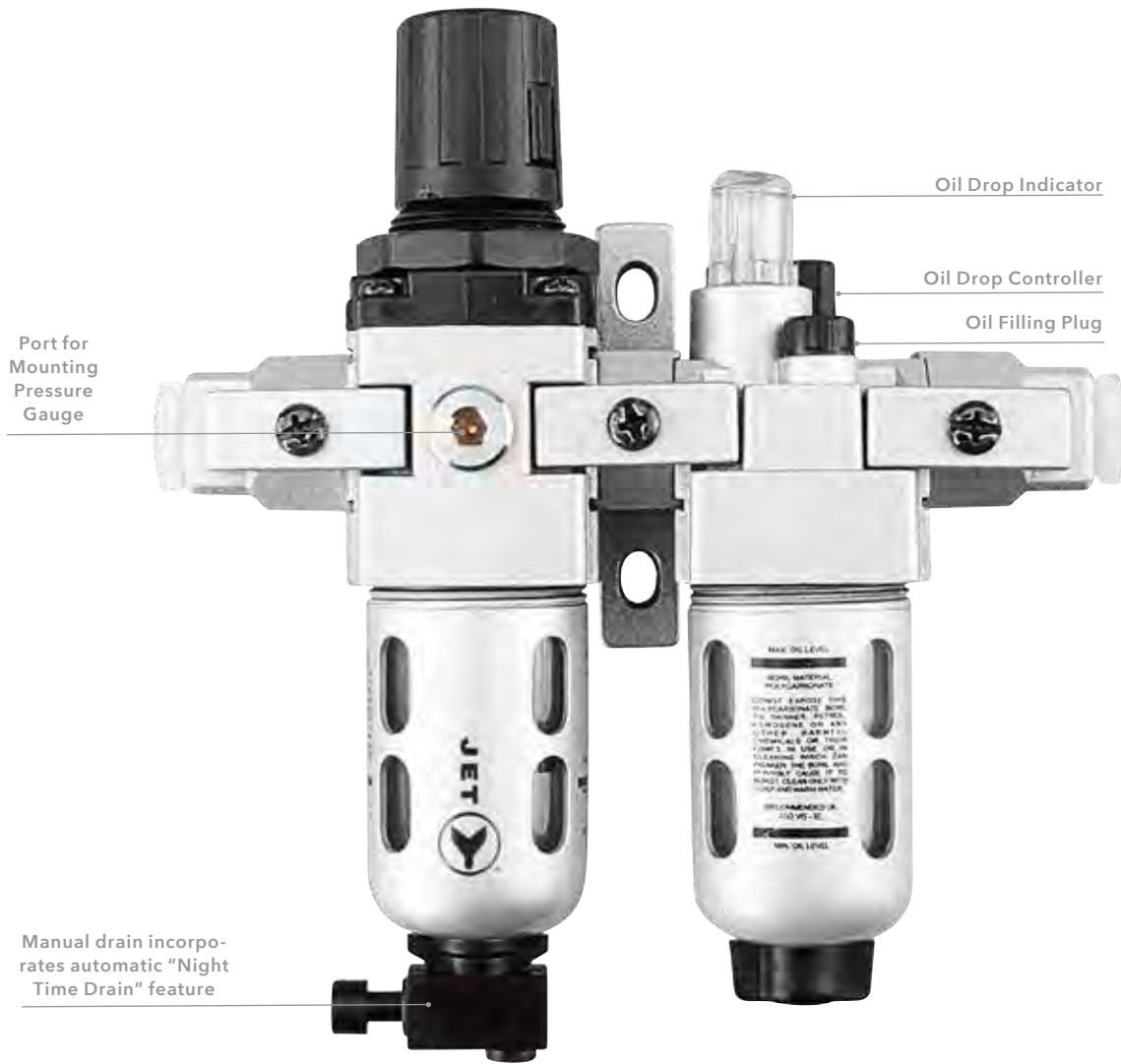

408801

Standard Configuration

- Pressure adjustment range of 7 - 145 PSI (0.5 - 10 BAR)
- 40 micron filtering element
- Press type manual drain with "Night Time Drain" feature which automatically drains off the bowl once the compressed air supply to the filter is switched off

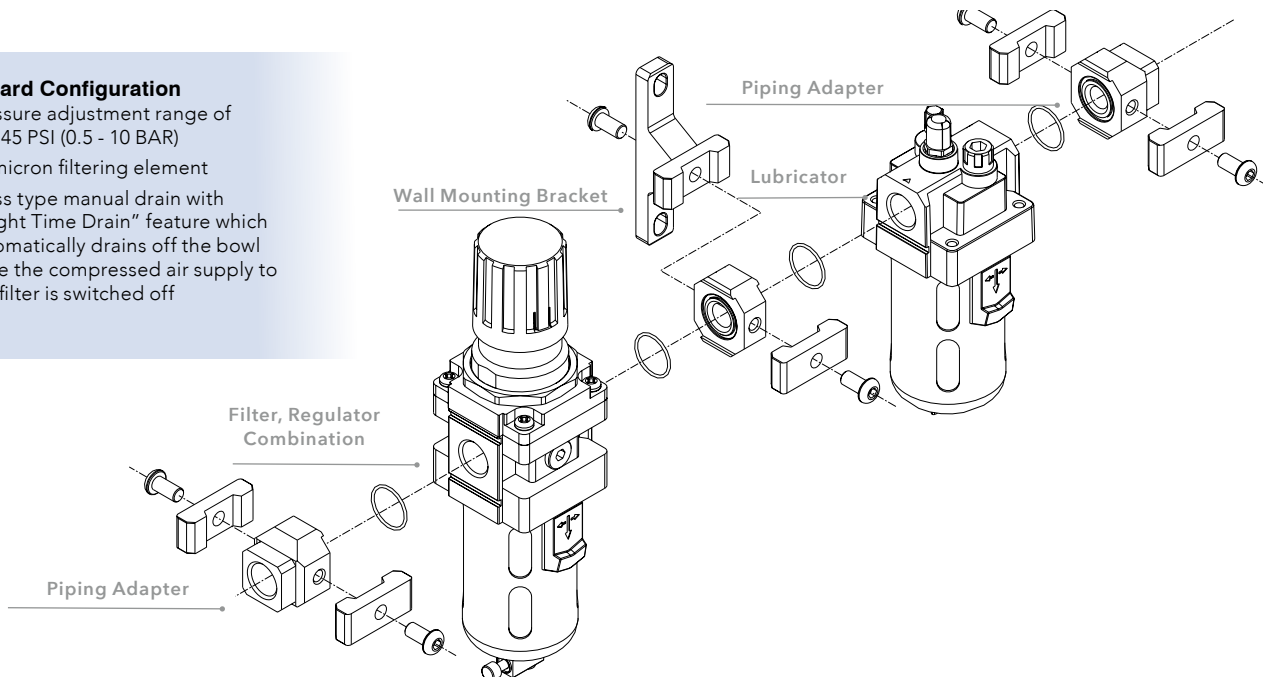



FILTERS, REGULATORS AND LUBRICATORS



FRL - 3 Piece			
408852	408855	408856	408857 / 408858
Miniature	Intermediate	Standard	Heavy Duty
Max. flow rate: 18 CFM / 500 LPM	Max. flow rate: 71 CFM / 2,000 LPM	Max. flow rate: 123 CFM / 3,500 LPM	Max. flow rate: 175 CFM / 5,000 LPM
Min. flow rate: 0.42 CFM / 12 LPM	Min. flow rate: 1.41 CFM / 40 LPM	Min. flow rate: 1.59 CFM / 45 LPM	Min. flow rate: 1.76 CFM / 50 LPM
Threaded type steel bowl guard	Bayonet type steel bowl guard, regulator with built-in Venturi for flow compensation	Bayonet type steel bowl guard, regulator with built-in Venturi for flow compensation	Bayonet type steel bowl guard, regulator with built-in Venturi for flow compensation



Factory Tested



145 PSI (10 BAR)



Ambient 0-60°C (32-140°F)

MODULAR MOUNTING

VERTICAL MOUNTING

ACCESSORIES AVAILABLE:



Pressure Gauge

- The filter, regulator and lubricator is a 3 piece assembly including all 3 individual components. The 3 components are attached in series using spacers and piping adapters, which make the individual components easily removable / mountable without disturbing the pipe line. Comes complete with wall mounting bracket
- Air filter is used to separate dust, dirt, moisture and other contaminants from compressed air. Filter has a die cast aluminum body, polycarbonate bowl with a steel bowl guard and a high performance sintered bronze filtering element. Filter is designed with a separator and shield for efficient moisture separation
- Regulator maintains a steady outlet pressure, unaffected by variations/fluctuations in the inlet pressure. Regulators have a non-raising "Press to Lock" adjusting knob for locking at any set pressure. Regulators work on a diaphragm operated relieving type mechanism with pressure compensated by balanced poppet
- Air lubricators are used to feed lubricants to pneumatic equipments. These maintain a constant oil-to-air density over a wide range of flow. Lubricators are fog/micro-mist type, up to 50' pipe runs. Designed for best performance with 32 grade oil. These have a die cast aluminum head, polycarbonate bowl with a steel bowl guard. The head is fitted with oil drop indicator, oil drop controller and oil filling plug

Wetted Components:

Aluminum, bronze, brass, steel, acetal, polycarbonate, stainless steel and nitrilel

PROD. NO.	MOD. NO.	Description	Port Size	Flow Rate (Max)*		Pressure Gauge Port Size	Bowl Size (Filter)		Bowl Size (Lubricator)		Height (h)		Width (w)	
				CFM	LPM		oz.	ml	oz.	ml	in	mm	in	mm
408852	AFRLMM14	Miniature	1/4"	18	500	1/8"	0.3	9	0.68	20	6.69	170	7.87	200
408855	AFRLMI38	Intermediate	3/8"	71	2,000	1/8"	1.08	32	1.93	57	8.66	220	9.84	250
408856	AFRLMS12	Standard	1/2"	123	3,500	1/8"	1.5	44	5.17	152	11.02	280	12.00	305
408857	AFRLMH34	Heavy Duty	3/4"	123	3,500	1/4"	5.6	165	6.8	200	14.6	370	14.6	370
408858	AFRLMH1	Heavy Duty	1"	175	5,000	1/4"	5.6	165	6.8	200	14.6	370	14.6	370



Standard Configuration

- Pressure adjustment range of 7 - 145 PSI (0.5 - 10 BAR)
- 40 micron filtering element
- Press type manual drain with "Night Time Drain" feature which automatically drains off the bowl once the compressed air supply to the filter is switched off

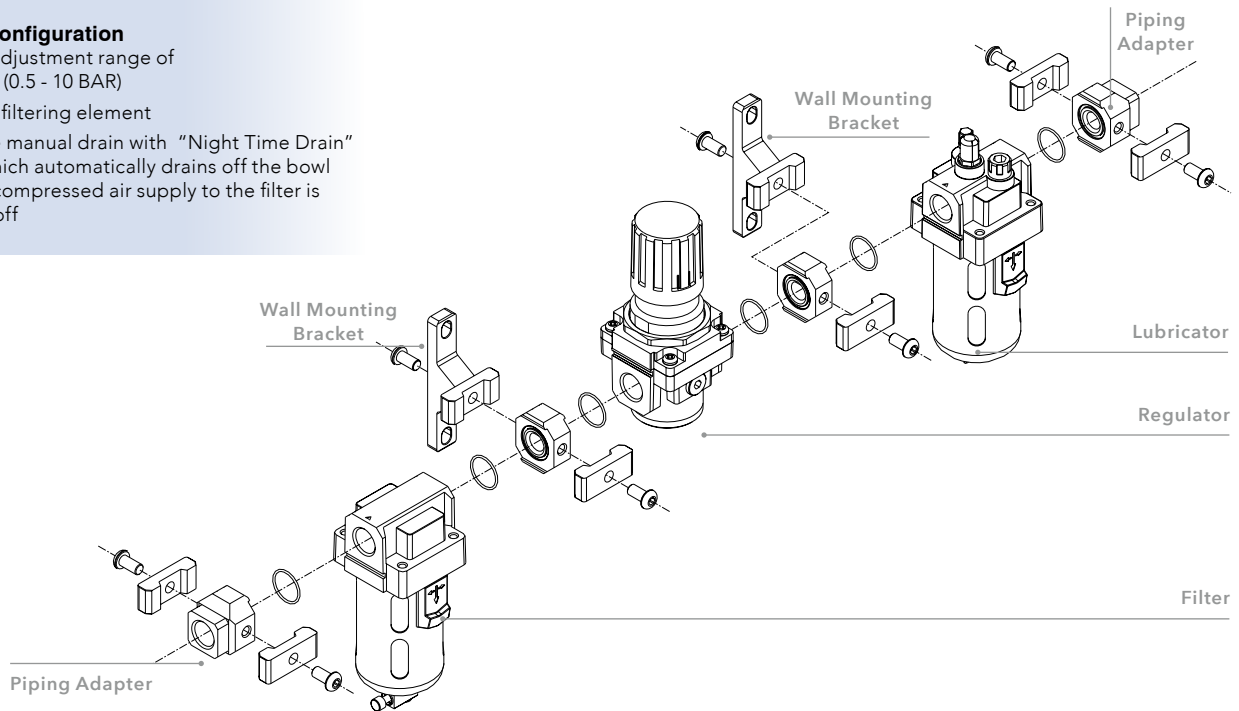

WARNING: Polycarbonate bowls may get damaged and possibly fail if exposed to synthetic oils, thinner, solvents, trichloroethylene, kerosene or other aromatic hydrocarbons.



FILTERS, REGULATORS AND LUBRICATORS

Accessories

Mounting Clamp for Individual Filters & Lubricators

- Steel clamps in a powder coated finish, used to mount individual filters and lubricators
- Both filter and lubricator units have threaded holes on the head casting into which the clamp fits



PROD. NO.	MOD. NO.	For Use with Model Series
408861	WMFLM	Miniature - AFM18, AFM14, ALM18, ALM14
408862	WMFLI	Intermediate - AFI14, AFI38, ALI38
408863	WMFLS	Standard - AFS12, ALS12
408864	WMFLH	Heavy Duty - AFH34, AFH1, ALH34, ALH1

Mounting Clamp for Regulators & Filter Regulator Combinations

- Steel clamps in a powder coated finish. The clamp has a hole into which the regulator fits in and is secured by the nut provided in the regulator



408865	WMFFRM	Miniature - ARM18, ARM14, AFRM18, AFRM14
408866	WMFFRI	Intermediate - ARI14, ARI38, AFR14, AFR18
408867	WMFFRS	Standard - ARS12, ARFS12
408868	WMFFRH	Heavy Duty - ARH34, AFRH34, ARH1, AFR1

Auto Drain Valve - External

- As a standard, all JET filters have a manual drain valve fitted on them, however, this can be changed with an automatic drain valve fitted externally to the bowl
- The auto drain valve drains the condensate water automatically. In addition to automatic draining, there is also provision in the valve for manual drain off
- Unlike an electrical auto drain valve, these float type auto drain valve's operate only when the condensate is collected and drains only the condensate



408891	ADVM	Miniature - AFM18, AFM14
408892	ADV1	Intermediate - AFI14, AFI38
408893	ADVS	Standard - AFS12
408894	ADVH	Heavy Duty - AFH34, AFH1

Pressure Gauges

- For use with regulators for setting output pressure. These are graduated both in BARS and PSI with a maximum reading of 200 PSI/14 BAR. Pressure Gauge is graduated in intervals of 5 PSI/0.20 BAR
- Male threads on the back side, fit female threads on the regulator



PROD. NO.	MOD. NO.	Threads NPT	For Use with Model Series
408813	RPGMIS18	1/8"	Miniature, Intermediate and Standard
408814	RPGH14	1/4"	Heavy Duty

1/4" NPT Air Tools Oiler

408832 / AAM014

- Automatically feeds oil into tool increasing performance and tool life
- Hooks up directly to air tools
- Visible oil supply provides precision oil metering
- Prevents air line contamination
- 1/4" NPT male/female threads



1/4" NPT Brass Air Regulator

408811 / AR5401

- Attaches to all air tools using 1/4" NPT air inlets
- Provides quick regulation of air flow on all air tools
- 1/4" NPT male/female threads



AIR FITTINGS



AIR FITTINGS



- Couplers have deep knurled socket sleeve
- Couplers have “4-Ball-Positive-Locking” mechanism
- Couplers and plugs made from “Zinc-Plated” steel to prevent rust from a moisture rich environment
- 1/4" Body x 1/4" NPT thread except where specified

APPLICATIONS

- General air service
- Pneumatic tools

SPECIFICATIONS

- Maximum Working Pressure - 150 PSI
- Air Flow – 35 SCFM at 100 PSI inlet with 10 PSI pressure drop
- Operating Temperature Range: -40°F to 225°F (-20°C to 107°C)

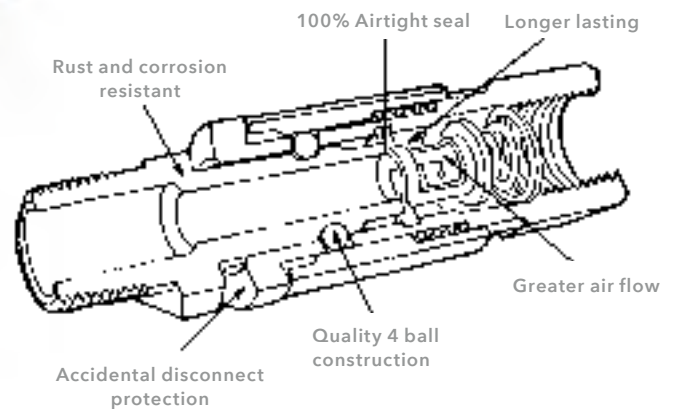

HOW TO IDENTIFY Plug Designs

Our standard sleeve type couplers and plugs are manufactured to ensure interchangeability with other makes of couplers and plugs. The type of plug and coupler determines if it is interchangeable with other makes, different types can't be interchanged, as they fit improperly, or will not fit, and are therefore unsafe for use.

"I/M" Industrial / Automotive Type Plug

- This type of plug has been adopted by all major manufacturers
- To identify this plug, look for the 3/16" tip
- V shape, flat bottom ball groove
- Complies with ANSI T3.20.14 dimensions



"T" Automotive Type Plug

- This type of plug has the shortest tip compared to the other plug types
- It has the widest section between the ball groove and the tip
- Thick sealing surface around the tip, which provides better sealing and longer seal life



"A" Type Plug

- To identify this plug, look for the 5/16" tip
- Round shape bottom ball groove



L Type Plug

- This is the most easily identified plug due to its long 3/4" tip
- Because of this tip length it can only be used with a matching L style coupler
- Round shape bottom ball groove





AIR FITTINGS

I/M Industrial/Automotive Type

1/4" Body x 1/4" NPT Thread

- Accepts 1/4" NPT industrial type plug

PROD. NO.	MOD. NO.	Description	Type	Thread	Material	Packaging	Pieces
420051	ICF1414	Coupler	Female	NPT	Steel	Blister / Card	1
422051	ICF1414B	Coupler	Female	NPT	Steel	Bulk	10
420052	ICM1414	Coupler	Male	NPT	Steel	Blister / Card	1
420001	IPM1414	Plug	Male	NPT	Steel	Blister / Card	2
422001	IPM1414B	Plug	Male	NPT	Steel	Bulk	20
420002	IPF1414	Plug	Female	NPT	Steel	Blister / Card	2
422002	IPF1414B	Plug	Female	NPT	Steel	Bulk	20

Note: Products sold in bulk packages must be ordered in bulk package quantities or multiples thereof.



I/M Type Coupler - Male



I/M Type Coupler - Female



I/M Type Plug - Male



I/M Type Plug - Female

I/M Type Air Fitting Sets 1/4" NPT Thread

PROD. NO.	MOD. NO.	Set Includes	Material	Packaging	Pieces
420091	I5PCS	1 PC Coupler Female, 3 PC Plug Male, 1 PC Plug Female	Steel	Blister / Card	5
420092	I2PCS	1 PC Coupler Female, 1 PC Plug Male	Steel	Blister / Card	2

1/4" Body x 3/8" NPT Thread

- Accepts 3/8" NPT industrial type plug

PROD. NO.	MOD. NO.	Description	Type	Thread	Material	Packaging	Pieces
420151	ICF1438	Coupler	Female	NPT	Steel	Blister / Card	1
420152	ICM1438	Coupler	Male	NPT	Steel	Blister / Card	1
420101	IPM1438	Plug	Male	NPT	Steel	Blister / Card	2
420102	IPF1438	Plug	Female	NPT	Steel	Blister / Card	2



420091



420092

L TYPE

1/4" Body x 1/4" NPT Thread

- Accepts 1/4" NPT L type plug

PROD. NO.	MOD. NO.	Description	Thread	Type	Material	Packaging	Pieces
420951	LCF1414	Coupler	Female	NPT	Steel	Blister / Card	1
420901	LPM1414	Plug	Male	NPT	Steel	Blister / Card	2
420902	LPF1414	Plug	Female	NPT	Steel	Blister / Card	2



L Type Coupler - Female



L Type Plug - Male



L Type Plug - Female

AIR FITTINGS

T Automotive Type



1/4" Body x 1/4" NPT Thread

- Accepts 1/4" NPT T automotive type plug

PROD. NO.	MOD. NO.	Description	Type	Thread	Material	Packaging	Pieces
420351	TCF1414	Coupler	Female	NPT	Steel	Blister / Card	1
420352	TCM1414	Coupler	Male	NPT	Steel	Blister / Card	1
420301	TPM1414	Plug	Male	NPT	Steel	Blister / Card	2
420302	TPF1414	Plug	Female	NPT	Steel	Blister / Card	2

T Type Air Fitting Set 1/4" NPT Thread

PROD. NO.	MOD. NO.	Set Includes	Material	Packaging	Pieces
420391	T5PCS	1 PC Coupler Female, 3 PC Plug Male, 1 PC Plug Female	Steel	Blister / Card	5



420391

A TYPE

1/4" Body x 1/4" NPT Thread

- Accepts 1/4" NPT A type plug

PROD. NO.	MOD. NO.	Description	Type	Thread	Material	Packaging	Pieces
420651	ACF1414	Coupler	Female	NPT	Steel	Blister / Card	1
422651	ACF1414B	Coupler	Female	NPT	Steel	Bulk	10
420652	ACM1414	Coupler	Male	NPT	Steel	Blister / Card	1
420601	APM1414	Plug	Male	NPT	Steel	Blister / Card	2
422601	APM1414B	Plug	Male	NPT	Steel	Bulk	20
420602	APF1414	Plug	Female	NPT	Steel	Blister / Card	2
422602	APF1414B	Plug	Female	NPT	Steel	Bulk	20

A Type Air Fitting Set 1/4" NPT Thread

PROD. NO.	MOD. NO.	Set Includes	Material	Packaging	Pieces
420691	A5PCS	1 PC Coupler Female, 3 PC Plug Male, 1 PC Plug Female	Steel	Blister / Card	5



T Type Coupler - Male



T Type Coupler - Female



T Type Plug - Male



T Type Plug - Female



A Type Coupler - Male



A Type Coupler - Female



A Type Plug - Male



A Type Plug - Female



U Universal Style Coupler - Male



U Universal Style Coupler - Female

U UNIVERSAL STYLE COUPLERS

- The 1/4" universal coupler will accept 1/4" I/M industrial, 1/4" T automotive or 1/4" A type NPT style plugs
- Automatic push-to-connect operation
- Sleeve guard protects against accidental disconnection when coupler is dragged on the floor or over obstructions
- Deep knurled socket sleeve
- Uses a 4-Ball-Positive-Locking mechanism
- Made from Zinc-Plated steel to prevent rust from a moist rich environment

1/4" Body x 1/4" NPT Thread

PROD. NO.	MOD. NO.	Description	Type	Thread	Material	Packaging	Pieces
421251	UCF1414	Coupler	Female	NPT	Steel	Blister / Card	1
421252	UCM1414	Coupler	Male	NPT	Steel	Blister / Card	1

3-WAY CONNECTORS



- Supply three air tools from a single air inlet
- Not necessary to connect and disconnect for every tool change
- Made from high strength aluminum
- Maximum inlet pressure - 150 PSI

APPLICATION

- General air service and pneumatic tools

3-Way Connectors

PROD. NO.	MOD. NO.	Kit Includes	Material	Packaging	Pieces
421501	3WMC14	One 1/4" FNPT Inlet x Three 1/4" FNPT Outlets	Aluminum	Blister / Card	1
421601	3WMC38	One 3/8" FNPT Inlet x Three 1/4" FNPT Outlets	Aluminum	Blister / Card	1

360° SWIVEL CONNECTORS



- Connect portable air tools to air hose
- 360° swivels in two places to prevent hose kinking and twisting
- Made from high strength aluminum and steel
- Maximum inlet pressure - 150 PSI
- Caution – not for use with percussion tools

APPLICATION

- General air service and pneumatic tools

360° Swivel Connector 1/4" NPT

PROD. NO.	MOD. NO.	Type	Material	Packaging	Pieces
421551	SC1414	1/4" FNPT x 1/4" MNPT	Aluminum and Steel	Blister / Card	1
421651	SC3838	3/8" FNPT x 3/8" MNPT	Aluminum and Steel	Blister / Card	1

- Innovative design allows trigger control air flow for all types of jobs
- Nickel plated finish resist corrosion
- Body material is plastic polyoxymethylene (POM)
- Equipped with two hang up hooks

4" Angled Tip Blow Gun - Heavy Duty

409903 / ABG-4

- Nozzle Material: Steel
- Working Inlet Pressure: 75 - 120 PSI
- Max. Inlet Pressure: 150 PSI
- Sound Pressure (dBA): 85 - 88
- Avg. Air Consumption (cfm) @ 90 PSI - 1/4" Hose: 13
- Avg. Air Consumption (cfm) @ 90 PSI - 3/8" Hose: 15
- Brass Air Inlet: 1/4" NPT female or 1/4" PT
- Temperature Range: -40° to 140°F



Brass inlet for longer life



Safety tip meets OSHA safety standards

4" Angled Tip Safety Blow Gun - Heavy Duty

409904 / ABG0-4

- Nozzle Material: Aluminum
- Working Inlet Pressure: 75 - 120 PSI
- Max. Inlet Pressure: 150 PSI
- Sound Pressure (dBA): 88 - 92
- Avg. Air Consumption (CFM) @ 90 PSI - 1/4" Hose: 13
- Avg. Air Consumption (CFM) @ 90 PSI - 3/8" Hose: 15
- Brass Air Inlet: 1/4" NPT female or 1/4" PT
- Temperature Range: -20° to 80°F
- Specially designed safety tip limits air blow pressure to a maximum 30 PSI - meets OSHA safety standards



6-1/2 - 11" Expandable Tip Blow Gun - Heavy Duty

409905 / ABGS-11

- Nozzle Material: Steel
- Nozzle Extension: 6-1/2 - 11" (165 - 280mm)
- Working Inlet Pressure: 75 - 110 PSI
- Max. Inlet Pressure: 150 PSI
- Sound Pressure (dBA): 85 - 88
- Avg. Air Consumption (CFM) @ 90 PSI - 1/4" Hose: 13
- Avg. Air Consumption (CFM) @ 90 PSI - 3/8" Hose: 15
- Brass Air Inlet: 1/4" NPT female or 1/4" PT
- Temperature Range: -40° to 140°F

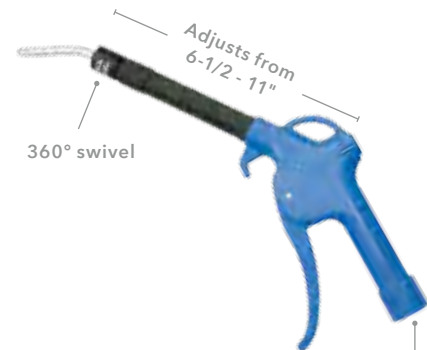

360° swivel

Adjusts from 6-1/2 - 11"

Brass inlet for longer life

Lever Air Blow Guns - Super Heavy Duty

- More than just your ordinary on/off blow gun. This blow gun incorporates a revolutionary Venturi mechanism that results in a more efficient volume of air flow
- Air flow regulated by operator control lever
- Manufactured from die cast aluminum; these are made to last in the harshest environments
- Ergonomic design of the body and large dip coated operating lever reduces user fatigue and discomfort, even during extended use
- Manufactured fully using non corroding materials, these are threaded 1/4" NPT (F) at inlet and 1/8" NPT (F) at outlet
- Meets OSHA standards



PROD. NO.	MOD. NO.	Description	Includes
409916	LABG-A	Lever Air Blow Gun	Conical Rubber Tip
409918	LABG-B	Lever Air Blow Gun	Standard Rubber Tip
409920	LABG-K	Lever Air Blow Gun Kit	Conical Rubber(409921), Standard Blow Gun Tip (409922), Standard Blow Gun with Safety Vent Tip(409923), High Flow Safety Tip(409924), Tapered Out Nylon Screen Tip (409931), Tapered in 3" Long Nylon Tip (409932), Tapered in Mini Aluminum Tip (409933), Adjustable Brass Tip (409936)



409916



AIR BLOW GUNS



4" Adjustable Flow Pocket Blow Gun - Heavy Duty

409908 / PBG-2

- Adjust from full volume air flow to complete shut off
- Knurled grip for finger control and sure grip for slippery fingers
- Equipped with shirt pocket clip
- All aluminum construction
- Comes with A style 1/4" NPT male coupler

Blow Gun

409902 / AG16

- 1/4" NPT air inlet
- Extra nozzle included
- Ideal for all air cleaning jobs

Uses less air consumption

Maximizes available air supply



409910

Soft Rubber Tip Blow Gun Stub Nose

409910 / ABG-2SD

- Stub nose design for use on soft materials that may get scratched if using a metal tip
- Special design uses significantly less air consumption while producing maximum air outflow at the tip
- Premium Nylon body offers highest resistance to impact & change in temperature
- Corrosion resistant stainless steel nozzle and internal parts for longer life
- Trigger springs made from stainless steel, offer higher resistance to corrosion
- Soft rubber grip for convenience in continuous use
- Ergonomic design helps eliminate carpal tunnel syndrome
- Brass threaded air inlet ensures that threads do not shear with repeated use
- Variable speed trigger allows maximum air flow control
- Silent operation with low noise level
- Meets OSHA safety standards
- Premium components and build quality ensure maximum life



Stainless Steel Nozzle Blow Gun 4 1/2"

409913 / ABG-45SD

- 4-1/2" tip enables you to get into those hard-to-reach places

PROD. NO. MOD. NO.	409910 ABG-2SD	409913 ABG-45SD
Noise Level (dBA) at 100 PSI	77	80
Air Consumption (cfm) at 100 PSI	6.0	5.3
Blowing Force	0.83 lb (0.38 kg)	0.76 lb (0.35 kg)
Operating Pressure (PSI)	50-235	50-235
Operating Temperature	-10° to 70°C (14° to 158°F)	-10° to 70°C (14° to 158°F)

AIR HOSE & HOSE REELS



RETRACTABLE HOSE REELS



391723

391728

- All body and frame components made of heavy gauge steel for longer life
- Spring powered automatic recoil
- Five position, adjustable guide arm
- Four direction, non-sag rollers to reduce hose wear
- Eight position ratchet gearing locks the reel at the desired hose length
- Solid brass swivel joint and machined brass fittings
- Can be wall, floor or ceiling mounted

Standard Accessories: Hose, ball stop and fittings

PROD. NO. MOD. NO.	391723 A3850	391728 A1250
Hose Diameter (ID)	3/8"	1/2"
Hose Length	50'	50'
Hose Inlet-Outlet (NPT)	1/4"	1/2"
Max. Hose Pressure (PSI)	300	300
Max. Air Flow (cfm)	25	25
Min. Temperature (°C / °F)	0/32	0/32
Max. Temperature (°C / °F)	100/210	100/210
Product Weight	39 lb (17.69 kg)	45 lb (20.41 kg)
Intended Use	Air	Air

RETRACTABLE HOSE REELS – HEAVY DUTY



391721

391726

- All body and frame components made of superior heavy gauge steel for professional applications/installations
- All metal parts powder coated for corrosion free performance
- Reinforced L-shaped base
- Professional super duty spring mechanism for long life
- Nine position, adjustable guide arm
- Heavy duty four direction, non snag rollers
- Anti lock-out ratchet mechanism prevents reel from locking up when hose is fully extended
- Heavy duty American made, solid brass swivel fitting
- Can be wall, floor or ceiling mounted

Standard Accessories: Hose and fittings

PROD. NO. MOD. NO.	391721 AW3825	391722 AW3850	391726 AW1250	391746 OA1450
Hose Diameter (ID)	3/8"	3/8"	1/2"	1/4"
Hose Length	25'	50'	50'	50'
Hose Inlet-Outlet (NPT)	3/8"	3/8"	1/2"	1/4"
Max. Hose Pressure (PSI)	300	300	300	300
Min. Temperature (°C / °F)	0/32	0/32	0/32	0/32
Max. Temperature (°C / °F)	100/210	100/210	100/210	60/140
Product Weight	29 lb (13.05 kg)	54 lb (24.3 kg)	59 lb (26.55 kg)	53 lb (23.85 kg)
Intended Use	Air / Water	Air / Water	Air / Water	Oxy-Acetylene



391746

NOTE: There are many similar looking air/water rewind hose reels in the market. However, these industrial quality JET reels offer heavier gauge body and frame steel components, superior American made air swivel fittings, an extra heavy duty spring mechanism (tested to 10,000 cycles) and a superior quality four direction snag roller system.

HAND CRANK HEELS



- Provides the ideal method for safe and economic handling of air and water hose
- Heavy duty steel drum and frame construction
- Corrosion resistant powder coating
- Spring tensioned brake prevents free wheeling
- Solid brass swivel and fittings
- 391742 (HC200) features brass and stainless steel fluid path
- Mount on floor, bench or service truck

PROD. NO. MOD. NO.	391741 HC100	391742 HC200
Hose Diameter (ID)	3/8"	3/8"
Hose Length	100'	100'
Hose Inlet-Outlet (NPT)	3/8"	3/8"
Max. Hose Pressure (PSI)	300	300
Product Weight	13 lb (5.85 kg)	14 lb (6.3 kg)
Intended Use	Air/Water	Air/Water

NOTE: Hose not included



391741



391742

HOSE REELS

Accessories

360° Universal Ceiling/Floor Mount Swivel Base for Reels

391739 / SRCF



391739

Wall Mount Swivel Base for Reels

PROD. NO.	MOD. NO.	Description	For
391729	SRW809	140°	391721 (AW3825)
391730	SRW808	140°	50' Reels 391722 (AW3850) 391726 (AW1250) 391746 (OA1450)



391729



RUBBER AIR HOSES

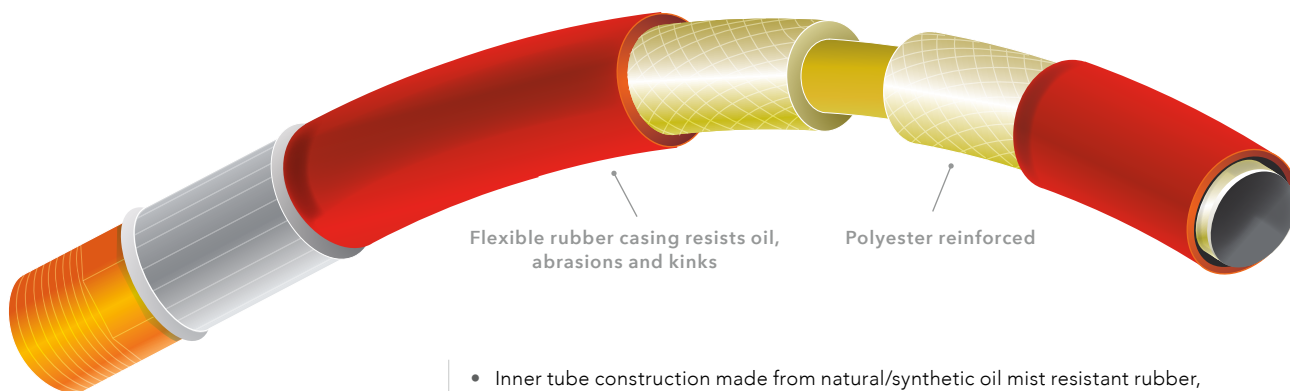

Flexible rubber casing resists oil, abrasions and kinks

Polyester reinforced



- Inner tube construction made from natural/synthetic oil mist resistant rubber, reinforced with high tenacity braided 1,500 denier filament yarn, for maximum strength and durability
- EPDM outer cover construction offers UV, oil and abrasion resistance for longer hose life and increased low temperature flexibility
- 1/4" (3/8" for 408142) fittings — solid crush proof couplings with 8 point crimp to ensure leak proof seal
- 300 PSI working pressure, 1,200 PSI burst pressure
- -30° to +70°C (-20° to +160°F) temperature range

300 PSI – Heavy Duty

PROD. NO.	MOD. NO.	ID Size	Hose Length	Fitting Size (NPT)	Product Weight
408132	AH1450RB	1/4"	50'	1/4"	9.5 lb (4.28 kg)
408136	AH3825RB	3/8"	25'	1/4"	5 lb (2.25 kg)
408137	AH3850RB	3/8"	50'	1/4"	9.5 lb (4.28 kg)
408142	AH1250RB	1/2"	50'	3/8"	12.3 lb (5.54 kg)

3/8" x 3' Air Hose Whip

408171 / AW383RB

- Natural / Synthetic Oil Mist Resistant Rubber
- Layers of High Strength Polyester Yarn
- Smooth Abrasion Resistant (Natural / EPDM Rubber)
- High Burst Strength, stays flexible in -30° to +82°C (-20° to +180°F)
- 1/4" NPT Male Brass with Thread Protector
- Cushioned sleeve for easy handling
- Maximum Working Pressure 300 PSI, Minimum Burst Strength 1,200 PSI

PVC AIR HOSES

300 PSI – Heavy Duty

- PVC air hose stays pliable in cold weather, use in temperatures ranging from -26° to +65°C (-14.8° to +149°F)
- Tough abrasion and oil resistant outer surface
- Cover is pin pricked for safety. If air seeps between layers pin holes allow it to escape, preventing sudden failure
- 300 PSI working pressure
- 1/4" NPT fittings are applied using hydraulic pressure to ensure a perfect seal and no damage to the hose under the fitting

PROD. NO.	MOD. NO.	Hose Length	ID Size (NPT)
408104	AH2538R	25'	3/8"
408105	AH5038R	50'	3/8"



RUBBER AIR HOSES JET SHD XTREME PERFORMANCE

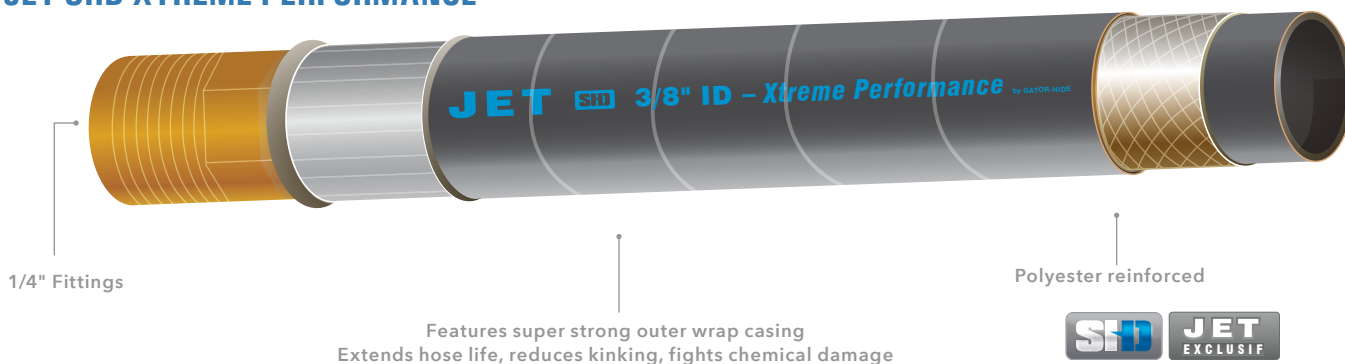

Features super strong outer wrap casing
Extends hose life, reduces kinking, fights chemical damage



JET SHD "Xtreme Performance" 3/8" Air Hose - Super Heavy Duty 408160 / AH3850RSD

- Wrapped finish for higher adhesion between plies. Outer cover construction offers UV, oil and abrasion resistance for longer hose life
- Inner tube construction made from natural/synthetic oil mist resistant rubber, reinforced with high tenacity braided 1,500 denier filament yarns, for maximum strength and durability
- Printed layline delivers exceptional flexibility and better life
- Bend restrictors reduce kinking
- 1/4" fittings - solid crush proof couplings with 8 point crimp to ensure leak proof seal
- 300 PSI working pressure, 1,200 PSI burst pressure
- -40° to +70°C (-40° to +160°F) temperature rang

ID Size	Hose Length	Fitting Size (NPT)
3/8"	50'	1/4"



TEMPERATURE RANGE -40°C (-40°F) ↔ 70°C (160°F)	WORKING PRESSURE 300 PSI
	BURST PRESSURE 1,200 PSI

RECOIL AIR HOSES

- Light, versatile, easy to handle and difficult to kink polyurethane construction
- Stores in 1/30 of working length
- 360° swivel ends, 1/4" NPT, male
- The most efficient system of storing and using air hose
- Temperature range: -15° to 40°C (5° to 104°F)

PROD. NO.	MOD. NO.	Hose Length	ID Size (NPT)	Working Pressure	Burst Pressure
408123	APUB-1425	25'	1/4"	90-200 PSI	200 PSI
408128	APUB-3825	25'	3/8"	90-200 PSI	250 PSI



408123

SAFETY GUIDE

BEFORE YOU START BE SAFETY SMART

CARRY THE TOOL BY THE HANDLE

Always carry the tool by the handle only. Never carry the tool by the air hose.

DO NOT EXCEED THE MAXIMUM RECOMMENDED AIR PRESSURE

Always use clean, dry air. Operate the tool only at the recommended air pressure. Do not exceed the maximum air pressure marked on the tool. Never use any bottled air or gases such as oxygen to operate the tool since they could cause the tool to explode. Be sure all hoses and fittings are the correct size and are tightly secured.

LUBRICATION

Oil daily, for additional information regarding oiling please refer to the operators manual.

GENERAL PRODUCT SAFETY INFORMATION

- Do not modify the tool, safety devices, or accessories.
- Do not use the tool for purposes other than those recommended for the tool.
- Never use a damaged or malfunctioning tool or accessory.
- Keep hands, loose clothing, long hair and jewelry away from working end of tool.
- When wearing gloves always be sure that the gloves will not prevent the throttle mechanism from being released.
- Ensure work pieces are secure. Use clamps or vises to hold work piece whenever possible.
- Always use Personal Protective Equipment appropriate to the tool used and material worked. This may include dust mask or other breathing apparatus, safety glasses, ear plugs, gloves, apron, safety shoes, hard hat and other equipment.

SAFETY GUIDELINES FOR SPECIFIC AIR TOOL CATEGORIES:

IMPACT WRENCHES

- Never use hand sockets. Use only impact sockets in good condition. Sockets in poor condition reduce impact power and could also shatter, resulting in personal injury.

DO NOT EXCEED THE MAXIMUM RECOMMENDED AIR PRESSURE

Always use clean, dry air. Operate the tool only at the recommended air pressure. Do not exceed the maximum air pressure marked on the tool. Never use any bottled air or gases such as oxygen to operate the tool since they could cause the tool to explode. Be sure all hoses and fittings are the correct size and are tightly secured.

- When using a universal joint, never free run the tool, it may run too fast and cause the joint to be thrown from the tool.
- Always use the simplest hook-up possible. Long springy extension bars and adapters absorb impact power and could break loose resulting in personal injury. Instead, use deep sockets whenever possible.
- For tools using the pin and o-ring socket retainer, use the o-ring to securely retain the socket pin.
- Periodically check the drive end of the tool to make certain that the socket retainer functions correctly, and that sockets and drive ends are not excessively worn which may allow the socket to come off when rotating.

AIR HAMMERS

- All chisels, rivet sets and other accessories should be checked for cracks, excessive wear, or other physical damage before each use. Accessories that show signs of damage should be replaced immediately.
- Never use a tool without the proper accessory retainer.

ACCESSORIES

- Always use accessories of correct size and design for the tool. Tool and accessories must not be modified in any way.
- Never use a tool without the proper accessory retainer.

RATCHET WRENCHES

- Never use hand sockets. Use only power drive sockets per ANSI B107.2. JET carries a full range of Impact Sockets, visit our Hand Tools section on our website at www.surewerx.com.
- To reduce the risk of injury, always support the handle securely in the direction opposite of the spindle rotation to minimize torque reaction.
- When wearing gloves always be sure that the gloves will not prevent the throttle mechanism from being released.
- Do not overreach when operating this tool. Anticipate and be alert for sudden changes in motion, reaction torques, or forces during start up and operation.
- Ratchet wrenches are not torque wrenches. Connections requiring specific torque must be checked with a torque wrench after fitting with a ratchet wrench.

GRINDERS AND SANDERS

- Always wear eye protection when operating or performing maintenance on this tool.
- Never mount a grinding wheel on a sander.
- Always wear hearing protection when operating this tool.
- Always use Personal Protective Equipment appropriate to the tool used and material worked.
- Keep hands, loose clothing, long hair and jewelry away from working end of tool.
- Ensure work pieces are secure. Use clamps or vises to hold work piece whenever possible.
- Ensure that the grinding wheel or other abrasive accessory is correctly mounted and tightened before use.
- Never use a grinding wheel marked with a speed lower than the rated air grinder speed.
- All grinding wheels and polishing/sanding accessories should be checked for cracks or other damage before mounting and use.
- Always use the recommended wheel guard to prevent injury when performing grinding operations. If a guard has withstood wheel or disc breakage, it must be replaced.
- Position a guard between the grinding wheel or disc and the operator. Use barriers to protect others from fragments and grinding sparks.
- Make sure grinding wheels are mounted according to manufacturer's specifications; always use correct mounting flanges.
- Before grinding, test grinding wheel or disc by briefly running tool at full throttle. Be sure to use a barrier (such as under a heavy work table) to protect yourself from possible broken wheel parts.
- Inspect arbor, threads & clamping devices for damage and wear prior to mounting wheel or other abrasive accessory.
- Never tamper with or remove a speed governor from a tool to make it run faster. Periodically check tool speed with a tachometer.
- Before a grinder is put down, the throttle shall be released and the wheel or other accessory shall come to a stop.
- To prolong tool life, always check abrasive stone rotational balance before each operation. Simply run the tool and check for any vibration. If vibration is present, then the abrasive stone is off centre. To align, use a diamond cutter to grind the stone until a balanced condition is reached.

AIR DRILLS

- Keep away from rotating bit and chuck. You could be cut or burnt if you come in contact with the drill bit, chips or work surface.

- Use intermittent drill pressure to avoid long shaved chips.
- The drill bit can suddenly bind and cause the work piece or tool to rotate causing arm and shoulder injuries.
- ANSI recommends use of a support handle on drills with a chuck larger than 3/8" (10 mm).
- Do not use any drill bits or other accessory having a maximum operating speed less than the free speed of the drill in which it is being used.
- Securely tighten drill bits or other accessories in the chuck before operating the drill. When using a chuck key, remove it before starting the drill.
- Anticipate the torque reaction developed when the drill bit snags or binds, which occurs when breaking through the material being drilled or when heavily loaded. If it snags or binds, release the trigger and remove the drill bit from the work piece by rotating it in the reverse direction

AIR HOSES

- Do not use damaged, frayed or deteriorated air hoses and fittings
- Use the proper hose and fittings of the correct diameter.
- Check hoses regularly for cuts, bulges and abrasions. Tag and replace, if defective.
- Blow out the air line before connecting a tool. Hold hose firmly and blow away from yourself and others.
- Ensure that hose connections fit properly and are equipped with a mechanical means of securing the connection
- Install quick disconnects of a pressure-release type rather than a disengagement type. Attach the male end of the connector to the tool, NOT the hose.
- Do not operate the tool at a pressure above the manufacturer's rating.
- Avoid creating trip hazards caused by hoses laid across walkways or curled underfoot.
- Do not use compressed air to blow debris or to clean dirt from clothes.

IMPORTANT

These safety instructions are meant to highlight sections of safety standards published by the American National Standards Institute and the Occupational Safety and Health Administration. They are not meant to replace those standards but only highlight certain areas.

When care is taken to ensure that the tool is operated properly and safety and maintenance procedures are followed, accidents can be avoided. Read and follow all instructions and directions, comply with all rules governing the use of power tools, personal protective equipment and equipment guards.

Remember – tools, attachments, and accessories must be used only for the purpose for which they were designed. Safety reasons and product liability prohibit any modifications to tools.

WARRANTY

WARRANTY POLICY

JET EQUIPMENT & TOOLS LTD. (JET), makes every effort to ensure its products are manufactured to the highest standards and are guaranteed against defects in materials and workmanship when the product is used for the purpose for which it was designed.

This guarantee applies only to JET products purchased new from a JET authorized distributor. JET product warranties are extended to the original retail purchaser only.

This warranty does not apply to any product showing signs of abuse, misuse, alteration, or having been improperly maintained or repaired.

This warranty does not cover damage attributable to normal wear and tear.

Any JET product that fails during normal use and is within the specified warranty period for that product will be repaired or replaced at JET's discretion. Repairs and/or replacements are warranted as described for the specific product and only for the remainder of the original warranty period.

Repair or replacement is the exclusive remedy for defective product under this warranty. Warranty is expressly in lieu of all other warranties, including the implied warranty of merchantability or any implied warranty of fitness for a particular application.

Any JET product for which there is a warranty claim should be returned PREPAID to an authorized JET distributor or service center. Authorized Warranty Depots are found at www.jetgroupbrands.com.

ALL warranty claims must be accompanied by proof of purchase and an explanation of the defect or failure. It is the customer's responsibility to provide this information.

JET shall not be held liable for any consequential or incidental damages for breach of any expressed or implied warranty on their products. No claims for damages of any type will be considered and all products are sold with this understanding.

Any costs incurred to obtain warranty consideration or services are the Customer's responsibility including shipping and handling, travel, lost time, or lost production.

SPECIFIED WARRANTY - AIR TOOLS

JET Air Tools

500 Days from the date of purchase.

Not included in this warranty are components and accessories which are considered consumable items or are subject to normal wear and tear.

MATERIAL HANDLING

SAFETY AND PRODUCTIVITY

DESIGN

With feature such as dual pawl brakes and steel drop stops, our products are designed with your safety in mind.

QUALITY

Using the materials like Chrome Molybdenum load gears and the world's strongest grade 105 load chain, our products are built with quality you can depend on.

STANDARDS

JET Material Handling products are individually load tested and built to meet or exceed ANSI standards.

DID YOU KNOW?

JET products are fully serviceable and parts are available to help extend their life



TABLE OF CONTENTS

Electric Hoists		555	
Single Speed Hoists.....	556	Accessories.....	557
Chain Hoists		559	
Chain Hoists.....	560-569	Chain Hoists with Overload Protection..	564-565
Lever Chain Pullers		570	
Lever Chain Pullers.....	570-579	Hand Cable Pullers.....	581
Wire Rope Pullers.....	580		
Trolleys and Clamps		582	
Beam Clamps.....	583	Plate Clamps.....	586
Manual Trolleys.....	585	Drum Lifter.....	586
Blocks & Sheaves		587	
Yarding Blocks.....	587	Sheaves.....	587
Snatch Blocks.....	587		
Winches		588	
Hand Winches.....	588		
Pallet Truck / Scissor Lift Hand Cart		589	
Warranty Policy.....	590	Safety Guide.....	591

ICON LEGEND

Good Quality		Overload Protection	
Better Quality		Canadian Standard for Over 25 Years	
Best Quality		Canadian Standard for Over 45 Years	
Super Heavy Duty		New	
Safety Hook		JET Exclusive	



ELECTRIC HOISTS





SINGLE SPEED HOISTS

FA Series – Heavy Duty

- Available in single phase or three phase models and various voltages (specify when ordering)
- 1/2 ton - 5 ton capacities
- Chain is heat treated, case hardened, low wear chain surpassing ISO Class T
- All models complete with chain collector bucket
- Reliable electro-magnetic DC brake engages automatically when power is cut off
- Two button pendant control automatically returns to OFF mode when either button is released
- 24 volt pendant control for operator safety in damp or humid conditions
- Strain relief cable protects electrical connections
- Top and bottom safety hooks designed to bend slowly to warn of overloads
- Upper and lower limit switches protect hoist from damage if load or chain stop contacts body
- Gear train and electrical components completely sealed for use outdoors (cover recommended)
- Modular construction of motor, gear train, and brake assembly allows for quick and easy maintenance
- Single phase hoists equipped with automatic overload protection preset to 110% of rated capacity
- Three phase hoists feature reverse phase protection
- Meets ASME B30.16, CSA, and OSHA standards
- Made in Japan

Note: Custom lifts are available in any length desired



PROD. NO.	MOD. NO.	Rated Lifting Capacity (Tons)	Rated Lifting Capacity (lb)	Standard Lift	Standard Chain Bucket	Hoisting Speed FPM	Voltage	Power Source
107202	FA1-0.5S	1/2	1,100	15'	#2	14	115 / 230V	1PH
107203	FA1-1S	1	2,200	15'	#2	10	115 / 230V	1PH
107204	FA1-2S	2	4,400	15'	#3	5	115 / 230V	1PH
107205	FA1-3S	3	6,600	15'	#4	3.3	115 / 230V	1PH
107206	FA-1-5S	5	11,000	15'	#5	2	115 / 230V	1PH
107212	FA-0.5S	1/2	1,100	15'	#2	28	230 / 460V	3PH
107213	FA-1S	1	2,200	15'	#2	24.2	230 / 460V	3PH
107214	FA-2S	2	4,400	15'	#3	12.1	230 / 460V	3PH
107215	FA-3S	3	6,600	15'	#4	8	230 / 460V	3PH
107216	FA-5S	5	11,000	15'	#5	4.8	230 / 460V	3PH
107262	FA-0.5S	1/2	1,100	15'	#2	28	575V	3PH
107263	FA-1S	1	2,200	15'	#2	24.2	575V	3PH
107264	FA-2S	2	4,400	15'	#3	12.1	575V	3PH
107265	FA-3S	3	6,600	15'	#4	8	575V	3PH
107266	FA-5S	5	11,000	15'	#5	4.8	575V	3PH

Chain Buckets

- Standard lift hoists are equipped with appropriate bucket. For extended lift hoists, multiply the feet of lift desired by the number of falls to obtain total chain length. Choose appropriate bucket from the list below.



PROD. NO.	MOD. NO	Maximum Chain Length 1/2 Ton	Maximum Chain Length 1-5 Ton	Number of Falls
PEL-21-2	#2	30'	20'	1/2 ton + 1 ton - 1
PEL-21-3	#3	50'	40'	2 ton - 2
PEL-21-4	#4	70'	60'	3 ton - 3
PEL-21-5	#5	120'	110'	5 ton - 5
PEL-21-6	#6	-	180'	-



1/2 Ton and 1 Ton FA and FA1



2 Ton FA and FA1



3 Ton FA and FA1



5 Ton FA and FA1

Rated Lifting Capacity (Tons)	A	B	C	D	H	K	L	M	N	O
1/2	6.34"	4.88"	8.82"	12.24"	18.90"	1.42"	1.02"	3.39"	.94"	.75"
1	6.69"	5.04"	9.41"	13.72"	22.44"	1.69"	1.30"	4.21"	1.22"	.91"
2	5.24"	6.50"	9.41"	14.65"	27.95"	2.09"	1.65"	5.67"	1.73"	1.18"
3	5.83"	8.19"	9.41"	16.81"	31.89"	2.36"	1.97"	6.50"	1.93"	1.38"
5	7.20"	10.75"	9.41"	19.21"	35.43"	2.76"	2.36"	7.44"	2.24"	1.65"

Head Room	Motor HP	Duty Rating in Minutes	Power Cable Length	Number of Falls	Amps	Shipping Weight lb (kg) *
18.9"	0.6	25	16'	1	9.6 / 5.3	115.0 (52.30)
22.44"	1.2	25	16'	1	13 / 10.5	154.7 (70.3)
27.95"	1.2	25	16'	2	13 / 10.5	183.6 (83.5)
31.89"	1.2	25	16'	3	13 / 10.5	216 (97.2)
35.43"	1.2	25	16'	5	13 / 10.5	283 (127.4)
18.9"	1.2	30	16'	1	2.9 / 1.7	98 (44.1)
22.44"	2.1	30	16'	1	5.8 / 3.2	138 (62.1)
27.95"	2.1	30	16'	2	5.8 / 3.2	157 (70.7)
31.89"	2.1	30	16'	3	5.8 / 3.2	205 (92.3)
35.43"	2.1	30	16'	5	5.8 / 3.2	278 (125.1)
18.9"	1.2	30	16'	1	1.4	98 (44.1)
22.44"	2.1	30	16'	1	5.8	138 (62.1)
27.95"	2.1	30	16'	2	5.8	157 (70.7)
31.89"	2.1	30	16'	3	2.6	205 (92.3)
35.43"	2.1	30	16'	5	2.6	278 (125.1)

* Shipping weights are approximate



JET

CHAIN HOISTS



 TM **10 TON**
JET L-90 SERIES CHAIN HOIST
PALAN À CHAÎNE JET SÉRIE L-90
SERIAL No. 22775



CHAIN HOISTS

VCH Series

- Triple spur geared for efficient operation
- Hardened steel roller bearings support load sheave for easy operation
- Dual pawl Weston style brake for safe reliable operation
- Exclusive premium grade, non-asbestos brake discs for longest life
- Grade 80 load chain
- Top and bottom safety hooks bend slowly to warn of overloads
- Load tested to 150% of rated capacity with certificate
- Meets ASME B30.16 standards
- ISO 9001-2000 certified factory
- **NOTE:** Custom Lifts are available in any length desired

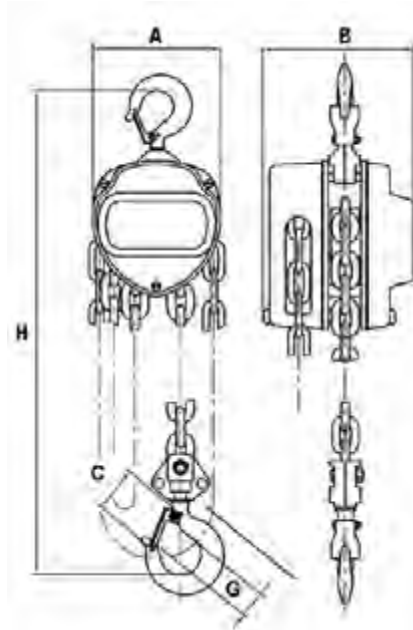

Rated Lifting Capacity (Tons)	A	B	C	G	H
1/2	4-15/16"	4-13/16"	35mm	27mm	11-1/32"
1	5-3/4"	5-1/2"	45mm	33mm	12-1/16"
2	7-1/4"	6-1/4"	52mm	33.5mm	17-1/2"

PROD. NO.	MOD. NO.	Rated Lifting Capacity (Tons)	Rated Lifting Capacity (lb)	Standard Lift
101002	VCH-0510	1/2	1,100	10'
101006	VCH-0520	1/2	1,100	20'
101012	VCH-1010	1	2,200	10'
101016	VCH-1020	1	2,200	20'
101032	VCH-2010	2	4,400	10'
101036	VCH-2020	2	4,400	20'

SAFETY HOOKS

Top and bottom safety hooks bend slowly to warn of overloads. Load tested to 150% of rated capacity with certificate.

Head Room	Number of Falls	Load Chain Diameter	Force Req. to Lift Capacity (lb)	Length of Hand Chain Pulled to Lift Load 1 ft	Shipping Weight lb (kg) *
11-1/32"	1	6.0mm	49	27'	20.3 (9.2)
11-1/32"	1	6.0mm	49	27'	31.5 (14.3)
12-1/16"	1	6.0mm	68	40'	25.1 (11.4)
12-1/16"	1	6.0mm	68	40'	36.2 (16.5)
17-1/2"	1	8.0mm	102	70'	39.5 (18)
17-1/2"	1	8.0mm	102	70'	55.7 (25.3)

* Shipping weights are approximate



CHAIN HOISTS

KCH Series - Heavy Duty

- Triple spur geared for efficient operation
- Exclusive premium grade, non-asbestos brake discs for longest life
- Grade 100 load chain for greater strength
- Top and bottom safety hooks bend slowly to warn of overloads
- Load tested to 150% of rated capacity with certificate
- Meets ASME B30.16 standards
- ISO 9001-2000 certified factory
- **NOTE: Custom lifts are available in any length desired**

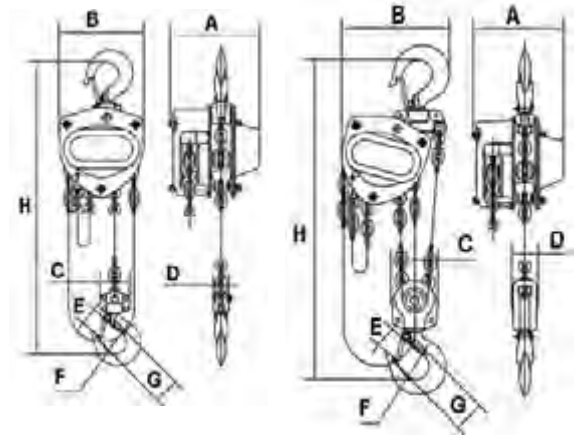

Rated Lifting Capacity (Tons)	A	B	C	D	E	F	G	H
1/2	5-1/8"	5-1/2"	1-5/8"	1"	27mm	32mm	35mm	11-1/4"
1	6-5/16"	6-5/16"	2"	1-1/8"	33mm	40mm	45mm	11-5/8"
2	7-1/4"	8"	2-1/2"	1-3/8"	37mm	46mm	52mm	14-3/4"
3	6-5/8"	9-1/4"	4-1/8"	2-1/16"	43.5mm	52mm	62.5mm	20"
5	7-1/2"	11-1/8"	2-5/8"	2-1/2"	51mm	60mm	78mm	23-5/8"

PROD. NO.	MOD. NO.	Rated Lifting Capacity (Tons)	Rated Lifting Capacity (lb)	Standard Lift	Head Room	Number of Falls	Load Chain Diameter
101102	KCH-0510	1/2	1,100	10'	11-1/4"	1	5.0mm
101106	KCH-0520	1/2	1,100	20'	11-1/4"	1	5.0mm
101112	KCH-1010	1	2,200	10'	11-5/8"	1	6.3mm
101116	KCH-1020	1	2,200	20'	11-5/8"	1	6.3mm
101132	KCH-2010	2	4,400	10'	14-3/4"	1	8.0mm
101136	KCH-2020	2	4,400	20'	14-3/4"	1	8.0mm
101142	KCH-3010	3	6,600	10'	20"	2	7.1mm
101146	KCH-3020	3	6,600	20'	20"	2	7.1mm
101152	KCH-5010	5	11,000	10'	23-5/8"	2	9.0mm
101156	KCH-5020	5	11,000	20'	23-5/8"	2	9.0mm
101162	KCH-10010	10	22,000	10'	29-15/16"	3	10.0mm
101172	KCH-15010	15	33,000	10'	39-3/8"	6	9.0mm



Maintenance free sealed bearings reduce operator effort



Dual pawl Weston style brake with extra heavy pawl springs for safe reliable operation



Extra thick ratchet gear protects brake disc from contamination



Cast safety latches exceed industry standards

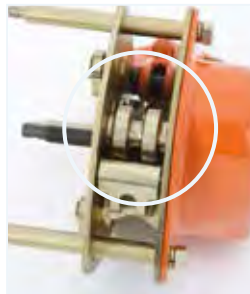

Specialized finish on key internal parts for superior corrosion resistance



Force Req. to Lift Capacity (lb)	Length of Hand Chain Pulled to Lift Load 1 ft	Shipping Weight lb (kg) *
51	25'	19.9 (9)
51	25'	29.1 (13)
64	43'	28.8 (13.1)
64	43'	40.7 (18.5)
79	70'	45.2 (20.6)
79	70'	60.6 (27.6)
79	114'	53.7 (24.4)
79	114'	73.6 (33.5)
83	198'	93.6 (42.6)
83	198'	122.2 (55.6)
90	384.6'	172 (78)
82	602.4'	315 (143)

* Shipping weights are approximate



Complete with Overload Protection

KCH SERIES WITH OVERLOAD PROTECTION

KCH Series - Heavy Duty

- KCH Series is equipped with an automatic overload protection device as standard equipment
- Device is factory preset to prevent serious overload of the hoist
- Actuation is automatic, requiring no input from the operator
- Triple Spur geared for efficient operation
- Grade 100 load chain for greater strength
- Exclusive premium grade, non-asbestos brake discs for longest life
- Load tested to 150% of rated capacity with certificate
- Meets ASME B30.16 standards
- ISO 9001-2000 certified factory
- Note: Custom lifts are available in any length desired
- **NOTE: Custom lifts are available in any length desired**

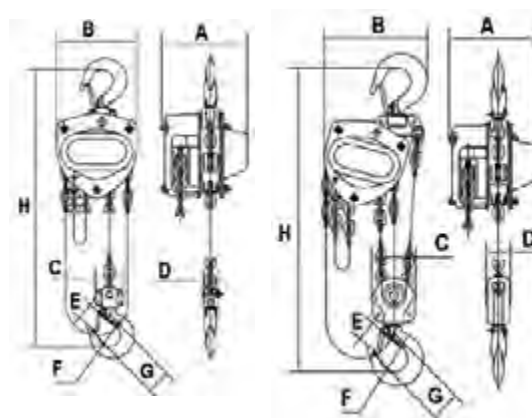

Rated Lifting Capacity (Tons)	A	B	C	D	E	F	G	H
1/2	5-1/8"	5-1/2"	1-5/8"	1"	27mm	32mm	35mm	11-1/4"
1	6-5/16"	6-5/16"	2"	1-1/8"	33mm	40mm	45mm	11-5/8"
2	7-1/4"	8"	2-1/2"	1-3/8"	37mm	46mm	52mm	14-3/4"
3	6-5/8"	9-1/4"	4-1/8"	2-1/16"	43.5mm	52mm	62.5mm	20"
5	7-1/2"	11-1/8"	2-5/8"	2-1/2"	51mm	60mm	78mm	23-5/8"

PROD. NO.	MOD. NO.	Rated Lifting Capacity (Tons)	Rated Lifting Capacity (lb)	Standard Lift	Head Room	Number of Falls	Load Chain Diameter
101302	KCH-0510L	1/2	1,100	10'	11-1/4"	1	5.0mm
101306	KCH-0520L	1/2	1,100	20'	11-1/4"	1	5.0mm
101312	KCH-1010L	1	2,200	10'	11-5/8"	1	6.3mm
101316	KCH-1020L	1	2,200	20'	11-5/8"	1	6.3mm
101332	KCH-2010L	2	4,400	10'	14-3/4"	1	8.0mm
101336	KCH-2020L	2	4,400	20'	14-3/4"	1	8.0mm
101342	KCH-3010L	3	6,600	10'	20"	2	7.1mm
101346	KCH-3020L	3	6,600	20'	20"	2	7.1mm
101352	KCH-5010L	5	11,000	10'	23-5/8"	2	9.0mm
101356	KCH-5020L	5	11,000	20'	23-5/8"	2	9.0mm



KCH SERIES WITH OVERLOAD PROTECTION



Maintenance free sealed bearings reduce operator effort



Dual pawl Weston style brake with extra heavy pawl springs for safe reliable operation



Extra thick ratchet gear protects brake disc from contamination



Cast safety latches exceed industry standards

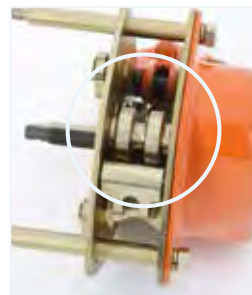

Specialized finish on key internal parts for superior corrosion resistance



OLP device for increased operator safety

Force Req. to Lift Capacity (lb)	Length of Hand Chain Pulled to Lift Load 1 ft	Shipping Weight lb (kg) *
51	25'	19.9 (9)
51	25'	29.1 (13)
64	43'	28.8 (13.1)
64	43'	40.7 (18.5)
79	70'	45.2 (20.6)
79	70'	60.6 (27.6)
79	114'	53.7 (24.4)
79	114'	73.6 (33.5)
83	198'	93.6 (42.6)
83	198'	122.2 (55.6)

* Shipping weights are approximate



CHAIN HOISTS

L-90 Series – Super Heavy Duty

- Exclusive grade 105 is the world's strongest load chain
- Provides unparalleled safety for the most demanding applications
- Chrome Molybdenum load gears for maximum strength and resistance to shock
- Load sheave is designed for long wear with uniform pockets for correct chain contact
- Drop forged hooks are designed to bend slowly to warn of overloads
- Rolled edge on hand wheel cover acts as a chain guide and allows smooth operation even when pulling the hand chain at an angle
- Positive ratchet, screw and disc are completely enclosed to protect the brake mechanism
- Non-asbestos wet friction brake discs will not slip even when oil is present
- Electrostatic powder coated before assembly to protect against rust and corrosion
- Capacity unaffected by temperatures up to -40°C with suitable winter lubrication
- Tested to 150% of rated capacity
- Meets OSHA and ANSI B30.16 standards (certificate included)
- Made in Japan

NOTE: Custom lifts are available in any length desired.



STRONGEST
LOAD CHAIN
IN THE WORLD

PROD. NO.	MOD. NO.	Rated Lifting Capacity (Tons)	Rated Lifting Capacity (lb)	Standard Lift
101202	L90-0502	1/2	1,100	10'
101204	L90-0504	1/2	1,100	15'
101206	L90-0506	1/2	1,100	20'
101212	L90-1002	1	2,200	10'
101214	L90-1004	1	2,200	15'
101216	L90-1006	1	2,200	20'
101222	L90-1502	1-1/2	3,520	10'
101224	L90-1504	1-1/2	3,520	15'
101226	L90-1506	1-1/2	3,520	20'
101232	L90-2002	2	4,400	10'
101234	L90-2004	2	4,400	15'
101236	L90-2006	2	4,400	20'
101252	L90-3002	3	6,820	10'
101254	L90-3004	3	6,820	15'
101256	L90-3006	3	6,820	20'
101262	L90-5002	5	11,000	10'
101264	L90-5004	5	11,000	15'
101266	L90-5006	5	11,000	20'
101283	L90-10003	10	22,000	11-1/2"
101292	L90-15003	15	30,000	11-1/2"

Special design ensures that chain pin is protected for safety and longer life

Articulating top hook ensures proper positioning

Top and bottom hooks swivel 360° reducing load spin



Rated Lifting Capacity (Tons)	A	B	C	D	E	F	G	H	I	N
1/2	10-3/4"	6-1/8"	2-9/16"	3-9/16"	5-1/2"	1-1/8"	1-7/16"	21/32"	1/2"	1-1/32"
1	11-3/4"	6-5/16"	2-11/16"	3-5/8"	6-5/16"	1-5/16"	1-11/16"	7/8"	5/8"	1-3/16"
1-1/2	13-1/4"	6-5/8"	2-15/16"	3-11/16"	7-3/16"	1-5/16"	1-11/16"	7/8"	5/8"	1-3/16"
2	14-3/4"	7-3/16"	3-1/4"	3-15/16"	8-7/16"	1-11/16"	2-3/32"	1-1/8"	7/8"	1-1/2"
3	20-7/8"	6-5/8"	2-15/16"	3-11/16"	9-1/16"	1-15/16"	2-3/8"	1-7/16"	1-1/16"	1-3/4"
5	24-1/2"	7-1/2"	3-9/16"	3-15/16"	11-1/16"	2-9/32"	2-3/4"	1-13/16"	1-11/32"	2-1/16"
10	30-1/2"	7-1/2"	3-9/16"	3-15/16"	15-1/8"	2-15/16"	3-3/8"	2-15/16"	1-31/32"	2-3/4"
15	38-7/8"	9-1/4"	3-9/16"	5-11/16"	19-3/8"	3-13/16"	4"	3-7/64"	2-7/16"	3-3/16"

Head Room	Number of Falls	Load Chain Diameter	Force Req. to Lift Capacity (lb)	Length of Hand Chain Pulled to Lift Load 1 ft	Shipping Weight lb (kg) *
10-3/4"	1	5.0mm	59	29'	22.7 (10.3)
10-3/4"	1	5.0mm	59	29'	27.2 (12.4)
10-3/4"	1	5.0mm	59	29'	33.8 (15.4)
11-3/4"	1	6.3mm	69	50'	29.4 (13.4)
11-3/4"	1	6.3mm	69	50'	34 (15.4)
11-3/4"	1	6.3mm	69	50'	40.5 (18.4)
13-1/4"	1	7.1mm	91	60'	36.2 (16.5)
13-1/4"	1	7.1mm	91	60'	42.9 (19.5)
13-1/4"	1	7.1mm	91	60'	49.5 (22.5)
14-3/4"	1	8.0mm	88	77'	49.6 (22.5)
14-3/4"	1	8.0mm	88	77'	56.9 (25.9)
14-3/4"	1	8.0mm	88	77'	63.5 (28.9)
20-7/8"	2	7.1mm	104	120'	58 (26.4)
20-7/8"	2	7.1mm	104	120'	68.8 (31.3)
20-7/8"	2	7.1mm	104	120'	77.6 (35.3)
24-1/2"	2	9.0mm	106	190'	96.7 (43.9)
24-1/2"	2	9.0mm	106	190'	109.9 (49.9)
24-1/2"	2	9.0mm	106	190'	125.3 (56.9)
30-1/2"	4	9.0mm	116	385'	199.2 (90.6)
38-7/8"	6	9.0mm	88	556'	41.4 (18.8)

* Shipping weights are approximate



CHAIN HOISTS

L-95 Series (Overload Protect) – Super Heavy Duty

- Series L-95 is equipped with an automatic overload protection device as standard equipment
- Overload protection is pre-set at 120% of rated capacity
- Exclusive grade 105 is the world's strongest load chain
- Provides unparalleled safety for the most demanding applications
- Chrome Molybdenum load gears for maximum strength and resistance to shock
- Load sheave is designed for long wear with uniform pockets for correct chain contact
- Sealed bearings support load and reduce operator effort
- Drop forged hooks are designed to bend slowly to warn of overloads
- Rolled edge on hand wheel cover acts as a chain guide and allows smooth operation even when pulling the hand chain at an angle
- Dual pawl brake is completely enclosed to protect the brake mechanism
- Non-asbestos wet friction brake discs will not slip even when oil is present
- Electrostatic powder coated before assembly to protect against rust and corrosion
- Tested to 150% of rated capacity
- Meets OSHA and ANSI B30.16 standards (certificate included)
- Made in Japan
- **Note: Custom lifts are available in any length desired**



Articulating top hook ensures proper positioning

Complete with overload protection

STRONGEST
LOAD CHAIN
IN THE WORLD

Special design ensures that chain pin is protected for safety and longer life



Top and bottom hooks swivel 360° reducing load spin



PROD. NO.	MOD. NO.	Rated Lifting Capacity (Tons)	Rated Lifting Capacity (lb)	Standard Lift
101402	L95-0502	1/2	1,100	10'
101406	L95-0506	1/2	1,100	20'
101412	L95-1002	1	2,200	10'
101416	L95-1006	1	2,200	20'
101422	L95-1502	1-1/2	3,520	10'
101426	L95-1506	1-1/2	3,520	20'
101432	L95-2002	2	4,400	10'
101436	L95-2006	2	4,400	20'
101452	L95-3002	3	6,820	10'
101456	L95-3006	3	6,820	20'
101462	L95-5002	5	11,000	10'
101466	L95-5006	5	11,000	20'

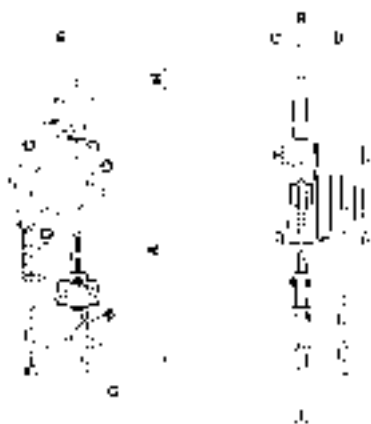

1/2 Ton - 2 Tons



3 Tons, 5 Tons

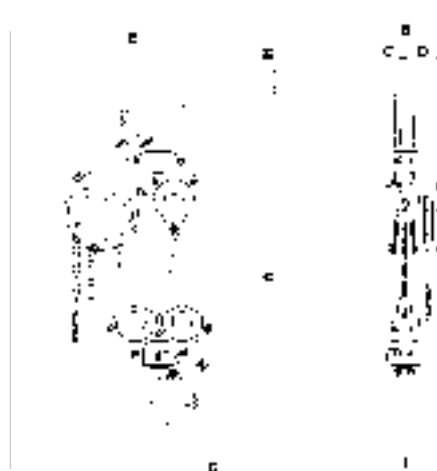

10 Tons, 15 Tons

Rated Lifting Capacity (Tons)	A	B	C	D	E	F	G	H	I	N
1/2	10-3/4"	6-1/8"	2-9/16"	3-9/16"	5-1/2"	1-1/8"	1-7/16"	21/32"	1/2"	1-1/32"
1	11-3/4"	6-5/16"	2-11/16"	3-5/8"	6-5/16"	1-5/16"	1-11/16"	7/8"	5/8"	1-3/16"
1-1/2	13-1/4"	6-5/8"	2-15/16"	3-11/16"	7-3/16"	1-5/16"	1-11/16"	7/8"	5/8"	1-3/16"
2	14-3/4"	7-3/16"	3-1/4"	3-15/16"	8-7/16"	1-11/16"	2-3/32"	1-1/8"	7/8"	1-1/2"
3	20-7/8"	6-5/8"	2-15/16"	3-11/16"	9-1/16"	1-15/16"	2-3/8"	1-7/16"	1-1/16"	1-3/4"
5	24-1/2"	7-1/2"	3-9/16"	3-15/16"	11-1/16"	2-9/32"	2-3/4"	1-13/16"	1-11/32"	2-1/16"
10	30-1/2"	7-1/2"	3-9/16"	3-15/16"	15-1/8"	2-15/16"	3-3/8"	2-15/16"	1-31/32"	2-3/4"
15	38-7/8"	9-1/4"	3-9/16"	5-11/16"	19-3/8"	3-13/16"	4"	3-7/64"	2-7/16"	3-3/16"

Head Room	Number of Falls	Load Chain Diameter	Force Req. to Lift Capacity (lb)	Length of Hand Chain Pulled to Lift Load 1 ft	Shipping Weight lb (kg) *
10-3/4"	1	5.0mm	49	29'	22.6 (10.3)
10-3/4"	1	5.0mm	49	29'	33.7 (15.3)
11-3/4"	1	6.3mm	56	50'	29.3 (13.3)
11-3/4"	1	6.3mm	56	50'	40.4 (18.4)
13-1/4"	1	7.1mm	75	60'	36.2 (16.5)
13-1/4"	1	7.1mm	75	60'	51.6 (23.5)
14-3/4"	1	8.0mm	73	77'	51.9 (23.6)
14-3/4"	1	8.0mm	73	77'	66.2 (30.1)
20-7/8"	2	7.1mm	77	120'	56 (25.2)
20-7/8"	2	7.1mm	77	120'	79.7 (36.2)
24-1/2"	2	9.0mm	77	190'	97 (43.7)
24-1/2"	2	9.0mm	77	190'	128.4 (58.4)

* Shipping weights are approximate

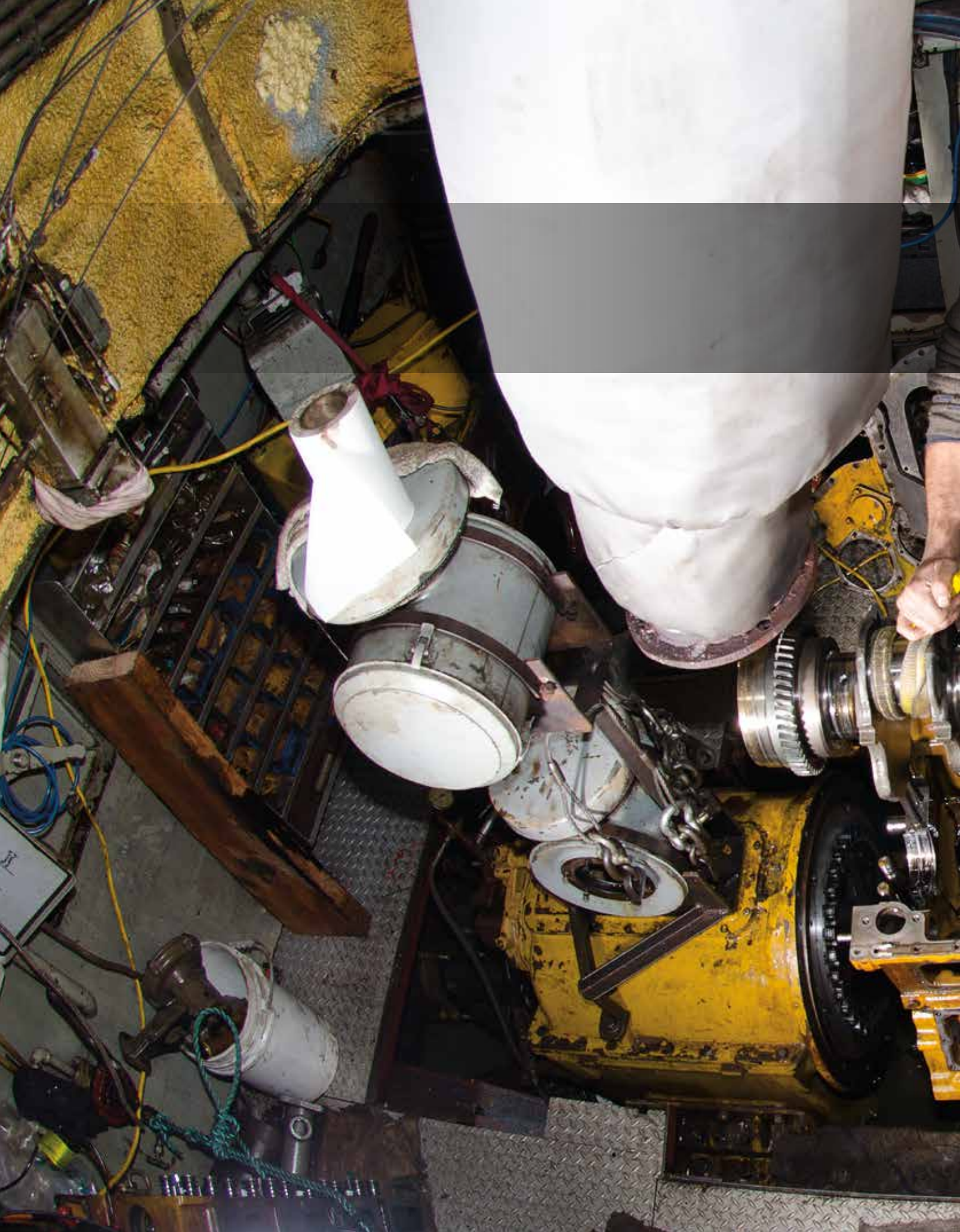

LEVER CHAIN PULLERS



LEVER CHAIN PULLERS

SUMO® Series

- Light weight design combines versatility with economy
- Load tested to 150% of rated capacity
- Meets ANSI B30.21 specifications (Certificate included)
- Special heavy-duty, long-lasting brake pads – last up to five times longer than competitive brands
- Stamped steel housing protects gears and brake mechanism from damage
- Galvanized chain, hub, lever switch and inside plates
- Completely repairable with easy access for maintenance; parts and service are readily available
- Two coats of high visibility safety yellow protective coating
- Short lever length allows for easier access into confined work areas
- High quality load chain meets all international safety standards
- All hooks have safety latches as an additional safety feature and are designed to bend slowly rather than fracture under overload conditions



E06961



SLP-25

SLP-50

PROD. NO.	MOD. NO.	A	B	C	D	E	F	G	H	J
E06961	SLP-25	8-5/8"	3-5/8"	2-1/4"	7/8"	2-3/4"	3-1/4"	6"	15/16"	3/4"
E06962	SLP-50	11-3/8"	4-5/16"	3	1	3-1/4"	4-7/16"	11-1/4"	1-3/16"	3/4"

PROD. NO.	MOD. NO.	Rated Lifting Capacity (Tons)	Standard Lift	Min Distance Between Hooks	Distance per Handle Pull	Force Req. to Lift Capacity (lb)	Lever Length	Shipping Weight lb (kg) *
E06961	SLP-25	1/4	5'	9-5/8"	2"	66	6"	14.3 (6.5)
E06962	SLP-50	1/2	5'	11-3/8"	1-3/64"	81	11-1/4"	22 (10)

* Shipping weights are approximate

VLP Series

- Cold formed stamped steel housings resist impact
- Grade 80 load chain
- Hardened steel roller bearings support load for easier operation
- Dual pawl Weston style brake for reliable and safe operation
- Exclusive premium grade, non-asbestos brake discs for longest life
- Top and bottom safety hooks bend to warn of overloads
- Deformation indicators on hooks allow accurate measurement for easy maintenance
- Load tested to 150% of rated capacity (with certificate)
- Meets ASME B30.21 standards
- ISO 9001-2000 certified factory
- **NOTE: Custom lifts are available in any length desired**



PROD. NO.	MOD. NO.	A	B	C	D	H
110302	VLP-75	5-7/8"	3-1/2"	37.5mm	12"	12-3/4"
110303	VLP-150	6-3/4"	3-7/8"	47mm	16-1/2"	15"
110304	VLP-300	7-7/8"	4-1/2"	62.5mm	16-1/2"	18-7/8"

PROD. NO.	MOD. NO.	Rated Lifting Capacity (Tons)	Standard Lift	Number of Falls	Load Chain Diameter	Min Distance Between Hooks	Force Req. to Lift Capacity (lb)	Lever Length	Shipping Weight lb (kg) *
110302	VLP-75	3/4	5'	1	6.0mm	12"	31	12"	14 (6.4)
110303	VLP-150	1-1/2	5'	1	8.0mm	15"	48	16-1/2"	27.4 (12.5)
110304	VLP-300	3	5'	1	10.0mm	18-7/8"	70	16-1/2"	45.7 (20.8)

* Shipping weights are approximate



LEVER CHAIN PULLERS

KLP Series – Heavy Duty

- High impact gear case and brake cover for heavy duty service
- Grade 100 load chain for greater strength
- Exclusive premium grade, non-asbestos brake discs for longest life
- Top and bottom safety hooks bend to warn of overloads
- Cast steel safety latches exceed industry standards
- Meets ASME B30.21 standards
- ISO 9001-2000 certified factory
- **NOTE: Custom lifts are available in any length desired.**



Caged ball bearings on load sprocket for the ultimate in smooth, easy operation



Dual pawl Weston style brake features extra heavy pawl springs for reliable and safe operation



Deformation indicators on hooks allow accurate measurement for easy maintenance

Load tested to 150% of rated capacity (with certificate)

PROD. NO.	MOD. NO.	Rated Lifting Capacity (Tons)	Standard Lift	Number of Falls	Load Chain Diameter	Min Distance Between Hooks	
NEW	110803	KLP-25-5	1/4	5'	1	3.2mm	7.87"
NEW	110804	KLP-50-5	1/2	5'	1	4.3mm	9.84"
	110402	KLP-75-5	3/4	5'	1	5.6mm	11"
	110406	KLP-75-10	3/4	10'	1	5.6mm	11"
	110403	KLP-150-5	1-1/2	5'	1	7.1mm	13-3/4"
	110407	KLP-150-10	1-1/2	10'	1	7.1mm	13-3/4"
	110404	KLP-300-5	3	5'	1	10.0mm	16-1/2"
	110408	KLP-300-10	3	10'	1	10.0mm	16-1/2"
	110405	KLP-600-5	6	5"	2	10.0mm	22-7/16"

WITH OVERLOAD PROTECTION



PROD. NO.	MOD. NO.	Rated Lifting Capacity (Tons)	Rated Lifting Capacity (lb)	Standard Lift	Number of Falls	Load Chain Diameter	Head Room
110412	KLP-75-5L	3/4	1,650	5'	1	5.6mm	11"
110413	KLP-150-5L	1-1/2	3,300	5'	1	7.1mm	13-3/4"
110414	KLP-300-5L	3	6,600	5'	1	10.0mm	16-1/2"

Overload Protection for KLP Series

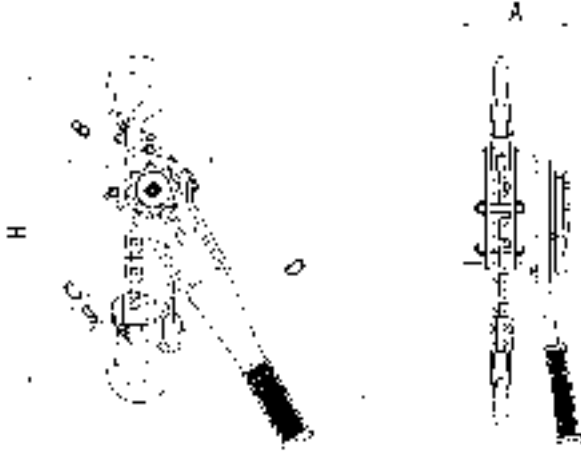

MODEL NO.	A	B	C	D	G	H
KLP-75	5-13/16"	3-1/2"	37.5mm	10-1/2"	28mm	11"
KLP-150	6-1/2"	4-1/4"	47mm	16-1/2"	33.5mm	13-3/4"
KLP-300	7-11/16"	4-1/2"	62.5mm	16-1/4"	43.5mm	16-1/2"
KLP-600	7-11/16"	4-1/2"	78mm	16-1/4"	-	22-7/16"

Force Req. to Lift Capacity (lb)	Lever Length	Shipping Weight lb (kg) *
44	5-7/10"	3.75 (1.7)
52.8	6-3/10"	5.95 (2.7)
42	10-1/2"	14 (6.4)
42	10-1/2"	16 (7.3)
46	16-1/2"	22.8 (10.4)
46	16-1/2"	24.3 (11)
68	16-1/2"	39.7 (18)
68	16-1/2"	38 (17.2)
81	16-1/2"	61 (27.7)

Force Req. to Lift Capacity (lb)	Length of Hand Chain Pulled to Lift Load 1 ft	Shipping Weight lb (kg) *
42	10-1/2"	15 (6.75)
46	16-1/4"	23 (10)
68	16-1/4"	36 (16)

* Shipping weights are approximate





LEVER CHAIN PULLERS

Mini-Mite II Series – Super Heavy Duty

- Exclusive grade 105 load chain is the world's strongest grade
- Allows use of smaller load chain without compromising safety
- Zinc coated load chain and coated brake hub minimize corrosion
- One simple lever changes direction and disengages gear train for fast chain adjustments
- New larger hooks with extra heavy duty latches
- Riveted rubber handle for comfort and safety
- Electrostatic powder painted before assembly to protect against rust
- Capacity unaffected at temperatures up to -40°C with suitable winter lubrication
- Tested to 150% of rated capacity
- Meets ANSI B30.21 specifications (certificate included)
- Made in Japan
- **Note: Custom lifts are available in any length desired**

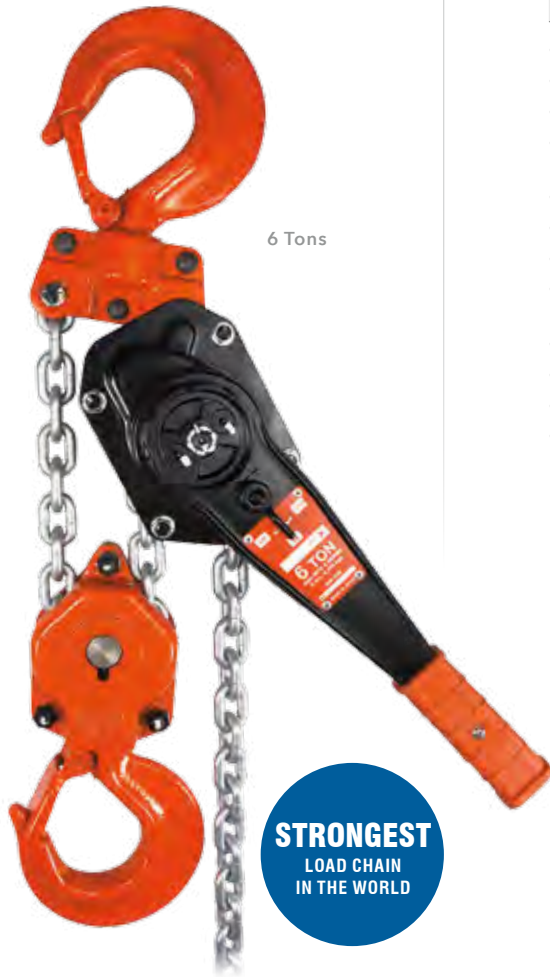

6 Tons

STRONGEST
LOAD CHAIN
IN THE WORLD

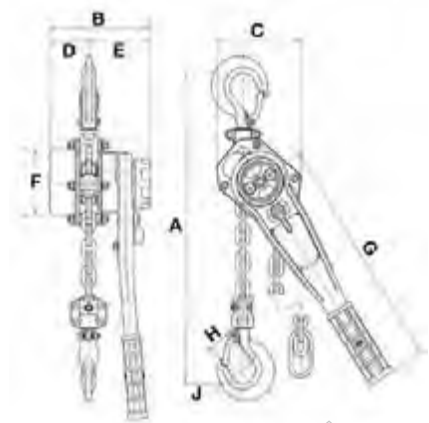

Rated Lifting Capacity (Tons)	A	B	C	D	E	F	G	H	J
1/4	9-1/4"	3-5/8"	2-1/4"	7/8"	2-3/4"	3-1/4"	6-1/8"	15-16"	3/4"
1/2	10-7/16"	4-5/16"	3"	1"	3-1/4"	4-7/16"	11-3/16"	1-3/16"	3/4"
3/4	11-7/16"	5-5/8"	4-13/16"	2-1/16"	3-9/16"	4-11/32"	10-1/2"	29/32"	1-13/32"
1-1/2	13-7/8"	6-3/8"	5-5/16"	2-1/2"	3-7/8"	4-1/2"	12-3/16"	1-9/64"	1-11/16"
3	16-3/16"	7-11/32"	7-3/32"	3-1/4"	4-3/32"	6-5/8"	14-3/16"	1-13/32"	2-5/64"
6	22-13/64"	7-11/32"	9-1/4"	3-1/4"	4-3/32"	6-5/8"	14-3/16"	1-27/32"	2-3/4"

PROD. NO.	MOD. NO.	Rated Lifting Capacity (Tons)	Standard Lift	Number of Falls	Load Chain Diameter
110903	MM-25	1/4	3'3"	1	4.2mm
110904	MM-50	1/2	5'	1	5.0mm
110506	MM80-5	3/4	5'	1	5.6mm
110507	MM80-10	3/4	10'	1	5.6mm
110509	MM160-5	1-1/2	5'	1	7.1mm
110510	MM160-10	1-1/2	10'	1	7.1mm
110512	MM320	3	5'	1	9.0mm
110513	MM320	3	10'	1	9.0mm
110515	MM630	6	5'	2	9.0mm



1/4 Ton



1/2 Ton



1-1/2 Tons



3 Tons

Min Distance Between Hooks	Distance per Handle Pull	Force Req. to Lift Capacity (lb)	Lever Length	Shipping Weight lb (kg) *
9-1/4"	2"	61	6-1/8"	4.8 (2.2)
10-1/4"	1-3/64"	75	11-1/4"	9 (4.1)
11-7/16"	1-3/16"	66	10-1/2"	15.2 (6.9)
11-7/16"	1-3/16"	66	10-1/2"	16.8 (7.6)
13-7/8"	1"	66	12-3/16"	22.4 (10.2)
13-7/8"	1"	66	12-3/16"	26.1 (11.9)
16-3/16"	1/2"	82	14-3/16"	36.9 (16.8)
16-3/16"	1/2"	82	14-3/16"	38 (17.2)
22-13/64"	3/8"	84	14-3/16"	64.5 (29.3)

* Shipping weights are approximate



LEVER CHAIN PULLERS

#10-2 Series – Super Heavy Duty

- The toughest lever chain hoist made
- High tensile strength cast steel housing protects gears from impact damage
- Cast steel handle provides maximum strength and leverage
- Simple design makes routine inspection or maintenance fast and easy
- Non-asbestos brake discs use a high quality low abrasion aramid fibre material for a safer and healthier environment
- Easy free wheeling system automatically returns to hoisting mode when load is applied
- High grade low-wear chain is strong and smooth finished to prevent snagging or jamming
- Gauge included to check for chain elongation and hook stretch
- Top and bottom safety hooks are standard, and are designed to bend slowly to warn of overloads
- Each unit is tested to 150 % of rated capacity
- Meets ANSI B30.21 Standards (Certificate included)
- Made in Japan
- **NOTE: Custom Lifts are available in any length desired**



PROD. NO.	MOD. NO.	A	B	C	D
110241	#10-2	12-3/8"	8-9/16"	2-15/32"	3-1/2"
110242	#10-2	14-15/16"	10-21/64"	2-61/64"	4-3/32"
110243	#10-2	18-7/8"	12-3/4"	3-11/16"	5-3/16"
110244	#10-2	23-7/8"	15-3/32"	3-11/16"	6-15/32"

PROD. NO.	MOD. NO.	Rated Lifting Capacity (Tons)	Standard Lift	Number of Falls
110241	#10-2	3/4	5'	1
110242	#10-2	1-1/2	5'	1
110243	#10-2	3	5'	1
110244	#10-2	6	5'	2

Articulating top hook ensures proper positioning

Top and bottom hooks swivel 360° reducing load spin



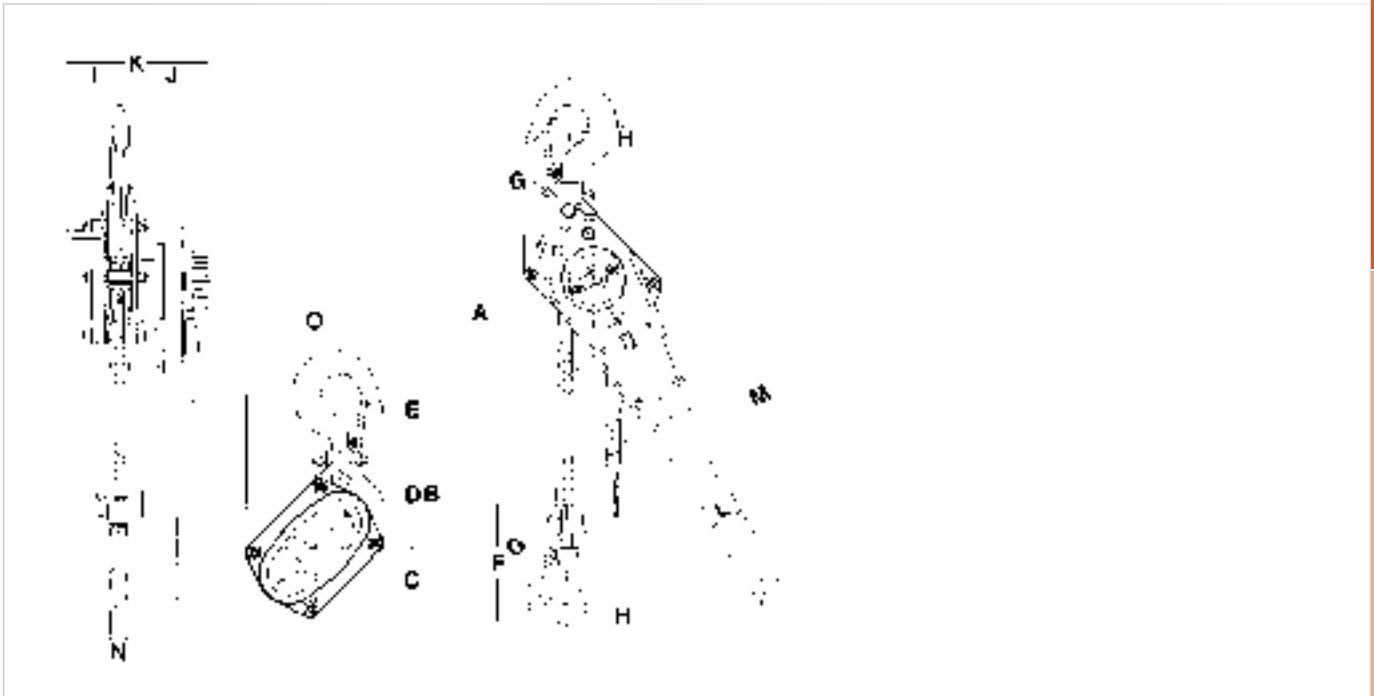

E	F	G	H	I	J	K	L	M	N	O
2-19/32"	3-63/64"	61/64"	1-3/8"	2-3/16"	4-15/64"	6-27/64"	1-3/16"	10-1/2"	37/64"	4-59/64"
3-17/64"	5-3/64"	1-19/64"	1-21/32"	2-41/64"	4-7/32"	6-27/32"	1-3/8"	16-1/16"	25/32"	5-29/32"
3-7/8"	6-5/16"	1-19/32"	1-31/32"	3-17/32"	4-1/2"	8-1/32"	1-3/8"	16-1/16"	1"	7-3/8"
4-15/16"	10-21/32"	1-27/32"	2-17/32"	3-17/32"	4-1/2"	8-1/32"	1-3/8"	16-1/16"	1-3/8"	10-21/32"

Load Chain Diameter	Min Distance Between Hooks	Distance per Handle Pull	Force Req. to Lift Capacity (lb)	Lever Length	Shipping Weight lb (kg) *
5.6mm	12-3/8"	1-1/16"	66	10-1/2"	22.3 (10.1)
7.1mm	14-15/16"	1-1/8"	66	16-1/16"	28 (12.7)
9.0mm	18-7/8"	3/4"	84	16-1/16"	44 (20)
9.0mm	23-7/8"	3/8"	84	16-1/16"	74.6 (34)

* Shipping weights are approximate

Special design ensures chain pin is protected for safety and longer life



Offset handle protects operator





WIRE ROPE PULLERS

SGP Series – Heavy Duty

- Compact high strength steel housing
- Light weight, simple and safe to operate
- May be used in any position to lift, pull, lower, or stretch heavy loads
- The rope clamp system is easily disengaged with a lever, allowing smooth installation of the wire rope
- Overload protection is built-in with a shear pin in the forward lever, which will break when overloaded. The broken pins can be replaced without removing the load and spare shear pins are conveniently located in the rubber sleeve of the telescopic handle for SGP-75A and in the carrying handle for the SGP-150A and SGP-300A
- The design enables wire rope to be fed through 2 sets of wear resistant interlocking jaws by a single operating lever
- The SGP Wire Rope Pulling Hoist has a parallel clamping system, which has a large surface contact area, providing an evenly distributed grip at a lower force that results in less rope wear and maximum safety. The system offers a longer rope advance and requires less handle pulling effort, thus increasing operator efficiency
- All SGP Wire Rope Pulling Hoists are tested and have individual serial numbers for easy traceability to a test certificate (included)
- Uses standard ASA and IWRC wire rope (not included)

PROD. NO.	MOD. NO.	Rated Lifting Capacity (Tons)	Rated Lifting Capacity (lb)	Rated Pulling Capacity (Tons)	Rated Pulling Capacity (lb)	Dimensions L x W x H	Standard Wire Rope Diameter	Operating Rope Advance	Effort at Rated Load (lb)	Telescopic Handle Length	Shipping Weight lb (kg) *
111136	SGP-75A	3/4	1,760	1.4	2,860	16-3/4" x 2-1/2" x 9"	5/16"	2.36"	64	29"	39.7 (18)
111137	SGP-150A	1-1/2	3,520	2.8	5,720	21-1/2" x 3-3/4" x 10-1/4"	7/16"	2.36"	93	44"	45.2 (20.5)
111138	SGP-300A	3	7,040	5.7	11,440	26" x 4-1/2" x 12-1/2"	5/8"	1.57"	99	44"	71.6 (32.5)



Unique reusable reel allows safe, convenient storage of wire rope



Cable Assemblies for Wire Rope Pullers

- Wire rope for JET / SGP Series grip pullers with safety hook included
- Galvanized for longer life
- Includes reel

PROD. NO.	MOD. NO.	Wire Size	Wire Rope Length	To Fit Product No.	Shipping Weight lb (kg) *
111152	SGP-75A	5/16"	66'	11136	6.6 (3)
111153	SGP-150A	7/16"	66'	11137	27.7 (12.6)
111154	SGP-300A	5/8"	66'	11138	54.7 (24.8)
111162	SGP-75A	5/16"	100'	11136	25.5 (11.6)
111163	SGP-150A	7/16"	100'	11137	28.3 (12.9)

* Shipping weights are approximate

HAND CABLE PULLERS



- One piece heavy duty frame is zinc plated and polished to resist corrosion
- Hook swivel block attached to double reinforced yoke for maximum strength
- Top hook bracket drop forged for maximum strength
- Drop forged steel hooks complete with safety latches
- Automatic safety system allows load to be released one notch at a time
- Heavy duty steel safety shield



JCPP Series – Heavy Duty **111225** / JCPP-200

- Heavy duty solid steel ratchet pawl and holding dog
- 14" heavy duty polished ratchet arm with ergonomic grip for operator comfort and ease of use
- Heavy duty aircraft cable, 12' length, 3/16" diameter
- Pulling capacity 2 tons, lifting capacity 1 ton



JCPP Series – Super Heavy Duty **111228** / JCPP-400

- Two heavy duty solid steel ratchet pawls for maximum strength and safety
- 18" heavy duty polished ratchet arm with ergonomic grip for operator comfort and ease of use
- Heavy duty aircraft cable, 10' length, 1/4" diameter
- Pulling capacity 4 tons, lifting capacity 2 tons

PROD. NO.	MOD. NO.	Rated Pulling Capacity (Tons)	Rated Lifting Capacity (Tons)	Number of Pawls	Number of Hooks	Maximum Cable Length	Shipping Weight lb (kg) *
111225	JCPP-200	2	1	1	2	5' @ 2 tons	8.8 (4)
111228	JCPP-400D	4	2	2	3	10' @ 2 tons, 5' @ 4 tons	16.5 (7.5)

Double reinforced yoke for strength and safety

Drop forged and plated hanging bracket swivel for strength and safety

Solid steel ratchet wheel and holding pawl

Drop forged steel hook complete with safety latch

Ergonomic handle



Recreational



Emergency



Industrial



Fencing



* Shipping weights are approximate



TROLLEYS AND CLAMPS



JET
MOD. NO. JBC-3
PROD. NO. 120606
SER. NO.
CAPACITY/CAPACITE
3 TON

JBC Series – Heavy Duty

- Can be used for suspending loads or inverted as a clamp for vertical lifting of flanged beams
- Jaw design reduces stress on beam flanges by distributing load away from edges
- Equal width jaws assure best possible stability
- Threaded handle allows for ease of installation and portability
- Special locking screw mechanism ensures the unit stays tight, increasing safety
- Can be adjusted to fit securely on a wide range of flange and beam widths
- Built-in suspension bar provides ultra low headroom
- Meets ANSI B30.11 and B30.20 specifications (certificate included)
- Tested to 150% of rated capacity
- Maximum angle from vertical 15° when used for lifting beams

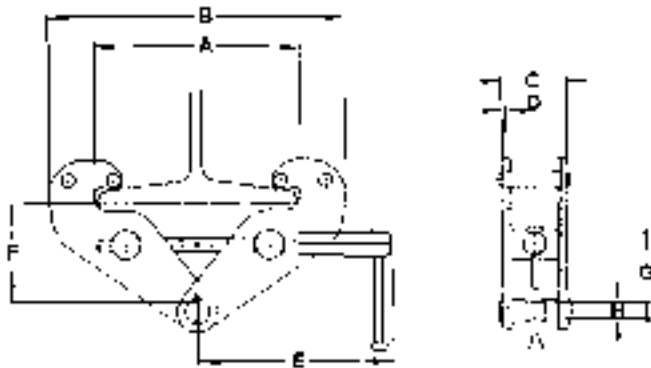

Locking screw prevents accidental loosening of clamp jaws

PROD. NO.	MOD. NO.	Maximum A	Minimum B	Maximum B	C	D	E	Maximum F	Minimum F	Minimum G	H
120603	JBC-1	9.65"	7.48"	14.17"	2.76"	.20"	8.46"	5.31"	3.07"	1.10"	.80"
120605	JBC-2	9.65"	7.48"	14.17"	2.91"	.28"	8.46"	5.31"	3.07"	1.10"	.80"
120606	JBC-3	11.22"	9.84"	17.52"	4.65"	.31"	10.24"	6.30"	4.33"	2.17"	.87"
120607	JBC-5	12.60"	10.43"	19.09"	5.51"	.39"	10.63"	6.50"	4.92"	2.05"	1.10"

PROD. NO.	MOD. NO.	Capacity (Tons)	Rated Capacity (lb)	Rated Flange Width	Shipping Weight lb (kg) *
120603	JBC-1	1	2,000	2.95" - 9.05"	13 (5.9)
120605	JBC-2	2	4,000	2.95" - 9.05"	15.2 (7)
120606	JBC-3	3	6,000	3.35" - 11"	28.8 (13.1)
120607	JBC-5	5	10,000	3.5" - 12"	38 (17.3)

* Shipping weights are approximate



MANUAL TROLLEYS

SGT Series Geared – Heavy Duty

- Geared wheels driven by hand chain for precise load control
- 10' hand chain drop
- Double sealed ball bearings for long life
- Specially hardened steel wheels meet ANSI B30.11 specifications (certificate included)
- Specially designed integrated drop stops/bumpers take the load in the event of wheel failure and prevent wheels from contacting other trolleys on the track
- Adjustable to fit various sizes of flanges and beams
- Comes equipped for use on up to 8" beam widths
- Can be installed or removed at any point along the track
- Use on straight or curved H, I, W and S-beams



A	B	C	D	E	F	G
13-1/8"	10-1/4"	9-3/8"	2-15/16"	1-1/4"	1/8"	5-13/64"
13-29/32"	11-7/8"	10-15/16"	3-1/2"	1-1/16"	1/8"	6-1/16"
14-5/8"	13-1/2"	13-15/16"	4-5/16"	13/16"	1/8"	7-21/32"
15-15/32"	15-3/8"	15-29/32"	4-3/4"	13/16"	1/8"	8-3/4"
17-11/64"	18-1/2"	19-5/8"	5-29/32"	1-3/4"	1/8"	11"

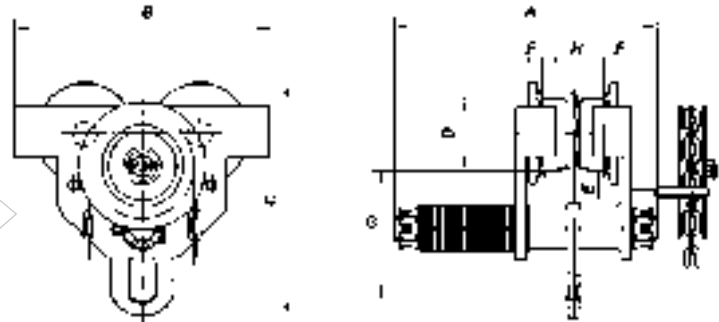

PROD. NO.	Rated Capacity (Tons)	Rated Capacity (lb)	I-Beam Flange Width (H)	Min. Radius Curve	Diameter Length of Chain	Shipping Weight lb (kg) *
120362	1	2,200	4" - 8-1/32"	40"	3/16" x 10'	43.7 (19.8)
120364	2	4,400	4" - 8-1/32"	43"	3/16" x 10'	66 (30)
120365	3	6,600	4" - 8-1/32"	51"	3/16" x 10'	109.2 (49.7)
120366	5	11,000	4-1/2" - 8-1/32"	55"	3/16" x 10'	140.8 (64)
120367	10	22,000	4-15/16" - 8-1/32"	67"	3/16" x 10'	253.4 (115.2)

* Shipping weights are approximate

SBT Series – Heavy Duty

- Load is moved by pulling on hoist load chain in direction of travel
- Double sealed ball bearings for long life
- Specially hardened steel wheels meet ANSI B30.11 specifications (certificate included)
- Specially designed integrated drop stops/bumpers take the load in the event of wheel failure and prevent wheels from contacting other trolleys on the track
- Adjustable to fit various sizes of flanges and beams
- Comes equipped for use on up to 8" beam widths
- Can be installed or removed at any point along the track
- Use on straight or curved H, I, W and S-beams



Hardened steel wheels meet ANSI B30.11 standards

8" capacity bolts for use on wider beams



Extension kits available
See below

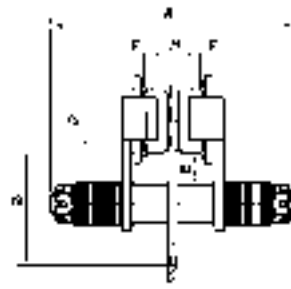

Rated Capacity (Tons)	A	B	C	D	E	F	G
1/2	12-13/32"	8-1/2"	8-1/8"	2-1/4"	1-1/4"	1/8"	4-41/64"
1	13-1/8"	10-1/4"	9-3/8"	2-15/16"	1-1/4"	1/8"	5-13/64"
1-1/2	13-15/16"	10-3/4"	10"	3-3/8"	1-1/8"	1/8"	5-1/4"
2	13-29/32"	11-7/8"	10-15/16"	3-1/2"	1-1/8"	1/8"	6-1/16"
3	14-5/8"	13-1/2"	13-15/16"	4-5/16"	13/16"	1/8"	7-21/32"
5	15-15/32"	15-3/8"	15-29/32"	4-3/4"	13/16"	1/8"	8-3/4"
10	17-11/64"	18-1/2"	19-5/8"	5-29/32"	1-1/4"	1/8"	11"

PROD. NO.	Rated Capacity (Tons)	Rated Capacity (lb)	I-Beam Flange Width (H)	Minimum Radius Curve	Shipping Weight lb (kg) *
120251	1/2	1,100	3-1/4" - 8-1/32"	36"	20.7 (9.4)
120252	1	2,200	4" - 8-1/32"	40"	34.2 (15.6)
120253	1-1/2	3,300	4" - 8-1/32"	40"	43.3 (19.7)
120254	2	4,400	4" - 8-1/32"	43"	56.5 (25.7)
120255	3	6,600	4" - 8-1/32"	51"	90.5 (41.1)
120256	5	11,000	4-1/2" - 8-1/32"	55"	124.9 (56.8)
120257	10	22,000	4-15/16" - 8-1/32"	67"	233.6 (106.1)

Extension Shaft Kits

- Converts trolleys for use on beams with flange widths from 8" to 12"
- Includes suspension shaft, washers, castle nuts and split pins
- Fits SBT and SGT series trolleys



Extra heavy duty side plates ensure strongest beam clamps available!

PROD. NO.	MOD. NO.	Description	PROD. NO.	MOD. NO.	Description
124202	JTES-0512	1/2 ton trolleys	124206	JTES-3012	3 ton trolleys
124203	JTES-1012	1 ton trolleys	124207	JTES-5012	5 ton trolleys
124204	JTES-1512	1.5 ton trolleys	124208	JTES-10012	10 ton trolleys
124205	JTES-2012	2 ton trolleys			

* Shipping weights are approximate

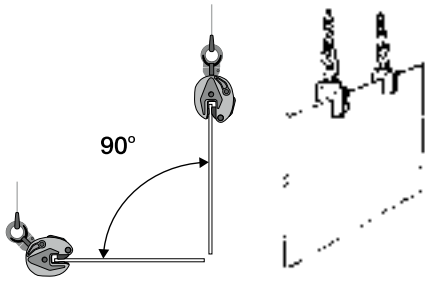

PLATE CLAMPS

- Heavy duty industrial plate clamps safely lift various sizes and weights of steel plates
- A must for all steel fabrication plants
- All units complete with safety lock
- Specially hardened jaw for long life and safe gripping power
- Suitable for plates of 400 Vickers (HRC-41) Max
- Meets ANSI B30.20 specifications (certificate included)
- Tested to 200% of rated capacity

SPC Series Vertical – Heavy Duty

- Vertical type for straight line lifting of vertically stored steel plates

PROD. NO.	MOD. NO.	Rated Lifting Capacity (Tons)	Jaw Opening	Suspension Eye Opening	Min Plate Thickness (in/mm)	Shipping Weight lb (kg) *
109302	SPC-100	1	0 - 7/8"	2"	7/32" (5.5)	7.7 (3.5)
109304	SPC-200	2	0 - 1-3/16"	2-1/4"	19/64" (7.5)	13.2 (6)
109305	SPC-300	3	0 - 1-3/8"	2-3/8"	11/32" (8.8)	23.1 (10.5)

SPCU Series Universal Style – Heavy Duty

- Universal type suitable for lifting horizontally stored plates into vertical position
- Can be used to flip plates over provided adequate ground clearance is allowed for safety lock lever to operate

PROD. NO.	MOD. NO.	Rated Lifting Capacity (Tons)	Jaw Opening	Suspension Eye Opening	Min Plate Thickness (in/mm)	Shipping Weight lb (kg) *
109322	SPCU-50	1/2	0 - 19/32"	1-1/8"	5/32" (3.8)	5.5 (2.5)
109323	SPCU-100	1	0 - 13/16"	1-7/8"	13/64" (5.0)	11.0 (5)
109325	SPCU-200	2	0 - 1"	2-1/4"	1/4" (6.3)	16.5 (7.5)
109327	SPCU-300	3	0 - 1-3/16"	3"	19/64" (7.5)	34.1 (15.5)



DRUM LIFTER

SDL Series Drum Lifter

- Designed to lift steel drums with or without lids
- Clamp uses drum edge for lifting
- Compact and lightweight
- All steel construction
- 6mm Grade 80 galvanized alloy chain
- 6:1 safety factor
- Chain length 19"

PROD. NO.	MOD. NO.	Rated Lifting Capacity (Tons)	Shipping Weight lb (kg) *
109392	SDL-100	1	7.7 (3.5)

* Shipping weights are approximate

YARDING BLOCKS



- Strong, all steel construction
- Ball bearing, high carbon steel sheave
- Quick release yoke swings open to accept rope
- Zerk type grease fitting on all sizes
- Tested to 150% of rated capacity

Single Sheave Yarding Blocks

PROD. NO.	Size	Rated Capacity (Tons)	Rope Diameter	Shipping Weight lb (kg) *
131104	4"	1	3/8"	4.4 (2)
131105	5"	1-1/2	1/2"	6.6 (3)
131106	6"	2	9/16"	11 (5)
131108	8"	4	5/8"	28.6 (13)



SNATCH BLOCKS

- Cast iron sheaves
- Powder metallurgy bushings for improved oil retention
- Hook complete with safety latch
- Side plate swings open to accept rope
- Ball type oiler on 3", 4" and 5"
- Zerk type grease fitting on 6," 8" and 10"
- Available with single or double sheave
- Tested to 150% of rated capacity

Single Sheave Snatch Blocks

PROD. NO.	Size	Rated Capacity (Tons)	Rope Diameter	Shipping Weight lb (kg) *
130103	3"	1/2	3/8"	3.4 (1.6)
130104	4"	1	7/16"	5.9 (2.7)
130105	5"	1-1/2	1/2"	10.2 (4.6)
130106	6"	2	5/8"	17.2 (7.8)
130108	8"	4	3/4"	43.5 (19.8)



Single Sheave

Double Sheave

Double Sheave Snatch Blocks

PROD. NO.	Size	Rated Capacity (Tons)	Rope Diameter	Shipping Weight lb (kg) *
130203	3"	1/2	3/8"	5.6 (2.5)
130204	4"	1	7/16"	9.3 (4.2)

SHEAVES

Single Sheaves

PROD. NO.	Size	Bore Size	Rope Diameter	Rated Capacity (Tons)	Width	Shipping Weight lb (kg) *
133103	3"	1/2"	5/16"	1/2	3/4"	1 (0.4)
133104	4"	5/8"	3/8"	1	15/16"	1.9 (0.9)
133105	5"	3/4"	1/2"	1-1/2	1-1/16"	3.6 (1.6)
133106	6"	1-1/8"	5/8"	2	1-5/16"	5.9 (2.7)
133108	8"	1-1/4"	7/8"	4	1-7/8"	14.7 (6.7)



- Cast iron
- Bronze bushings
- Ball type oiler
- Tested to 150% of rated capacity
- Not a replacement for snatch block or yarding block sheaves

* Shipping weights are approximate



HAND WINCHES

IWF Series - Super Heavy Duty



113263

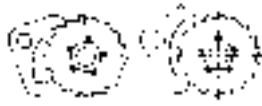

Double Brake Pawl



- Chain hoist type dual pawl Weston brake for ultimate load control
- All braking components are plated with a rust resistant finish
- Non-asbestos brake discs use high quality low abrasion aramid fibre material for a safer and healthier environment
- Free wheeling feature enables the operator to pay out cable fast
- Will not free wheel under load
- Dust and weather-tight housing using an ABS plastic cover to seal out dust and rain
- Handle grip is designed to allow maximum comfort during winding
- Handle length is easily adjustable

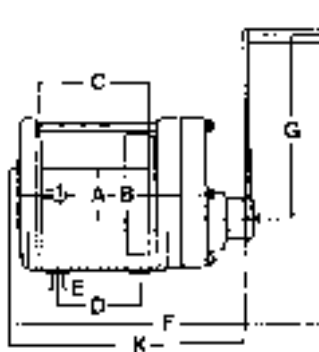

PROD. NO.	MOD. NO.	A	B	C	D	E	F	G	H	I	J	K
113261	IWF-100N	1-7/8"	4-1/32"	4-11/16"	3-1/4"	7/16"	15-15/16"	9-13/16"	5-51/64"	3-35/64"	6-19/64"	9-5/8"
113263	IWF-500N	2-3/4"	5-33/64"	5-29/32"	3-15/16"	19/32"	19-13/64"	13-3/4"	7-11/64"	5-1/8"	9-31/32"	12-15/16"
113264	IWF-1000N	3-1/2"	6-57/64"	6-7/64"	4-21/64"	45/64"	20-53/64"	13-3/4"	8-7/16"	6-45/64"	10-31/64"	14-9/16"

PROD. NO.	MOD. NO.	Rated Lifting Capacity (lb)	Drum Capacity	Cable Length Pulled Per Turn	Force Req. to Lift Capacity (lb)	Handle Length	Gear Ratio	Shipping Weight lb (kg) *
113261	IWF-100N	220	5/32" x 131'	6-1/2"	26	9-13/16"	1:1	31.9 (14.5)
113263	IWF-500N	882	1/4" x 98'	2-3/16"	25	13-3/4"	4.33:1	39.6 (18)
113264	IWF-1000N	1,653	5/16" x 98'	1"	22	13-3/4"	12.2:1	99 (45)

* Shipping weights are approximate

PT Series – Heavy Duty

- High quality 5,500 lb capacity
- High tensile steel frame and one piece "C" section forks with welded reinforcement for superior strength
- 3 position control lever automatically returns to neutral position
- Handle operates from rear and sides and returns to upright position when released
- Ergonomic handle grip for operator comfort and positive control
- Entry rollers in front of load rollers allow easy entry and exit from pallets
- Totally sealed hydraulic pump for reliable leak-free operation
- Built-in overload protection and top of stroke bypass valve prevents damage
- Slow lowering hand control valve for optimum control
- Large diameter polyurethane coated steel steer wheels and polyurethane load rollers for maximum manoeuvrability and smooth transport of heavy loads
- Steering column swivels 202°
- Fully adjustable push rods for fork height adjustment
- 27" x 48" forks are extra wide for maximum strength
- Grease fittings at all key points



PROD. NO.	MOD. NO.	Rated Lifting Capacity (lb)	Skid Quantity	W1	W2	L1	L2	H1	H2	A	B	Shipping Weight lb (kg) *
190918	PT-5500	5,500	6	27"	7"	48"	61-1/2"	7-1/4"	2-31/32"	7-7/8" x 2-1/2"	2-29/32" x 3-55/64"	213 (96)



Totally sealed H.D. hydraulic unit steel wheel wrapped in polyurethane



Three position control lever for operator convenience



Heavy duty single front wheel with entry, exit roller wheel



Fully adjustable push rods

SCISSOR LIFT HAND CART

SLC Series – Heavy Duty

- Hydraulic table designed for lifting and lowering
- Foot pedal for easy table lifting
- Wire control for convenient operation is superior to knob control
- Large table size
- Wheel stops for positioning cart
- Polyurethane casters for smooth travel
- Industrial quality



PROD. NO.	MOD. NO.	Rated Lifting Capacity (lb)	Minimum Table Height	Maximum Table Height	Handle Height	Table Dimensions	Wheel Diameter	Foot Pedal Cycles to Max. Height
190968	SLC-1100	1,100	11-1/2"	35-3/4"	38-7/8"	33-1/2 x 19-3/4"	5"	27

* Shipping weights are approximate

WARRANTY

WARRANTY POLICY

JET EQUIPMENT & TOOLS LTD. (JET),

makes every effort to ensure its products are manufactured to the highest standards and are guaranteed against defects in materials and workmanship when the product is used for the purpose for which it was designed.

This guarantee applies only to JET products purchased new from a JET authorized distributor.

JET product warranties are extended to the original retail purchaser only.

This warranty does not apply to any product showing signs of abuse, misuse, alteration, or having been improperly maintained or repaired.

This warranty does not cover damage attributable to normal wear and tear.

Any JET product that fails during normal use and is within the specified warranty period for that product will be repaired or replaced at JET'S discretion. Repairs and/or replacements are warranted as described for the specific product and only for the remainder of the original warranty period.

Repair or replacement is the exclusive remedy for defective product under this warranty.

Warranty is expressly in lieu of all other warranties, including the implied warranty of merchantability or any implied warranty of fitness for a particular application.

Any JET product for which there is a warranty claim should be returned PREPAID to an authorized JET distributor or service center. Authorized Warranty Depots are found at www.surewerx.com

ALL warranty claims must be accompanied by proof of purchase and an explanation of the defect or failure. It is the customer's responsibility to provide this information. JET shall not be held liable for any consequential or incidental damages for breach of any expressed or implied warranty on their products. No claims for damages of any type will be considered and all products are sold with this understanding.

Any costs incurred to obtain warranty consideration or services are the customer's responsibility including shipping and handling, travel, lost time, or lost production.

1 Year Limited Warranty

Chain Hoists	Hand Cable Pullers
Electric Hoists	Lever Chain Pullers
Drum Clamps	Grip Pullers
Plate Clamps	Manual Adjustable Trolleys
Beam Clamps	Blocks and Sheaves
Pallet Trucks	Mobile Lift Tables
Winches	

General information on JET chain hoists and pullers

Customs Lifts - Custom lift lengths are available, however, custom lift hoists and pullers are NOT returnable.

CAUTION: Be sure that supporting structures and load-attaching devices used in conjunction with hoists, provide an adequate safety factor to handle the rated load plus the weight of the equipment. If in doubt, consult a qualified structural engineer.

This equipment is not to be used for lifting, supporting, or transporting people, or lifting, supporting, or transporting loads over people.

IMPORTANT: Before installation and operation, see maintenance and operations manual for additional warnings, precautions and operating instructions.

SAFETY GUIDE

DO

BEFORE INITIAL OPERATION OF HOIST:

1. Read and comply with all instructions and warnings furnished.
2. Check lubricant.
3. Check operation of brake.
4. Check that chain is properly seated in sheaves and that chain is not twisted, kinked, or damaged.

BEFORE EACH SHIFT:

1. Inspect hooks for nicks, gouges, cracks, and signs of pulling apart or twisting.
2. Inspect hook latch for proper operation.
3. Check chain for kinks or twists.
4. Check operation of brake.
5. Replace warning label if missing or illegible.

BEFORE OPERATING:

1. Be certain all personnel are clear of the load to be lifted and moved.
2. Make sure load will clear stock piles, machinery, or other obstructions when hoisting and traveling the load.
3. Eliminate any twists or kinks in the load chain.

DO NOT

1. Lift more than rated load.
2. Operate lever hoist when it is restricted from forming a straight line with the direction of loading.
3. Operate with twisted, kinked, or damaged chain.
4. Operate if chain is not seated in sheaves or sprockets.
5. Wrap chain around load or use chain as a sling.
6. Operate unless load is properly applied to the saddle or bowl of the hook.
7. Operate if load is applied to the tip of the hook.
8. Operate with damaged or missing hook latches.
9. Lift people or lift loads over people.
10. Operate with side-pulling or side-loading of load to lever hoist.
11. Operate a damaged or malfunctioning lever hoist.
12. Operate with other than hand power.
13. Remove, deface, or obscure warning label or labels on lever hoist.
14. Leave load suspended when lever hoist is unattended unless specific precautions have been instituted and are in place.
16. Lengthen load chain or repair damaged load chain by welding.
17. Use chain as a ground for welding.
18. Hammer on lever.
19. Use extensions on lever.
20. Lift one load with more than one lever hoist, unless each lever hoist is rated to support the entire load in the event one or more lever hoists is disabled, shifting load to the other lever hoists.



INDUSTRIAL POWER EQUIPMENT

**SAFETY
AND
PRODUCTIVITY**

DESIGN

With features like heavy duty cages and noise reduction, our products are designed to keep you productive and safe

QUALITY

From piston rings to brass fittings to high grade rubber hoses, only the best materials are used in our products

STANDARDS

Our products are built to meet or exceed the toughest CSA standards so workers can trust they are safe and reliable

DID YOU KNOW?

JET provides comprehensive instructions on how best to use and maintain your equipment to ensure long life



TABLE OF CONTENTS

Generators	596
Generators.....	596-597
Pressure Washers	598
Pressure Washers.....	598-600
Pressure Washer Accessories.....	601-605
Pressure Washer Pumps.....	606
Water Pumps	607
Trash Pumps	608
Trash Pumps.....	608-609
Chemical Transfer Pumps	610
Hoses	611
Water/Trash Pump - Discharge Hoses.....	611
Water/Trash Pump - Suction Hose Kits.....	611
Submersible Pumps	612
Warranty Policy.....	613



JET PEAK PERFORMANCE ENGINES

WITH OVERHEAD VALVE DESIGN



OVERHEAD VALVE (OHV) ENGINES

Overhead Valve (OHV) engines are more efficient and burn cleaner than side-valve engines. Superior airflow and engine block design help the engine run cooler than other leading engines, ensuring maximum engine life.

Before each JET Premium Engine leaves the assembly line, it is tested under load and checked for power levels and governor response, to ensure consistent peak performance.

JET Premium Engines feature rugged construction for years of dependable performance.

PREMIUM OHV ENGINES
BUILT FOR MAXIMUM PERFORMANCE



Hardened Valve Guides
and die cast connecting rods for strength and optimum life



Automatic Compression Release
is easier to turn over, resulting in less wear on your starter and battery



Dual Crankshaft Bearings
provide less friction and longer life



Cast Iron Cylinder Liner
for longest life



Service Recoil
simplifies maintenance and repairs for less downtime!



Tripod Piston Ring
design for reduced oil consumption and maximum power



Overhead Valve Design
is more efficient and burns cleaner for peak performance



GENERATORS



NEW



3,500 Watt Electric Start Inverter

291109 / JIN3500E

- JET Inverter technology provides 3,500 watts of peak power
- Extremely quiet, lightweight and fuel-efficient power
- Operates a wide variety of appliances, making it perfect for portable use at home or while camping
- Can be combined with another JIN3500E with a parallel cord to double the power output
- Ideal for microwaves, coffee pots, televisions, computers, hair dryers and refrigerators
- 10 litre fuel tank runs the generator continuously for up to 15 hours @ 50% rated load
- 212 cc, 4-stroke engine runs on gasoline to provide dependable power
- Includes receptacles: 1 x 120V 20A Duplex, 1 x 120V 30A Twistlock and 12V DC 8.0A
- Auto idle down
- Includes wheels for easy mobility with a locking caster
- Compact size and weight make it easy to transport
- Parallel capability
- Digital display meter

3,100 Watt Generator

291101 / JGE3100

- Gasoline powered generator provides up to a max of 3,100 watts, 2,800 watts running, of electricity
- Powered by a 7 HP (212cc) JET engine with low oil alert
- Features 4 x 120V GFCI plugs, 1 x 120V Twist-Lock plug, and a 12V / 8amps DC receptacle ideal for charging car batteries
- (AVR) automatic voltage regulator
- Fuel gauge
- Circuit breakers
- Receptacles: 4 x 120V GFCI, 1 x 120V Twist-Lock, 12V DC

6,500 Watt Generator

291103 / JGE6500E

- Gasoline powered generator provides up to a max of 6,500 watts, 5,500 watts running of electricity
- Powered by a 13 HP (389cc) JET electric start engine with low oil alert
- Features 4 x 120V GFCI plugs, 1 x 120V Twist lock plug, 1 x 240V Twist-Lock plug, and a 12V / 8amps DC receptacle ideal for charging car batteries
- Automatic voltage regulator (AVR)
- Automatic idle down
- Includes: Handles, 8" wheel kit and battery
- Receptacles: 4 x 120V GFCI, 1 x 120V Twist-Lock, 1 x 240V Twist-Lock, 12V DC

PROD. NO.	291101	291103	291109
Generator	3,100 Watt	6,500 Watt	3,500
Engine	212 cc JET	389 cc JET	212 cc
Starter	Recoil	Electric	Electric
Shutdown	Low Oil	Low Oil	Low Oil
Regulator	Automatic Voltage Regulator (AVR)	Automatic Voltage Regulator (AVR)	
Maximum Watt Output	3,100	6,500	3,500
Running Watt Output	2,800	5,500	3,000
Noise Level @7m	70 dB	74 dB	
Fuel Tank Capacity	3.17 GAL (12 L)	6.6 GAL (25 L)	10 L
Run Time Per Tank	7 Hours @ Full Load	7 Hours @ Full Load	15 hours @ 50% rated load



9,000 Watt Generator

291105 / JGE9000E

- Gasoline powered generator provides up to a max of 9,000 watts, 7,100 watts running of electricity
- Powered by a 15 HP (420 cc) JET electric start engine with low oil alert
- Features 6 x 120V GFCI plugs, 1 x 120V Twist-Lock plug, 1 x 240V Twist-Lock plug, and a 12V / 8 amp DC receptacle ideal for charging car batteries
- Automatic voltage regulator (AVR)
- Fuel gauge
- Circuit breakers
- Automatic idle down
- Includes: Handles, 8" wheel kit, battery
- Receptacles:
 - 6 x 120V GFCI
 - 1 x 120V Twist-Lock
 - 1 x 240V Twist-Lock
 - 12V DC



POWERED by HONDA

6,800 Watt Generator

291107 / JGE6800GX

- Gasoline powered generator provides up to a max of 6,800 watts, 5,800 watts running, of electricity
- Powered by a Honda GX 390 (389 cc) electric start engine with low oil alert
- Features 2 x 120V Duplex plugs, 1 x 120V Twist-Lock plug, 1 x 240V Twist-Lock plug, and a 12V / 8amps DC receptacle ideal for charging car batteries
- Automatic voltage regulator (AVR)
- Digital multi-meter
- Fuel gauge
- Circuit breakers
- Automatic idle down
- Includes: Handles, 8" wheel kit and battery
- Receptacles:
 - 2 x 120V 20a duplex
 - 1 x 120V Twist-Lock
 - 1 x 240V Twist-Lock
 - 12V DC



PROD. NO.	291105	291107
Generator	9,000 Watt	6,800 Watt
Engine	420 cc JET	389 cc Honda GX390
Starter	Electric	Electric
Shutdown	Low Oil	Low Oil
Regulator	Automatic Voltage Regulator (AVR)	Automatic Voltage Regulator (AVR)
Maximum Watt Output	9,000	6,800
Running Watt Output	7,100	5,800
Noise Level @7m	74 dB	78 dB
Fuel Tank Capacity	6.6 GAL (25 l)	6.6 GAL (25 l)
Run Time per Tank	6.5 Hours @ Full Load	6.5 Hours @ Full Load



PRESSURE WASHERS



Axial Pump



Triplex Pump

3,100 PSI High Pressure Washer

291001 / JPW3100L

- Powered by a reliable 212 cc JET engine
- 3,100 PSI, 2.3 GPM
- Mounted on a rugged powder coated steel frame
- AR direct drive axial pump
- 2.3 gallons per minute cleans quickly and economically
- 25 feet of 1/4" high quality rubber high pressure hose
- Quick connect nozzles in 0°, 15°, 40°, and soap nozzle (**291410**)
- Convenient on-board spray tip storage
- 10" pneumatic tires reduce vibration and easily handle tough terrain

4,000 PSI High Pressure Washer

291005 / JPW4000L

- Powered by a reliable 420 cc JET engine
- 4,000 PSI, 4.0 GPM
- Mounted on a rugged powder coated steel frame
- Triplex plunger pump
- 4 gallons per minute cleans quickly and economically
- 50 feet of 3/8" rubber hose resists kinking
- Low pressure chemical injector
- Quick connect nozzles in 0°, 15°, 40°, and soap nozzle (**291409**)
- Convenient on-board spray tip storage
- Oversize pneumatic tires move easily over rugged terrain, help absorb vibration

PROD. NO.	291001	291005
Engine	JET	JET
HorsePower	212 cc	420cc
Pump	Axial	Triplex
Maximum Pressure	3,100 PSI	4,000 PSI
Maximum Flow	2.3 GPM	4.0 GPM
High Pressure Hose	25 ft	50 ft

Triplex Pump Features

Triplex series are designed for direct drive on gasoline engines ranging from 5-13 HP. Intended use for medium to heavy tasks; this triplex plunger pump features the latest in design and technology. Life tested over 500 hours at maximum performance of 4 GPM at 4,000 PSI. The triplex series features a compact and efficient intergrated unloader valve and fixed chemical injector.

POWERED by
HONDA™

2,700 PSI High Pressure Washer

291007 / JPW2700GC

- Powered by 160 cc Honda GC160 engine
- 2,700 PSI, 2.3 GPM
- Mounted on a rugged powder coated steel frame
- AR direct drive axial pump
- 2.3 gallons per minute cleans quickly and economically
- 25 feet of 1/4" high quality rubber high pressure hose
- Quick connect nozzles in 0°, 15°, 40°, and soap nozzle (**291410**)
- Convenient on-board spray tip storage
- 10" pneumatic tires reduce vibration and easily handle tough terrain



Axial Pump

3,000 PSI High Pressure Washer

291009 / JPW3000GX

- Powered by 196cc Honda GX200 engine
- 3,000 PSI, 2.3 GPM
- Mounted on a rugged powder coated steel frame
- AR direct drive axial pump
- 2.3 gallons per minute cleans quickly and economically
- 25 feet of 1/4" high quality rubber high pressure hose
- Quick connect nozzles in 0°, 15°, 40°, and soap nozzle (**291410**)
- Convenient on-board spray tip storage
- 10" pneumatic tires reduce vibration and easily handle tough terrain



Axial Pump

PROD. NO.	291007	291009
Engine	Honda GC160	Honda GX200
HorsePower	160 cc	196 cc
Pump	Axial	Axial
Maximum Pressure	2,700 PSI	3,000 PSI
Maximum Flow	2.3 GPM	2.3 GPM
High Pressure Hose	25 ft	25 ft

Axial Pump Features

Plungers: Hardened stainless steel

Valves: Stainless steel poppet, seat and cage, stainless steel spring

Seals: Buna-N dual seals

Bearings: Premium oversized ball and needle bearings

Crankshaft: Precision die-cast, with cooling fins for maximum heat dissipation.

The housing retains the crankshaft bearing, oil seal and rear wobble plate bearing support washer.



PRESSURE WASHERS

POWERED by
HONDA™



Triplex Pump

3,100 PSI High Pressure Washer

291008 / JPW3100GX

- Powered by 196 cc Honda GX200 engine
- 3,100 PSI, 3.0 GPM
- Mounted on a rugged powder coated steel frame
- Triplex plunger pump
- 3 gallons per minute cleans quickly and economically
- 25 feet of 1/4" high quality rubber high pressure hose
- Quick connect nozzles in 0°, 15°, 40°, and soap nozzle (**291410**)
- Convenient on-board spray tip storage
- 10" pneumatic tires reduce vibration and easily handle tough terrain



Triplex Pump

4,000 PSI High Pressure Washer

291011 / JPW4000GX

- Powered by a reliable 389 cc HONDA GX390 engine
- 4,000 PSI, 4.0 GPM
- Mounted on a rugged powder coated steel frame
- Triplex plunger pump
- 4 gallons per minute cleans quickly and economically
- 50 feet of 3/8" rubber hose resists kinking
- Low pressure chemical injector
- Quick connect nozzles in 0°, 15°, 40°, and soap nozzle (**291410**)
- Convenient on-board spray tip storage
- Oversize pneumatic tires move easily over rugged terrain and help absorb vibration

PROD. NO.	291008	291011
Engine	Honda GX200	Honda GX390
HorsePower	196 cc	389 cc
Pump	Triplex	Triplex
Maximum Pressure	3,100 PSI	4,000 PSI
Maximum Flow	3.0 GPM	4.0 GPM
High Pressure Hose	25 ft	50 ft

25' High Pressure Rubber Hose

291412 / PWRH14

- 4,000 PSI
- 1/4" rubber hose
- 25 foot
- Single wire braid wrapped cover
- 3/8" quick connect brass coupler, steel plug
- Maximum temperature: 212°F



50' High Pressure Rubber Hose

291413 / PWRH38

- 4,000 PSI
- 3/8" rubber hose
- 50 foot
- Single wire braid wrapped cover
- 3/8" quick connect brass coupler, steel plug
- Maximum temperature: 310°F



4,000 PSI Pressure Washer Gun and Wand Assembly

291405 / PWGW4

- 36" spray gun and wand
- Maximum pressure: 4,000 PSI
- Comes with quick disconnect coupler
- Insulated grip fights fatigue
- For use with premium and commercial grade pressure washers
- Standard replacement assembly for all JET branded units



3,400 PSI Pressure Washer Gun and Wand Assembly

291406 / PWGW3

- 36" spray gun and wand
- Maximum pressure: 3,400 PSI
- Front load 3/8" FNPT inlet
- Outlet 1/4" quick connect
- Comfort grip handle
- Nozzle holder lance
- Optional Accessories: Side handle (PBE-85202057)



1/4" MNPT Thermal Relief Valve

291415 / PWTV14

- Maximum Pressure: 200 PSI
- Maximum Temperature: 145°F
- Inlet: 1/4" MNPT
- The thermal relief valve keeps pressure cleaner pumps operating in a safe range to prevent overheating (caused by recirculating water). At water temperatures above 145° F, packing seals may fail. The pump then overheats. When the system is in bypass mode, the thermal relief valve opens to release hot water. Cold water can then enter the pump so it continues to operate at a safe temperature. Should the pump overheat, thermal relief valves must be replaced





PRESSURE WASHER ACCESSORIES

Pressure Washer Nozzle Kit Quick Connect Spray Tips # .030

291410 / PWNS30

- 1/4" quick connect spray nozzle
- 4 pack nozzle set # .030
- 0° (red), 15° (yellow), 40° (white) and soap nozzle (black)

Pressure Washer Nozzle Kit Quick Connect Spray Tips # .035

291411 / PWNS35

- 1/4" quick connect spray nozzle
- 4 pack nozzle set # .035
- 0° (red), 15° (yellow), 40° (white) and soap nozzle (black)

5,000 PSI Rotary Nozzle

291409 / PWRNWF

- This rotary nozzle cleans faster than a regular nozzle. It is great for stripping paint or cleaning concrete surfaces
- Includes a 5,000 PSI rated inline filter to reduce wear and keep the nozzle orifice clear
- Minimum Pressure: 2,000 PSI
- Maximum Pressure: 5,000 PSI
- Maximum Temperature: 212° F
- Minimum Flow: 3 GPM
- Maximum Flow: 8 GPM
- Astounding 4,000 RPM cleans deeper and faster
- Inlet: Stainless Steel water filter with 1/4" quick connect (attaches to the tip of the wand)
- Wear-resistant ceramic nozzle and rugged housing for longer life
- Patent spring loaded nozzle can be started in any position
- Weight: 1.10 lbs
- Can be used with all JET pressure washers

Long Range Soaper Nozzle

291408 / PWTWGC

- Apply detergent and soap from up to 20 feet away
- Rated to 4,000 PSI
- Brass and hard plastic construction
- Uses 1/4" quick connects
- Variable spray for straight stream or flat fan spray
- Can be used with all JET pressure washers

3,200 PSI Rotary Nozzle

291427 / PWRNSD

- This rotary nozzle cleans faster than a regular nozzle using a rotating roto spray
- Great for stripping paint or cleaning concrete surfaces
- Use with any pressure washer equipped with quick connect and a minimum of 2.0 GPM of water flow
- Can be used with all JET pressure washers

18' Telescoping Wand

291407 / PWTW18

- Clean up to 18 feet high without a ladder
- Easily reach soffits, fascia, siding and gutters from the ground
- Comfortable padded grip. Let's you work longer with less fatigue
- 3 adjustable sections with lever locks
- One 6-1/2 foot fiberglass section and two 6 foot aluminum sliding sections set up the length you need, then lock it down for even results
- Durable threaded gun
- Adaptors included for M22 and quick connect supply hoses
- Removes easily for storage and quick field adjustments
- Use your own quick connect spray tips
- Wand has a socket that accepts most quick connect spray tips
- Will also accept gutter cleaner extension (sold separately) - **291420**
- Maximum 4,000 PSI and 8 GPM; works best above 2,000 PSI
- Will not work with consumer-grade electric pressure washers
- Apply soap using your low pressure black tip and siphon tube
- Optional Accessories: **291420** gutter cleaner

16" Flat Surface Cleaner

291400 / WHAW16

- Powerful solution to flat surface cleaning
- Designed to operate with both hot and cold water pressure washers up to 180°F
- Hover action is ideal for cleaning aggregate, stamped concrete and other flat surfaces
- Easy to handle frame is designed for less operator fatigue
- Heavy duty polypropylene cover and durable nylon brush skirt
- For use with: 9 HP or larger gasoline engines
- 16" diameter cover
- 4,000 PSI rotary head
- Zero wall clearance
- Welded steel two arm rotary bar

12" Pressure Washer Water Broom

291421 / PWWB12

- High pressure concrete surface cleaners or water brooms are powerful, reliable and universal in pressure washing driveways, boat decks, flat surfaces and more
- Used to clean flat surfaces quickly, easily and evenly
- Easy to maneuver - uses 2 large caster wheels provide uniform results
- Maximum pressure: 4,000 PSI
- Maximum flow: 3.0 GPM
- Inlet: 1/4" plug
- Width: 12"
- Nozzles: 3





PRESSURE WASHER ACCESSORIES

Gutter Cleaner

291420 / PWTWGC

- Gutter cleaner for use with the 291407 (PWTW18) Telescoping Wand Assembly 18 ft
- Attaches to 1/4" quick connector on many pressure washer wands
- Also great for car/truck underbody and wheel well cleaning
- Fits many pressure washer brands - snaps into 1/4" quick connection wands
- Maximum pressure: 4,000 PSI
- Maximum flow: 4.0 GPM
- Will not work with consumer electric pressure washers

12" Flat Surface Cleaner

291426 / WHAW12

- Powerful solution to flat surface cleaning
- Designed to operate with both hot and cold water pressure washers up to 180°F
- Hover action is ideal for cleaning aggregate, stamped concrete and other flat surfaces
- Connects directly to a 1/4" quick connect coupler
- Heavy duty polypropylene cover and durable nylon brush skirt
- For use with: 9 HP or larger gasoline engines
- 12" diameter cover
- 4,000 PSI rotary head

1/2 Litre Pump Oil

291424 / PWPOIL

- Ideal for high pressure pumps
- Non-detergent and non-foaming
- Specially formulated and rated for superior rust protection and oxidation protection
- Not for use in engine

Low Pressure Injector Kit

291418 / PWLPCI

- Increases your pressure washer's effectiveness
- Unique siphoning design draws chemicals or soap to aid in your cleaning flexibility
- Be sure to use the 291414 (PWQCC) connector when using this injector kit
- Maximum pressure: 4,000 PSI
- Maximum flow: 2 to 5.0 GPM
- Inlet 3/8" quick connect, Outlet 3/8" plug
- Maximum temperature: 195°F

Chemical / Soap Injector Hose Assembly

291419 / PWCIIA

- Includes 4 ft hose and suction filter



2.5" Pressure Washer Gauge Kit

291417 / PWGAKT

- Gauge kit with quick connect
- Installs on the outlet of the pump to measure system performance
- Size: 2.5"
- Inlet: 3/8" quick connect plug
- Outlet: 3/8" quick connect plug
- Maximum pressure: 5,000 PSI
- Pressure gauges enable the user to see what pressure levels their system is developing. Accurate gauges can warn of internal pump damage, cavitation, pressure spikes, and other problems
- Glycerin filled
- When selecting your pressure gauge, always allow at least 10% above the maximum capacity of your unit. For example: if your machine is rated 4,000 PSI, you must purchase a gauge that has a maximum range of 5,000 PSI



Quick Connect Fittings Kit

291422 / PWCKIT

- Quick Connects allow equipment to be installed or removed quickly and safely without drips and leaks.
- Comes with 1/4 and 3/8 coupler and plug
- Maximum Pressure: 4,000 PSI
- Temperature: up to 160° F
- Connects hose to hose, hose to gun or hose to pump



O-Ring and Filter Kit

291423 / PWORKT

- Replacement O-ring and filter for hose and wand connectors



Three Position Pivot Coupler

291416 / PWPVCP

- Adjustable high pressure coupler for end of spray wand
- Maximum Pressure: 4,000 PSI
- 1/4" quick connect
- Pivots 90°





Axial Pump

This plunger pump will pump up to 2.5 GPM at 3,000 PSI. It spins at 3,400 RPM in a direct drive system coupled with a gasoline engine. The matching flange provides convenient connection to most 3/4" shaft 1.1 - 5.5 HP engines. The hollow shafted pump includes a built-in pressure control valve, and chemical injection system.



Triplex Pump

Triplex series are designed for direct drive on gasoline engines ranging from 5-13 HP. Intended use for medium to heavy tasks; this triplex plunger pump features the latest in design and technology. Life tested over 500 hours at maximum performance of 4 GPM at 4,000 PSI. The triplex series features a compact and efficient intergrated unloader valve and fixed chemical injector.

PRESSURE WASHER PUMPS

3,000 PSI Pressure Washer Axial Pump

291401 / JAP700

- Maximum flow: 2.5 GPM
- Maximum pressure: 3,000 PSI
- Engine speed: 3,400 RPM
- 4 bolt flange fits on horizontal direct drive pressure washer engines 5 to 7 HP
- Die cast aluminum body with brass head
- Quick connect fittings connect to quick connect high pressure hose
- Screw-type fittings (M22) connects to screw-type high pressure hose
- Garden hose fitting with screen washer
- Chemical injector with soap hose and filter
- Adjustable pressure unloader
- Thermal relief valve

3,100 PSI Pressure Washer Triplex Pump

291403 / JAP710

- Maximum flow: 3.0 GPM
- Maximum pressure: 3,100 PSI
- Engine speed: 3,400 RPM
- 4 bolt flange fits on horizontal direct drive pressure washer engines 5 to 7 HP
- Die cast aluminum body with brass head
- Quick connect fittings connect to quick connect high pressure hose
- Screw-type fittings (M22) connects to screw-type high pressure hose
- Garden hose fitting with screen washer
- Chemical injector with soap hose & filter
- Adjustable pressure unloader
- Thermal relief valve

4,000 PSI Pressure Washer Axial Pump

291402 / JAP715

- Maximum Flow: 4.0 GPM
- Maximum Pressure: 4,000 PSI
- Engine Speed: 3,400 RPM
- 4 bolt flange fits on horizontal direct drive pressure washers 8 to 15 HP
- Die cast aluminum body with brass head
- Quick connect fittings connect to quick connect high pressure hose
- Screw-type fitting (M22) connects to screw-type high pressure hose
- Garden hose fitting with screen washer
- Chemical injector with soap hose and filter
- Adjustable pressure unloader
- Thermal relief valve

WATER PUMPS



- Commercial grade aluminum housing
- Recoil start and low oil shutdown
- Centrifugal aluminum pump
- Cast iron impeller and volutes
- Commercial duty mechanical ceramic seal
- Heavy duty commercial frame

2" Water Pump 291037 / JWP20L

3" Water Pump 291038 / JWP30L

4" Water Pump 291039 / JWP40L

PROD. NO.	291037	291038	291039
Inlet or Discharge	2" NPT	3" NPT	4" NPT
Engine	JET	JET	JET
HorsePower	212 cc	212 cc	420 cc
Maximum Flow	158 GPM	264 GPM	422 GPM
Total Lift	82 ft	85 ft	98 ft
Suction Lift	26 ft	26 ft	26 ft
Fuel Tank Capacity	.95 GAL (3.6 l)	.95 GAL (3.6 l)	1.7 GAL (6.5 l)
Impeller or Volute	Iron	Iron	Iron



- Commercial grade aluminum housing
- Recoil start and low oil shutdown
- Centrifugal aluminum pump
- Cast iron impeller and volutes
- Commercial duty mechanical ceramic seal
- Heavy duty commercial frame

2" Water Pump 291031 / JWP20GX

3" Water Pump 291033 / JWP30GX

4" Water Pump 291035 / JWP40GX

PROD. NO.	291031	291033	291035
Inlet or Discharge	2" NPT	3" NPT	4" NPT
Engine	Honda	Honda	Honda
HorsePower	GX200	GX200	GX390
Maximum Flow	158 GPM	264 GPM	422 GPM
Total Lift	82 ft	85 ft	98 ft
Suction Lift	26 ft	26 ft	26 ft
Fuel Tank Capacity	.82 GAL (3.1L)	.82 GAL (3.1L)	1.8 GAL (6.1L)
Impeller or Volute	Iron	Iron	Iron



291038



291039



291033



291035



291066



291068



291056



291060

TRASH PUMPS



- Commercial grade aluminum housing
- Cast iron impeller and volutes
- Commercial duty mechanical ceramic seal
- Low oil shut off
- Heavy duty commercial frame

2" Trash Pump

291066 / JTWP20L

3" Trash Pump

291067 / JTWP30L

3" Trash Pump - High Output

291068 / JTWP30LH

4" Trash Pump

291069 / JTWP40L

PROD. NO.	291066	291067	291068	291069
Engine	JET	JET	JET	JET
HorsePower	212 cc	212 cc	420 cc	420 cc
Maximum Flow	158 GPM	264 GPM	370 GPM	580 GPM
Total Lift	85 ft	85 ft	98 ft	95 ft
Suction Lift	26 ft	26 ft	26 ft	26 ft
Solids up to	5/8"	1"	1"	1"
Fuel Tank Capacity	.95 GAL (3.6 l)	.95 GAL (3.6 l)	1.7 GAL (6.4 l)	1.7 GAL (6.4 l)
Intake and Outlet Connection	2"	3"	3"	4"

POWERED by HONDA™

- Commercial grade aluminum housing
- Cast iron impeller and volutes
- Commercial duty mechanical ceramic seal
- Low oil shut off
- Heavy duty commercial frame

2" Trash Pump

291056 / JTWP20GX

2" Trash Pump - High Output

291060 / JTWP20GXH

3" Trash Pump

291058 / JTWP30GX

PROD. NO.	291056	291058	291060
Engine	Honda GX200	Honda GX200	Honda GX200
HorsePower	196 cc	196 cc	196 cc
Maximum Flow	158 GPM	264 GPM	180 GPM
Total Lift	85 ft	85 ft	88 ft
Suction Lift	26 ft	26 ft	26 ft
Solids up to	5/8"	1"	13/16"
Fuel Tank Capacity	.82 (3.1 l)	.82 (3.1 l)	.82 (3.1 l)
Intake and Outlet Connection	2"	3"	2"

TRASH PUMPS

POWERED by
HONDA™

- Commercial grade aluminum housing
- Cast iron impeller and volutes
- Commercial duty mechanical ceramic seal
- Low oil shut off
- Heavy duty commercial frame

3" Trash Pump 291061 / JTWP30GXH

4" Trash Pump 291062 / JTWP40GXH

PROD. NO.	291061	291062
Engine	Honda GX390	Honda GX390
HorsePower	389 cc	389 cc
Maximum Flow	370 GPM	580 GPM
Total Lift	98 ft	95 ft
Suction Lift	26 ft	26 ft
Solids up to	1"	1"
Fuel Tank Capacity	1.8 GAL (6.8 l)	1.8 GAL (6.8 l)
Intake and Outlet Connection	3"	4"





CHEMICAL TRANSFER PUMPS



- Fiberglass reinforced poly pump
- Fiberglass reinforced poly impeller
- Commercial duty mechanical ceramic seal
- Low oil shut off
- Heavy duty commercial frame

2" Chemical Transfer Pump

291085 / JCWP20L

3" Chemical Transfer Pump

291087 / JCWP30L

PROD. NO.	291085	291087
Engine	JET	JET
HorsePower	212 cc	212 cc
Maximum Flow	154 GPM	265 GPM
Total Lift	115 ft	92 ft
Suction Lift	26 ft	26 ft
Fuel Tank Capacity	.95 GAL (3.6 l)	.95 GAL (3.6 l)
Intake and Outlet Connection	2"	3"



- Fiberglass reinforced poly pump
- Fiberglass reinforced poly impeller
- Commercial duty mechanical ceramic seal
- Low oil shut off
- Heavy duty commercial frame

2" Chemical Transfer Pump

291080 / JCWP20GX

3" Chemical Transfer Pump

291083 / JCWP30GX

PROD. NO.	291080	291083
Engine	Honda GX200	Honda GX200
HorsePower	196 cc	196 cc
Maximum Flow	154 GPM	265 GPM
Total Lift	115 ft	92 ft
Suction Lift	26 ft	26 ft
Fuel Tank Capacity	.82 (3.1 l)	.82 (3.1 l)
Intake and Outlet Connection	2"	3"

WATER/TRASH PUMP – DISCHARGE HOSES

- Discharge hoses come with a Camlock system
- Rated for a working temperature of 150°F
- Camlock hoses are easier to attach and detach from the pump
- Hoses lay flat for easier storage
- For non chemical use



Water Pump Discharge Hose 2" x 50'	291475 / WPD250
Water Pump Discharge Hose 3" x 50'	291476 / WPD350
Water Pump Discharge Hose 4" x 50'	291477 / WPD450

PROD. NO.	291475	291476	291477
Size (inches)	2	3	4
Length (feet)	50	50	50
Pressure (PSI)	80	65	55



WATER/TRASH PUMP – SUCTION HOSE KITS

- Suction hose help draw water away from flooded areas
- Discharge hoses come with a Camlock system and a strainer
- Camlock hoses are easier to attach and detach from the pump

Water Pump Suction Hose Kit 2" x 25'	291478 / SHK225
Water Pump Suction Hose Kit 3" x 25'	291479 / SHK325
Water Pump Suction Hose Kit 4" x 25'	291480 / SHK425

PROD. NO.	291478	291479	291480
Size (inches)	2	3	4
Length (feet)	25	25	25
Camlock	Aluminum	Aluminum	Aluminum
Strainer	Steel	Steel	Nylon



291478



SUBMERSIBLE PUMPS - HEAVY DUTY

- 304 stainless steel motor housing – superior abrasion resistance will not wear out like aluminum motor housings when pumping sandy water
- Three seal motor protection - motor is protected by double mechanical seals. Lower seal made of silicon carbide/silicon carbide and upper seal is made of carbon/ceramic. An additional lip seal has been installed above the impeller, to help prevent abrasives such as dirt, silt or sand, from entering into the seal chamber
- More motor protection – winding protection and (NEMA) Class F motor insulation allows motor temperature to raise to 230°F, superior to pumps with Class A and B insulation. Automatic switch turns pump motor off if temperature and/or amp draw raises too high. When the motor cools the switch will automatically reset and the pump will turn back on
- Tough pump construction – hardened cast iron stands up to rough handling and pumping sandy water unlike pumps with soft resin impellers or plastic exterior components

1/2 HP Submersible Pump

290771 / R400-115

- Ideal for dewatering constructions sites, mines, circulating fountain water, or for all around use in industrial plants and utilities
- Top discharge – allows for superior cooling of motor and provides a slim line design
- Longer power cord – standard 33' power cord

1 HP Submersible Pump

290774 / R750-115

- Ideal for dewatering constructions sites, mines, circulating fountain water, or for all around use in industrial plants and utilities
- Top discharge – allows for superior cooling of motor and provides a slim line design
- Longer power cord – standard 50' power cord

1/2 HP Submersible Trash Pump

290784 / SV400-115

- Equipped with vortex impellers, undoubtedly the best non-clog impellers ever invented for the handling of mud, raw sewage, viscous liquids, rags, wood chips and other solids. They pass solid up to 90% of pump outlet diameter
- Longer power cord – standard 33' power cord

Accessories:

Pump Float Switch 0.5 HP (290791) & 1 HP (290792)

PROD. NO.	290771	290774	290784
Motor Rating (HP)	0.5	1	0.5
Max. Flow (GPM)	50	89	59
Max. Head (feet)	36	49.5	22
Pump Type	Top discharge, dewatering	Top discharge, dewatering	Non-clog vortex
Discharge Size	2" NPT-M	2" NPT-M	2" NPT-M
Max. Submerged Depth (feet)	65	65	65
Motor Casing	304SS	304SS	304SS
Pump Volute	Cast Iron	Cast Iron	Cast Iron
Impeller	Cast Iron	Cast Iron	Vortex Cast Iron
Lip Seals and O-Rings	Buna-N	Buna-N	Buna-N
Rotor Shaft	304SS	304SS	304SS
External Hardware	304SS	304SS	304SS
Qty. Oil in Seal Chamber (US oz)	1.35	3.7	5.1
Motor RPM	3,450	3,450	3,450
Motor Insulation	Class F	Class F	Class F
Motor Service Factor	1.1	1.1	1.1
Voltage	115v, 1ph-60hz	115v, 1ph-60hz	115/230v, 1ph-60hz
Current	F.L.A. 6	F.L.A. 6	F.L.A. 6
Motor Protection	Thermal Breaker	Thermal and Amp Overload	Thermal Breaker
Power Cord	Gage; Length A.W.G. 16/3; 33', Stow	Gage; Length A.W.G. 14/3; 50', Stow	Gage; Length A.W.G. 16/3; 33', Stow
Max. Liquid Temperature	104° F	104° F	104° F

WARRANTY

WARRANTY POLICY

JET EQUIPMENT & TOOLS LTD. (JET) makes every effort to ensure its products are manufactured to the highest standards and are guaranteed against defects in materials and workmanship when the product is used for the purpose for which it was designed.

This guarantee applies only to JET products purchased new from a JET authorized distributor.

JET product warranties are extended to the original retail purchaser only.

This warranty does not apply to any product showing signs of abuse, misuse, alteration, or having been improperly maintained or repaired.

This warranty does not cover damage attributable to normal wear and tear.

Any JET product that fails during normal use and is within the specified warranty period for that product will be repaired or replaced at JET's discretion. Repairs and/or replacements are warranted as described for the specific product and only for the remainder of the original warranty period.

Repair or replacement is the exclusive remedy for defective product under this warranty.

Warranty is expressly in lieu of all other warranties, including the implied warranty of merchantability or any implied warranty of fitness for a particular application.

In many cases repairs may be accomplished by simply replacing a component, please contact JET regarding warranty procedures on Pressure Washers and Water Pumps, Western Canada 1-800-472-7685, Eastern Canada 1-800-387-3879. If it is deemed necessary that the product must be sent in for repair, it must be returned PREPAID to an authorized JET distributor or service centre. Authorized Warranty Depots may found at www.surewerx.com.

ALL warranty claims must be accompanied by proof of purchase and an explanation of the defect or failure. It is the customer's responsibility to provide this information.

JET shall not be held liable for any consequential or incidental damages for breach of any expressed or implied warranty on their products. No claims for damages of any type will be considered and all products are sold with this understanding.

Any costs incurred to obtain warranty consideration or services are the Customer's responsibility including shipping and handling, travel, lost time, or lost production.

PRESSURE WASHERS, WATER PUMPS AND GENERATORS

(i) One year if purchased by a retail consumer for regular domestic use; or (ii) 90 days if purchased for professional, commercial, industrial or rental use, in each instance from the date of original purchase.

All Triplex pumps carry a three year warranty against manufacturer's defects. Axial pumps carry a one year warranty. Note: this warranty only applies to defective manufacturer's workmanship as determined by the applicable manufacturer. This warranty does not apply where neglect, abuse, or "normal wear and tear" is involved. Items such as seal and valve kits are considered normal wear items. When commercially used, the warranty period is 90 days.

Honda Engine warranty is per manufacturer's warranty policy as per the engine owner operator's manual.

All accessories and components, are warrantable for 90 days against manufacturer's defects. Flat surface cleaner heads are warrantable for six months. Rotary nozzles are warrantable for repair only for 30 days from purchase date.

The warranty on pressure washer or water pumps do not cover repair damage due to freezing, chemical deterioration, rust, corrosion, scale build up, or failure to maintain adequate water supply.

SUBMERSIBLE PUMPS

One year limited warranty. Not included in this warranty are components and accessories which are considered consumable items or are subject to normal wear and tear.

CONTENTS

Bottle Jacks		616
Manually Operated - Heavy Duty	616	Hydraulic Bottle Jacks
Industrial Bottle Jacks		JTJ Series - Super Heavy Duty.....
JHJ Series - Super Heavy Duty.....	617	Mechanical Screw Jacks.....
Air/Hydraulic Bottle Jacks - Heavy Duty	618	
Service Jacks		621
Floor/Garage Jacks - Hydraulic.....	621-623	
Truck Axle Air/Hydraulic Jacks		624
Truck Axle Air/Hydraulic Jacks	624-627	
Single Stage Air/Hydraulic Service Jacks	628	
Air Lift Jacks.....	629-630	
Specialty Truck Equipment		631
Clutch Jack.....	631	Specialty Truck Equipment.....
Clutch Jack Accessories.....	631	
Stands		633
Stands.....	633-636	
Transmission Jacks		637
Transmission Jacks.....	637-639	
Engine Stands		640
Cranes - Hydraulic		641
Cranes - Hydraulic.....	641-642	
Shop Presses		643
Shop Presses.....	644-647	Shop Press Accessories / Replacement
		Parts
		645, 647
Collision Repair		648
Collision Repair.....	648-649	Foot Pumps.....
Hand Pumps.....	650	Rams.....
		651
Industrial Pumps & Rams		653
Single Acting Cylinders		Hand Pump Selection Chart.....
Capacity 5-95 Ton	654-655	Rubber Hydraulic Hoses
Low Height Single Acting Cylinders		Quick Couplers.....
Capacity 5-50 Ton	656-657	Hydraulic Valves
Single Acting Cylinders Hollow Centre		Pressure Gauges
Capacity 20-30 Ton.....	658-659	Gauge Adapters
Air/Hydraulic Foot Pumps.....	660	Warranty Policy.....
Single Acting Hand Pumps.....	661	



LIFTING & HYDRAULIC EQUIPMENT

**SAFETY
AND
PRODUCTIVITY**

DESIGN

With features like controlled descent to more stable and maneuverable wheels, our products are designed with your safety as job #1.

QUALITY

Whether it's the finest hardened steels, tough powder coating, or precision cup seals – the details make the difference.

STANDARDS

Our products are designed to meet or exceed ANSI-PASE standards – safety and performance that's industry-leading



DID YOU KNOW?

Strongarm is the leading brand of high quality lifting and hydraulic equipment in Canada



MANUALLY OPERATED - HEAVY DUTY

Bottle jacks can be used in vertical and horizontal positions



- Available in 2 – 50 ton capacities
- 12 and 20 ton models available in standard and low profile versions
- Can be used in vertical and horizontal positions (valve side down)
- Factory pre-tested to 150% of rated capacity
- Heat treated piston for maximum strength
- Heavy duty steel saddle for secure lifts
- Centred pump and ram for balance and easy positioning
- Convenient carrying handle on 12 – 50 ton models
- Model 352A is equipped with a second large diameter plunger for faster contact with load



030115

Equipped with a second large diameter plunger for faster contact to the load

PROD. NO.	MOD. NO.	Style	Cap. (Tons)	Low Height	High Height	Lift	Screw Ext.	Shipping Weight
030102	302A	Standard	2	6-1/4"	12-1/2"	3-3/4"	2-1/2"	6 lb (3 kg)
030103	304A	Standard	4	6-3/4"	12-1/4"	3-1/4"	2-1/4"	8 lb (4 kg)
030104	306A	Standard	6	8"	16"	5-1/4"	2-3/4"	11 lb (5 kg)
030105	308A	Standard	8	7-3/4"	15-3/4"	5-1/4"	2-3/4"	13 lb (6 kg)
030106	312A	Standard	12	8-1/2"	17"	5-3/4"	2-3/4"	17 lb (8 kg)
030107	314A	Low Profile	12	7"	13"	4"	2"	15 lb (7 kg)
030110	320A	Standard	20	9-1/2"	18-1/4"	6-1/4"	2-1/2"	27 lb (12 kg)
030111	322A	Low Profile	20	7-3/4"	14-3/4"	4-1/2"	2-1/2"	23 lb (10 kg)
030112	330A	Standard	30	11-1/4"	18-3/4"	7-1/2"	-	44 lb (20 kg)
030114	350A	Standard	50	11-3/4"	19-3/4"	8"	-	74 lb (33 kg)
030115	352A	Double Plunger	50	11-3/4"	19-3/4"	8"	-	94 lb (42 kg)

JET INDUSTRIAL BOTTLE JACKS

JHJ Series - Super Heavy Duty

- JET industrial hydraulic bottle jacks have earned a reputation for super heavy duty performance, reliability and dependability for over 40 years
- Electrically welded base and cylinder assures strength and eliminates leaks
- Not affected by temperature extremes
- All models work in upright, angle or horizontal positions
- Unique valving allows handle to remain in upright position when used horizontally for improved operation
- Cleated steel lift saddle for safest operator conditions
- Equipped with convenient extension screw for low pick up height adjustment
- Available in Standard and Low Profile (LP) models
- Fully serviceable; common release valve assemblies and other interchangeable parts allow quick repairs
- Rigidly adheres to JIS and ANSI standards
- Tested to over 150% of rated capacities
- Made in Japan



PROD. NO.	MOD. NO.	Rated Capacity (Tons)	Closed Height	Piston Travel	Head Screw Height	Maximum Height	Base Size	Handle Type (pieces)	Shipping Weight
140101	JHJ-2	2	7-1/8"	4-1/2"	2"	13-5/8"	4-5/16" x 2-9/16"	2	5.5 lb (2.5 kg)
140102	JHJ-3	3	7-1/2"	4-1/2"	2-3/8"	14-3/8"	4-1/2" x 2-13/16"	2	6.8 lb (3 kg)
140103	JHJ-5	5	7-7/8"	4-3/4"	2-3/4"	15-3/8"	5-3/16" x 2-15/16"	3	8.8 lb (4 kg)
140104	JHJ-8	8	7-7/8"	4-3/4"	2-3/4"	15-3/8"	6" x 3-1/2"	3	12.2 lb (5.6 kg)
140105	JHJ-12-1/2	12-1/2	9-1/2"	5-7/8"	3-1/8"	18-1/2"	6-1/2" x 4-3/16"	3	17.7 lb (8 kg)
140106	JHJ-12-1/2LP	12-1/2	6-3/4"	3-3/4"	3"	13-1/2"	6-1/2" x 4-3/16"	1	12.8 lb (5.8 kg)
140107	JHJ-17-1/2	17-1/2	10-7/16"	6-1/2"	3-1/8"	20-1/16"	7-1/8" x 4-5/8"	3	24 lb (10.9 kg)
140108	JHJ-17-1/2LP	17-1/2	6-3/4"	3-1/2"	2-3/4"	13"	7-1/8" x 4-5/8"	1	16.4 lb (7.5 kg)
140109	JHJ-22-1/2	22-1/2	10-5/8"	6-1/4"	-	16-7/8"	7-3/16" x 5-1/16"	3	29.5 lb (13.4 kg)
140110	JHJ-22-1/2LP	22-1/2	7-1/8"	3-3/8"	1-9/16"	12-1/16"	7-3/16" x 5-1/16"	1	19.7 lb (9 kg)
140111	JHJ-35	35	11"	6-1/4"	-	17-1/4"	7-9/16" x 5-9/16"	1	41 lb (18.5 kg)
140112	JHJ-60	60	12"	6-3/4"	-	18-3/4"	9-5/16" x 7-3/8"	1	82 lb (36.9 kg)



Vertical



Angle



Horizontal

Bottle Jacks can be used in vertical, angled and horizontal positions.

STRONGARM

Bottle jacks can be used in vertical and horizontal positions



030152



030442



030158

BOTTLE JACKS

AIR/HYDRAULIC BOTTLE JACKS - HEAVY DUTY

- Designed for use with compressed air systems at 90 PSI - quicker and faster than manual jacks!
- Factory pre-tested to 150% of rated capacity
- Heat treated piston for maximum strength
- Heavy duty steel saddle for secure lifts
- Convenient carrying handle
- Bypass mechanism prevents internal damage from over pumping

20 Ton Air/Hydraulic Bottle Jack - Super Heavy Duty

030158 / 385SHD

- Built tough for the rigors of the heavy duty trucking, agricultural and fleet business
- Operating pressure 110-120 PSI
- Dual return springs for faster ram retraction
- Safeties bypass system
- Reinforced base for added stability
- Precision machining reduces O ring damage
- Superior quality O rings for longer life and greater seal
- Premium components provide for a 4 to 1 greater life expectancy
- Manual function allows for normal operation anywhere, even without an air supply

PROD. NO.	MOD. NO.	Style	Cap. (Tons)	Low Height	High Height	Lift	Screw Ext.	Shipping Weight	Reach
030152	370C	Air/Hydraulic	12	10-1/4"	19-1/2"	7"	2-1/2"	30 lb (14 kg)	-
030157	380C	Air/Hydraulic	20	10-1/2"	20"	6-1/4"	2-1/2"	38 lb (17 kg)	-
030442	735	Air/Hydraulic	35	11"	16-3/4"	21-1/4"	5-3/4"	101 lb (45 kg)	55"
NEW 030158	385SHD	Air/Hydraulic	20	10.3"	20"	6.3"	3.3"	36 lb (16.2 kg)	-

HYDRAULIC BOTTLE JACKS

JTJ Series - Super Heavy Duty

- For use where exceptionally low pick up height is required
- Extra wide base for maximum stability
- Electrically welded base and cylinder assures strength and eliminates leaks
- 200° handle socket for operation from any direction
- Load can be applied to toe or head
- Capacity rated at toe and increases if load applied to head
- Complete with overload protection
- Not affected by temperature extremes
- Rigidly adheres to JIS and ANSI standards
- Tested to over 150% of rated capacities
- Made in Japan



PROD. NO.	MOD. NO.	Rated Capacity (Toe)	Rated Capacity (Head)	Minimum Height (Toe)	Maximum Height (Toe)	Minimum Height (Head)	Maximum Height (Head)	Base Size (L x W)	Shipping Weight
030192	SATJ-5SV	5 ton	6 ton	1"	5-5/8"	11-1/2"	16-1/8"	10-5/8" x 7-1/8"	51.7 lb (23.5 kg)
030195	SAJJ-10SV	10 ton	14 ton	1-1/4"	6-3/4"	13"	18-1/2"	11-1/4" x 9-1/2"	85 lb (38.6 kg)



MECHANICAL SCREW JACKS



SJ Series - Heavy Duty

- Professional contractor quality mechanical screw jack for all-purpose lifts and supports
- Holds loads indefinitely – will not creep
- Heavy-duty bell shaped cast base adds stability
- Head pivots to provide maximum contact
- Corrugated steel swivel head turns easily under load
- Acme type thread
- Easy to carry and position with built-in handle
- Turning bar (handles) sold separately
- Compliance: ANSI / ASME B30.1 standards
- Ideal for construction, structural moving, supporting machinery, automotive, trucks, industrial, agriculture and general maintenance

PROD. NO.	MOD. NO.	Rated Capacity (Tons)	Bar Hole Size	Minimum Height	Maximum Height	Handle	Shipping Weight
030173	SASJ-05	5	9/16"	9.45"	13.39"	030174	8.8 lb (4 kg)
030175	SASJ-10	10	11/16"	11.5"	17.83"	030176	15.4 lb (7 kg)
030178	SASJ-15	15	13/16"	13.86"	21.38"	030179	24.2 lb (11 kg)
030182	SASJ-20	20	1"	15.83"	24.88"	030183	31.9 lb (14.5 kg)
030186	SASJ-25	25	1"	16.61"	26.34"	030183	37.4 lb (17 kg)

Handles for SJ Series Jacks

PROD. NO.	MOD. NO.	Size	Fits Product Number	Shipping Weight
030174	SASJH-05	1/2" x 18"	030173	1.1 lb (0.5 kg)
030176	SASJH-10	5/8" x 24"	030175	2.2 lb (1 kg)
030179	SASJH-15	3/4" x 36"	030178	5.5 lb (2.5 kg)
030183	SASJH-20/25	1" x 42"	030182 / 030186	8.8 lb (4 kg)

HYDRAULIC SERVICE JACKS

JTJ Series - Super Heavy Duty

- All models designed for the professional user
- All models equipped with safety valve to prevent overloading
- Rear mounted swivel casters for easy maneuverability
- Heavy duty pump, ram and cylinders are precision machined and inspected to ensure long service life and superior performance

NOTE: Hydraulic Jacks are intended for lifting but not sustaining a partial vehicular load. Immediately after lifting, support the load with appropriate means such as high quality STRONGARM jack stands.

2-1/2 TON - Service Jack

030415 / 952B

- Model 952B has been the standard of the Canadian industry for over 20 years
- Heavy duty casters and saddle
- Two piece 40" handle
- A great floor jack for everyday use

Low Height	High Height	Length	Front Width	Rear Width	Shipping Weight
5"	19-1/4"	27"	10-3/4"	13"	93 lb (42 kg)



030415

2 TON - Low Rider Service Jack - Heavy Duty

030414 / 962L

- Super low pickup height of 2-3/4"
- Ideal for today's import cars and popular "Tuner" cars
- Equipped with a double pump design to increase speed without compromising overall performance of the jack
- Comes with padded handle and rubber saddle protector
- Safety valve prevents overload
- Universal joint technology for precision control of release valve
- Tough powder coated frame for longer shop life

Cap. (Tons)	Low Height	High Height	Length	Front Width	Rear Width	Shipping Weight
2	2-3/4"	20"	27"	11-3/4"	15"	75 lb (34 kg)



NEW

2 TON - Aluminum Racing Jack

030412 / 962AL

- Lightweight, only 43 lb (19.5 kg) and a 2 Ton Capacity makes this a very versatile jack for numerous applications from towing and service vehicle applications, general garage service to racers of all types
- Double pump design gets saddle to load quickly
- Padded 2 piece handle and saddle protect vehicle from damage
- Two side handles for easier portability
- Large front wheels for added stability

Cap. (Tons)	Low Height	High Height	Length	Front Width	Rear Width	Shipping Weight
2	3.5"	18.5"	25.75"	11.75"	11.75"	46 lb (21 kg)



NEW

STRONGARM



030406



030407

FLOOR/GARAGE JACKS - HYDRAULIC

3-1/2 TON - Service Jack - Heavy Duty

030406 / 965GTO

- The standard for tire and service shops in Canada
- Extra wide front casters for superior stability
- Two piece 50-1/4" padded handle and a rubber saddle
- Flanged side plates for increased strength and stability
- Universal joint technology for precision control of release valve
- Tough powder coated frame for longer shop life

Low Height	High Height	Length	Front Width	Rear Width	Shipping Weight
4"	19-1/2"	29"	11-1/4"	15"	119 lb (54 kg)

3-1/2 TON - Double Pumper Service Jack - Heavy Duty

030407 / 966HO

- Same great quality features as Model 965GTO
- Equipped with a double pump design to increase speed without compromising overall performance of the jack
- Second volume pump assists in getting the saddle to load much quicker than most other single pump designs on the market today

Low Height	High Height	Length	Front Width	Rear Width	Shipping Weight
4"	19-1/2"	29"	11-1/4"	15"	120 lb (54 kg)

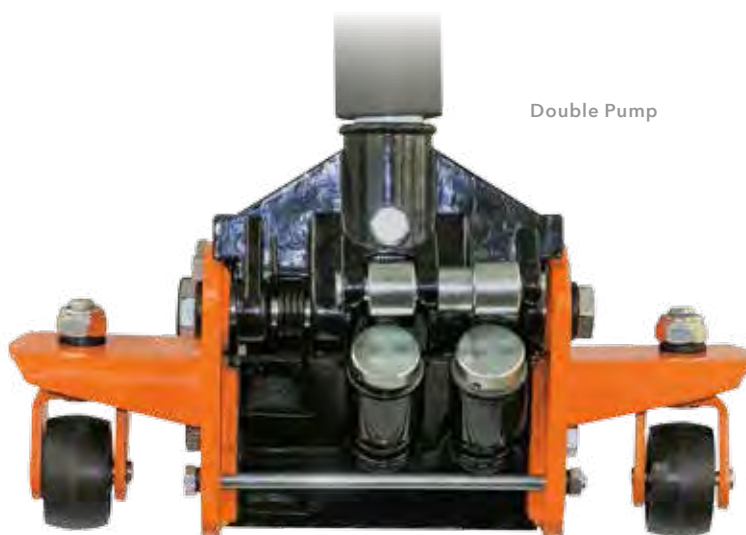

FLOOR/GARAGE JACKS - HYDRAULIC

STRONGARM™

STRONGARM

5 & 10 TON - Long Chassis Service Jacks - Heavy Duty

- Heavy duty manually operated service jack for the most demanding heavy duty applications
- Ideal for truck tire shops, truck repair shops, fleet service, maintenance shops, military bases, job sites and all heavy duty jobs
- Heavy duty pumps, rams, and cylinders are precision machined and inspected to ensure long service life and superior performance
- Designed to get into very low areas • Automatic safety valve prevents overload
- Heavy duty swivel casters provide optimum maneuverability
- Handle mounted locking control lever locks handle in one of three positions: vertical, 45°, or horizontal for more convenient under vehicle positioning
- All models feature a convenient foot pedal for raising

PROD. NO.	MOD. NO.	Cap. (Tons)	Low Height	High Height	Length	Front Width	Rear Width	Shipping Weight
030434	955	5	6"	22-1/2"	59"	11-1/2"	15"	264 lb (119 kg)
030436	957	10	7"	23"	61"	13"	18"	373 lb (168 kg)



5 & 10 TON - Air/Hydraulic Long Chassis Service Jack - Heavy Duty

PROD. NO.	MOD. NO.	Cap. (Tons)	Low Height	High Height	Length	Front Width	Rear Width	Shipping Weight
030461	956	5	6"	22-1/2"	59"	11-1/2"	15"	273 lb (123 kg)
030466	959	10	7"	23"	61"	13"	18"	387 lb (175 kg)

- Same high quality features as the manually operated jacks but designed for use with compressed air systems between 115 - 200 PSI
- Uses 7.8 cu. ft./min. at 180 PSI • May be used with or without air



20 TON - Long Chassis Service Jack - Super Heavy Duty

PROD. NO.	MOD. NO.	Cap. (Tons)	Low Height	High Height	Length	Front Width	Rear Width	Shipping Weight
030438	970SD	20	7-3/4"	23-3/4"	67-1/2"	14-1/2"	19-5/8"	500 lb (225 kg)



20 TON - Air/Hydraulic Service Jack - Super Heavy Duty

- Heavy duty manually operated service jack for the most demanding heavy duty application
- Ideal for truck tire and repair shops, fleet service, maintenance shops, military bases, and job sites
- Heavy duty pumps, rams and cylinders are precision machined and inspected to ensure long service life and superior performance • Designed for access into very low heights
- Automatic safety valve prevents overload, ensuring product durability and your security
- Heavy duty swivel casters provide optimum maneuverability
- Handle mounted locking control lever has 3 positions offering optimum versatility to ensure more convenient and accurate under car positioning

PROD. NO.	MOD. NO.	Cap. (Tons)	Low Height	High Height	Lift Height	Shipping Weight
030439	980SHD	20	7-1/2" (190 mm)	26-3/8" (670 mm)	18-7/8" (480 mm)	679 lb (308 kg)



TRUCK AXLE AIR/HYDRAULIC JACKS

20 TON - Air/Hydraulic Truck Jack - Heavy Duty

030445 / 728C



3 piece adapter kit included as standard accessory

- For over 10 years model 728C has set the Canadian truck tire industry standard
- Corrosion-resistant aluminum and nylon composite air motor
- In-line filter to protect air motor from contaminants
- Heavy duty pump, ram and cylinders are precision machined and inspected to ensure long service life and superior performance
- Heat treated cylinder wall and chrome piston give added stability and longer jack life
- In-line oiler automatically provides lubrication for air motor, extending the life of the jack and overall performance
- Designed for lifting trucks, buses, trailers, and other heavy duty equipment
- Two piece 41" handle
- Operates at 90 - 180 PSI
- Standard accessories: 3 piece adapter kit including 3/4", 2-3/4", and 4" extensions



T-Handle



3 piece adapter kit included as standard accessory

20 TON - Air/Hydraulic Truck Jack - Super Heavy Duty

030448 / 720SD

- Canada's premium quality 20 ton axle jack
- This super duty work horse features a specially heat treated cylinder wall and chrome piston machined to super exacting tolerances ensuring premium performance, durability, life and safety
- Premium air motor lasts longer and is more reliable than competitive brands
- Safety valve prevents damage from overload
- Large diameter wheels assist in maneuverability
- Long T-handle with integrated release assists in jack positioning
- Handle lock allows the handle to be secured in the vertical, 45° or horizontal positions
- Ships in two cartons*

PROD. NO.	MOD. NO.	Cap. (Tons)	Ram Lift	Low Height	High Height	Length	Front Width	Rear Width	Shipping Weight
030445	728C	20	4-3/4"	8-3/4"	17-3/4"	20"	12-1/4"	12-1/4"	98 lb (44 kg)
030448	720SD	20	4-3/4"	8"	17"	20-1/8"	7-3/8"	12-7/8"	100 lb (45 kg)*

TRUCK AXLE AIR/HYDRAULIC JACKS

STRONGARM

STRONGARM

22 TON - Single Stage Air Hydraulic Truck Jack - Super Heavy Duty 030450 / 722SHD

- Super Heavy Duty, single stage 22 ton jack built for a wide variety of demands from the heavy duty trucking, agricultural, fleet, construction and military sectors
- The piston head seal design is borrowed from industrial technology providing a superior low and high pressure seal, giving this jack a much better hold under severe load conditions
- The extra long 138 cm (54") handle can be locked in 3 positions for easy positioning of this jack in hard-to-reach places
- Double polished chromed pistons yield much tighter tolerances which minimize oil bypass and reduce ram scoring
- Fast 2-speed air/hydraulic action advances ram to load faster for quicker, more efficient operation • Includes safety valve for overload protection
- An integral descent metering valve maintains a controlled and safe lowering of the load
- Air assisted lowering as well as 3 self-returning springs for faster ram retraction
- Controlled lowering speeds for increased safety (70mm in 5 sec, under load, 75mm in 5 sec, without load)
- Comes with 3 heat treated extensions (20, 50, 100 mm) for a wide range of lifting options
- Tested to 20,000 cycles for long service life and increased return on investment



3 piece adapter kit included as standard accessory

SERVICE JACKS

PROD. NO.	MOD. NO.	Cap. (Tons)	Low Height	High Height	Rise	Working Air Pressure	Shipping Weight
030450	722SHD	22	215 mm (8-1/2")	356 mm (14")	140 mm (5-1/2")	90 - 120 PSI	86 lb (39 kg)

NEW

SHD





30/15 TON - 2 Stage Air/Hydraulic Truck Jack - Super Heavy Duty 030474 / 730SHD

- The extra light weight and portability makes this the ideal service jack for service vehicles
- 2 stages and lifting capacities of 30 and 15 ton make this a very versatile jack
- The extra long removable handle and rugged rear wheels make for easy positioning of this jack in hard to reach places
- An integral Descent Metering Valve maintains a controlled and safe lowering of the load
- The piston head seal design is borrowed from industrial technology providing a superior low and high pressure seal, giving this jack a much better hold under severe load conditions
- Double polished chromed pistons allow for much tighter tolerances which reduce oil bypassing and reduced ram scoring
- Air assisted lowering speeds up ram retraction
- Built-in overload safety valve prevents damage to unit due to excessive load
- Comes with 2 extensions (75mm & 45mm) and saddle adapter
- Units are tested to -25°C and +45°C as well as off centre loading to ensure a long life under even the harshest conditions

Cap. (Tons)	Low Height	High Height	Lift	Working Air Pressure	Shipping Weight
30	150 mm (5.92")	224 mm (8.82")	74 mm (2.91")	0.8 to 1.0 MPa (116 to 145 PSI)	77 lb (35 kg)
15	150 mm (5.92")	292 mm (11.5")	142 mm (5.59")	-	-



50/25 TON - 2 Stage Air/Hydraulic Truck Jack - Super Heavy Duty 030475 / 750SHD

- Super Heavy Duty, 2 Stage 50 ton and 25 ton built tough for the rigors of the heavy duty trucking, agricultural and fleet business
- The piston head seal design is borrowed from industrial technology providing a superior low and high pressure seal, giving this jack a much better hold under severe load conditions
- The extra long 138cm (54") handle can be locked in 3 positions for easy positioning of this jack in hard to reach places
- An integral Descent Metering Valve maintains a controlled and safe lowering of the load
- Single piece base construction provides superior strength for increased load stability
- Double polished chromed pistons allow for much tighter tolerances which reduce oil bypassing and reduced ram scoring
- Air assisted lowering speeds up ram retraction
- Built-in overload safety valve prevents damage to unit due to excessive load
- Comes with 2 extensions (75mm & 45mm) and saddle adapter
- Units are tested to -25°C and +45°C as well as off centre loading to ensure a long life under even the harshest conditions



Cap. (Tons)	Low Height	High Height	Lift	Working Air Pressure	Shipping Weight
50	215 mm (8.46")	332 mm (13.07")	117 mm (4.61")	0.8 to 1.2 MPa (116 to 174 PSI)	165 lb (75 kg)
25	215 mm (8.46")	446 mm (17.56")	231 mm (9.09")	-	-

60/40/20 TON - 3 Stage Air/Hydraulic Truck Jack - Super Heavy Duty 030476 / 760SHD

- This Super Heavy Duty, 3 Stage 60/40/20 ton Air Hydraulic Jack covers a wide variety of demands from the heavy duty trucking, agricultural, fleet, construction and military sectors
- The piston head seal design is borrowed from industrial technology providing a superior low and high pressure seal, giving this jack a much better hold under severe load conditions
- The extra long 138cm (54") handle can be locked in 3 positions for easy positioning of this jack in hard to reach places
- An integral Descent Metering Valve maintains a controlled and safe lowering of the load
- Single piece base construction provides superior strength for increased load stability
- Double polished chromed pistons allow for much tighter tolerances which reduce oil bypassing and reduced ram scoring
- Air assisted lowering speeds up ram retraction
- Built-in overload safety valve prevents damage to unit due to excessive load
- Comes with 2 extensions (75mm & 45mm) and saddle adapter
- Units are tested to -25°C and +45°C as well as off centre loading to ensure a long life under even the harshest conditions

Cap. (Tons)	Low Height	High Height	Lift	Working Air Pressure	Shipping Weight
60	175mm (6.89")	252mm (9.92")	77mm (3.03")	0.8 to 1.2 MPa (116 to 174 PSI)	165 lb (75 kg)
40	175mm (6.89")	322mm (12.68")	147mm (5.79")	-	-
20	175mm (6.89")	404 mm (15.91")	229mm (9.02")	-	-



80/50 TON - 2 Stage Air/Hydraulic Truck Jack - Super Heavy Duty 030477 / 780SHD

- There isn't much that you won't be able to lift with this Super Heavy Duty 2 Stage Air Hydraulic Jack, heavy duty trucking, agricultural, construction, military, even aircraft - this does it all!
- The piston head seal design is borrowed from industrial technology providing a superior low and high pressure seal, giving this jack a much better hold under severe load conditions
- The extra long 138cm (54") handle can be locked in 3 positions for easy positioning of this jack in hard to reach places
- An integral Descent Metering Valve maintains a controlled and safe lowering of the load
- Single piece base construction provides superior strength for increased load stability
- Double polished chromed pistons allow for much tighter tolerances which reduce oil bypassing and reduced ram scoring
- Air assisted lowering speeds up ram retraction
- Built-in overload safety valve prevents damage to unit due to excessive load
- Comes with 2 extensions (75mm and 45mm) and saddle adapter
- Units are tested to -25°C and +45°C as well as off centre loading to ensure a long life under even the harshest conditions

Cap. (Tons)	Low Height	High Height	Lift	Working Air Pressure	Shipping Weight
80	230 mm (9.06")	340 mm (13.39")	77mm (3.03")	0.8 to 1.2 MPa (116 to 174 PSI)	240 lb (109 kg)
50	230 mm (9.06")	440 mm (17.32")	147mm (5.79")	-	-



SINGLE STAGE AIR/HYDRAULIC SERVICE JACKS

Single Stage Air/Hydraulic Truck Jack - Super Heavy Duty

- This Super Heavy Duty, single stage 30 ton high lift air hydraulic jack covers a wide variety of demands from the heavy duty trucking, agricultural, fleet, construction and military sectors
- The piston head seal design is borrowed from industrial technology providing a superior low and high pressure seal, giving this jack a much better hold under severe load conditions
- The extra-long 138cm (54") handle can be locked in 3 positions for easy positioning of this jack in hard to reach places
- An integral Descent Metering Valve maintains a controlled and safe lowering of the load
- Single piece base construction provides superior strength for increased load stability
- Double polished chromed piston allow for much tighter tolerances which reduce oil bypassing and reduced ram scoring
- Air assisted lowering speeds up ram retraction
- Built-in overload safety valve prevents damage to unit due to excessive load
- Comes with 2 extensions (100 mm and 45 mm) and saddle adapter
- Units are tested to -25°C and + 45°C as well as off centre loading to ensure a long life under even the harshest conditions.
- Pneumatic wheels for easy maneuverability

PROD. NO.	MOD. NO.	Cap. (Tons)	Low Height	High Height	Working Air Pressure
030472	830SHD	30	360 mm	722 mm	116 - 174 PSI
030473	860SHD	60	420 mm	1,031 mm	116 - 174 PSI

030472 **SHD**

030473

NEW
SHD

5-1/2 TON - Long Reach Air Lift Jack - Heavy Duty 030454 / 527

- 5-1/2 ton capacity achieved at 160 PSI air supply
- Eases lifting and lowering of large truck, buses, farm and construction equipment
- Scissor design enables flexibility when lifting
- Includes two sizes of saddles and a drop axle adapter for increased versatility
- Convenient saddle storage on the cylinder
- The drop axle adapter can reduce the minimum height by 3-1/2" in front of the support bar on the jack
- The high saddle adds maximum 10-1/2" height to the support bar on the jack
- The low saddle adds maximum 4-1/2" height to the support bar on the jack
- Five position safety lock that is independent of air pressure
- Two large pneumatic wheels provide excellent maneuverability
- Reach: 45", Saddle spread: 23" - 45"
- Lowered dimensions: 15" W x 77" L x 6-1/2" H

10 TON - Air End Lift Jack - Heavy Duty 030457 / 528

- 10 ton capacity achieved at 200 PSI air supply
- 4" x 6" steel saddles adjust between 36" and 50" widths to accommodate a wide variety of vehicle applications
- Saddle arms reversible for lower lifting points
- Three-way air valve for fine lifting and lowering control
- Automatic mechanical safety lock engages at five lift heights from 17-1/2" to 50"
- Two air control valve fittings – one for shop air supply and one for a Schrader valve
- Front swivel caster and two pneumatic rear tires for easy maneuverability
- 13" forward reach (distance from cylinder to saddles)

PROD. NO.	MOD. NO.	Cap. (Tons)	Saddle Spread	Low Height	High Height	Working Air Pressure	Shipping Weight
030454	527	5-1/2	23" - 45"	6-1/2"	53-1/2"	160 PSI	638 lb (290 kg)
030457	528	10	36" - 50"	12"	39-1/2"	200 PSI	750 lb (341 kg)



AIR LIFT JACKS

10 TON - Air Lift Jack - Heavy Duty

030458 / 529

- 10 ton capacity achieved at 200 PSI air supply
- Heavy duty air valve offers accurate lift control
- Removable T-handle for easy storage
- Extension tubes offer multiple lifting and locking positions
- 12" lift travel
- Large diameter rubber tread wheels for ease in positioning in restricted areas
- Designed for lifting large trucks, buses, farm and construction equipment, especially in crowded service areas

PROD. NO.	MOD. NO.	Cap. (Tons)	Low Height	High Height	Working Air Pressure	Shipping Weight
030458	529	10	18"	42"	200 PSI	172 lb (78 kg)



Raised



Lowered

7 TON - Fork Lift Jack - Heavy Duty

030482 / 958A

- The scissor jack point is low enough to efficiently access and lift a variety of popular forklift models
- Scissors lift from 2-1/2" to 16-1/2"
- 14" reach in raised position
- Safety valve provides critical overload protection
- Rugged wheels make load alignment easier
- Chassis 26" long x 9" wide
- Shipping weight: 150 lb (68 kg)

Clutch Jack - Manual Swivel Head Design - Heavy Duty

030501 / 802A

- A highly efficient design that provides the technician with capabilities to remove, install and transport heavy duty truck clutches
- This heavy duty unit has a greater capacity than most competitive units and has the added versatility of being able to convert the optional adapters for fly wheels, drive shafts, starter motors, auxiliary cases, differentials, brake drums and camel back springs
- Patented clutch head assembly (US patents 5,251, 875, and 5,033,717) turns 360° and pivots side-to-side for efficient clutch/engine alignment
- Two splined alignment shafts (2" OD x 1.18" pilot and 1-3/4" OD x .938" pilot)
- Clutch assemblies can easily be built on the vertical shaft and then positioned easily under the truck
- Pump handle rotates 360° for ease of operation in virtually any work position
- Unique pinned alignment shaft allows technician to remove jack to install clutch assembly without obstruction

Cap. (lb)	Low Height	High Height	Frame Dimensions	Shipping Weight
500	13"	39"	36-1/2" L x 22" W	138 lb (62 kg)

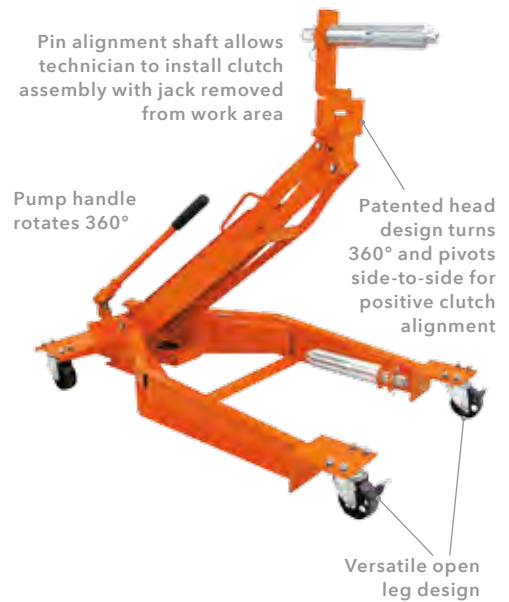

CLUTCH JACK ACCESSORIES

030502 • 802A-1 • Flywheel Adapter

- Easily replaces the spline and bolts onto flat and pot style truck flywheels used with 14" and 15-1/2" clutches for more efficient removal and installation
- Shipping weight: 18.55 lb (8 kg)



030503 • 802A-2 • Drive Shaft Adapter

- Supports heavy truck drive shafts under the main carrier bearing or the complete shaft, allowing one shop technician to safely move or align them
- Shipping weight: 18 lb (8 kg)



030504 • 802A-3 • Starter Motor Adapter

- With its large V shape surface area, it cradles large truck starter motors and makes their removal, installation and transportation easier
- Shipping weight: 11 lb (5 kg)



030505 • 802A-4 • Auxiliary Case Adapter

- Helps technician remove the auxiliary case without having to remove the complete transmission unit
- Shipping weight: 11 lb (5 kg)



030506 • 802A-5 • Differential Adapter

- Makes removing and installing heavy truck differentials easier and safer by eliminating the need for personal heavy lifting by a shop technician
- Shipping weight: 30 lb (14 kg)



030507 • 802A-6 • Brake Drum Adapter

- Works like a forklift to handle heavy truck brake drums. Easily positions under the vehicle to safely remove or install the drum. The tilt and pivot abilities of the head allow for precise brake drum alignment
- Shipping weight: 37 lb (17 kg)



030508 • 802A-7 • Camelback Spring Adapter

- Allows technician to safely remove and efficiently change many Mack truck style camel back spring units
- Shipping weight: 42 lb (19 kg)



030509 • 802A-8 • Spline 1.18" Pilot x 2.00"

- Comes with 802A
- Spline shaft end has flattened sides to allow the use of wrench to turn clutch assembly and is threaded for use with slide hammer for pulling tight spline shafts
- Shipping weight: 6 lb (3 kg)



030510 • 802A-9 • Spline .983" Pilot x 1.75"

- Comes with 802A
- Spline shaft end has flattened sides to allow the use of wrench to turn clutch assembly and is threaded for use with slide hammer for pulling tight spline shafts
- Shipping weight: 6 lb (3 kg)



030511 • 802A-10 • Spline .981" Pilot x 1.50"

- Spline shaft end has flattened sides to allow the use of wrench to turn clutch assembly and is threaded for use with slide hammer for pulling tight spline shafts
- Shipping weight: 6 lb (3 kg)





For single or dual truck wheel assemblies



13-3/4" long rollers allow easy wheel to hub alignment



SPECIALTY TRUCK EQUIPMENT

1,500 lb - Hydraulic Wheel Dolly - Heavy Duty

030484 / 224

- Lift arm adjusts inward and outward to handle different wheel combinations
- Provides extra low access to easily position heavy wheel assemblies
- Leveling screw for precise alignment
- Full 7-3/4" ram lift
- Three large swivel casters provide maximum flexibility of movement
- Six foot safety chain secures wheels in place during removal and transport
- Easily handles the removal, installation and transportation of single or dual truck wheel assemblies

Cap. (lb)	Low Height	High Height	Length	Width	Shipping Weight
1,500	2-1/2"	10-1/4"	31"	43"	166 lb (75 kg)

1.2 TON Large Wheel Dolly

030487 / WDX12

- For removing, transporting, and mounting large off-road tractor/ wheeled excavator tires easily and safely
- Large steel and polyurethane casters provide easy maneuverability
- Foot pedal ensures safety, control and ease of use when lifting and lowering
- Adjustable top stabilizing arm for use on a wide range of tire diameters and widths
- 2 sets of 4 large rollers improve handling of tires with deep treads
- Rugged construction for use in both interior and exterior environments
- Adjustable top stabilizing arm for wide range of tire diameters and widths
- Fast disassembly for easy transport and/or relocation.

Prod. No.	Mod. No.	Capacity	Min. Tire Diameter	Max. Tire Diameter	Max. Tire Cross Section Width	Shipping Weight
030487	WDX12	1.2 Tons (2,400 lb)	39" (1,000 mm)	86" (2,200 mm)	31" (800 mm)	342 lb / 155 kg

450 lb - Wheel Dolly

030485 / 624A

- Suitable for super wide highway tires
- Rugged tubular construction
- 13-3/4" rollers turn and pivot for perfect alignment with hub lugs
- Design enables one person to do the work without excessive lifting or straining
- Shipping weight: 26.5 lb (12 kg)

Break Drum Handler - Heavy Duty

030483 / 623

- Designed for installing, removing and transporting brake drums
- Accommodates 15" to 16-1/2" brake drums
- Rotating handle for easy lowering and raising of drum
- Design allows for easy maneuverability and balance of drum
- Adjustable brackets secure both outboard and inboard mounted drums with disc wheel hubs to the brake drum handler
- Removable handle for easy storage
- Shipping weight: 55 lb (25 kg)

15,000 lb - High Reach Fixed Stands - Super Heavy Duty

- Super Heavy Duty construction, designed for truck and bus support
- Spring loaded caster wheels allow for easy positioning and portability
- Adjustable height range

PROD. NO.	MOD. NO.	Low Height	High Height	Saddle Diameter	Shipping Weight
032215	WTS15H-SHD	57"	82"	5"	134 lb (61 kg)
032216	WTS15L-SHD	36"	57"	5"	103 lb (47 kg)



33,000 lb - High Reach Fixed Stand - Super Heavy Duty 032217 / WTS33H-SHD

- Super Heavy Duty construction, designed for truck and bus support
- Spring loaded caster wheels allow for easy positioning and portability
- Adjustable height range

PROD. NO.	MOD. NO.	Low Height	High Height	Saddle Diameter	Shipping Weight
032217	WTS33H-SHD	56"	82"	5"	232 lb (105 kg)



20 TON - Truck Ramps - Super Heavy Duty 030481 / TR-20ATW

- Long retractable handle eases movement and stores easily out of the way
- Suitable for large truck tires up to 16" maximum width
- Comes with rubber non-skid pad to prevent slippage
- 20 ton capacity per pair

PROD. NO.	MOD. NO.	Product Dimension	Overall Length	Shipping Weight
030481	TR-20ATW	47" x 18.25" x 9.25" (L x W x H)	60"	396 lb (180 kg) pair



STRONGARM



STANDS

STRONGARM Under-Hoist Stands and Stabilizing Stands, built with all steel construction, are designed to stabilize vehicle system components (such as exhausts and suspensions) in under-hoist applications.

2 TON - Under-Hoist Component Stand Tripod Style - Heavy Duty

032202 / 874A

- Adjusts from 55" to 85-1/2"
- Ideal for exhaust and suspension work
- Bearing included for smooth operation
- Easily dismantles for storage
- 24" x 24" x 24" base
- Not designed to support entire vehicle but may be used to stabilize vehicles that are raised by in ground or above ground lifts
- Shipping weight: 44 lb (19 kg)

3/4 TON - Single Post Style - Heavy Duty

032204 / 875A

- Designed to support vehicle components, not vehicles
- Ideal for shock absorber replacement and exhaust system installations
- Adjusts from 54-1/2" to 80-1/2"
- Foot operated lever for extra lift
- Bearing included for smooth operation
- 12" diameter base
- Shipping weight: 32 lb (14 kg)

2 TON - Under-Hoist Stabilizing Stand Tripod Style - Heavy Duty

032206 / 876A

- Features all steel construction with joints welded together for maximum strength
- Stabilizes vehicles that are raised by in ground or above ground lifts
- Adjusts from 66-1/2" to 73"
- Ideal for exhaust and suspension work
- Bearing included for smooth operation
- Adjusting screw for easier load operation
- 21" x 21" x 21" base
- Not designed to support entire vehicle but may be used to stabilize vehicles that are raised by in ground or above ground lifts
- Shipping weight: 26 lb (12 kg)

50 TON - Under-Hoist Stabilizing Stand Screw Type - Heavy Duty

032211 / 877

- Designed for stabilizing loaded and unloaded trailers when not connected to trucks
- Pivoting, reversible ratchet head helps level trailers on uneven ground
- Acme threaded screw design
- 100,000 lb static load capacity
- 45,000 lb lifting capacity
- Heavy duty base secures and stabilizes load
- Removable pipe handle
- Cap Size: 8" diameter
- Base Plate: 14" diameter
- Adjusts from 39" to 51"
- Shipping weight: 125 lb (54 kg)

STRONGARM Jack Stands provide a safe and secure way to support vehicles once lifted and when performing under car maintenance. Our ratchet and pin-type stands are built using heavier steel with large support saddles. They are intended for use in pairs in automotive and fleet service as well as agricultural and construction equipment service facilities.

10 TON - Jack Stands High Profile Set - Heavy Duty

032226 / 871A

- Large support saddle and extra wide four legged base for stability
- 10 height adjusting pin positions
- Sold and shipped in pairs

10 TON - Jack Stands Low Profile Set - Heavy Duty

032228 / 873A

- Large support saddle and extra wide four legged base for stability
- 7 height adjusting pin positions
- Sold and shipped in pairs

PROD. NO.	MOD. NO.	Cap. (Tons)	# of Positions	Low Height	High Height	Saddle Dimensions	Base Dimensions	Shipping Weight
032226	871A	10	10	30-3/4"	46-1/4"	3-1/8" x 5-7/8"	16" x 16"	110 lb (50 kg) pair
032228	873A	10	7	21-1/2"	29-3/4"	3-1/8" x 5-7/8"	17" x 17"	66 lb (30 kg) pair



032226



032228

STRONGARM



032229



032222

Made with superior quality heavy duty cast saddles



032241

Made with heavier gauge steel for maximum strength and safety

STANDS

20 TON - Jack Stand - Heavy Duty

032229 / 878A

- Efficient pin-type post with four height adjustment positions
- Adjusts from 13-3/4" to 19-3/4"
- Large 3" x 3-7/8" saddle
- 10" x 10" square base secures and stabilizes load
- Meets ANSI standards for performance and safety
- Balanced carry handle
- Sold individually
- Must be used in matched pairs

# of Positions	Low Height	High Height	Saddle Dimensions	Base Dimensions	Shipping Weight
4	13-3/4"	19-3/4"	3" x 3-7/8"	10" x 10"	42 lb (19 kg) ea.

5 TON - Forklift Stands - Heavy Duty

032222 / 869A

- Large support saddle
- Heavy duty 9" - 10" rectangular base secures and stabilizes load
- Sold and shipped in pairs
- Must be used in matched pairs

# of Positions	Low Height	High Height	Saddle Dimensions	Base Dimensions	Shipping Weight
4	12-3/4"	16-1/2"	2-3/4" x 4"	9" x 10"	25 lb (11 kg) pair

3-12 TON - Jack Stands - Ratcheting Style - Heavy Duty

- Notched saddles for use with unitized vehicles
- Safety ratchet prevents lowering when saddle is loaded
- Convenient handle for column release and carrying
- Meets ANSI specifications
- Sold and shipped in pairs
- Must be used in matched pairs

PROD. NO.	MOD. NO.	Cap. (Tons)	Low Height	High Height	Base Dimensions	Shipping Weight
032241	853A	3	11"	16"	7" x 7-1/2"	16 lb (7 kg) pair
032243	856A	6	15-1/2"	24"	9" x 10-1/2"	30 lb (14 kg) pair
032246	872B	12	18"	28-3/4"	12" x 10-3/4"	70 lb (32 kg) pair

STRONGARM Hydraulic Telescopic Transmission Jacks provide service technicians one-man capabilities for installing transmissions, differentials or transfer cases.

700 lb - Single Stage Manual Transmission Jack 030522 / 792B

- Economical single stage telescopic ram for use on automobile transmissions, transfer cases or differentials
- Designed for under-hoist work
- Large 360° swivel casters for easy maneuverability
- Adjustable saddle with corner brackets and safety chain



030522

1,000 lb - Two Stage Manual Transmission Jack - Heavy Duty 030524 / 814A

- Two stage manual hydraulic operation
- Universal head provides forward, back and side tilt
- Fully adjustable universal saddle with corner brackets and safety chain
- Foot operated pump allows mechanic to use both hands to position and align saddle with transmission
- Automatic safety valve prevents jack from overload
- Wide base for maximum stability
- 360° handle for extra convenience



030524

PROD. NO.	MOD. NO.	Cap. (lb)	Low Height	High Height	Base Dimensions	Forward Tilt	Backward Tilt	Left Tilt	Right Tilt	Shipping Weight
030522	792B	700	53"	73"	39" sq.	N/A	N/A	N/A	N/A	96 lb (43 kg)
030524	814A	1,000	33-1/2"	72-1/2"	38" sq.	40°	15°	50°	20°	203 lb (91 kg)

TRANSMISSION JACKS



030532

NEW

1,000 lb Two-Stage Air/Hydraulic Transmission Jack - Heavy Duty 030532 / 8178

- STRONGARM Hydraulic Telescopic Transmission Jacks provide service technicians one-man capabilities for installing transmissions, differentials or transfer cases
- Two stage system for maximum speed and precision final positioning
- Four fast ratcheting head brackets ensure you can easily and safely secure transmission pan flanges
- Strong nylon strap ensures secure load anchoring, keeping you safe
- Solid stance with heavy duty, wide swivel casters provide more efficient under-hoist positioning and easy maneuverability on rough floors

PROD. NO.	MOD. NO.	Cap. (lb)	Low Height	High Height	Lift Height	Shipping Weight
030532	8178	1,000	35"	74"	39"	190 lb (86 kg)



030527

2,000 lb - Two Stage Hydraulic Transmission Jack - Heavy Duty 030527 / 816A

- Two stage telescopic ram, designed for heavier automotive and medium duty truck transmissions, transfer cases or differentials in under-hoist applications
- Universal head provides forward, back and side tilt
- Automatic safety valve provides critical overload protection
- Adjustable saddle with corner brackets and safety chain
- Extra wide 4 point base with rugged 360° swivel casters for maximum stability and maneuverability

PROD. NO.	MOD. NO.	Cap. (lb)	Low Height	High Height	Base Dimensions	Forward Tilt	Backward Tilt	Left Tilt	Right Tilt	Shipping Weight
030527	816A	2,000	33-1/2"	72-1/2"	44" sq.	40°	15°	50°	20°	242 lb (109 kg)



030529

Fuel Tank Adapter - Heavy Duty 030529 / 818

- Adjustable brackets, two safety straps, two grounding cables
- 80 lb capacity
- Fits STRONGARM transmission jack models 814A and 816A and 8178
- Measurements: Overall width 15" W., Retracted length 19-3/4", Extended length 31-3/4", Pad size 5-3/4" x 4"
- Shipping weight: 59 lb (27 kg)

1 TON - Low Profile Transmission Jack

030545 / 804A

- Designed for light to medium truck transmissions
- Fully adjustable universal saddle with corner brackets and safety chains
- Safety overload bypass to prevent hydraulic damage
- 24" handle pivots 360° around pump
- 4 industrial grade 3" casters
- Handles on both sides at back of the jack for convenience and maneuverability



030545

1 TON - Low Profile Transmission Jack - Heavy Duty

030547 / 806A

- Designed for heavy truck service
- Adjustable width head plate and wedge shaped brackets allows for a wide range of mounting options and the 4 way tilting head makes for easier removal and installation of the transmission
- Equipped with a 360° swiveling handle for use in tight spots
- Head dimensions: Width - Min. 6-1/2", Max. 18-1/4", Length - Min. 6-3/4", Max. 18-1/2"
- Open leg design makes it very versatile
- Rugged heavy duty casters
- Safety chain included
- Handles on both sides at back of the jack for convenience and maneuverability



030547

2 TON - Low Profile Transmission Jack - Super Heavy Duty

030549 / 808A

- STRONGARM offers the only Super Heavy Duty transmission jack with a full 2 ton capacity
- Built to handle removal, transport and installation of transmissions, transfer cases or differentials on heavy duty trucks, buses, agricultural and construction equipment
- Fully adjustable saddle with maximum tilt for easier alignment
- Adjustable corner brackets
- Convenient side trays for small tools and parts
- Safety overload bypass system to prevent hydraulic damage
- Adjustable saddle with corner brackets and safety chain
- 32" handle pivots 360° around pump
- Rugged industrial grade 4" casters for maximum maneuverability



030549

PROD. NO.	MOD. NO.	Cap. (Tons)	Low Height	High Height	Base Dimensions	Forward Tilt	Backward Tilt	Side Tilt	Shipping Weight
030545	804A	1	5-3/4"	31-1/2"	18-1/2" W. x 37-1/2" L.	65°	10°	12°	143 lb (64 kg)
030547	806A	1	10"	44"	25" W. x 53" L.	40°	25°	12°	299 lb (135 kg)
030549	808A	2	8-1/2"	34"	26" W. x 43" L.	15°	30°	12°	297 lb (166 kg)

STRONGARM



ENGINE STANDS

STRONGARM Engine Stands are used in the positioning and transportation of automobile and light truck engines in a wide variety of vehicle service facilities. All Engine Stands include a 360° rotating head, which efficiently puts the engine in the optimal work position, rugged full swivel casters and heavy duty tubular steel construction. Superior welds in all locations provide maximum strength and durability.

1,000 lbs - H-Design**030352 / 234B**

- Wide 4 point H type base ensures good stability
- 4 Adjustable brackets provide maximum flexibility – fits most small engines
- 360° rotating head enables engine to be placed in desired work position
- 2 fixed rear wheels and 2 front swivel casters
- Heavy duty welded reinforced steel base

Cap. (lbs)	Base Length	Stand Height	Front Width	Rear Width	Shipping Weight
1,000	36"	34-3/4"	31"	N/A	53 lb (24 kg)

**1,250 lbs - U-Design****030353 / 236A**

- Extra wide 4 point U type base ensures maximum stability and performance
- Adjustable brackets allow maximum flexibility – fits most automobile and light truck engines
- 360° rotating head enables engine to be placed in desired work position
- Full swivel casters
- Heavy duty welded steel base
- Features convenient tray for holding tools and parts

Cap. (lbs)	Base Length	Stand Height	Front Width	Rear Width	Shipping Weight
1,250	34"	34"	33"	33"	83 lb (37 kg)

STRONGARM Engine Cranes are designed for easy and efficient removal and transportation of vehicle engines. All feature four-position telescopic booms, wide stable bases, forged steel hooks with safety latches and heavy duty swivel casters. Superior welds in all locations provide maximum strength and durability.

1/2 TON (1,000 lb) - 360° Swivel Truck Mounted Crane - Heavy Duty 030303 / 200A

- Rugged steel construction
- Boom working range 26.75" to 41.25"
- Locking 360° swivel base
- Heavy duty chain with safety lock
- Designed to be installed in pickup truck beds or vans
- Shipping Weight: 106 lb (48 kg)



Extends from 43" to 64"

Foldable for extra storage and portability!

2 TON (4,000 lb) - Telescoping Crane - Folding Style - Heavy Duty 030315 / 216

- Designed for shops with limited space and for maximum portability
- Ideal for rental yards
- The legs easily fold up and away and with the ram completely retracted, this uses an extremely small storage footprint
- 360° hook adds greater flexibility in positioning lifting chains during removal and installation
- Shipping Weight: 260 lb (117 kg)



Boom Extensions

Position	Capacity (Tons)	Length*	Height**
1	2	43"	87"
2	1-1/2	54"	92"
3	1	57"	94"
4	1/2	64"	102"

* Measured from ram attachment to boom end

** Measured at maximum ram extension



4 different boom settings:
3T, 2T, 1.5T, 1T



CRANES - HYDRAULIC

3 TON - Engine Crane - Heavy Duty

030321 / 218

- Extra heavy duty engine crane with reinforced leg assemblies for added strength and durability
- 4 different boom settings: 3T, 2T, 1.5T, 1T
- Hydraulic ram has built in safety overload to protect the unit from being used beyond its rated capacity
- Large 4.25" rear swivel casters and 6" fixed front wheels provide ease of mobility and positioning
- Shipping Weight: 359 lb (163 kg)

Boom Extensions

Position	Capacity (Tons)	Length*	Height**
1	3	32"	70"
2	2	34"	74-1/2"
3	1-1/2	44"	80-1/2"
4	1	56"	82"

* Measured from ram attachment to boom end

** Measured at maximum ram extension

3/4 TON (1,500 lb) - Engine Tilter - Heavy Duty

030341 / 209

- Engine can be tipped to a wide variety of angles for easy removal and installation
- Saves time and labour
- Easily change centre of gravity to make engine removal or installation faster and safer
- Can be used with shop cranes and hoists
- Shipping Weight: 13 lb (6 kg)

750 lb - Engine Support

030342 / 238

- Ideal for transverse mounted engines when working on the transmission or when removing engine mounts
- Precisely positions the engine to allow easy transmission removal
- Perfect for front wheel drive vehicles, both 4 and 6 cylinders
- Can be extended to adapt to the width of the vehicle
- Special feature provides height adjustment after having been attached to the engine by means of a worm screw (not intended for lifting engine)
- Shipping Weight: 37 lb (17 kg)

SHOP PRESSES





Pressing adapter set with all models



Quality features standard on all SHD models

- Welded frame for added strength
- Protective guard, combination V block and pressing adapter set included
- Press head moves from side to side for added pressing flexibility
- Liquid filled gauge accurately shows operator pressing force being applied
- Air pressure 110 - 120 PSI

20 TON Shop Press - Super Heavy Duty

032181 / SP20T-SHD

Ram Stroke	Hydraulic System Pressure	Overall Size	Bed Depth	Bed Width	Throat Depth	Throat Width	Shipping Weight
7.5"	10,000 PSI	35" x 64"	7"	19.25"	5.75"	10.75"	282 lb (128 kg)

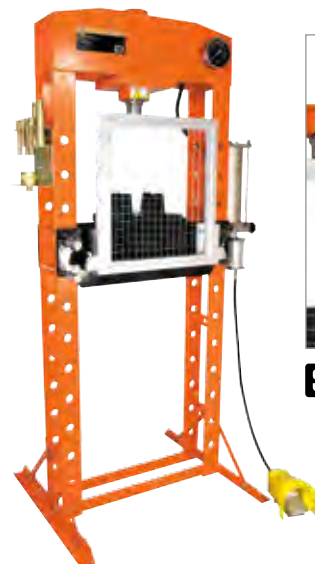

Protective guard with all models



30 TON Shop Press - Super Heavy Duty

032182 / SP30T-SHD

Ram Stroke	Hydraulic System Pressure	Overall Size	Bed Depth	Bed Width	Throat Depth	Throat Width	Shipping Weight
5.9"	8,484 PSI	40" x 71"	7.25"	21.5"	6.5"	15"	363 lb (165 kg)

50 TON Shop Press - Super Heavy Duty

032184 / SP50T-SHD

Ram Stroke	Hydraulic System Pressure	Overall Size	Bed Depth	Bed Width	Throat Depth	Throat Width	Shipping Weight
7.75"	9,053 PSI	54" x 75"	10.125"	28.75"	7.25"	16.75"	660 lb (300 kg)



HD cable winch for raising and lowering press bed (50 and 75 ton only)



75 TON Shop Press - Super Heavy Duty

032185 / SP75T-SHD

Ram Stroke	Hydraulic System Pressure	Overall Size	Bed Depth	Bed Width	Throat Depth	Throat Width	Shipping Weight
9.75"	8,690 PSI	57" x 77"	10.875"	31.5"	8"	19.75"	1,038 lb (472 kg)

HD cable winch for raising and lowering press bed (50 and 75ton only)



100 TON - Shop Press - Super Heavy Duty

032187 / SP100TASHD

- Secondary air motor for fast retraction of ram (on 100 ton only)
- Air Pressure: 120 - 200 PSI (on 100 ton only)

Ram Stroke	Hydraulic System Pressure	Overall Size	Bed Depth	Bed Width	Throat Depth	Throat Width	Shipping Weight
11.8"	9,237 PSI	55" x 84"	13.5"	31"	9"	16.5"	1,476 lb (671 kg)



SHOP PRESS

Accessories / Replacement Parts

- PCN-SP20TSHD-28** • For Model SP20TSHD • **V Block**
- PCN-SP30TSHD-12** • For Model SP30TSHD • **V Block**
- PCN-SP50TSHD-24** • For Model SP50TSHD • **V Block**
- PCN-SP75TSHD-24** • For Model SP75TSHD • **V Block**
- PCN-SP100TASHD-19** • For Model SP100TASHD • **V Block**



SHOP PRESSES

STRONGARM Shop Presses are used in repair shops for the removal and installation of gears, bushings and bearings, as well as with metal bending, straightening, compression and flattening applications. All floor presses have rugged structural steel frames and two V blocks.

12 TON - Manual Hydraulic Shop Press

032161 / 112

- Designed for light duty applications
- Eight level bed adjustment
- 12 ton bottle jack with overload protection
- Heavy duty return springs for fast ram retraction
- Comes with 2 V blocks (6" x 6" x 1/2")
- 20 1/4" W x 51 3/4" H

Ram Travel	# Bed Adjust.	Space Interval	Distance Between Posts	Bed Depth	Throat Width	Throat Depth	Shipping Weight
6-1/4"	8	3-1/2"	16-3/4"	7"	14"	3-1/4"	110 lb (50 kg)

20 TON - Manual Hydraulic Shop Press

032166 / 120A

- Front mounted gauge shows operator the amount of pressure being applied to work piece
- Comes with 20 ton bottle jack/gauge, combination V blocks and plate supports
- Rugged construction suited for industrial use
- Eight bed adjustments
- Comes with 2 V blocks (11" x 4-1/4" x 1")
- 26-3/4" W x 61-1/2" H

Ram Travel	# Bed Adjust.	Space Interval	Distance Between Posts	Bed Depth	Throat Width	Throat Depth	Shipping Weight
5"	8	5"	23"	10"	19-1/2"	6"	288 lb (130 kg)

35 TON - Air/Hydraulic - Heavy Duty Shop Press

032173 / 135

- For automotive and heavy duty use
- Two speed hand pump provides faster travel to load while the air/hydraulic (with overload protection) allows for effortless operation
- Seven bed adjustments
- Frame mounted hydraulic pressure gauge
- Comes with 2 V blocks (12" x 3" x 2")
- 32" W x 69" H

Ram Travel	# Bed Adjust.	Space Interval	Distance Between Posts	Bed Depth	Throat Width	Throat Depth	Shipping Weight
6-1/2"	8	4-1/2"	24"	12"	9"	7-1/2"	312 lb (140 kg)



50 TON - Air/Hydraulic - Heavy Duty Shop Press

032175 / 150

- Designed for heavy duty automotive and industrial use
- Utilizes a secondary manual volume pump to provide faster ram travel and the added versatility of an air motor for greater operator ease
- Frame mounted hydraulic pressure gauge
- Winch operated press bed
- Comes with 2 V blocks (14-1/2" x 3" x 2")
- 60" W x 67" H

Ram Travel	# Bed Adjust.	Space Interval	Distance Between Posts	Bed Depth	Throat Width	Throat Depth	Shipping Weight
7-1/4"	6	5-1/2"	32"	15"	7"	9-1/2"	645 lb (290 kg)



SHOP PRESSES

Accessories / Replacement Parts

12NP04 • For Model 112 (2 required) • **V block**

120AP07A • For Model 120 (2 required) • **V block**

135P9 • For Model 135 • **V block**

150P23 • For Model 150 • **V block**

COLLISION REPAIR

STRONGARM 4, 10 and 20 ton body and frame repair kits are typically used in vehicle maintenance and collision repair facilities.



4 TON - Body Repair Kit - Heavy Duty

030202 / BRK-4T

KIT INCLUDES:

- Hydraulic hand pump • 4 ton heavy duty ram with 4" stroke • 5' Hydraulic hose with spring guards on both ends • 5 Quick connect extensions – 3-1/4", 5", 8-1/2", 16-1/2", 19-1/2" • 1/2 ton spreader ram • Rubber head, wedge head, spreading toe and plunger toe, flat base, V-base, quick connector
- Steel bar handle provides added strength
- Pump core treated for tighter tolerances and added durability
- Bronzed piston head bushing minimizes cylinder damage from side loading
- Upgraded o-rings and secondary o-rings provide for a superior seal and longer life
- Convenient blow mould case
- Shipping weight: 43 lb (19 kg)



10 TON - Body Repair Kit - Heavy Duty

030207 / BRK-10T

KIT INCLUDES:

- Hydraulic hand pump • 10 ton heavy duty ram with 5" stroke • 5' Hydraulic hose with spring guards on both ends • 4 Quick connect extensions – 4.25", 10", 14", 20" • 1/2 ton spreader ram • Rubber head, wedge head, spreading toe and plunger toe, flat base, V-base, quick connector
- Steel bar handle provides added strength
- Pump core treated for tighter tolerances and added durability
- Bronzed piston head bushing minimizes cylinder damage from side loading
- Upgraded o-rings and secondary o-rings provide for a superior seal and longer life
- Convenient blow mould case
- Shipping weight: 69 lb (31 kg)

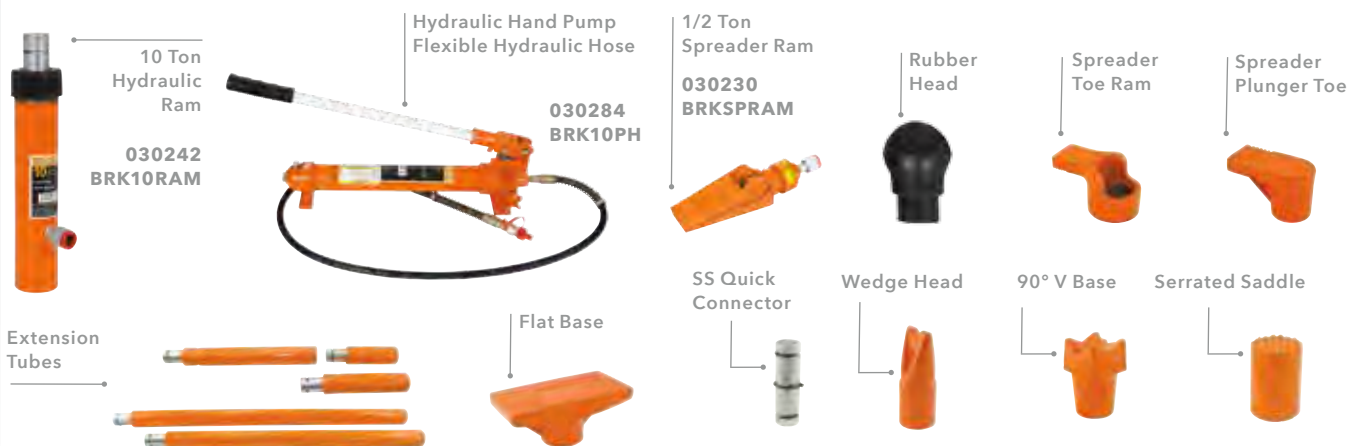

20 TON - Collision Repair Kit - Super Heavy Duty

030250 / BRK20T-SHD

- 20 ton deluxe collision repair kit used in the trucking, farm and construction industry
- 2 speed 10,000 PSI pump with safety overload extends the ram to load quickly
- 20 ton ram with 5" stroke
- All components use a threaded connection for added strength and durability
- 5' flexible hose comes with spring guards at both ends
- Comes with 2 metal carry boxes for added mobility and accessibility
- Shipping weight: 108 lb (49 kg)

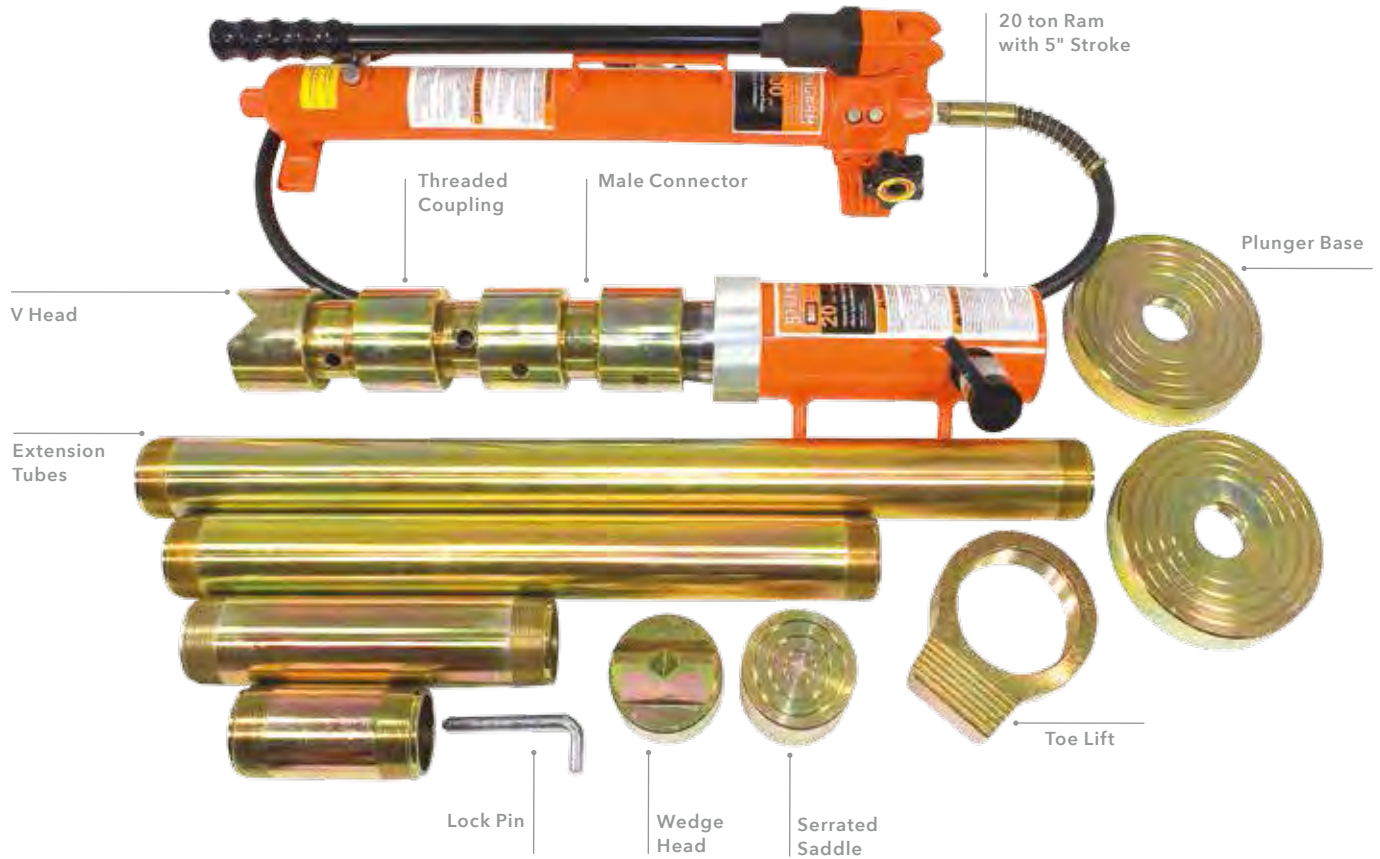



030283



1/4" NPT

030284



54 oz. oil capacity

030212



030215

HAND PUMPS

STRONGARM Air/Hydraulic Hand and Foot Pumps are precision made with the highest quality material and components providing a durable unit for years of service. Each unit produces 10,000 PSI with overload protection.

4 TON - Hydraulic Hand Pump - Heavy Duty

030283 / BRK4PH

- Manual hydraulic pump
- Overload protection
- Oil capacity – 350ml

10 TON - Hydraulic Hand Pump - Heavy Duty

030284 / BRK10PH

- Manual hydraulic pump
- Overload protection
- Oil capacity – 500ml
- 5' Hose, 10,000 PSI working pressure 20,000 PSI burst pressure
- Spring guards on both ends of hose prevents kinking

FOOT PUMPS

STRONGARM Air/Hydraulic Foot Pumps convert rams from manual hand pump operations to air/hydraulic operation for increased efficiency and operator comfort. Can be used on STRONGARM rams as well as other brands up to a 10 ton capacity.

10,000 PSI 20 oz. - Air/Hydraulic Foot Pump - Heavy Duty

030212 / 401A

- Operates at 90 - 120 PSI
- Develops up to 10,000 PSI pressure with overload protection
- 17-1/2" length
- 20 oz. oil capacity
- Shipping weight: 12 lb (5 kg)

10,000 PSI 54 oz. - Air/Hydraulic Foot Pump - Heavy Duty

030215 / 402A

- Operates at 90 - 140 PSI
- Develops up to 10,000 PSI pressure with overload protection
- Can be used with large diameter and multiple rams
- 10" L x 5-1/4" W x 8-1/2" H (tank is 4-1/2" H)
- 54 oz. oil capacity - aluminum reservoir
- Shipping weight: 20 lb (9 kg)

NEW

Hydraulic Rams - Heavy Duty

STRONGARM Hydraulic Rams are professional quality, designed to provide trouble free service to meet a wide range of needs. They are used to provide 2 to 10 tons of reliable, concentrated force in lifting, pulling, pushing, bending and alignment applications. STRONGARM ram models include mini, snap-style, screw, pull, wedge, and long configurations that can be used with STRONGARM and other body and frame repair kits as well as in vehicle service facilities, farms, industry and construction.

PROD. NO.	MOD. NO.	Cap. (Tons)	Ram type	Stroke	Compressed	Extended	Spring return	Shipping Weight
030232	409A	2	Push	3"	4-7/8"	9-9/16"	No	2 lb (1 kg)
030234	411A	4	Push	5"	11"	16"	Yes	4 lb (2 kg)
030239	437A	4	Push	5/8"	1-5/8"	2-1/4"	No	2 lb (1 kg)
030235	412A	10	Push	6"	15"	21"	Yes	12 lb (5 kg)
030240	438A	10	Push	2-1/4"	4-5/8"	6-7/8"	Yes	6 lb (3 kg)

Push Rams - Heavy Duty

PROD. NO.	MOD. NO.	Capacity (Tons)	Stroke	Compressed	Extended
030241	BRK4RAM	4	4"	267mm / 10.5"	14.5"
030242	BRK10RAM	10	5"	318mm / 12.5"	17.5"

Manual Long Rams - Heavy Duty

STRONGARM Long Ram Jacks are available in 3 and 8 ton capacities in both manual hand pump and air/hydraulic versions. Ideal for a multitude of applications such as floor model engine cranes and trailer jacks. All models have a clevis pin system pre-drilled into piston shaft for use on cranes.

PROD. NO.	MOD. NO.	Cap. (Tons)	Type	Stroke	Compressed	Extended	Shipping Weight
030371	403C	3	Manual	20-3/4"	24-1/4"	45"	27 lb (12 kg)
030381	408C	8	Manual	20-3/4"	24-1/4"	45"	37 lb (17 kg)

10,000 PSI - Hydraulic Hose

030292 / BRKH

- 5' Hose
- 10,000 PSI working pressure / 20,000 PSI burst pressure
- Spring guards on both ends of hose prevents kinking





PROclub

BECOME A MEMBER

PROclub is an exclusive club built for professional workers like you. Members are first to hear about tools, equipment, and safety gear for the entire range of SureWerx brands. Activate your membership by visiting yourproclub.com and join Canada's premiere tool and safety community!

WHY JOIN?

- Take advantage of exclusive promotions
- Receive flyer deals
- New product sneak peeks
- Play interactive games
- Receive monthly newsletters
- Watch product videos and tutorials
- Enter contests to win prizes

JOIN PROCLUB TODAY AT YOURPROCLUB.COM



INDUSTRIAL PUMPS & RAMS

NEW





INDUSTRIAL

SINGLE ACTING CYLINDERS

Capacity 5-95 TON

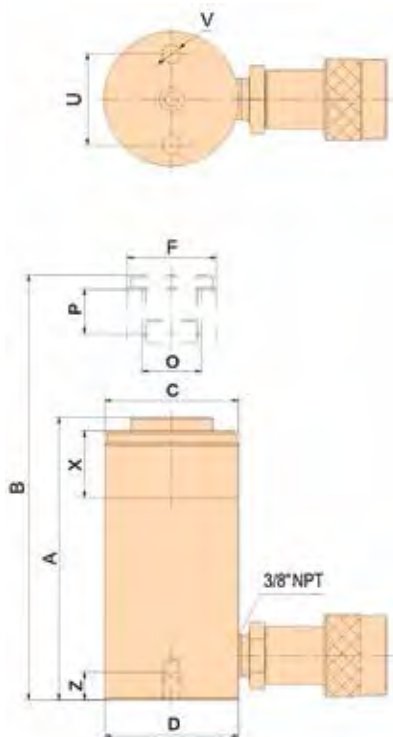

PRODUCT NO.	MODEL NO.	Capacity	Stroke	Cylinder Effective Area	Oil Capacity
		@ 700 Bar (10,000 PSI)			
		Metric Ton (US Ton)	In	In ²	In ³
033001	SACS50	5 (5.5)	0.63	1.10	0.70
033005	SACS55	5 (5.5)	5.00	1.10	5.50
033010	SACS102	10 (11)	2.13	2.25	4.78
033011	SACS104	10 (11)	4.13	2.25	9.29
033012	SACS106	10 (11)	6.14	2.25	13.80
033013	SACS108	10 (11)	7.99	2.25	17.96
033014	SACS1010	10 (11)	10.12	2.25	22.73
033035	SACS252	25 (27.5)	1.97	5.15	10.13
033036	SACS254	25 (27.5)	4.02	5.15	20.66
033037	SACS256	25 (27.5)	6.22	5.15	32.00
033038	SACS258	25 (27.5)	8.27	5.15	42.53
033039	SACS2510	25 (27.5)	10.28	5.15	52.86
033050	SACS506	50 (55)	6.26	10.99	68.77
033060	SACS1006	95 (104.7)	6.61	20.62	136.30

- Complies with ASME B-30.1
- High strength alloy steel for safety and durability
- Inside cylinder treated to enhance durability
- Features collar threads, plunger threads and base mounting holes for optional fixture attachments
- Heavy duty plunger spring return
- High quality 3/8"-18 NPT quick coupling
- Baked enamel finish for increased corrosion resistance





INDUSTRIAL

SINGLE ACTING CYLINDERS

Capacity 5-95 TON

Collapsed Height	Extended Height	Collar Thread	Collar Thread Length	Outside Diameter	Piston Rod Diameter	Piston Internal Thread	Piston Thread Length	Base Fixturing Holes			Product Weight
								Bolt Circle U	Thread V	Thread Depth Z	
A	B	C	X	D	F	O	P	In	In	In	lb / kg
In	In	In	In	In	In		In	In	In	In	
1.65	2.28	-	-	2.32 x 1.65	0.98	-	-	1.10	0.22	-	1.8 / 0.8
8.46	13.46	1-1/2 - 16	1.10	1.50	0.98	3/4 - 16UNF	0.63	0.98	1/4 - 20UNC	0.55	3.7 / 1.7
4.76	6.89	2-1/4 - 14	1.02	2.25	1.50	1 - 8UNC	0.75	1.54	5/16 - 18UNC	0.47	3.7 / 1.7
6.73	10.87	2-1/4 - 14	1.02	2.25	1.50	1 - 8UNC	0.75	1.54	5/16 - 18UNC	0.47	6.4 / 3
9.72	15.87	2-1/4 - 14	1.02	2.25	1.50	1 - 8UNC	0.75	1.54	5/16 - 18UNC	0.47	9.0 / 4.1
11.73	19.72	2-1/4 - 14	1.02	2.25	1.50	1 - 8UNC	0.75	1.54	5/16 - 18UNC	0.47	10.8 / 4.9
13.74	23.86	2-1/4 - 14	1.02	2.25	1.50	1 - 8UNC	0.75	1.54	5/16 - 18UNC	0.47	12.3 / 5.6
6.50	8.46	3-5/16 - 12	2.13	3.39	2.24	1-1/2 - 16UN	1.02	2.28	1/2 - 13UNC	0.75	13.6 / 6.2
8.46	12.48	3-5/16 - 12	2.13	3.39	2.24	1-1/2 - 16UN	1.02	2.28	1/2 - 13UNC	0.75	17.6 / 8
10.75	16.97	3-5/16 - 12	2.13	3.39	2.24	1-1/2 - 16UN	1.02	2.28	1/2 - 13UNC	0.75	22.7 / 10.3
12.72	20.98	3-5/16 - 12	2.13	3.39	2.24	1-1/2 - 16UN	1.02	2.28	1/2 - 13UNC	0.75	26.6 / 12.1
14.72	25.00	3-5/16 - 12	2.13	3.39	2.24	1-1/2 - 16UN	1.02	2.28	1/2 - 13UNC	0.75	31.0 / 14.1
11.10	17.36	5 - 12	2.17	5.00	3.15	-	-	3.74	1/2 - 13UNC	0.75	48.8 / 22.1
14.06	20.67	6-7/8 - 12	1.73	6.97	4.13	-	-	5.47	3/4 - 10UNC	0.98	131.3 / 159.6

1. Guide ring eliminates over travel, and provides support to reduce wear from off-centre loads.
2. Heavy duty wiper ring keeps dust and debris out of cylinder body, improving performance and service life.
3. Bearing ring provides additional support to reduce wear from off-centre loads.
4. All-steel body with baked enamel finish for durability.
5. Hardened and chromed piston increases durability and reduces wear.
6. Secondary gasket and industrial seal ring assembly prevents costly leaks.
7. Standard coupler on all cylinders provided with heavy duty dust cover.
8. High strength return spring.

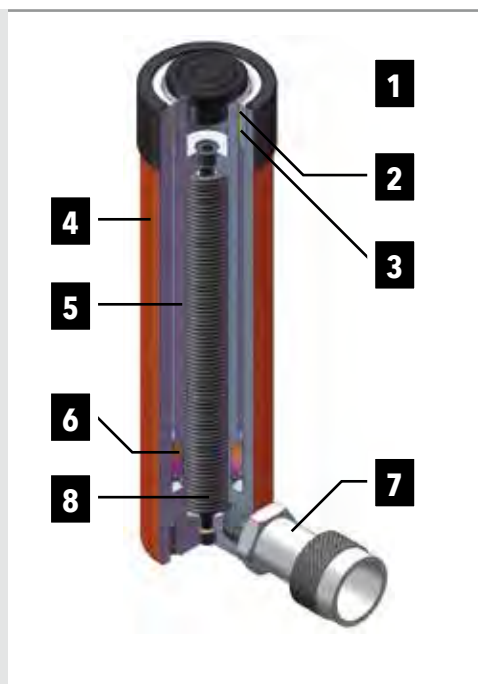



LOW HEIGHT SINGLE ACTING CYLINDERS

CAPACITY 5-50 TON



- For use in confined spaces
- Complies with ASME B-30.1
- High strength alloy steel for durability
- Mounting holes for fixture attachment
- Heavy duty plunger return springs
- High quality 3/8"-18NPT quick coupling
- Grooved plunger end with threaded hole for mounting tilt saddles
- Baked enamel finish for increased corrosion resistance



INDUSTRIAL

**LOW HEIGHT
SINGLE ACTING CYLINDERS**

Capacity 5-50 TON

1. Steel guide ring eliminates over travel and withstands full dead-end load, it also provides support to reduce wear from off-centre loads.
2. Hardened and chromed piston increases durability and reduces wear.
3. All-steel body with baked enamel finish for durability.
4. High strength return spring.
5. Secondary gasket and industrial seal ring assembly prevents costly leaks.
6. Standard coupler on all cylinders provided with heavy duty dust cover.

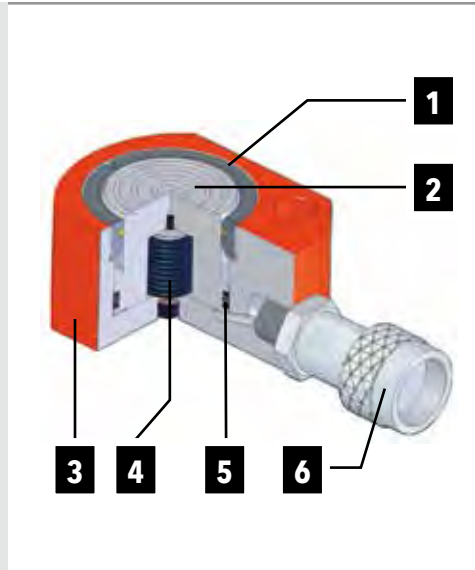

PROD NO.	MOD NO.	Cylinder Capacity @ 700 Bar (10,000 PSI)	Stroke	Cylinder Effective Area	Oil Capacity	Collapsed Height	Extended Height	Outside Diameter	Piston Rod Diameter	Top Dimensions				Product Weight
						A	B			D	F	M	L	
		Metric Ton (US Ton)	In	In ²	In ³	In	In	In	In	In	In	In	In	lb / kg
033061	SACL50	5 (5.5)	0.24	1.10	0.26	1.30	1.54	2.32 x 1.65	0.98	0.91	0.83	0.22	1.12	1.30 / 0.6
033063	SACL100	10 (11)	0.39	2.25	0.88	1.65	2.09	3.27 x 2.20	1.50	1.34	1.10	0.28	1.44	3.30 / 1.5
033065	SACL200	20 (22)	0.43	4.39	1.90	2.01	2.44	3.98 x 3.00	2.01	1.57	1.57	0.39	1.94	5.90 / 2.7
033070	SACL300	30 (33)	0.51	6.48	3.31	2.30	2.80	4.61 x 3.74	2.60	1.77	1.89	0.39	2.05	9.50 / 4.3
033074	SACL500	50 (55)	0.63	9.86	6.21	2.64	3.27	5.51 x 4.49	2.76	2.13	2.24	0.43	2.62	14.70 / 6.7

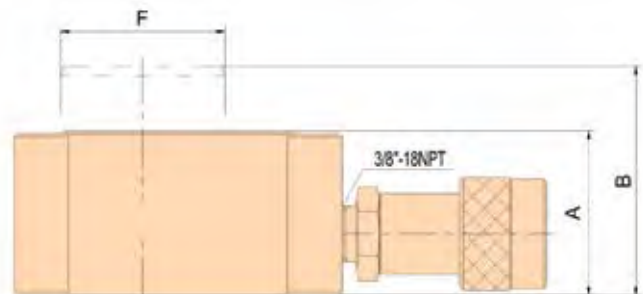
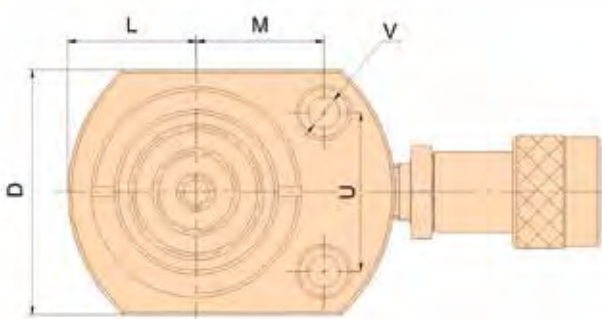

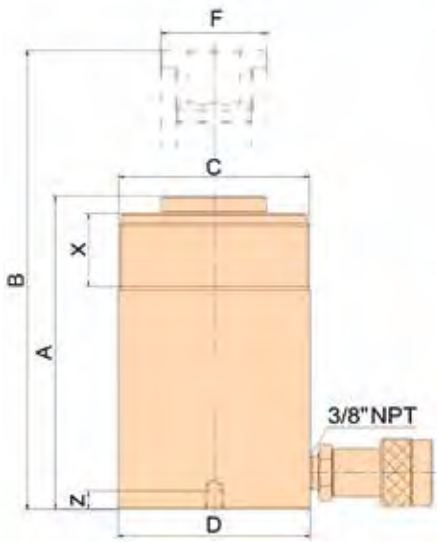
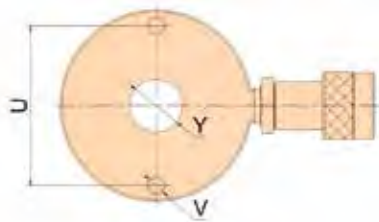

INDUSTRIAL

**HOLLOW CENTRE
SINGLE ACTING CYLINDERS**

Capacity 20-30 TON

- Hollow plunger design allows for both push and pull forces
- Complies with ASME B-30.1
- High strength alloy steel for durability and added safety
- Single acting spring return
- High quality 3/8"-18NPT quick couplings
- Collar and plunger threads for fixture attachment
- Baked enamel finish for corrosion resistance

PROD NO.	MOD NO.	Cylinder Capacity @ 700 Bar (10,000 PSI)	Stroke	Cylinder Effective Area	Oil Capacity
		Metric Ton (US Ton)	In	In ²	In ³
033076	SACH202	20 (22)	1.93	5.08	9.80
033077	SACH206	20 (22)	6.10	5.08	31.01
033078	SACH302	30 (33)	2.52	7.39	18.62
033079	SACH306	30 (33)	6.10	7.39	45.10



INDUSTRIAL

**HOLLOW CENTRE
SINGLE ACTING CYLINDERS**

Capacity 20-30 TON

1. Steel guide ring eliminates over travel and withstands full dead-end load, it also provides support to reduce wear from off-centre loads.
2. Bearing ring provides additional support to reduce wear from off-centre loads.
3. Hardened and chromed piston increase durability and reduces wear.
4. High strength return spring.
5. All steel body with baked enamel finish for durability.
6. Industrial bearing ring provides additional support to reduce wear from off-centre loads.
7. Industrial seal ring assembly prevent costly leaks.
8. Standard coupler on all cylinders provided with heavy duty dust cover.

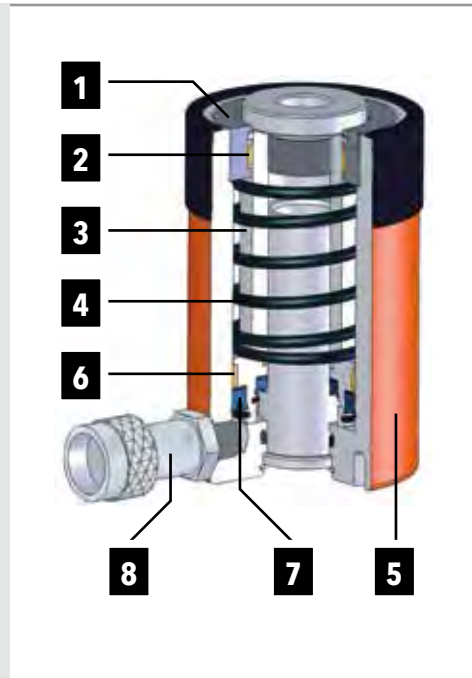

Collapsed Height A	Extended Height B	Collar Thread C	Collar Thread Length X	Outside Diameter D	Piston Rod Diameter F	Base Fixturing Holes			Centre Hole Diameter Y	Product Weight
						Bolt Circle U	Thread V	Thread Depth Z		
In	In	In	In	In	In	In	In	In	In	lb / kg
6.38	8.31	3-7/8-12	1.50	3.90	2.17	3.25	3/8-16UNC	0.37	1.06	16.06 / 7.3
12.05	18.15	3-7/8-12	1.50	3.90	2.17	3.25	3/8-16UNC	0.37	1.06	29.48 / 13.4
7.01	9.53	4-1/2-12	1.65	4.53	2.56	3.63	3/8-16UNC	0.55	1.31	23.10 / 10.45
12.99	19.09	4-1/2-12	1.65	4.53	2.56	3.63	3/8-16UNC	0.55	1.31	42.46 / 19.3



INDUSTRIAL

AIR/HYDRAULIC FOOT PUMPS

- Can be used with a variety of hydraulic cylinders, presses or other hydraulic equipment
- Provides up to 10,000 PSI of hydraulic pressure (0.6 - 1.0 Mpa)
- Air exhaust muffler for quiet operation
- Internal load limiting device provides overload protection
- Air input port thread 1/4" NPT, Oil output 3/8"-18NPT
- Features both air and oil filters to reduce risk of damage from environmental contaminants

PRODUCT NO.	MODEL NO.	Pressure Rating	Air Source Pressure	Usable Oil Capacity	Flow		Dimensions			Reservoir Material	Control Method	Product Weight
					No Load	Load	L	W	H			
		PSI	PSI	IN ²	In ³ /Min		In	In	In			lb / kg
033125	AHP002	10,000	90-145	98	49.5	7.6	10.3	5.3	7.3	Aluminum alloy	Foot pedal	19 / 9
033126	AHP003	10,000	90-145	275	49.5	7.6	12.5	7	7.5	Steel	Foot pedal	28 / 13
033127	AHP004	10,000	90-145	442	49.5	7.6	11	8.8	10	Steel	Foot pedal	36 / 16

AIR/HYDRAULIC FOOT PUMP SELECTION

PROD NO.	MOD NO.	Stage	Flow (In ³)	Capacity (Tons)								
				5	10	15	25	30	50	75	100	150
				Required time (seconds) for cylinder to lift 1 inch								
033125	AHP002	Low Pressure	0.81	1.30	2.90	3.90	6.40	8.30	15.00	19.50		
		High Pressure	0.12	8.70	19.00	26.30	42.50	55.00	100.00	130.00		
033126	AHP003	Low Pressure	0.81	1.30	2.90	3.90	6.40	8.30	15.00	19.50	25.60	
		High Pressure	0.12	8.70	19.00	26.30	42.50	55.00	100.00	130.00	166.00	
033127	AHP004	Low Pressure	0.81	1.30	2.90	3.90	6.40	8.30	15.00	19.50	25.60	38.00
		High Pressure	0.12	8.70	19.00	26.30	42.50	55.00	100.00	130.00	166.00	252.50



INDUSTRIAL

SINGLE ACTING HAND PUMPS

- Single acting hand pumps made of high strength alloy steel; corrosion resistant and engineered for use in extreme environments
- Internal pressure relief valve for overload protection
- Compact design for storage and transportation
- Compatible with various cylinders and tools

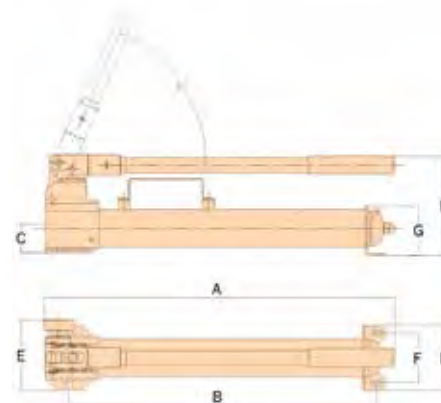

PRODUCT NO.	MODEL NO.	Speed	Usable Oil Volume	Pressure Rating		Oil Output Per Stroke		Handle Force	Oil Output Thread	Product Weight
				1st Stage	2nd Stage	1st Stage	2nd Stage			
			In ³	PSI	PSI	In ³	In ³	lb	In	lb / kg
033101	HPS55	Dual	55	360	10,000	2.038	0.201	108	3/8 - 18NPT	16.06 / 4.56
033102	HPS140	Dual	140	360	10,000	2.038	0.201	108	3/8 - 18NPT	22.22 / 10.08

HAND PUMP SELECTION CHART

PRODUCT NO.	MODEL NO.	Stage	Flow (In ³)	Capacity (Tons)							
				5	10	15	25	30	50	75	
				Required strokes for cylinder to lift 1 inch							
033101	HPS55	1st Stage	2.038	1	2	2	3				
		2nd Stage	0.201	6	12	16	26				
033102	HPS140	1st Stage	2.038	1	2	2	3	4	6	8	
		2nd Stage	0.201	6	12	16	26	31	55	81	



INDUSTRIAL RUBBER HYDRAULIC HOSES



PRODUCT NO.	MODEL NO.	Hose Material	Internal Diameter	Working Pressure	Burst Pressure	Thread	Length
			In	PSI	PSI	In	Ft
033130	HPH8206	Rubber	1/4	10,000	20,000	3/8 - NPT	6
033131	HPH8210	Rubber	1/4	10,000	20,000	3/8 - NPT	10
033132	HPH8220	Rubber	1/4	10,000	20,000	3/8 - NPT	20
033137	HPH7306	Rubber	3/8	10,000	20,000	3/8 - NPT	6
033138	HPH7310	Rubber	3/8	10,000	20,000	3/8 - NPT	10
033139	HPH7320	Rubber	3/8	10,000	20,000	3/8 - NPT	20

QUICK COUPLERS

PRODUCT NO.	MODEL NO.	Max Pressure	Type	Thread	Coupler Type
		PSI		In	
033140	QC201MF				Male / Female
033141	QC201F	10,000	High flow	3/8 - 18NPT	Female
033142	QC201M				Male

HYDRAULIC VALVES

Manual Needle Valve 033165

- Needle valve, manually controls the speed of cylinder, can be used as a shut-off valve for temporary load holding

Manual Check Valve 033160

- Manually operated check valve used to hold load with single or double acting cylinder, manually opened to allow oil to flow back to oil reserve when cylinder retracts.



033165



033160



INDUSTRIAL PRESSURE GAUGES



PRODUCT NO.	MODEL NO.	Pressure Range		Thread	Gauge Diameter
		MPa	PSI	In	In
033150	HPG2510	0 - 100	0 - 15,000	1/4 - NPT	2.5
033151	HPG4010	0 - 100	0 - 15,000	1/2 - NPT	4

GAUGE ADAPTERS

PRODUCT NO.	MODEL NO.	Female Coupler Thread	Male Coupler Thread	Gauge Thread	A	B	C	D	E	F
		In	In	In	In	In	In	In	In	In
033152	GA001	3/8 - NPT	3/8 - NPT	1/2 - NPT	2.79	1.22	1/2 - NPT	3/8 - NPT	3/8 - NPT	1.25
033153	GA002	3/8 - NPT	3/8 - NPT	1/2 - NPT	6.1	1.37	1/2 - NPT	3/8 - NPT	3/8 - NPT	1.25
033154	GA003	3/8 - NPT	3/8 - NPT	1/4 - NPT	5.23	1.88	1/4 - NPT	3/8 - NPT	3/8 - NPT	1.25
033155	GA004	3/8 - NPT	1/4 - NPT	1/2 - NPT	4.37	1.37	1/2 - NPT	1/4 - NPT	3/8 - NPT	1.25
033156	GA005	3/8 - NPT	3/8 - NPT	1/4 - NPT	5.27	1.37	1/4 - NPT	3/8 - NPT	1/4 - NPT	1.25

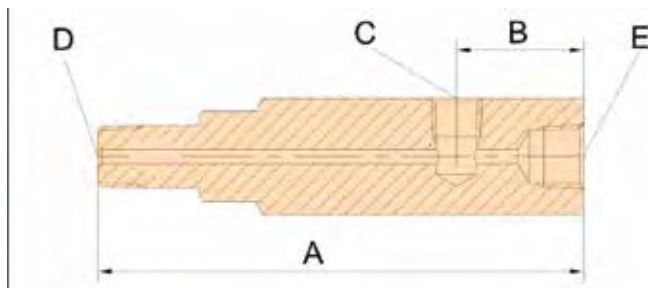

WARRANTY

ONE YEAR LIMITED WARRANTY

JET EQUIPMENT & TOOLS LTD. (JET®) makes every effort to ensure that STRONGARM branded products meet the highest quality and durability standards. All STRONGARM products are guaranteed to be free of defects in material and workmanship for a period of one year following the date of purchase. This warranty is extended to the original retail purchaser only.

If one of these products fail during its warranty period due to defective material or workmanship, it will be repaired or replaced at JET's discretion.

This warranty does not apply to any product showing signs of abuse, misuse, overloading, alteration, or improper maintenance. Normal wear and tear on moving parts or seals where applicable is specifically excluded from this warranty. To obtain repair or replacement, the defective product must be shipped, transportation charges prepaid, to the nearest authorized service depot with proof of purchase.

Repair or replacement is the exclusive remedy for defective equipment under this warranty. This Warranty is expressly in lieu of all other warranties, including the implied warranty of merchantability or any implied warranty of fitness for a particular application on this equipment.

JET shall not be liable for any consequential or incidental damages for breach of any expressed or implied warranty on this equipment.

WARNING

JACKS ARE FOR LIFTING VEHICLES ONLY. Support the vehicle with safety stands immediately after lifting.

DO NOT attempt to move the vehicle with the jack. Use only on a hard level surface.

Auxiliary / High Stands are for accessories only and are not designed or intended to support a vehicle. Transmission Jacks are for the removal, installation and transportation of transmissions and differentials. Transmission Jacks may be used with appropriate adapters manufactured specifically for the jack to handle other components, such as rear axle units and transfer cases, within the weight limitations specified. No alteration to any of the jacks or adapters shall be made. Do not overload. Do not extract or drain caustic or flammable products with any of our lubrication equipment. Only use the device for the purpose for which it has been designed. Follow safety instructions included with product for safe use.

JET reserves the right to change appearance and specifications at any time.

**SAFETY
AND
PRODUCTIVITY**

DESIGN

With features like premium stage III anodization and long battery life, our products are designed for our tough Canadian work environments

QUALITY

From Cree® SMD's to gold plated contacts, only the best materials are used in our products

STANDARDS

Our products meet stringent electrical standards so you can be confident they are safe to use

LIGHTING



DID YOU KNOW?

Many of our lighting products are IP rated for wet weather use



LED FLASHLIGHTS



- Highly efficient Cree® SMD element produces an intense ultra-bright white light
- SMD technology is more robust and produces more light than standard LED bulbs
- Up to 100,000 hours' lifetime
- Machined aluminum reflector gathers and focuses light for maximum output
- 5 Function switch cycles between 100% - 50% - 25% - SOS - flash/strobe*
- Advanced Focus System allows user to focus from spot to wide angle beam
- Aircraft grade aluminum body for durability and resistance to corrosion
- Premium Stage III anodization resists scratches and meets military specifications
- IPX-6 water resistant rating
- Drop tested to 1.5 meters
- Gold plated contacts prevent corrosion
- Tail mounted switch for tactical applications**
- Reverse polarity protection prevents damage if batteries are inserted incorrectly
- Includes batteries, lanyard, and spare o-rings



LED Penlight - 100 Lumens

849802 / JLPL-100

* 5 Function switch not available



LED Flashlight - 100 Lumens

849811 / JLFL-100



LED Flashlight - 150 Lumens

849812 / JLPL-150

PROD. NO.	MOD. NO.	Lumens @ 100%	Lumens @ 50%	Lumens @ 25%	Runtime @ 100%	Runtime @ 50%	Runtime @ 25%	Beam Distance	Length	Battery Type
849802	JLPL-100	100	-	-	5 Hours	-	-	50m	5-3/4"	2 x AAA
849811	JLFL-100	100	50	25	2 Hours	4 Hours	8 Hours	200m	4-1/2"	1 x AA
849812	JLFL-150	150	70	35	2 Hours	4 Hours	8 Hours	'200m	6-1/2"	2 x AA

BATTERIES INCLUDED WITH ALL FLASHLIGHTS



LED Flashlight - 200 Lumens

849816 / JLFL-200



LED Flashlight - 230 Lumens

849817 / JLFL-230



LED Flashlight - 500 Lumens

849818 / JLFL-500

** Barrel mounted switch



LED Flashlight - 600 Lumens with USB cable

849819 / JLFL-600U



Pouch Included



USB Outlet

PROD. NO.	MOD. NO.	Lumens @ 100%	Lumens @ 50%	Lumens @ 25%	Runtime @ 100%	Runtime @ 50%	Runtime @ 25%	Beam Distance	Length	Battery Type
849816	JLFL-200	200	100	50	3 Hours	6 Hours	12 Hours	200m	5-1/2"	3 x AAA
849817	JLFL-230	230	110	50	6 Hours	12 Hours	24 Hours	200m	7-1/4"	2 x C
849818	JLFL-500	500	300	150	3 Hours	10 Hours	20 Hours	300m	10"	2 x D
849819	JLFL-600U	600	300	150	2 Hours	3.5 Hours	7 Hours	150m	6-1/2"	USB Cable or 3 x AAA

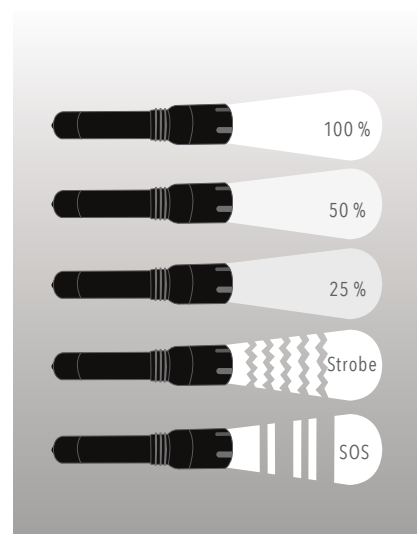
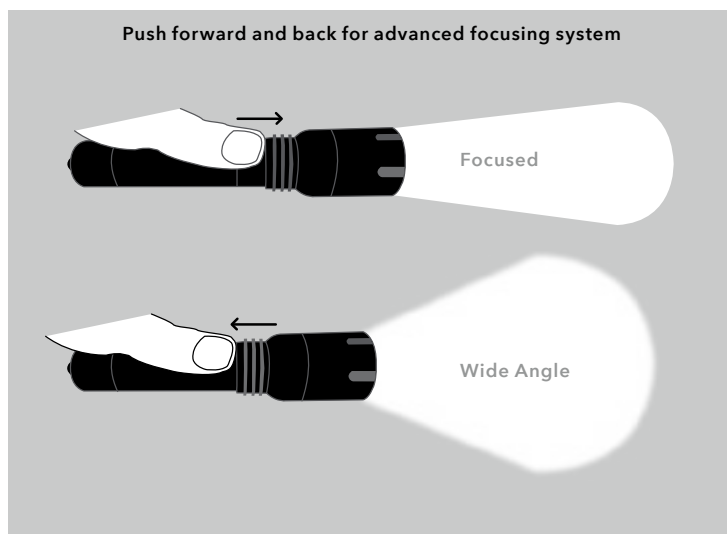

5 Function Switch



LED HEADLAMP



Battery Pack

Rear Mounted Safety Light

LED Headlamp

849821 / JLHL-220

- Highly efficient Cree® SMD element produces an intense ultra-bright white light
- SMD technology is more robust and produces more light than standard LED bulbs
- Up to 100,000 hours' lifetime
- IPX-5 water resistant rating
- Drop tested to 1.5 meters
- Front light tilts to 9 positions for easy aiming at work
- Equipped with sensor, allowing user to turn light off and on with a wave of the hand
- 5-position switch cycles between 100% with sensor, 100%, 25%, mini-lights, and SOS flash
- Separate switch at back controls rear mounted red warning light
- Fully adjustable head band can be worn with or without a hat or helmet
- Rear-mounted battery pack

PROD. NO.	MOD. NO.	Lumens	Runtime @ 100%	Beam Distance	Battery Type
849821	JLHL-220	220	6 Hours	120m	3 x AA

Front light tilts to 9 positions for easy aiming at work



Position 1 of 9 - Straight ahead

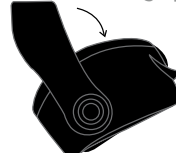

Position 9 of 9

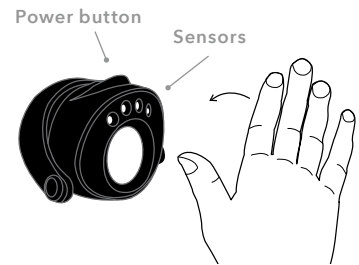

Hand wave gesture in front of sensors turns light on or off



LED Work Light - 150 Lumens

849831 / JLWL-30

- Highly efficient Surface Mounted Diodes produce 2x the light of standard LED's
- Up to 100,000 hours' lifetime
- Rechargeable Ni-Mh battery
- Tough ABS housing and polycarbonate lens for heavy duty service
- IP-44 moisture rating
- Includes top hook and magnet for suspending light above work area
- Includes AC/DC and 12 V chargers

NOTE: Replacement chargers are available

PROD. NO.	MOD. NO.	Lumens	Run Time High / Low	Charging Time	Overall Length
849831	JLWL-30	150	4/5 Hours	5 Hours	15"



849831

LED Work Light 300, 420, 600 Lumens

- Highly efficient Surface Mounted Diodes produce an intense ultra-bright white light
- SMD technology is more robust and produces 2x the light of standard LED bulbs
- Up to 100,000 hours lifetime
- Lithium-ion battery for long run times and long life
- Soft start technology illuminates SMD's gradually, protecting user from sudden bright beam
- Multiple state charge indicator changes from green to red as battery runs down
- IP-66 moisture rating allows light to be washed in water
- 1 meter drop tested
- Includes top hook for suspending light above work area
- TPR overmould handle for non-slip grip
- All models include AC/DC and 12 V chargers
- Unlimited run times when used with charger
- 2-way switch allows user to choose high or low output modes for brightest light or maximum run time

NOTE: Replacement chargers are available

PROD. NO.	MOD. NO.	Lumens	Run Time High / Low	Charging Time	Overall Length
849833	JLNL-60	300	3/6 Hours	3 Hours	15-1/2"
849837	JLWL-90	600	4/8 hours	2 Hours	22"
849835	JLWL-66	420	3/6 Hours	3 Hours	16"



849833



849835



849837

Magnetic Stand

849896 / JLWL-66

- For use with products 849835 and 849837





UNDERHOOD LED LIGHTBAR



LED Lightbar

849839 / JALB-120

- Highly efficient Surface Mounted Diodes produce an intense ultra-bright white light
- SMD technology is more robust and produces 2x the light of standard LED bulbs
- Up to 100,000 hours' lifetime
- 7.4V 4400mAH Lithium ion battery for long run times and long life
- ABS and aluminum construction for durability
- 2 operating modes illuminate 120 SMD's for maximum light or 40 SMD's for longest run time
- Foam covered hooks protect painted surfaces
- Hooks extend from 53" – 72" for mounting across vehicle hoods, inside passenger compartments, or under cabinets
- Can be used free standing for lighting work benches
- Perfect for lighting large areas without the heat of halogen or power cords that get in the way
- Foldable for storage
- For dry use only
- Includes AC/DC and 12V chargers

NOTE: Replacement chargers are available



PROD. NO.	MOD. NO.	Lumens	Run Time High/Low	Charging Time	Overall Length	Folded Length
849839	JALB-120	200	4/8 Hours	10 - 14 Hours	53 - 72"	28"

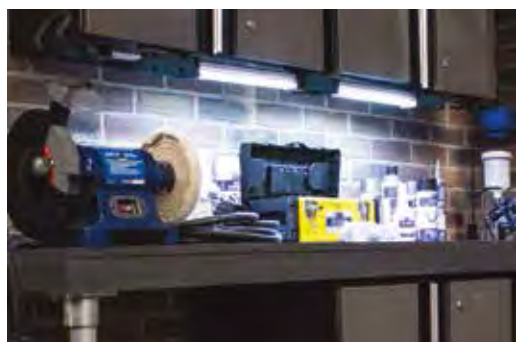
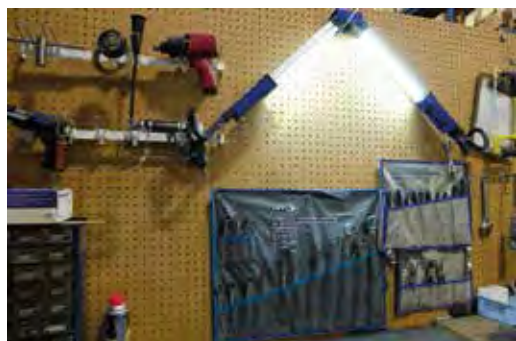

FLUORESCENT WORK LIGHTS



- 25 foot cord for improved access without using an extension
- Shatter resistant polycarbonate housing stands up to rough handling
- Rotating top hook allows user to hang light for hands free use

25 Foot 15 Watt Fluorescent Work Light **849851** / JFWL-151825

- 15 watt fluorescent bulb stays cool and lasts up to 7 times longer than incandescent bulbs
- 18/2 SJTW cord
- With 2 additional hooks for hanging light horizontally
- Ballast located at cord end to reduce weight
- For dry use only

25 Foot 13 Watt Fluorescent Work Light **849852** / JFWL-131825

- 13 watt fluorescent bulb stays cool and lasts up to 7 times longer than incandescent bulbs
- 18/2 SJTW cord
- Ballast and switch built into handle
- For dry use only

25 Foot 13 Watt Fluorescent Work Light with Magnet **849853** / JFWL-131625

- 13 watt fluorescent bulb stays cool and lasts up to 7 times longer than incandescent bulbs
- 16/3 SJTW cord
- Built-in grounded receptacle allows convenient use of power tools at work site
- Adjustable magnet mounts light to any metal surface
- Second hook for conveniently mounting light in horizontal position
- Ballast and switch built into handle
- For dry use only

LED WORK LIGHTS

LED Work Light with Magnet **849834** / JLWL-48

- Highly efficient Surface Mounted Diodes produce an intense ultra-bright white light
- SMD technology is more robust and produces 2x the light of standard LED bulbs
- Up to 100,000 hours' lifetime
- 16/3 SJTW cord
- Shatter resistant polycarbonate housing stands up to rough handling
- Built-in grounded receptacle allows convenient use of power tools at work site
- Adjustable magnet mounts light to any metal surface
- Rotating top hook allows user to hang light for hands free use
- Second hook for conveniently mounting light in horizontal position
- For dry use only



PROD. NO.	MOD. NO.	Cord Length	Cord Gauge	Volts	Amps	Max. Watts	Bulb Wattage	Overall Length
849851	JFWL-151825	25'	18/2 SJTW	120V-60Hz	.305	15W	15W	24"
849852	JFWL-131825	25'	18/2 SJTW	120V-60Hz	.350	13W	13W	12"
849853	JFWL-131625	25'	16/3 SJTW	120V-60Hz	12	1,440W	13W	13"
849834	JLWL-48	6'	16/3 SJTW	125V-60Hz	0.7	1,125W	5W	15"



849876

CORD REELS

- Reel mounts to wall or ceiling with included hardware
- Epoxy coated metal reel for compact tangle-free storage
- Cord locks at any length and rewinds with a slight tug

30 Foot Cord Reel with Fluorescent Work Light

849872 / JFCR-131630

- 16/3 SJTW cord
- 13 watt fluorescent bulb stays cool and lasts up to 7 times longer than incandescent bulbs
- 30 foot cord for improved access without using an extension
- Ballast and switch built into handle
- Shatter resistant polycarbonate light housing stands up to rough handling
- Second hook for conveniently mounting light in horizontal position
- Rotating top hook allows user to hang light for hands free use
- Adjustable magnet mounts light to any metal surface
- Built-in grounded receptacle allows convenient use of power tools at work site
- For dry use only

25 Foot Cord Reel with LED Work Light

849871 / JLCR-4825

- 16/3 SJTW cord
- Highly efficient Surface Mounted Diodes produce an intense ultra-bright white light
- SMD technology is more robust and produces 2x the light of standard LED bulbs
- Up to 100,000' hours lifetime
- Shatter resistant polycarbonate light housing stands up to rough handling
- Second hook for conveniently mounting light in horizontal position
- Rotating top hook allows user to hang light for hands free use
- Adjustable magnet mounts light to any metal surface
- Built-in grounded receptacle allows convenient use of power tools at work site
- For dry use only

30 Foot Steel Cord Reel

849875 / JSCR-1430

- 14/3 SJTW cord for indoor and outdoor use
- 3 grounded outlets with 13 Amp resettable circuit breaker provides power for up to 3 items with protection from power surges and overloads
- Cord locks at any length and rewinds with a slight tug
- 13 amps
- 1,625 watts

ABS Cord Reels

- SJTW cord for indoor and outdoor use
- Industrial grade ABS reel resists corrosion, will not dent, and is lightweight
- Reel mounts to wall or ceiling with included hardware
- Quick release allows easy transport of cord around work site
- Cord locks at any length and rewinds with a slight tug

PROD. NO.	MOD. NO.	Cord Length	Amps	Maximum Watts	Grounded Outlets	Cold Weather Rating
849876	JPCR-1450	50'	13	1,625W	3	-30°C to 60°C
849877	JPCR-1240	40'	15	1,875W	3	-30°C to 60°C

100 Foot Temporary Light String

849879 / JTLSS-14100

- Provides temporary lighting for construction sites, renovations, warehouses or anywhere extra light is needed
- 14/3 SJTW cord for indoor and outdoor use
- 10 lights spaced 10 feet apart
- Multiple strings can be connected for additional length
- Plastic cages protect light bulbs and are corrosion proof
- No tools required to change bulbs
- NEMA 15-5 plug and connector
- Connectors located no more than 1 foot from last light in string
- Power tools can be connected to end receptacle provided overall wattage of light string is not exceeded
- Suitable for use with incandescent, fluorescent, and LED light bulbs
- Maximum 150 W bulb per cage
- 13 Amps
- 1,625 watts





CORDS AND CORD ADAPTERS

- SJTOW cord for indoor and outdoor use
- Stays flexible to -50°C
- Resists most shop chemicals
- Lighted tap indicates when power is on



849866



849881



849894

Single Tap Cords

PROD. NO.	MOD. NO.	Gauge	Length	Amps	Maximum Watts
849861	JLEC-1425S	14/3	25'	15	1,875W
849862	JLEC-1450S	14/3	50'	15	1,875W
849864	JLEC-14100S	14/3	100'	15	1,875W
849866	JLEC-1225S	12/3	25'	15	1,875W
849867	JLEC-1250S	12/3	50'	15	1,875W
849869	JLEC-12100S	12/3	100'	15	1,875W

Tri-Tap Cords

- Delta style tap designed to minimize snagging on

PROD. NO.	MOD. NO.	Gauge	Length	Amps	Maximum Watts	Cold Weather Rating
849881	JLEC-1425	14/3	25'	15	1,875W	-50°C
849882	JLEC-1450	14/3	50'	15	1,875W	-50°C
849884	JLEC-14100	14/3	100'	15	1,875W	-50°C
849886	JLEC-1225	12/3	25'	15	1,875W	-50°C
849887	JLEC-1250	12/3	50'	12	1,875W	-50°C
849889	JLEC-12100	12/3	100'	15	1,875W	-50°C

Tri Tap Adapters

- Converts any single tap extension cord to a 3 outlet cord

PROD. NO.	MOD. NO.	Gauge	Length	Amps	Maximum Watts	Grounded Outlets
849893	JLTA-143	14/3	3'	15	1,875W	3
849894	JLTA-123	12/3	3'	15	1,875W	3



LED FLASHLIGHTS											
PRO. NO.	MOD. NO.	LUMENS	RUNTIME @ 50%	BEAM DISTANCE	LENGTH	WATER RESISTANCE CODE	BATTERY TYPE	BATTERIES INCLUDED	ADVANCED FOCUS SYSTEM	5-WAY SWITCH	USB CABLE
849802	JLPL-100	100	5 HRS	50M	5-3/4"	IPX6	2 X AAA	YES	YES	NO	NO
849811	JLFL-100	100	2 HRS	200M	4-1/2"	IPX6	1 X AA	YES	YES	YES	NO
849812	JLFL-150	150	2 HRS	200M	6-1/2"	IPX6	2 X AA	YES	YES	YES	NO
849816	JLFL-200	200	3 HRS	200M	7-1/4"	IPX6	2 X C	YES	YES	YES	NO
849817	JLFL-230	230	6 HRS	200M	5-1/2"	IPX6	3 X AAA	YES	YES	YES	NO
849818	JLFL-500	500	3 HRS	300M	10"	IPX6	2 X D	YES	YES	YES	NO
849819	JLFL-600U	600	2 HRS	150M	6-1/2"	IPX6	3 X AAA	NO	YES	YES	YES

HEADLAMP											
849821	JLHL-220	220	6 HRS	120M	-	IPX5	3AA	YES	NO	YES	NO

RECHARGEABLE LED WORKLIGHTS										
PRO. NO.	MOD. NO.	LUMENS	RUNTIME	SMD LEDS	LENGTH	WATER RESISTANCE CODE	TOP HOOK MOUNT	UNDER HOOD	CHARGE TIME	
849831	JLWL-30	150	4/5 HRS	30	17-1/2"	IP44	YES	-	5 - 7 HRS	
849833	JLNL-60	300/150	3/6 HRS	60	15-1/2"	IP67	YES	-	3 HRS	
849835	JLWL-66	420/230	3/6 HRS	66	16"	IP67	YES	-	3 HRS	
849837	JLWL-90	600/350	4/8 HRS	90	21-1/2"	IP67	YES	-	2 HRS	

LED LIGHTBAR										
849839	JALB-120	1200/400	4/8 HRS	120	53-72"	IP20	NO	YES	10 - 14 HRS	

WORK LIGHTS										
PRO. NO.	MOD. NO.	FLUORESCENT WATTS	STYLE	POWER OUTLET	LENGTH	WATER RESISTANCE	TOP HOOK	MAGNET	CORD LENGTH	
849851	JFWL-151825	15	STRAIGHT TUBE	NO	20"	DRY USE ONLY	YES	NO	25'	
849852	JFWL-131825	13	ANGLE	NO	12"	DRY USE ONLY	YES	NO	25'	
849853	JFWL-151625	13	ANGLE	YES	13"	DRY USE ONLY	YES	YES	25'	
849872	JFCR-131630	13	ANGLE	YES	13"	DRY USE ONLY	YES	YES	25'	

LED WORK LIGHTS										
PRO. NO.	MOD. NO.	LUMENS	LEDS	STYLE	POWER OUTLET	LENGTH	WATER RESISTANCE	TOP HOOK	MAGNET	CORD LENGTH
849834	JLWL-20	320	20	ANGLE	YES	15"	DRY USE ONLY	YES	YES	6'
849871	JLCR-2025	320	20	ANGLE	YES	12"	DRY USE ONLY	YES	YES	25'

CORD REELS										
PRO. NO.	MOD. NO.	CONSTRUCTION	GROUNDING OUTLET	CORD LENGTH	VOLTS	AMPS	MAXIMUM WATTS			
849875	JSCR-1430	STEEL	3	30'	125V - 60HZ	13	1,625			
849876	JPCR-1450	ABS	3	50'	125V - 60HZ	15	1,625			
849877	JPCR-1240	ABS	3	40'	125V - 60HZ	15	1,875			

LIGHT STRING										
PRO. NO.	MOD. NO.	LIGHTS PER STRING	CORD LENGTH	VOLTS	MAXIMUM WATTS	BULB WATTAGE				
849879	JTLS-14100	10	100'	125V - 60HZ	1,625	150 W MAX.				

WARRANTY

WARRANTY POLICY

All STARTECH lighting products are covered by our Lifetime Warranty against defects in materials or workmanship for the useful life of the tool. Multiple element lights will be replaced if a significant number of elements fail, compromising overall output. Specifically excluded from warranty are alkaline and rechargeable batteries, o-ring seals, lanyards and pouches.



ITC

SAFETY AND PRODUCTIVITY

STANDARDS

Our tools meet or exceed international design standards to ensure you get the job done right the first time

DESIGN

With features like ergonomic handles to cushioned grips, build value into our designs

QUALITY

From chrome vanadium steel to polypropylene hose reels, only the best materials are used in our tools



DID YOU KNOW?

ITC Tools is a quality line of products aimed at budget conscious professional workers.

676

Hand Tools 678

Chrome Socket Sets.....	678-680	Hex Key Wrench Sets.....	694
Chrome Sockets SAE - Open stock.....	681	Punch and Chisel Sets.....	695
Socket Accessories.....	681	Pry and Wrecking Bars.....	696
Chrome Sockets Metric - Open Stock.....	682	Striking Tools.....	697
Impact Socket Sets.....	683	Miscellaneous Products.....	698
Combination Wrench Sets.....	684-686	Measuring Tools.....	699
Wrenches - Open Stock.....	687	Screw Extractor Sets.....	699
Torque Wrenches.....	688	Hand Saws.....	700
Pipe Wrenches.....	688	Files.....	700
Adjustable Wrenches.....	689	C-Clamps.....	700
Tin Snips.....	689	Vises.....	700
Bolt Cutters.....	690	Magnetic Tools.....	701
Utility Knives.....	690	Tie Downs.....	702
Locking Pliers.....	691	Tap and Die Sets.....	703
Pliers.....	691	Cable Puller.....	703
Screwdrivers.....	692-693		

Automotive Products 704-705

Air Tools 706

Impact Wrenches.....	706	Miscellaneous Air Tools.....	708
Die Grinders.....	707	Hose Reels and Hoses.....	709

Shop Equipment 710

Compressors.....	710	Lifting Equipment.....	711
Creepers.....	710	Power Tools.....	711-712
Bench Grinders.....	710	Warranty Policy.....	714

ICON LEGEND

6 Point.....		Slotted Screwdriver.....		Warning Note.....	
12 Point.....		Phillips Screwdriver.....		New.....	
Chrome Vanadium.....		Square Screwdriver.....			
Use Eye Protection.....		Torx® Screwdriver.....			





40 PC 1/4" Drive SAE / Metric Socket Set - 6 pt

020113 / ISK-1440SM

- Chrome Vanadium steel
- 5-1/2" quick release ratchet
- 2" and 6" extensions
- Popular 6 point sockets
- Features SAE and Metric regular and deep sockets
- SAE Shallow and Deep: 3/16, 7/32, 1/4, 9/32, 5/16, 11/32, 3/8, 7/16, 1/2"
- Metric Shallow and Deep: 4, 5, 6, 7, 8, 9, 10, 11, 12 mm

6 CrV



20 PC 3/8" Drive SAE Socket Set - 6 pt

020123 / ISK-3820S

- Chrome Vanadium steel
- 8" quick release ratchet
- 8-1/2" flex handle
- 3" extension
- Universal joint
- Popular 6 point sockets
- Features regular and deep sockets
- SAE Shallow: 3/8, 7/16, 1/2, 9/16, 5/8, 11/16, 3/4"
- SAE Deep: 3/8, 7/16, 1/2, 9/16, 5/8, 11/16, 3/4, 13/16"

6 CrV



20 PC 3/8" Drive Metric Socket Set - 6pt

020124 / ISK-3820M

- Chrome Vanadium steel
- 8" quick release ratchet
- 8-1/2" flex handle
- 3" extension
- Universal joint
- Popular 6 point sockets
- Features regular and deep sockets
- Metric Shallow: 10, 12, 13, 15, 17, 18, 19, 22 mm
- Metric Deep: 10, 12, 13, 15, 17, 18, 19 mm

6 CrV

WARNING: Do not use chrome sockets on impact wrenches

49 PC 3/8" Drive SAE / Metric Socket Set - 6 pt

020125 / ISK-3849SM

- Chrome Vanadium steel
- 8" quick release ratchet
- 3" and 6" extensions
- Universal joint
- Popular 6 point sockets
- Features SAE and Metric, regular and deep sockets
- SAE Shallow and Deep: 3/8, 7/16, 1/2, 9/16, 5/8, 11/16, 3/4, 13/16, 7/8"
- Metric Shallow: 6, 7, 8, 9, 10, 11, 12, 13, 14, 15, 16, 17, 18, 19 mm
- Metric Deep: 8, 9, 10, 11, 12, 13, 14, 15, 16, 17, 18, 19 mm

6 CrV



20 PC 1/2" Drive SAE Socket Set - 6 pt

020133 / ISK-1220S

- Chrome Vanadium steel
- 10" quick release ratchet
- 17" flex handle
- 5" and 10" extensions
- Universal joint
- Popular 6 point sockets
- SAE Shallow: 3/8, 7/16, 1/2, 9/16, 5/8, 11/16, 3/4, 13/16, 7/8, 15/16, 1, 1-1/16, 1-1/8, 1-1/4"

6 CrV



24 PC 1/2" Drive Metric Socket Set - 6pt

020134 / ISK-1224M

- Chrome Vanadium steel
- 10" quick release ratchet
- 17" flex handle
- 5" and 10" extensions
- Universal joint
- Popular 6 point sockets
- Metric Shallow: 10, 11, 12, 13, 14, 15, 16, 17, 18, 19, 20, 21, 22, 23, 24, 27, 30, 32 mm

6 CrV



WARNING: Do not use chrome sockets on impact wrenches



020304

6 12 CrV

Chrome Vanadium steel sockets and drive tools in one convenient high impact blow mould case - ready for any job!

CHROME SOCKET SETS

49 PC 1/2" Drive SAE / Metric Socket Set - 6 pt

020135 / ISK-1249SM

- Chrome Vanadium steel
- 10" quick release ratchet
- 15" flex handle
- 5" extension
- Universal joint
- Popular 6 point sockets
- Features SAE and Metric regular and deep sockets
- SAE Shallow: 3/8, 7/16, 1/2, 9/16, 5/8, 11/16, 3/4, 13/16, 7/8, 15/16, 1, 1-1/16, 1-1/8, 1-1/4"
- SAE Deep: 9/16, 5/8, 11/16, 3/4, 13/16, 7/8"
- Metric Shallow: 10, 11, 12, 13, 14, 15, 16, 17, 18, 19, 20, 21, 22, 23, 24, 27, 30, 32 mm
- Metric Deep: 13, 15, 17, 18, 19, 22 mm

6 CrV

21 PC 3/4" Drive SAE Socket Set - 12 pt

020141 / ISK-3421

- Chrome Vanadium steel
- 20" round head ratchet
- 18" sliding T-handle
- 4" and 8" extensions
- Popular 12 point sockets
- SAE Shallow: 3/4, 7/8, 15/16, 1, 1-1/16, 1-1/8, 1-3/16, 1-1/4, 1-5/16, 1-3/8, 1-7/16, 1-1/2, 1-5/8, 1-3/4, 1-7/8, 2"

12 CrV

200 PC Mechanic's Tool Set

020304 / IMTK-200

- 1/4", 3/8", and 1/2" drive SAE and Metric sockets in 6 point, 12 point, regular, and deep styles for maximum versatility
- Quick release 36 tooth ratchets with heavy duty pawls exceed ANSI standards for torque and tolerance
- Combination wrenches, hex keys, nut setters, and screwdriver bits

CONTAINS:

- 1 PC 1/4" Dr. Quick Release Ratchet Handle and 1 PC 1/4" Dr. x 3" Extension Bar
- 11 PC 1/4" Dr. Sockets (6pt, SAE) 5/32", 3/16", 7/32", 1/4", 9/32", 5/16", 11/32", 3/8", 7/16", 1/2", 9/16"
- 12 PC 1/4" Dr. Sockets (6pt, Metric) 4, 5, 5.5, 6, 7, 8, 9, 10, 11, 12, 13, 14 mm
- 7 PC 1/4" Dr. Deep Sockets (6pt, SAE) 3/16", 1/4", 9/32", 5/16", 3/8", 7/16", 1/2"
- 7 PC 1/4" Dr. Deep Sockets (6pt, Metric) 7, 8, 9, 10, 11, 12, 13 mm
- 1 PC 3/8" Dr. Quick Release Ratchet Handle
- 1 PC 3/8" Dr. x 3" Extension Bar and 1 PC 3/8" Dr. x 6" Extension Bar
- 1 PC 3/8" Dr. x 5/8" Spark Plug Socket and 1 PC 3/8" Dr. x 13/16" Spark Plug Socket
- 9 PC 3/8" Dr. Sockets (6pt, SAE) 1/4", 5/16", 3/8", 7/16", 1/2", 9/16", 5/8", 11/16", 3/4"
- 13 PC 3/8" Dr. Sockets (6pt, Metric) 6, 7, 8, 9, 10, 11, 12, 13, 14, 15, 16, 17, 19 mm
- 9 PC 3/8" Dr. Sockets (12pt, SAE) 5/16", 3/8", 7/16", 1/2", 9/16", 5/8", 11/16", 3/4", 13/16"
- 10 PC 3/8" Dr. Sockets (12pt, Metric) 9, 10, 11, 12, 13, 14, 15, 16, 17, 18 mm
- 7 PC 3/8" Dr. Deep Sockets (6pt, SAE) 3/8", 7/16", 1/2", 9/16", 5/8", 11/16", 3/4"
- 7 PC 3/8" Dr. Deep Sockets (6pt, Metric) 9, 10, 12, 13, 14, 15, 17 mm
- 1 PC 1/2" Dr. Quick Release Ratchet Handle
- 6 PC 1/2" Dr. Sockets (12pt, SAE) 7/16", 1/2", 9/16", 5/8", 11/16", 3/4"
- 6 PC 1/2" Dr. Sockets (12pt, Metric) 14, 15, 16, 17, 18, 19 mm
- 16 PC Combination Wrench Set SAE: 1/4", 5/16", 3/8", 7/16", 1/2", 9/16", 5/8", 3/4" Metric: 9, 10, 11, 12, 13, 14, 15, 17 mm
- 1 PC 1/4" Bit Drive
- 24 PC Screwdriver Bits Slotted: 1/8", 5/32", 3/16", 1/4", 1/4", 1/4" Phillips: #0, #1, #2, #2, #3 Torx®: T10, T15, T20, T25, T30, T40 Hex: 1/8", 5/32", 3/16", 7/32", 1/4", 9/32"
- 12 PC Nut Driver Bits SAE: 1/4", 9/32", 5/16", 11/32", 3/8", 7/16" Metric: 5, 6, 7, 8, 10, 11 mm
- 22 PC Short Arm Hex Key Wrench Set SAE: 0.05", 1/16", 5/64", 3/32", 7/64", 1/8", 9/64", 5/32", 3/16", 7/32", 1/4" Metric: 1.27, 1.5, 2, 2.5, 3, 3.5, 4, 4.5, 5, 5.5, 6 mm
- 12 PC Long Arm Hex Key Wrench Set SAE: 5/64", 3/32", 1/8", 5/32", 3/16", 1/4" Metric: 2, 2.5, 3, 4, 5, 6 mm

Drive	1/4"	1/4"	3/8"	3/8"	1/2"	1/2"
Size SAE	Regular 6PT	Deep 6PT	Regular 6PT	Deep 6PT	Regular 6PT	Deep 6PT
3/16"	025006	025056				
7/32"	025007	025057				
1/4"	025008	025058				
9/32"	025009	025059				
5/16"	025010	025060				
11/32"	025011	025061				
3/8"	025012	025062	025212	025262	025412	
7/16"	025014	025064	025214	025264	025414	025464
1/2"	025016	025066	025216	025266	025416	025466
9/16"			025218	025268	025418	025468
5/8"			025220	025270	025420	025470
11/16"			025222	025272	025422	025472
3/4"			025224	025274	025424	025474
13/16"			025226	025276	025426	025476
7/8"			025228	025278	025428	025478
15/16"					025430	025480
1"					025432	025482
1-1/16"					025434	025484
1-1/8"					025436	025486
1-1/4"					025440	025490

SOCKET ACCESSORIES

PROD. NO.	DESCRIPTION	PROD. NO.	DESCRIPTION
025190	1/4" DR 2" EXTENSION	025392	3/8" DR 8.5" FLEX HANDLE
025191	1/4" DR 6" EXTENSION	025393	3/8" DR UNIVERSAL JOINT
025193	1/4" DR UNIVERSAL JOINT	025590	1/2" DR 5" EXTENSION
		025591	1/2" DR 10" EXTENSION
025390	3/8" DR 3" EXTENSION	025592	1/2" DR 15" FLEX HANDLE
025391	3/8" DR 6" EXTENSION	025594	1/2" DR UNIVERSAL JOINT

Oval Head Ratchet Wrenches

- All components forged from superior quality Chrome Vanadium steel
- Push button quick release holds socket securely
- Convenient easy-use reversion switch
- Meets or exceeds ANSI specifications

NEW

PROD. NO.	MOD. NO.	Drive	Length	Teeth	Quick Release
025195	IRH-14	1/4"	6"	36	Yes
025395	IRH-38	3/8"	8"	36	Yes
025595	IRH-12	1/2"	10"	36	Yes



025195



025395



025595



WARNING: Do not use chrome sockets on impact wrenches



CHROME SOCKETS METRIC - OPEN STOCK

Drive	1/4"		3/8"		1/2"	
	Regular 6PT	Deep 6PT	Regular 6PT	Deep 6PT	Regular 6PT	Deep 6PT
4 mm	025104	025154				
5 mm	025105	025155				
6 mm	025106	025156	025306			
7 mm	025107	025157	025307			
8 mm	025108	025158	025308	025358		
9 mm	025109	025159	025309	025359		
10 mm	025110	025160	025310	025360	025510	025560
11 mm	025111	025161	025311	025361	025511	
12 mm	025112	025162	025312	025362	025512	025562
13 mm			025313	025363	025513	025563
14 mm			025314	025364	025514	025564
15 mm			025315	025365	025515	025565
16 mm			025316	025366	025516	025566
17 mm			025317	025367	025517	025567
18 mm			025318	025368	025518	025568
19 mm			025319	025369	025519	025569
20 mm			025320		025520	025570
21 mm			025321		025521	025571
22 mm			025322		025522	025572
23 mm					025523	025573
24 mm					025524	025574
27 mm					025527	
30 mm					025530	
32 mm					025532	



IMPACT SOCKET SETS



- Chrome Vanadium steel sockets specially hardened for use on power driven tools
- Torque-Drive® sockets apply torque to flats of fasteners to prevent corner rounding and increase torque
- Electroplate finish resists corrosion
- Large easy to read size markings
- Complete with handy blow mould storage case

13 PC 1/2" Drive SAE Impact Socket Sets

PROD. NO.	MOD. NO.	Length	Size Range
020722	IPS-1312	Regular	7/16, 1/2, 9/16, 5/8, 11/16, 3/4, 13/16, 15/16, 7/8, 1, 1-1/16, 1-1/8, 1-1/4"
020727	IPS-1312D	Deep	7/16, 1/2, 9/16, 5/8, 11/16, 3/4, 13/16, 15/16, 7/8, 1, 1-1/16, 1-1/8, 1-1/4"



020722



020727

14PC 1/2" Drive Metric Impact Socket Sets

- Chrome Vanadium steel sockets specially hardened for use on power driven tools
- Torque-Drive® sockets apply torque to flats of fasteners to prevent corner rounding and increase torque
- Electroplate finish resists corrosion
- Large easy-to-read size markings
- Complete with handy blow mould storage case

PROD. NO.	MOD. NO.	Length	Size Range
020732	IPS-1214M	Regular	10, 11, 12, 13, 14, 15, 16, 17, 18, 19, 21, 22, 26, 27 mm
020737	IPS-1214DM	Deep	10, 11, 12, 13, 14, 15, 16, 17, 18, 19, 21, 22, 26, 27 mm



020732



020737



Standard



Deep





COMBINATION WRENCH SETS

16 PC SAE Combination Wrench Set

020215 / ICW-16

- Drop forged Chrome Vanadium steel
- Raised panel style
- Fabric pouch
- SAE: 1/4, 5/16, 3/8, 7/16, 1/2, 9/16, 5/8, 11/16, 3/4, 13/16, 7/8, 15/16, 1, 1-1/16, 1-1/8, 1-1/4"

CrV



16 PC Metric Combination Wrench Set

020216 / ICW-16M

- Drop forged Chrome Vanadium steel
- Raised panel style
- Fabric pouch
- Metric: 6, 8, 9, 10, 11, 12, 13, 15, 17, 18, 19, 21, 22, 24, 30, 32 mm

CrV



22 PC SAE / Metric Combination Wrench Set

020217 / ICW-22SM

- Drop forged Chrome Vanadium steel
- Raised panel
- Meets ANSI specifications
- Convenient plastic storage rack
- SAE: 1/4, 5/16, 3/8, 7/16, 1/2, 9/16, 5/8, 11/16, 3/4, 13/16, 7/8"
- Metric: 8, 9, 10, 11, 12, 13, 14, 15, 17, 18, 19 mm

CrV



10 PC Jumbo SAE Combination Wrench Set

020202 / ICWJ-10S

- Drop forged Chrome Vanadium steel
- Heat treated for professional use
- Raised panel for increased strength
- Chrome plated for corrosion resistance
- Complete with terylene roll pouch
- SAE: 1-5/16, 1-3/8, 1-7/16, 1-1/2, 1-5/8, 1-11/16, 1-3/4, 1-13/16, 1-7/8, 2"



10 PC Jumbo Metric Combination Wrench Set

020203 / ICWJ-10M

- Drop forged Chrome Vanadium steel
- Heat treated for professional use
- Raised panel for increased strength
- Chrome plated for corrosion resistance
- Complete with terylene roll pouch
- Metric: 33, 35, 36, 38, 41, 43, 44, 46, 48, 50 mm



14 PC SAE Polished Combination Wrench Set

020210 / ICW-14PS

- Drop forged heat treated Chrome Vanadium steel
- Precision machined open and box ends
- Box ends feature anti-rounding design to prevent fastener damage
- Nickel Chrome finish resists corrosion
- Meets ANSI standards
- Includes roll up pouch
- SAE: 3/8, 7/16, 1/2, 9/16, 5/8, 11/16, 3/4, 13/16, 7/8, 15/16, 1, 1-1/16, 1-1/8, 1-1/4"



14 PC Metric Polished Combination Wrench Set

020211 / ICW-14PM

- Drop Forged heat treated Chrome Vanadium steel
- Precision machined open and box ends
- Box ends feature anti-rounding design to prevent fastener damage
- Nickel Chrome finish resists corrosion
- Meets ANSI standards
- Includes roll up pouch
- Metric: 10, 11, 13, 14, 15, 16, 17, 18, 19, 21, 22, 24, 27, 32 mm





11 PC Fully Polished SAE Combination Wrench Set

020207 / CWP-11S

- Drop forged Chrome Vanadium steel
- Full mirror polish finish
- Meets ANSI specifications
- Convenient plastic storage rack
- SAE: 1/4, 5/16, 3/8, 7/16, 1/2, 9/16, 5/8, 11/16, 3/4, 13/16, 7/8"

CrV



11 PC Fully Polished Metric Combination Wrench Set

020208 / ICWP-11M

- Drop forged Chrome Vanadium steel
- Full mirror polish finish
- Meets ANSI specifications
- Convenient plastic storage rack
- Metric: 8, 9, 10, 11, 12, 13, 14, 15, 17, 18, 19 mm

CrV



22 PC Fully Polished SAE / Metric Combination Wrench Set

020219 / ICWP-22SM

- Drop forged Chrome Vanadium steel
- Full mirror polish finish
- Meets ANSI specifications
- Convenient plastic storage rack
- SAE: 1/4, 5/16, 3/8, 7/16, 1/2, 9/16, 5/8, 11/16, 3/4, 13/16, 7/8"
- Metric: 8, 9, 10, 11, 12, 13, 14, 15, 17, 18, 19 mm

CrV



14 PC SAE Angle Wrench Set - 60° & 15°

020222 / IACW-14

- Drop forged Chrome Vanadium steel
- Fully polished mirror finish
- Vinyl pouch
- SAE: 3/8, 7/16, 1/2, 9/16, 5/8, 11/16, 3/4, 13/16, 7/8, 15/16, 1, 1-1/16, 1-1/8, 1-1/4"

CrV

WRENCHES - OPEN STOCK



- Industrial quality drop forged Chrome Vanadium steel
- Heat treated for professional use
- Raised panel for increased strength
- Chrome plated for corrosion resistance

Size - SAE	Combination
1/4"	022201
5/16"	022202
3/8"	022203
7/16"	022204
1/2"	022205
9/16"	022206
5/8"	022207
11/16"	022208
3/4"	022209
13/16"	022210
7/8"	022211
15/16"	022212
1"	022213
1-1/16"	022214
1-1/8"	022215
1-1/4"	022217
1-5/16"	022218
1-3/8"	022219
1-7/16"	022220
1-1/2"	022221
1-5/8"	022223
1-11/16"	022224
1-3/4"	022225
1-13/16"	022226
1-7/8"	022227
2"	022229
2-1/8"	022231
2-1/4"	022233
2-3/8"	022235
2-1/2"	022237

Size - Metric	Combination
6 mm	022251
7 mm	022252
8 mm	022253
9 mm	022254
10 mm	022255
11 mm	022256
12 mm	022257
13 mm	022258
14 mm	022259
15 mm	022260
17 mm	022262
18 mm	022263
19 mm	022264
21 mm	022266
22 mm	022267
24 mm	022269
26 mm	022271
27 mm	022272
30 mm	022275
32 mm	022277
33 mm	022278
35 mm	022280
36 mm	022281
38 mm	022283
41 mm	022286
43 mm	022288
44 mm	022289
46 mm	022291
48 mm	022293
50 mm	022295





TORQUE WRENCHES

3/8" Drive Torque Wrench

021801 / ITW-2060

- Click type
- Knurled handle
- Accurate to +/- 4%
- Lock-nut to lock handle
- Includes blow mould case



1/2" Drive Torque Wrench

021811 / ITW-2063

- Click type
- Knurled handle
- Accurate to +/- 4%
- Lock-nut to lock handle
- Includes 1/2" F - 3/8" M adapter and one 1/2" x 5" extension
- Adjustable from 10-150 ft/lb
- Includes blow mould case

PIPE WRENCHES

Steel Pipe Wrenches

- Forged carbon steel hook jaw
- Rockwell hardness HRC 47-52



020402

PROD. NO.	MOD. NO.	Description	Capacity
020402	IPW-10	10"	1-1/2"
020404	IPW-14	14"	2"
020405	IPW-18	18"	2-1/2"
020406	IPW-24	24"	3"
020407	IPW-36	36"	5"

Aluminum Pipe Wrenches

- Forged carbon steel hook jaw
- Rockwell hardness HRC 47-52



020415

PROD. NO.	MOD. NO.	Description	Capacity
020415	IPW-18A	18"	2-1/2"
020416	IPW-24A	24"	3"
020417	IPW-36A	36"	5

ADJUSTABLE WRENCHES



3 PC Adjustable Wrench Set

020236 / IAW-3S

- Drop forged alloy steel
- Heat-treated for durability
- Includes: 8, 10, and 12"

Adjustable wrenches - Open Stock

PROD. NO.	MOD. NO.	Description
020312	IAW-8	8"
020313	IAW-10	10"
020314	IAW-12	12"



TIN SNIPS

3 PC Aviation / Tin Snips Set

020802 / IAS-3S

- Hardened alloy steel blades
- Serrated blades prevent material from slipping out of jaws
- Colour-coded soft grip handles for superior grip and user comfort
- Contains 1 each: Left cut, right cut, straight cut

Snips - Open Stock

PROD. NO.	MOD. NO.	Description	Colour
020803	IAS-1R	Right Cut Aviation / Tin Snips	Green
020804	IAS-1S	Straight Cut Aviation / Tin Snips	Yellow
020805	IAS-1L	Left Cut Aviation / Tin Snips	Red





BOLT CUTTERS

Bolt Cutters

- Blades hardened to Rockwell HRC55-60

PROD. NO.	MOD. NO.	Description	Capacity
020504	IBC-18	18" Bolt Cutter	1/4"
020505	IBC-24	24" Bolt Cutter	5/16"
020506	IBC-36	36" Bolt Cutter	15/32"

Replacement Cutter Heads

PROD. NO.	Description
020514	18" Bolt Cutter Replacement Head
020515	24" Bolt Cutter Replacement Head
020516	36" Bolt Cutter Replacement Head



UTILITY KNIVES

6-1/2" Snap Blade Knife 027021 / ISBK-18

- Tough ABS construction
- SK5 steel blade stays sharp longer
- Blades snap off for new cutting edge
- Uses 18mm blades

6-1/2" Auto-Lock Snap Blade Knife 027022 / ISBK-18A

- Tough ABS construction with steel blade support
- Includes 5 replacement blades
- Easy slide mechanism automatically locks blade at desired length
- SK5 steel blade stays sharp longer
- Blades snap off for new cutting edge
- Uses 18mm blades

18mm Snap Blades 027018 / UKB-10

- Blades snap off for new cutting edge
- Convenient plastic case keeps blades safe and dry



NEW



NEW



NEW

3 PC Locking Pliers Set

020606 / ILPS-3C

- Tough alloy steel construction
- Comfortable rubber handle grips
- All models complete with wire cutter
- Includes: 6" Long nose pliers
7, 10" Curved jaw pliers



5 PC Locking Pliers Set

020608 / ILPS-5C

- Tough alloy steel construction
- Comfortable rubber handle grips
- All models complete with wire cutter
- Includes: 6, 9" Long nose pliers
5, 7, 10" Curved jaw pliers



PLIERS

5 PC Pliers Set

020604 / IPL-5S

- Drop forged alloy steel
- Cushion-grip handles for comfort
- Includes: 8" Lineman's pliers
8" Long nose pliers
8" Diagonal cutters
8" Slip joint pliers
10" Groove joint pliers



Pliers - Open Stock

- Drop forged alloy steel
- Cushion-grip handles for comfort

PROD. NO.	MOD. NO.	Description
020626	ICP-200	8" Lineman's Pliers
020627	IRP-200	8" Long Nose Pliers
020628	INP-200	8" Diagonal Cutters
020630	ISJ-200	8" Slip Joint Pliers
020629	IGJ-250	10" Groove Joint Pliers
020631	IGJ-300	12" Groove Joint Pliers



020626 020627 020628 020630



020629 020631



SCREWDRIVERS

15 PC Multi-bit Screwdriver Set

020921 / ISDM-15

- Includes 13 x 2-1/2" bits
- Bits conveniently stored in handle
- Includes:
 - Phillips: #0, #1, #2, #3
 - Square: #0, #1, #2, #3
 - Slotted: #0, #1, #2, #3
 - TORX®: T25, T20
 - Awl point
 - Holster

14 PC ABS Handle Screwdriver Set

020911 / ISD-14

- Fully hardened Chrome Vanadium shafts
- Magnetic tips conveniently hold screws on tip in any position
- Ergonomic handle shape allows application of extra torque
- Includes:
 - Phillips: #1 x 3", #2 x 1-1/2", #2 x 4"
 - Square: #1 x 4", #2 x 4", #3 x 4"
 - Slotted: 3/16" x 3", 1/4" x 4", 3/8" x 8", 1/4" x 1-1/2", 5/16" x 6"
 - TORX®: T15 x 4", T20 x 4", T25 x 4"

CrV

9 PC Ergonomic Screwdriver Set

020906 / IESD-9S

- Fully hardened Chrome Vanadium shafts
- Magnetic tips conveniently hold screws on tip in any position
- Double injected handles provide superior grip and user comfort
- Ergonomic handle shape allows application of extra torque
- Includes:
 - Slotted: 1/8" x 3", 3/16" x 4", 5/16" x 8"
 - Phillips: #1 x 3", #2 x 4", #2 x 6"
 - Square: #1 x 4", #2 x 4", #3 x 6"

CrV

14 PC Ergonomic Screwdriver Set

020907 / IESD-14S

- Fully hardened Chrome Vanadium shafts
- Magnetic tips conveniently hold screws on tip in any position
- Double injected handles provide superior grip and end user comfort
- Ergonomic handle shape allows application of extra torque
- Includes:
 - Slotted: 1/8" x 3", 5/32" x 3", 3/16" x 4", 1/4" x 6", 5/16" x 8"
 - Phillips: #1 x 3", #2 x 4", #3 x 6", #3 x 8"
 - Square: #1 x 4", #2 x 4", #3 x 6"
 - TORX®: T15 x 4", T20 x 4"

CrV

Ergonomic Screwdrivers - Open Stock

- Fully hardened Chrome Vanadium shafts
- Magnetic tips conveniently hold screws on tip in any position
- Double injected handles provide superior grip and user comfort
- Ergonomic handle shape allows application of extra torque

PROD. NO.	MOD. NO.	Description	Type	
021002	ISDS-3N	1/8" x 3"	Slotted Ergonomic Handle Screwdriver	⊖
021003	ISDS-3	5/32" x 3"	Slotted Ergonomic Handle Screwdriver	⊖
021005	ISDS-4	3/16" x 4"	Slotted Ergonomic Handle Screwdriver	⊖
021007	ISDS-6	1/4" x 6"	Slotted Ergonomic Handle Screwdriver	⊖
021009	ISDS-8	5/16" x 8"	Slotted Ergonomic Handle Screwdriver	⊖
021012	ISDP-1	#1 x 3"	Phillips Ergonomic Handle Screwdriver	⊕
021014	ISDP-2	#2 x 4"	Phillips Ergonomic Handle Screwdriver	⊕
021019	ISDP-3	#3 x 6"	Phillips Ergonomic Handle Screwdriver	⊕
021023	ISDR-1	#1 x 4"	Square Ergonomic Handle Screwdriver	⊞
021024	ISDR-2	#2 x 4"	Square Ergonomic Handle Screwdriver	⊞
021027	ISDR-3	#3 x 6"	Square Ergonomic Handle Screwdriver	⊞
021032	ISDT-15	T-15	Torx Ergonomic Handle Screwdriver	⊛
021033	ISDT-20	T-20	Torx Ergonomic Handle Screwdriver	⊛





020513



020514



HEX KEY WRENCH SETS

7 PC SAE Ball Nose Hex Key Set

021513 / IHKB-7S

- Chrome Vanadium
- Ball nose design allows engagement of fastener at up to 25° angle
- Convenient plastic holder
- SAE: 1/8, 5/32, 3/16, 7/32, 1/4, 5/16, 3/8"

CrV

7 PC Metric Ball Nose Hex Key Set

021514 / IHKB-7M

- Chrome Vanadium
- Ball nose design allows engagement of fastener at up to 25° angle
- Convenient plastic holder
- Metric: 2.5, 3, 4, 5, 6, 8, 10 mm

CrV

14 PC SAE / Metric Ball Nose Hex Key Set

021515 / IHKB-14SM

- Chrome Vanadium
- Ball nose design allows engagement of fastener at up to 25° angle
- Convenient plastic holder
- Combines SAE and metric sets for maximum range

CrV

10 PC SAE T-Handle Hex Key Set

021502 / ILHK-10

- Chrome Vanadium steel for strength
- Dual material handles provide comfort and sure grip
- Metal storage rack can be permanently mounted
- SAE: 3/32, 7/64, 1/8, 9/64, 5/32, 3/16, 7/32, 1/4, 5/16, 3/8"

CrV

10 PC Metric T-Handle Hex Key Set

021507 / ILHK-10M

- Chrome Vanadium steel for strength
- Dual material handles provide comfort and sure grip
- Metal storage rack can be permanently mounted
- Metric: 2, 2.5, 3, 4, 4.5, 5, 5.5, 6, 8, 10 mm

CrV

6 PC Pin and Centre Punch Set

023502 / IPC-6

- Dual heat treated Chrome Vanadium steel
- 5 Pin Punches: 3/32" x 4-1/4", 1/8" x 4-3/4", 5/32" x 5", 3/16" x 5-1/4", 1/4" x 5-3/4"
- 1 Centre Punch: 3/16" x 6"



12 PC Jumbo Punch and Chisel Set

023505 / IPC-12

- Jumbo style for big jobs
- Vinyl pouch
- Cold Chisel: 1/2 x 6-3/4", 5/8 x 7", 3/4 x 8", 15/16 x 10", 1 x 10"
- Concrete Chisel: 1/2 x 6"
- Pin Punch: 3/8 x 8", 1/8 x 6"
- Taper Punch: 3/8 x 8", 3/16 x 10", 3/8 x 10"
- Centre Punch: 3/16" x 6"



16 PC Punch and Chisel Set

023508 / IPC-16

- Dual heat-treated Chrome Vanadium steel
- A type, shape and size for every job
- Gauge
- Cold Chisel: 3/8 x 5-1/2", 1/2 x 6", 5/8 x 6-1/2"
- Pin Punch: 3/32 x 4-1/4", 1/8 x 4-3/4", 5/32 x 5-1/4", 3/16 x 5-1/4", 1/4 x 5-3/4"
- Taper Punch: 3/32 x 5-1/4", 1/8 x 5-3/4", 5/32 x 6", 3/16 x 6-1/4", 1/4 x 6-3/4"
- Centre Punch: 1/8 x 5", 3/16" x 6"





PRY AND WRECKING BARS



4 PC Leverage Pry Bar Set

022925 / IMPB-4

- Dual material handles for sure grip
- Hardened and tempered carbon steel
- 8, 12, 18 and 24"



4 PC Rolled Head Pry Bar Set

022920 / IRPB-4

- Heat treated tempered drop forged steel
- 6", 12", 16", 20"

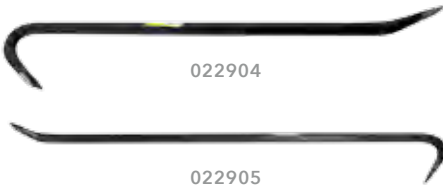

Wrecking Bars

- Hexagon shaped shank
- Precision ground chisel head and nail puller

PROD. NO.	MOD. NO.	Description
022904	IWB-24	24"
022905	IWB-36	36"



Pry Bars / Crow Bar

- Hexagon shaped shank
- Precision ground aligner point and chisel head

PROD. NO.	MOD. NO.	Description
022914	IPB-18	18"
022915	IPB-24	24"
022917	IPB-36	36"
022937	IBP-6018	18 lb x 60" Pinched Point Crow Bar



WARNING: always wear safety goggles

- 60% fibreglass handles with protective polymer jacket to prevent splintering
- Drop forged heads

Ball Pein Hammers - Fibreglass Handle

PROD. NO.	MOD. NO.	Head Weight	Handle Length
022621	IBP-08F	8oz	11"
022622	IBP-16F	16oz	12-3/4"
022623	IBP-24F	24oz	13-3/4"
022624	IBP-32F	32oz	14"



Drilling Hammers - Fibreglass Handles

PROD. NO.	MOD. NO.	Head Weight	Handle Length
022651	IDH-3F	3lb	13-3/4"
022652	IDH-4F	4lb	16"



Sledge Hammers - Fibreglass Handle

PROD. NO.	MOD. NO.	Head Weight	Handle Length
022653	ISH-4F	4lb	16"
022654	ISH-6F	6lb	30"
022655	ISH-8F	8lb	36"
022656	ISH-10F	10lb	36"
022657	ISH-12F	12lb	36"



Steel Head Hammers

PROD. NO.	MOD. NO.	Head Weight	Hammer Type
022611	ICHT-16	16oz	Claw Hammer
022612	IRHT-16	16oz	Tubular Steel Ripping Hammer



WARNING: always wear safety goggles



MISCELLANEOUS PRODUCTS

3/4" x 60' CSA Approved Electrical Tape

026702 / IET-3460

- Black tape
- Operating temperature: -7° C – 80° C
- CSA Approved
- Package Qty: 10
- Case Qty: 200

4 Row Hand Scratch Brush

026504 / ISB-4SH

- Wooden handle

Hand Riveter Set

027705 / IRT-60

- Aluminum die-cast body
- Chrome Molybdenum alloy steel jaw

Non-Contact Infrared Thermometer

027591 / IRT-520

- Allows accurate measurement of temperature without contact
- Ideal for use in inaccessible areas and where moving parts or high heat make contact measurement dangerous
- Many uses including: automotive applications, food and beverage industries, chemical industries, cement plants, road building, HVAC, pool maintenance, etc.
- Gives instant readouts
- Selectable laser pointer for accurate aim
- Backlit display for easy reading
- Automatic data hold

Specifications:

- Display: 3-1/2 digit (1999 count) LCD with backlighting
- Measuring range: -20°C to 520°C / -4°F to 968°F
- Repeatability: 2% or 3°F
- Accuracy: +/- 2°C or 2% of reading
- Operating temperature: 0°C to 41°C / 32°F to 105°F
- Response time: 1 sec appx.
- Field of view (distance : spot size): 8:1
- Spectral response: 1.7 - 18um
- Emissivity: 0.95 fixed
- Relative humidity (operating): 10-95%
- Power OFF: Automatic shut-off
- Power supply: 9V battery

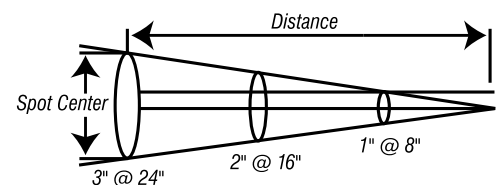

Field of view (distance : spot size) 8:1

MEASURING TOOLS



SAE / Metric Tape Measures

- High visibility steel tape
- Rubber shell for sure grip and resistance to impact

PROD. NO.	MOD. NO.	Description
022010	ITM-316	3/4" x 16'
022020	ITM-425	1" x 25'



6" SAE / Metric Electronic Digital Caliper

027515 / IEDC-6

- Large easy to read digital display
- On/Off switch prolongs battery life
- Easy switch for inch/mm readings
- Measures 0 - 6" in 1/1000" increments or 0 - 150mm in 0.01mm increments
- Plastic case



0-1" Dial Indicator

027535 / IDI-1

- Knurled bezel rotates 360°
- Stainless steel rack and contact points
- Includes revolution counter
- Easy-to-read white face dial
- Range 0 - 1", increments 0.001"
- Range per revolution 0.1"



60 Kg Magnetic Dial Indicator Stand

027541 / IMS-60

- Can be used in any position
- Fine adjustment arm allows precise setting
- On/Off switch for quick set up



027541

3-1/2 Digit Digital LCD Multimeter

027551 / IDMM-100

- 3-1/2 digit (1999 count) digital LCD display
- Low battery indicator
- Overload protection
- Designed to safety standard IEC-1010; CAT II 600V
- Includes test leads and 9V battery
- Measures DC current, AC/DC voltage, resistance, square wave output, temperature, diode check, transistor hfe



027551

SCREW EXTRACTOR SETS

5 PC Spiral Extractor Set

024205 / ISE-5

- #1 - 1/8 - 1/4"
- #2 - 1/4 - 5/16"
- #3 - 5/16 - 7/16"
- #4 - 7/16 - 9/16"
- #5 - 9/16 - 3/4"



024205

7 PC Square Extractor Set

024207 / ISE-7

- 1/8", 3/16", 15/64", 5/16", 3/8", 15/32, 9/16"



024207



024728

HAND SAWS

Adjustable Tubular Steel Hacksaw Frame

023005 / IHS-1012

- Width adjustable from 10" to 12"

FILES

5 PC File Set

023151 / IFS-5S

- Heat-treated alloy steel
- All models 2nd cut for general purpose use
- Double injected handles provide superior grip and user comfort
- 8" Flat File
- 8" Half Round File
- 8" Taper File
- 8" Round File
- 8" Square File

C-CLAMPS

- Reinforced
- Malleable steel frames

PROD. NO.	MOD. NO.	Max. Opening
024402	ICC-2	2"
024403	ICC-3	3"
024404	ICC-4	4"
024406	ICC-6	6"
024407	ICC-8	8"

VICES

Swivel Base Mechanic's Vises

- Lightweight vise precision cast from 30,000 PSI tensile strength iron
- Precision machined hardened steel jaws
- Built-in pipe jaws
- Large machined anvil
- 360° swivel base with dual lock down handles
- Shot blast finish powder coat paint for protection from corrosion

PROD. NO.	MOD. NO.	Jaw Opening	Max. Opening	Throat Opening	Pipe Capacity
024724	ISVL-4	4"	3"	2-3/16"	1-1/4"
024726	ISVL-6	6"	5"	3"	2"
024728	ISVL-8	8"	6"	3-1/2"	2-1/2"

Telescopic Magnetic Pick-Up Tool 027291 / ITM-3

- Capacity: 3.5 lb
- Extends: 5-1/4" - 28"



Telescopic Magnetic Pick-Up Tool - Extra Long 027292 / ITM-1

- Cushion-grip
- Capacity: 3.5 lb
- Extends: 6-1/4" - 33-1/4"



2-1/4" Diameter Telescoping Mirror 027293 / ITM-2

- Cushion-grip
- Mirror diameter: 2-1/4"
- Extends: 9-3/4" to 36-1/2"



2 PC Telescoping Magnetic Tool and Mirror Set 027294 / ITT-2S

- Cushion-grips
- Telescopic Magnetic Tool (027292): Capacity: 3.5 lb - Extends 6-1/4" to 33-1/4"
- Telescopic Mirror (029293): Diameter: 2-1/4" - Extends 9-3/4" to 36-1/2"



5 PC Telescopic Tool Set 027295 / ITT-5S

- Pick-up tool extends 6-1/2" - 26"
- 2" mirror extends 10" - 29"
- Articulated joints for maximum versatility
- Cushion grip handle for sure grip



6" Round Magnetic Parts Tray 027290 / IMPT-6

- Stainless steel
- Diameter: 6"





027105



027115



027116



TIE DOWNS

1" x 15' 1,500 lb Ratchet Tie Downs

- 1" heavy duty weather resistant polyester web
- Heavy duty hooks
- Quick release
- Rated capacity 1,500 lb
- Working load limit 500 lb

PROD. NO.	MOD. NO.	Description
027105	RTD-115	1/Package
027115	IRTD-1152	2/Package
027116	ITD-1154R	4/Package

2" x 30' 10,000 lb Ratchet Tie Down

027108 / RTD-230

- 2" heavy duty weather resistant polyester web
- Heavy duty hooks
- Quick release
- Rated capacity: 10,000 lb
- Breaking strength: 10,000 lb
- Working load limit: 3,300 lb

1" x 6' 1,500 lb Cam Lock Tie Down Set

027117 / ITD-164CL

- 1" heavy duty weather resistant polyester web
- Heavy duty hooks
- Quick release
- Rated capacity 1,500 lb
- Working load limit 500 lb
- 4/Package

60 PC SAE / Metric Tap and Die Set 024312 / ITD-60C

- SAE and Metric combined
- One die and tap of each
- One tap wrench and die stock
- One T-handle tap wrench
- One SAE and one Metric thread gauge
- One screwdriver
- Taps and Dies are heat treated to Rockwell C58-C61
- SAE: #4-12, 1/4-1/2" NC & NF, 1/8"-27 NPT
- SAE: #4-40NC, #6-32NC, #8-32NC, #10-22NF, #10-24NC, #12-24NC, 1/4"-20NC, 5/16"-18NC, 3/8"-16NC, 7/16" 14NC, 1/2"-13NC, 1/4"-28NF, 5/16"-24NF, 3/8"-24NF, 7/16"-20NF, 1/2"-20NF, 1/8"-27NPT
- Metric: M3 x .5, M4 x .7, M5 x .8, M6 x 1.0, M7 x 1.0, M8 x 1.23, M9 x 1.25, M10 x 1.0, M10 x 1.5, M12 x 1.75 mm



24 PC Tap and Die Sets

- Heat-treated
- Rockwell hardness C58 – C61
- Tested for strength, hardness and cutting ability
- Includes: Die stock
Tap handle

PROD. NO.	MOD. NO.	Description
024302	ITD-24	SAE 1/4"-20NC, 5/16"-18NC, 3/8"-16NC, 7/16"-14NC, 1/2"-13NC, 1/4"-28NF, 5/16"-24NF, 3/8"-24NF, 7/16"-20NF, 1/2"-20NF, 1/8"-27NPT
024303	ITD-24M	Metric M5 x .8, M6 x .75, M8 x 1.0, M10 x 1.25, M12 x 1.5, M5 x .9, M6 x 1.0, M8 x 1.25, M10 x 1.5, M12 x 1.75 mm



CABLE PULLER

2 Ton Ratchet Cable Puller 024903 / ICP-200

- All steel construction
- Drop Forged hooks with safety latches
- Heavy duty aircraft cable
- 4,000 lb pulling capacity
- Release system holds load while allowing it to be released one notch at a time





AUTOMOTIVE PRODUCTS

13 PC Slide Hammer Puller Set

027405 / ISHK-13

Includes:

- Slide hammer with 5 lb hammer
- Rear axle pulling plate
- 3-way cross head
- 2-way cross block
- Nut
- Grip wrench adapter
- Dent puller attachment and screw
- 3 pulling jaws, nuts and bolts
- Puller hook attachment
- Capacity: 2 tons

5 PC Fork Type Suspension Separator Set

022930 / IFS-5S

- Chrome Vanadium steel
- Handle
- Ball joint separator
- Tie rod separator
- Pitman arm separator
- Air hammer adapter



4 PC Pick and Hook Set

027261 / IHP-4

- Awl-straight pick
- Hook tool
- 45° bent tip tool
- 90° bent tip tool

5 PC Scraper and Remover Set

027262 / IRS-5

- 10" Multipurpose scraper
- 9" Multipurpose scraper
- 7-1/2" Scratch awl
- 7-1/2" Cotter pin puller
- Radiator hose remover

6 - 12 Volt Circuit Tester

027265 / ICT-612

- 60" rubber wire and insulated clip

Two-Way Oil Filter Wrench 027251 / IFW-002

- For filters 2-1/2" to 4-3/4" in diameter
- Three legs
- 3/8", 1/2" square and 13/16" hexagon drives



Oil Filter Strap Wrench with Swivel Handle 027252 / IFW-003

- For filters 2-7/8" to 3-1/4" diameter
- Swivel handle



Oil Filter Removal Pliers 027253 / IFP-001

- For removal of filters 2-3/4" to 3-5/8" in diameter
- Cushion handles
- Slip joint
- For removal only



Cross Wheel Wrenches

PROD. NO.	MOD. NO.	Description	Size
027201	IWW-15	15" SAE	5/8, 3/4, 13/16, 7/8"
027202	IWW-15M	15" Metric	17, 19, 21, 23 mm
027203	IWW-20	20" SAE	5/8, 3/4, 13/16, 7/8"



MacPherson Strut Coil Spring Compressor Set 027255 / ISC-200

- CrV compression screws
- Drive with 21 mm socket or any 1/2" drive ratchet or flex bar
- Not for impact use





AIR TOOLS

IMPACT WRENCHES

1/2" Drive Air Impact Wrench

028212 / II50S

- Single hammer (rocking dog) impact mechanism for good impact power with reduced vibration
- Rugged die cast aluminum body
- Compact ergonomic design for increased comfort
- Insulating and impact absorbing rubber handle grip
- 4 positive throttle settings
- Easy push button forward & reverse change mechanism
- Oil port for easy maintenance

Specifications	028212 II50S
Square Drive	1/2"
Max. Torque (ft-lb)	230 (Fwd), 236 (Rev)
Standard Bolt Capacity	5/8"
Free Speed (RPM)	7,000
Collet Size	
Overall Length	7-1/4"
Weight (lb)	5.4
Avg. Air Consumption (CFM)	4
Minimum Hose Size	3/8"
Air Inlet	1/4"

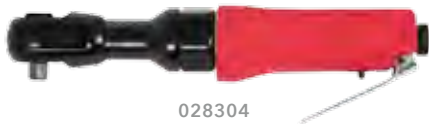

028304

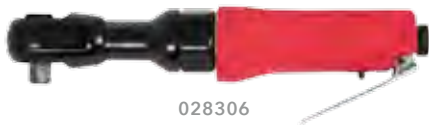

028306

Air Ratchets

- Compact head for working in tight spaces
- Insulating rubber grip for operator comfort and safety
- Lightweight aluminum body
- Air inlet screen for extended tool life

Specifications	028304 IAR38	028306 IAR12
Square Drive	3/8"	1/2"
Max. Torque (ft-lb)	50	50
Standard Bolt Capacity	3/8"	1/2"
Free Speed (RPM)	160	160
Overall Length	10-1/2"	10-1/2"
Weight (lb)	2.6	2.6
Avg. Air Consumption (CFM)	4	4
Minimum Hose Size	3/8"	3/8"
Air Inlet	1/4"	1/4"

DIE GRINDERS

1/4" Mini Die Grinder

028312 / ID25M

- Insulating rubber grip for operator safety and comfort
- Rear exhaust directs air away from work piece
- Inlet screen for extended tool life
- Safety lever prevents accidental starts

Standard accessory: Wrenches



1/4" 90° Mini Angle Head Air Die Grinder

028314 / ID25MA

- For easy access into tight spaces
- Rear exhaust directs air away from work piece
- Inlet screen for extended tool life
- Safety lever prevents accidental starts
- Grease fitting in gear head for easy maintenance

Standard accessory: Wrenches



1/4" Die Grinder

028317 / ID25R

- Insulating rubber grip for operator safety and comfort
- Rear exhaust directs air away from work piece
- Inlet screen for extended tool life
- Safety lever prevents accidental starts

Standard accessory: Wrenches



Specifications	028312 ID25M	028314 ID25MA	028317 ID25R
Free Speed (RPM)	25,000	20,000	22,000
Collet Size	1/4"	1/4"	1/4"
Overall Length	6-1/8"	6-1/4"	6-3/4"
Weight (lb)	0.8	1.1	1.3
Avg. Air Consumption (CFM)	3	3	4.5
Minimum Hose Size	3/8"	3/8"	3/8"
Air Inlet	1/4"	1/4"	1/4"





AIR TOOLS

.401 Shank Short Barrel Air Hammer with 4 Chisels

028322 / IAHS

- Teasing trigger and speed regulator match hitting power to application
- Uses standard .401 round shank steel
- Complete with quick-change spring retainer and 4 piece chisel set
- Blows per minute: 4,500
- Piston diameter: 3/4"

3/8" Reversible Air Drill

028357 / IRD38

- Convenient one hand forward and reverse lever
- Handle exhaust outlet directs air away from operator
- Complete with 3/8" chuck and key
- Spindle size 3/8" – 24UNF

6" Dual Action Air Sander

028342 / 16DA

- Provides swirl free finish
- Adjustable speed regulator for versatility
- Complete with 6" hook and loop sanding pad
- Stroke (Orbit diameter) 3/16"

	028322 IAHS	028357 IRD38	028342 16DA
SPECIFICATIONS			
Free Speed (RPM)	N/A	1,800	10,000
Overall Length	7"	7-3/8"	10"
Weight (lb)	2.9	2.5	4.26
Avg. Air Consumption (CFM)	5	4	3.3
Minimum Hose Size	3/8"	3/8"	3/8"
Air Inlet	1/4"	1/4"	1/4"

4" Angled Nozzle Blow Gun

028381 / IT-AG4AN

- Full pressure nozzle
- Brass air inlet – U.S.A. patented

General Purpose Rubber Air Hose

- Inner tube construction made from natural/synthetic oil mist resistant rubber, reinforced with high tenacity braided 1,000 denier filament yarn for added strength
- Outer cover construction is a smooth abrasion resistant black natural/synthetic rubber, for long hose life and flexibility
- 1/4" fittings – solid crush proof couplings with 8 point crimp to ensure leak proof seal
- Temperature range: -30°C to 70°C (-20°F to 160°F)
- Working pressure: 200 PSI / lb
- Burst pressure: 800 PSI / lb

PROD. NO.	MOD. NO.	IP Size	Length	Fitting NPT
028291	IAH3825R	3/8"	25'	1/4"
028292	IAH3850R	3/8"	50'	1/4"

Retractable Air Hose Reels - Metal

- Spring powered auto rewind hose reel
- High grade hardened steel spring, fully enclosed and lubricated
- All steel construction, well ribbed for strength
- Corrosion resistant powder coat finish
- Guide arm adjusts to 8 positions for floor, ceiling or wall mounting
- Four direction non-snap rollers reduce hose wear
- Multi position ratchet release mechanism locks hose in place
- Full flow solid brass swivel joint and machined brass fittings
- Ideal for shop use
- 300 PSI maximum pressure

PROD. NO.	MOD. NO.	Capacity
028271	I3825AS	3/8" x 25'
028272	I3850AS	3/8" x 50'

Retractable Air Hose Reels - Polypropylene

- Durable impact resistant polypropylene construction
- Positive latching mechanism locks hose at desired length
- Swivel bracket for wall or overhead mounting
- Complete with hose

PROD. NO.	MOD. NO.	ID Size	Length	Fitting	Application
028281	IAW3850	3/8"	50'	3/8"	Air
028282	IAW1265	1/2"	65'	3/8"	Water/Air





013480



013485



SHOP EQUIPMENT

COMPRESSORS

5 Gallon Portable Air Tank

013480 / ITPAT5

- 125 PSI maximum pressure
- Complete with pressure gauge, hose and tire chuck
- Includes safety bypass valve with manual override
- 23" long x 12" diameter

11 Gallon Portable Air Tank

013485 / ITPAT11

- 125 PSI maximum pressure
- Complete with pressure gauge, hose and tire chuck
- Includes safety bypass valve with manual override
- 23" long x 12" diameter

CREEPERS

40" Drop Shoulder Metal Frame 6 Wheel Creeper

024861 / IGC-100

- Creepers make repairs faster and easier
- Drop shoulder design for added comfort
- 40" (105cm) long reinforced tubular steel frame
- Full length extra-dense back and head rest padding for supreme comfort
- Six 2-1/2" PVC ball-bearing casters provide a smooth, highly maneuverable and stable ride
- Weight: 14 lb / 6.5 kg
- Product Dimension: 40" x 17" x 4" (1,020 x 432 x 102mm)

BENCH GRINDERS

Bench Grinders

- Spindles are all ball bearing
- Comes complete with adjustable eye shields and tool rests
- Capacitor start motor
- CUL Approved

PROD. NO.	MOD. NO.	Size	Wheel Size	Arbor Size	Motor	RPM @ 60 hz
028013	IBG-6	6"	6" x 1/2" x 1"	1/2"	1/2 HP	3,600
028014	IBG-8	8"	8" x 5/8" x 1"	5/8"	3/4 HP	3,600

32" High Bench Grinder Stand

028018 / IBGS-10

- Universal, fits 6" and 8" grinders



3 Ton Hydraulic Service Jack

024827 / ISJ-3

- Conforms to ANSI Standards
- Incorporates safety valve to prevent overloading
- Two-piece handle comes with rubber grip
- Rear swivel castors
- Capacity: 3 Tons
- Lifting range: 5-1/2" – 19-1/2"
- Chassis length: 26"
- Saddle diameter: 5-3/4"
- Weight: 92 lb



024827

5,500 lb Hydraulic Pallet Truck

024851 / IPT-55

- Easily lifts loads up to 5,500 lb
- Entry rollers at fork tip allow easy pallet entry
- Polyurethane coated steel steer wheels
- Polyurethane load rollers
- 27" x 48" fork dimensions
- Heavy duty pump for long life
- Capacity: 2-3/4 ton



024851

2 Ton Folding Engine Crane

024858 / IFEC-2T

- 4 position boom extends for hard-to-reach applications
- 4 large swivel castors provide easier positioning
- Fold-up legs reduce storage space required when not in use
- Boom length: 38.5" - 59.5"
- Base length: 67"
- Boom capacity: 2 tons
- Max. boom height: 78"
- Shipping weight: 182 lb



024858

48" Farm Jack

024837 / FJ48

- Height: 48"
- 32" long handle with grip
- Steel forged base 5.75" x 6.75"
- 4" upper foot / 4.5" lower foot
- Capacity: 3,000 kg



024837

POWER TOOLS

4-1/2" Angle Grinder

011704 / SPT145

- Motor: 4.3 Amp @ 120V
- 5/8"-11 arbor
- No load speed: 11,000 RPM
- Push-button quick change spindle lock
- Side handle fits left or right
- Adjustable wheel guard
- Includes grinding wheel
- Outer flange nut / inner flange
- Wrench
- Weight: 3.75 lb (1.7 kg)





POWER TOOLS

5" Angle Grinder

011708 / MT1221

- Motor: 8.0 Amp @ 120 V
- 5/8" - 11 arbor
- No-load speed: 11,000 RPM
- Rubber inset comfort grip
- Removable 3-position side handle
- Includes 5" grinding wheel
- Weight: 2.85 kg (6.3 lb)

10 PC Heat Gun Kit

011981 / SPT270

- Motor: 120 volt, 12.5 Amp
- Features dual heat settings and fan speeds
- Blowing speed:
 - Low: 400 litres/min (14.1 cu.ft./min)
 - High: 550 litres/min (19.4 cu.ft./min)
- Air temperature:
 - Low: 375°C (700°F)
 - High: 495°C (925°F)
- Includes:
 - Window nozzle - deflects to prevent panes of glass, etc. from overheating
 - Reflector nozzle - for soldering pipes or shrink-fitting shrink sleeves
 - Focus nozzle
 - Reduction nozzle - for focused jet of heat
 - Paint scraper for stripping paint
 - Shavehook scraper handle with 3 attachable blades
- Blow-mould case
- Weight: 0.8 kg (1.8 lb)

1/2" Drive Electric Impact Wrench

011903 / SPT124

- Motor: 7 Amp @ 120V
- 4 impact sockets: 11/16", 3/4", 13/16" and 7/8"
- Impact rate: 2,700 bpm
- Maximum torque: 230 ft/lb
- Rocker trigger for easy one-handed operation
- Rugged die-cast aluminum gear housing
- Comes in blow-mould carrying case
- Weight: 4.5 kg (10 lb)

7" Variable Speed Polisher

011712 / SPT700

- Motor: 10.0 Amp @ 120V
- Full electronic variable speed on thumb wheel: 900 - 3,000 RPM
- Metal gear housing
- Soft start motor
- Spindle lock
- Comfortable trigger switch with lock-on button
- D-shaped auxiliary handle
- Includes heavy duty backing pad and polishing bonnet
- Weight: 3.0 kg (6.8lb)



WARRANTY

WARRANTY POLICY

ITC TOOLS AND EQUIPMENT (ITC)

All ITC branded products are guaranteed against defects in workmanship and materials, when the product is used for the purpose for which it was designed, for the useful life of the tool. Any ITC product that fails during normal use and within the specified warranty period for that product will be repaired or replaced at ITC's discretion.

ITC product warranties apply to ITC products purchased new from an authorized ITC distributor to the original retail purchaser only.

See specific product warranty statements below for more information and limitations.

This warranty is void if there is evidence of misuse, abuse, alterations, or normal wear and tear. Normal wear and tear of moving parts can be repaired by purchasing the appropriate ITC replacement part.

No claim for indirect, incidental, or consequential damages of any type will be considered including loss time or wages, or loss of production. All products are sold with this specific understanding.

Product for which there is a warranty claim must be returned, freight prepaid to an authorized ITC distributor, or in the case of power tools, machinery and hydraulic equipment, to an authorized ITC OR JET warranty repair center. All returns must include proof of purchase and an explanation of the defect or failure.

Go to www.itctoolsCanada.com or www.surewerx.com for a list of authorized warranty repair centers.

Except as listed below, all ITC brand tools are covered by our Limited Lifetime Warranty

ITEMS EXCLUDED FROM WARRANTY

Cutting Tools, Drill Bits, Taps and Dies, Screw Extractors, Wood and Metal Chisels, Files, Saw Blades, Knife Blades, Electrical Tape, Reducing Adaptors, Screwdriver Bits, Batteries supplied with units, damaged insulating materials, or any tool showing rounded drive corners, snipe or hammer marks, bent or broken handles, or normal wear and tear.

ITC BRAND 1 YEAR LIMITED WARRANTY

Hydraulic Jacks, Pallet Trucks, Bench Grinders, Machinery, Cable Pullers, Service cart, Automotive Type Air Tools, Creepers, Air and Water Hose Reels, Multimeter and Thermometer (batteries excluded), Torque Wrenches (calibration is not covered by warranty except when required due to warranty repair service)

NOTE: Batteries supplied with certain products may have been exposed to a long shelf life resulting in low energy or dead batteries. Please source replacement batteries locally.

Please follow operating instructions for rechargeable batteries used in certain products.

Dead or low energy batteries do not constitute a warranty claim.

ITC POWER TOOLS

1 YEAR WARRANTY

These products are designed for use in light or intermittent duty applications. They are not intended for use in production, industrial or continual use applications.

This warranty does not extend to normal wear or consumable parts such as grinding discs, saw blades, driver bits, electrical motor brushes, worn cords, etc.

Multiple piece kits and sets- warranty applies only to the defective component, not the complete kit or set.



PROTECTIVE PRODUCTS

SAFETY AND PRODUCTIVITY

DESIGN

With features designed by Canadians for Canadians, we offer innovative designs and features that make your work clothing safer and more functional while giving you increased comfort and productivity.

QUALITY

Using only the best materials, componentry, sewing methods and constant attention to quality details, deliver on safety, fit and durability.

STANDARDS

Our products are tested in independent Canadian labs to meet and exceed all standards we state on our labels from CSA high visibility standards to CGSB, NFPA and electric arc standards and ratings. They also meet even higher standards... our own.



DID YOU KNOW?

Pioneer is the leading brand of hi-viz safety gear and also has the fastest growth and the longest history of any safety clothing brand in Canada. (Started in Vancouver in 1887)



CSA HIGH VISIBILITY SAFETY STANDARDS

The Canadian Standards Association's CSA Z96-09 High Visibility Safety Standard details the level of performance of garment componentry and design required to meet the standard classes and levels. The standard requires garment componentry to pass stringent testing including retroreflective performance, chromacity, luminance, colour fastness, resistance to shrinkage, bursting strength, tear strength, and water resistance (if applicable). Garment design elements and layout of retroreflective or combined-performance tape is another key part of the comprehensive standard. For more details, a copy of the standard can be obtained at www.csa.ca.

A simplified explanation of the CSA classes and levels for safety garments is as follows:



CLASS 1

Basic harness or safety tape over the shoulders and encircling the waist. Suitable in less complex work areas where workers are separated from car and truck traffic.

Example: Class 1 Level 2 = Class 1 tape configuration + non-retroreflective background material
Pioneer model #5590 (V1040560), hi-viz yellow/green safety sash
Pioneer model #6925BK (V1060471), black polyester fleece hoodie



CLASS 2

Full coverage of the upper torso including front, back, sides and over the shoulders. The background material must be high visibility. For use in more complex or low-light work areas requiring greater visibility.

Example Class 2 Level 2 = Class 2 tape configuration + retroreflective background material
Pioneer model #6935 (V1021150), hi-viz orange safety vest
Pioneer model #6925 (V1060460), hi-viz yellow/green polyester fleece hoodie



CLASS 3

A Class 2 garment combined with arm and leg bands. The background material must be high visibility to the standard. Hi-viz coveralls meet this standard; safety jackets and pants can be worn combined, or arm/leg bands can be added to Class 2 garments, to attain Class 3. Suitable for use in complex work areas where low light, fast-moving traffic and inclement weather are safety factors.

Example: Class 3 Level 2 = Class 3 configuration + retroreflective background material
Pioneer model #5999A (V1070161), hi-viz yellow/green traffic coverall
Pioneer model #6001J (V1070250), hi-viz orange traffic safety jacket
Pioneer model #6003P (V1070380), navy traffic safety pant

Safety officials in your region determine the appropriate class wear for specific job sites. Hazardous risk assessment should be performed by a qualified individual to determine the applicable high visibility classification.

Hi-Viz Safety Apparel 718

Surveyor Vests.....	720-721	Hi-Viz Lightweight Safety Rainwear (150D).....	740
Hi-Viz CSA Safety Vests.....	722-725	Hi-Viz PU Stretch Safety Rainwear.....	741
Hi-Viz All Purpose Vests.....	725-726	Hi-Viz Heavyweight Rainwear.....	741
Hi-Viz Accessories.....	726-727	Hi-Viz Safety Rainwear (300D/450D).....	742-743
Hi-Viz CSA T-Shirts.....	728-729	Hi-Viz 3-in-1 Safety Rainwear (450D).....	744-745
Hi-Viz CSA Long-Sleeved Shirts.....	730-731	Hi-Viz 3-in-1 Safety Rainwear (300D).....	746
Hi-Viz Hoodies.....	731-732	Hi-Viz 6-in-1 Safety Rainwear (300D/450D).....	746-748
Hi-Viz Soft Shell Jackets and Ultra Light Jackets.....	732	Hi-Viz Waterproof/Breathable Premium Jackets and Pants.....	749-750
Hi-Viz Insulated Jackets.....	733	Hi-Viz Waterproof Insulated Jackets.....	751
Poly/Cotton Coveralls And Overalls.....	734	Rain Suits.....	752
Hi-Viz Poly/Cotton Coveralls and Overalls.....	735	Québec Hi-Viz Traffic Wear.....	753
Hi-Viz Traffic Safety Wear.....	736-739	Québec Hi-Viz Traffic Rain Wear.....	754
Quilted Cotton Duck Safety Wear.....	738-739		

Flame Resistant Wear 755

FR-Tech™ 88/12 Safety Wear.....	756-761	Element FR™ Rainwear.....	773
FR Safety Vests.....	762-763	CA-43® Chemical and Acid Resistant FR Rainwear.....	774-775
FR Single-Layer Safety Wear.....	764-766	Dry Gear® FR Rainwear.....	775
FR Multi-Layer Safety Wear.....	766-768	Petro-Gard® FR Neoprene Rainwear.....	776
FR Hoodies and Pullovers.....	768-769	Utili-Gard® FR Rainwear.....	777
FR Fleece Pants.....	770	FR PU Stretch Rainwear.....	778-779
FR Underwear.....	770	FR Headwear.....	780-782
FR Shirts.....	771		
FR PVC Rainwear.....	772		

Work/Rec Apparel 783

Poly/Cotton Coveralls.....	784	Rainshield® Rainwear.....	793
Cotton Coveralls.....	784-785	PU Stretch Rainwear.....	794
Shop Coats.....	785	Heavyweight PVC/Poly/PVC Rainwear.....	795-796
Eurowear™.....	786-787	Work/Rec Rainwear.....	796-800
Knee Pads.....	788-789	Ripstop Tree Planter Rainwear.....	801
Clipper® Commercial Fishing Rainwear.....	790	Quilted Shirts, Hoodies and Vests.....	802-803
Canadian Rainwear.....	790-791	Underwear Sets.....	804
FL Snapper® Heavy-Duty Rainwear.....	791	Headwear.....	805-808
Snapper® Heavy-Duty Rainwear.....	791-792	Respirators.....	809
90° North Water-Resistant Wear.....	792	Disposable Garments.....	810-815

Footwear 816

Leather Boots.....	818-819	Ranpro Boots.....	822-823
PVC Boots.....	819-820	Safety Shoes.....	824
Waders.....	821	Socks and Sockettes.....	824-825

Welding Apparel 826

Welding Jackets and Aprons.....	827	Welding Gloves and Mitts.....	829-831
Welding Apparel Accessories.....	828-829		

Gloves 832

Seamless Knit Latex Gloves.....	834-835	PVC Gloves.....	843-844
Fitter's, Roper's and Driver's Cowgrain Gloves.....	835-837	Insulated Fitter's and Driver's Cowgrain and Piggrain Gloves.....	844-846
Mechanic's Gloves.....	837	Insulated Fitter's Cowsplit Gloves.....	847-848
Fitter's Cowsplit Gloves.....	838-839		
Knit Liners.....	840-842		

Traffic Safety 849

Traffic Safety.....	850-853	Warranty.....	856
Sizing Chart.....	854		

PeakWorks Fall Protection 858

Harnesses.....	862	Anchors and Roof Brackets.....	880
Reference Guide.....	864-865	Anchor Slings.....	881
Compliance Series.....	866	Rope Grabs and Lifelines.....	882-883
Contractor Series.....	867	Rope Grabs.....	882
PeakPro Series.....	868	Lifelines.....	883
Full Body Harness/Belt Combos.....	869	Kits.....	884-888
Belts.....	870	Roofer's Kits.....	886
Lanyards.....	871	Protection in a Pail (PIP) Kits.....	887
About Lanyards.....	872	Fall Protection Kits.....	888
Shock Absorbing Lanyards - Partially Oriented Yarn (POY).....	873	Rescue Products.....	889
Shock Absorbing Lanyards - Shock Pack (SP).....	874	Res-Q-Pole.....	889
Restraint Lanyards.....	875	Res-Q-Kit.....	889
Retractable Horizontal Lifelines - T-Line.....	876	About Confined Space.....	889
Self-Retracting Lifelines (SRL's).....	877-879	Fall Protection for Confined Space.....	890
About Self-Retracting Lifelines.....	878	Hardware and Accessories.....	891
Self-Retracting Lifelines.....	879	Peakworks Services.....	892
Anchorage Connectors.....	880-881	Standards and Regulations.....	893

ICON LEGEND

New		Flash Fire Resistant		Anti-Static	
CSA		Marine and Fish Oil		Thermal	
CSA		Tear Resistant		UPF 50+	
CSA Omega		Quick Dry		For Women	
ASTM		Packable		Water Resistant	
Anti-Fungal		Flame Resistant		Breathable	
Chemical Resistant		Arc Resistant		Waterproof	





HI-VIZ SAFETY APPAREL



SURVEYOR VESTS

Surveyor's / Supervisor's Vest

- 600 Denier oxford polyester, PU coated
- StarTech™ reflective tape
- Radiophone pocket on chest
- 12 storage pockets
- Back ruler slot
- 2 large back pack pockets
- D ring access slot

PROD. NO.	MOD. NO.	Colour	Sizes
V1010710	695	Red	S-5XL



CSA Surveyor's / Supervisor's Vest

- Tough 10 oz (350 GSM) cotton duck
- CSA Z96-09 Class 1 Level 2
- StarTech™ reflective tape
- Radiophone pocket on chest
- 10 storage pockets
- 5 pen/marker slots
- Back ruler slot
- 2 large back pack pockets
- 2 radiophone clip straps
- D ring access slot

PROD. NO.	MOD. NO.	Colour	Sizes
V1010610	694	Red	S-5XL
V1010670	694BK	Black	S-5XL

CSA Surveyor's / Supervisor's Vest

- 600 Denier oxford polyester, PU coated
- CSA Z96-09 Class 1 Level 2
- StarTech™ reflective tape
- Radiophone pocket on chest
- 10 storage pockets
- 5 pen/marker slots
- Back ruler slot
- 2 large back pack pockets
- 2 radiophone clip straps
- D ring access slot

PROD. NO.	MOD. NO.	Colour	Sizes
V1010510	693	Red	S-5XL



Hi-Viz Surveyor's Safety Vest

- 600 Denier oxford polyester, PU coated
- CSA Z96-09 Class 2 Level 2
- StarTech™ reflective tape
- Radiophone pocket on chest
- 12 storage pockets
- Back ruler slot
- 2 large back pack pockets
- Radiophone clip strap
- D ring access slot

PROD. NO.	MOD. NO.	Colour	Sizes
V1010350	6697	Hi-Viz Orange	S-4XL
V1010340	6696	Hi-Viz Yellow/Green	S-4XL



Hi-Viz Drop Shoulder Tear-Away Surveyor's Safety Vest

- 7.5 oz (260 GSM) poly/cotton
- Cooling mesh panels across the shoulders and under the arms
- CSA Z96-09 Class 2 Level 2
- StarTech™ reflective tape
- 5 point tear-away
- Brass snap front
- Chest pocket with reflective hook and loop closure on the left
- Chest pocket on the right
- Mid pocket with 2 pen slots on the left
- 2 lower pockets with flaps
- 2 radiophone clip straps
- 2 inside pockets
- Extra-long back for additional coverage
- D ring access slot

PROD. NO.	MOD. NO.	Colour	Sizes
V1010850	6694	Hi-Viz Orange	S-4XL
V1010860	6695	Hi-Viz Yellow/Green	S-4XL

NEW
NEW



Hi-Viz Surveyor's Safety Vest

- 150 Denier woven twill polyester
- CSA Z96-09 Class 2 Level 2
- StarTech™ reflective tape
- Brass snap front
- Radiophone pocket on chest
- 2 radiophone clip straps
- Cooling underarm mesh vents
- Back ruler slot
- Large back pack pouch with zipper access
- 4 front pockets with brass surveyor tape dispenser grommets
- 5 pen pockets
- 7 other all-purpose storage pockets
- D ring access slot

PROD. NO.	MOD. NO.	Colour	Sizes
V1010150	6692	Hi-Viz Orange	S-4XL
V1010140	6693	Hi-Viz Yellow/Green	S-4XL





HI-VIZ CSA SAFETY VESTS

Hi-Viz Safety Tear-Away Vest

- Tricot polyester interlock
- CSA Z96-09 Class 2 Level 2
- StarTech™ reflective tape
- ID pocket
- 5 point tear-away
- 4 sealed pockets
- Radiophone clip strap
- D ring access slot
- Adjustable 1 size up at front

PROD. NO.	MOD. NO.	Colour	Sizes
V1020951	6930	Hi-Viz Orange	S/M, L/XL, 2/3XL, 4/5XL
V1021061	6931	Hi-Viz Yellow/Green	S/M, L/XL, 2/3XL, 4/5XL

Hi-Viz Safety Vest

- Tricot polyester interlock
- 131/134 - CSA Z96-09 Class 2 Level 2
- 135/134N - CSA Z96-09 Class 1 Level 2
- StarTech™ reflective tape
- ID pocket with pen holders
- 3 storage pockets
- Cell phone pocket
- 2 radiophone clip straps
- Adjustable 1 size up at sides

PROD. NO.	MOD. NO.	Colour	Sizes
V1020250	134	Hi-Viz Orange	S/M, L/XL, 2/3XL, 4/5XL
V1020160	131	Hi-Viz Yellow/Green	S/M, L/XL, 2/3XL, 4/5XL
V1021570	135	Black	S/M, L/XL, 2/3XL, 4/5XL
V1021580	134N	Navy	S/M, L/XL, 2/3XL, 4/5XL

NEW



Hi-Viz All-Purpose Vest

- 100% polyester
- Self fabric binding on all seams
- Full front zipper
- 2 chest pockets with hook and loop closure
- 7 pockets with zipper closures
- Cell phone pocket with tab closure
- 3 pen holder slots
- Reflective bands below shoulders on front and back for better visibility
- Double layered back panel – can be used for storing maps/plans
- Adjustment tabs on both sides with metal buckles

PROD. NO.	MOD. NO.	Colour	Sizes
V1010950	696	Hi-Viz Orange	S-3XL

NEW





Hi-Viz Traffic Vest

- Polyester mesh
- CSA Z96-02 Class 2 Level 2
- StarTech™ reflective tape
- 5 point tear-away
- 4 storage pockets
- D ring access slot

PROD. NO.	MOD. NO.	Colour	Sizes
V1020750	6926	Hi-Viz Orange	Fit-All
V1020810	6927	Hi-Viz Yellow/Green	Fit-All



Hi-Viz Safety Tear-Away Mesh Back Vest

- Tricot polyester interlock front
- Full mesh back panel
- Zipper front with tear-away on left side
- 6935/6936 - CSA Z96-09 Class 2 Level 2
- 6937 - CSA Z96-09 Class 1 Level 2
- StarTech™ reflective tape
- 5 point tear-away
- 4 sealed pockets
- 2 radiophone clip straps
- D ring access slot

PROD. NO.	MOD. NO.	Colour	Sizes
V1021150	6935	Hi-Viz Orange	XS-5XL
V1021260	6936	Hi-Viz Yellow/Green	XS-5XL
V1021170	6937	Black	XS-5XL



Hi-Viz Zipper Front Safety Vest

- 3.5 oz (120 GSM) tricot polyester
- CSA Z96-09 Class 2 Level 2
- StarTech™ reflective tape
- Zipper front
- 2 radiophone clip straps
- 2 flap pockets with hook and loop closure
- 1 cell phone pocket on left chest
- 3 pen slots on right chest

PROD. NO.	MOD. NO.	Colour	Sizes
V1022150	156	Hi-Viz Orange	S-5XL
V1022160	159	Hi-Viz Yellow/Green	S-5XL





HI-VIZ CSA SAFETY VESTS

Hi-Viz Safety Tear-Away Vest

- Polyester mesh
- 6932/6933 - CSA Z96-09 Class 2 Level 2
- 6933BK - CSA Z96-09 Class 1 Level 2
- StarTech™ reflective tape
- ID pocket
- 5 point tear-away
- 4 sealed pockets
- Radiophone clip strap
- D ring access slot
- Adjustable 1 size up at front

PROD. NO.	MOD. NO.	Colour	Sizes
V1021450	6932	Hi-Viz Orange	S/M, L/XL, 2/3XL, 4/5XL
V1021560	6933	Hi-Viz Yellow/Green	S/M, L/XL, 2/3XL, 4/5XL
V1021470	6933BK	Black	S/M, L/XL, 2/3XL, 4/5XL

Hi-Viz Safety Vest with Snaps

- 3.5 oz (120 GSM) polyester mesh
- CSA Z96-09 Class 2 Level 2
- StarTech™ reflective tape
- ID pocket
- Snap button front
- 5 point tear-away
- Extra-comfortable tear-away chest panels
- 2 flap pockets with hook and loop closure
- 1 cell phone pocket on left chest
- 3 pen slots on right chest
- D ring access slot

PROD. NO.	MOD. NO.	Colour	Sizes
V1021950	6938	Hi-Viz Orange	S-5XL
V1021960	6939	Hi-Viz Yellow/Green	S-5XL

NEW

NEW

Hi-Viz Women's Safety Vest

- Tricot polyester interlock
- 136/139 - CSA Z96-09 Class 2 Level 2
- 139BK/139PK - CSA Z96-09 Class 1 Level 2
- StarTech™ reflective tape
- ID pocket with pen holders
- Full front zipper
- Storage, cell phone and inside pockets
- Radiophone clip strap
- Designed for women with a tapered waist and flared bottom



PROD. NO.	MOD. NO.	Colour	Sizes
V1021850	136	Hi-Viz Orange	Women's XS-2XL
V1021860	139	Hi-Viz Yellow/Green	Women's XS-2XL
V1021870	139BK	Black	Women's XS-2XL
V1021840	139PK	Pink	Women's XS-2XL

NEW



HI-VIZ CSA SAFETY VESTS



Hi-Viz Reversible Fleece Lined Vest

- 300 Denier oxford polyester
- CSA Z96-09 Class 2 Level 2
- StarTech™ reflective tape
- Reversible to become a black fleece vest
- Long back weather-protective tail
- Radiophone clip strap
- Full front reversible zipper
- Invisible embroidery access zipper
- 2 zipper pockets
- 2 slash pockets

PROD. NO.	MOD. NO.	Colour	Sizes
V1020350	6698	Hi-Viz Orange	S-3XL
V1020460	6699	Hi-Viz Yellow/Green	S-3XL



HI-VIZ ALL-PURPOSE VESTS

Hi-Viz All-Purpose Vest

- Polyester mesh
- Yellow PVC reflective tape
- 5 point tear-away
- ID and pen pockets
- 3 storage pockets
- Radiophone clip strap
- D ring access slot

PROD. NO.	MOD. NO.	Colour	Sizes
V1030150	145	Hi-Viz Orange	Fit-All



Hi-Viz All-Purpose Vest

- Coated polyester mesh
- Yellow PVC reflective tape
- 5 point tear-away

PROD. NO.	MOD. NO.	Colour	Sizes
V1030350	592	Hi-Viz Orange	Fit-All



Hi-Viz All-Purpose Vest

- Coated polyester mesh
- CSA Z96-09 Class 1 Level 2
- StarTech™ reflective tape
- 5 point tear-away

PROD. NO.	MOD. NO.	Colour	Sizes
V1030410	596	Hi-Viz Orange	Fit-All





HI-VIZ ALL PURPOSE VESTS

Hi-Viz Tear-Away Mesh Vest

- Polyester mesh
- CSA Z96-09 Class 2 Level 2
- StarTech™ reflective tape
- 5 point tear-away
- D ring access slot
- Adjustable 1 size up at front
- 597P - Packed in hangable bag

PROD. NO.	MOD. NO.	Colour	Sizes
V1030550	597	Hi-Viz Orange	S/M, L/XL, 2/3XL, 4/5XL
V1030650	597P	Hi-Viz Orange	S/M, L/XL, 2/3XL, 4/5XL



HI-VIZ ACCESSORIES

Adjustable Reflective Arm Band 14" x 4"

- 14" x 4" adjustable arm band
- StarTech™ reflective tape, conforms to CSA Z96-09 standards

PROD. NO.	MOD. NO.	Colour	Sizes
V1040150	140	Hi-Viz Orange	Fit-All
V1040160	141	Hi-Viz Yellow/Green	Fit-All

Adjustable Reflective Ankle Band 18" x 4"

- 18" x 4" adjustable ankle band
- StarTech™ reflective tape, conforms to CSA Z96-09 standards

PROD. NO.	MOD. NO.	Colour	Sizes
V1040250	142	Hi-Viz Orange	Fit-All
V1040260	143	Hi-Viz Yellow/Green	Fit-All

Name Badge Holder

- Individually packaged
- Holds identification card or badge
- Attaches easily over any chest radiophone strap

PROD. NO.	MOD. NO.	Colour	Sizes
V1040570	144	Transparent	3.5" W x 4" L



Hi-Viz Safety Sash

- Premium 4" elastic waist
- CSA Z96-09 Class 1 Level 2
- StarTech™ reflective tape
- Storage pocket on left strap
- 2 point tear-away

PROD. NO.	MOD. NO.	Colour	Sizes
V1040560	5590	Hi-Viz Yellow/Green	Fit-All



Hi-Viz Safety Sash

- Premium 2" elastic
- Adjustable elastic waist band and chest straps
- StarTech™ reflective tape
- 4 point tear-away
- Quick-release waist buckle

PROD. NO.	MOD. NO.	Colour	Sizes
V1040850	5591	Hi-Viz Orange	Fit-All
V1040860	5592	Hi-Viz Yellow/Green	Fit-All



Hi-Viz Safety Sash

- 100% polyester
- PVC yellow reflective tape
- Storage pocket on left strap
- Adjustable elastic waist and chest bands

PROD. NO.	MOD. NO.	Colour	Sizes
V1040950	5593	Hi-Viz Orange	Fit-All



Hi-Viz CSA 4" Wide Adjustable Safety Sash

- Hi-viz polyester tricot double-layered backing fabric
- 2" sewn-on StarTech™ reflective tape
- CSA Z96-09 Class 1 Level 2
- Lightweight packable design
- Adjustable hook and loop closure on chest
- Adjustable belt on waist

PROD. NO.	MOD. NO.	Colour	Sizes
V1040350	5490	Hi-Viz Orange	Fit-All
V1040450	5491	Hi-Viz Orange	Fit-All (Tall)
V1040360	5492	Hi-Viz Yellow/Green	Fit-All
V1040460	5493	Hi-Viz Yellow/Green	Fit-All (Tall)





HI-VIZ CSA T-SHIRTS

Hi-Viz Traffic T-Shirt

- Polyester mesh
- CSA Z96-09 Class 2 Level 2
- StarTech™ reflective tape
- Radiophone clip strap
- Chest pocket with hook and loop closure
- Comfortable rib knit collar

PROD. NO.	MOD. NO.	Colour	Sizes
V1050350	5994	Hi-Viz Orange	S-5XL
V1050360	5997	Hi-Viz Yellow/Green	XS-5XL

Hi-Viz Traffic T-Shirt

- Polyester mesh
- CSA Z96-09 Class 2 Level 2
- StarTech™ reflective tape
- 5992/5993 - Radiophone clip strap
- 5992P/5993P - Packed in hangable bag

PROD. NO.	MOD. NO.	Colour	Sizes
V1050150	5992	Hi-Viz Orange	S-3XL
V1050450	5992P	Hi-Viz Orange	S-3XL
V1050260	5993	Hi-Viz Yellow/Green	S-3XL
V1050460	5993P	Hi-Viz Yellow/Green	S-3XL

NEW

NEW



Hi-Viz Traffic Micro Mesh T-Shirt

- 3.7 oz (125 GSM) micro mesh quick-dry
- CSA Z96-09 Class 2 Level 2
- StarTech™ reflective tape
- Radiophone clip strap
- Chest pocket with hook and loop closure



PROD. NO.	MOD. NO.	Colour	Sizes
V1050650	6979	Hi-Viz Orange	S-5XL
V1050660	6989	Hi-Viz Yellow/Green	S-5XL



Cotton Safety T-Shirt

- 100% cotton jersey knit
- Self fabric crew neck
- CSA Z96-09 Class 1 Level 2
- StarTech™ reflective tape
- Reflective patch on each sleeve
- Radiophone clip strap
- Chest pocket with hook and loop closure

PROD. NO.	MOD. NO.	Colour	Sizes
V1050550	6978	Orange	S-4XL
V1050560	6980	Yellow/Green	S-4XL
V1050570	6976	Black	S-4XL





Birdseye Safety Polo Shirt

- Soft premium birdseye moisture-wicking polyester
- 6986/6987 - CSA Z96-09 Class 2 Level 2
- 6988 - CSA Z96-09 Class 1 Level 2
- StarTech™ reflective tape
- Rib polo collar with contrast stripes
- Chest pocket with hook and loop closure
- Radiophone clip strap



PROD. NO.	MOD. NO.	Colour	Sizes
V1051350	6986	Hi-Viz Orange	S-5XL
V1051360	6987	Hi-Viz Yellow/Green	XS-5XL
V1051370	6988	Black	S-5XL



Women's Birdseye Safety Polo Shirt

- Soft premium birdseye moisture-wicking polyester
- CSA Z96-09 Class 1 Level 2
- StarTech™ reflective tape
- Rib polo collar with contrast stripes
- Chest pocket with hook and loop closure • Radiophone clip strap



PROD. NO.	MOD. NO.	Colour	Sizes
V1051510	6999	Pink	Women's XS-3XL



Ultra-Cool, Ultra-Breathable Safety T-Shirt

- Ultra-breathable and moisture-wicking CoolPass® fabric
- Cool and breathable zebra-style reflective tape
- CSA Z96-09 Class 2 Level 2
- UPF 50+ UV protection
- Reflective patch on each sleeve • Rib V-neck



PROD. NO.	MOD. NO.	Colour	Sizes
V1052150	6900	Hi-Viz Orange	S-4XL
V1052160	6901	Hi-Viz Yellow/Green	XS-4XL



Birdseye Safety T-Shirt

- Soft premium birdseye moisture-wicking polyester
- 6990/6990R/6991 - CSA Z96-09 Class 2 Level 2
- 6992 - CSA Z96-09 Class 1 Level 2
- StarTech™ reflective tape
- 6990R - Reflective patch on each sleeve
- Rib crew neck
- Chest pocket with hook and loop closure • Radiophone clip strap



PROD. NO.	MOD. NO.	Colour	Sizes
V1051150	6990	Hi-Viz Orange	XS-5XL
V105115R	6990R	Hi-Viz Orange	S-4XL
V1051160	6991	Hi-Viz Yellow/Green	XS-5XL
V1051170	6992	Black	XS-5XL





HI-VIZ CSA LONG-SLEEVED SHIRTS

Ultra-Cool, Ultra-Breathable Long-Sleeved Safety Shirt

- Ultra-breathable and moisture-wicking CoolPass® fabric
- Cool and breathable zebra-style reflective tape
- CSA Z96-09 Class 2 Level 2
- UPF 50+ UV protection
- Rib V-neck and cuffs



PROD. NO.	MOD. NO.	Colour	Sizes
V1052250	6904	Hi-Viz Orange	S-4XL
V1052260	6905	Hi-Viz Yellow/Green	XS-4XL



Birdseye Long-Sleeved Safety Shirt

- Soft premium birdseye moisture-wicking polyester
- 6995/6996 - CSA Z96-09 Class 2 Level 2
- 6997 - CSA Z96-09 Class 1 Level 2
- StarTech™ reflective tape
- Rib crew neck
- Chest pocket with hook and loop closure
- Radiophone clip strap



PROD. NO.	MOD. NO.	Colour	Sizes
V1051250	6995	Hi-Viz Orange	XS-5XL
V1051260	6996	Hi-Viz Yellow/Green	XS-5XL
V1051270	6997	Black	XS-5XL



Cotton Long-Sleeved Safety Shirt

- 100% cotton jersey knit
- Self fabric crew neck
- CSA Z96-09 Class 1 Level 2
- StarTech™ reflective tape
- Radiophone clip strap
- Chest pocket with hook and loop closure

PROD. NO.	MOD. NO.	Colour	Sizes
V1050850	6981	Orange	S-4XL
V1050860	6982	Yellow/Green	S-4XL



Hi-Viz Traffic Micro Mesh Long-Sleeved Safety Shirt

- 3.7 oz (125 GSM) micro mesh quick-dry
- CSA Z96-09 Class 2 Level 2
- StarTech™ reflective tape
- Radiophone clip strap
- Chest pocket with hook and loop closure



PROD. NO.	MOD. NO.	Colour	Sizes
V1050950	6984	Hi-Viz Orange	S-5XL
V1050960	6985	Hi-Viz Yellow/Green	S-5XL



HI-VIZ CSA LONG-SLEEVED SHIRTS



Birdseye Long-Sleeved Safety Polo Shirt

- Soft premium birdseye moisture-wicking polyester
- 6993/6994 - CSA Z96-09 Class 2 Level 2
- 6998 - CSA Z96-09 Class 1 Level 2
- StarTech™ reflective tape
- Rib polo collar with contrast stripes
- Chest pocket with hook and loop closure
- Radiophone clip strap



PROD. NO.	MOD. NO.	Colour	Sizes
V1051450	6993	Hi-Viz Orange	S-5XL
V1051460	6994	Hi-Viz Yellow/Green	XS-5XL
V1051470	6998	Black	S-5XL



HI-VIZ HOODIES

Hi-Viz Polyester Fleece Hoodie

- Premium 10.5 oz (360 GSM) polyester fleece
- 6924/6925 - CSA Z96-09 Class 2 Level 2 (becomes Class 3 when worn with hi-viz pant featuring reflective leg bands)
- 6925BK - CSA Z96-09 Class 1 Level 2
- Double-stitched StarTech™ reflective tape
- Zips into inner zipper on 5575A/5585A to make 3-in-1 jacket (optional, sold separately)
- Detachable drawstring hood
- Elastic cuffs and hem
- 2 front slash pockets
- Full front reversible zipper
- 2 radiophone clip straps

PROD. NO.	MOD. NO.	Colour	Sizes
V1060350	6924	Hi-Viz Orange	S-5XL
V1060460	6925	Hi-Viz Yellow/Green	XS-5XL
V1060471	6925BK	Black	S-5XL



Hi-Viz Micro Fleece Zip Hoodie

- 7 oz (240 GSM) micro fleece
- 4-way comfort stretch
- 6940/6941 - CSA Z96-09 Class 2 Level 2
- 6942 - CSA Z96-09 Class 1 Level 2
- StarTech™ reflective tape
- Full front zipper
- Detachable drawstring hood
- Elastic cuffs and hem
- 2 front slash pockets
- 2 radiophone clip straps

PROD. NO.	MOD. NO.	Colour	Sizes
V1060550	6940	Hi-Viz Orange	S-5XL
V1060560	6941	Hi-Viz Yellow/Green	XS-5XL
V1060570	6942	Black	S-5XL





HI-VIZ HOODIES

Hi-Viz Polyester Fleece Boa Lined Hoodie

- Premium polyester fleece with warm laminated boa inner lining
- 6920/6921 - CSA Z96-09 Class 2 Level 2
- 6921BK - CSA Z96-09 Class 1 Level 2
- StarTech™ reflective tape
- Adjustable hem and hood
- Radiophone clip strap
- 2 front slash pockets
- Full front zipper



PROD. NO.	MOD. NO.	Colour	Sizes
V1060150	6920	Hi-Viz Orange	S-4XL
V1060260	6921	Hi-Viz Yellow/Green	S-4XL
V1060270	6921BK	Black	S-4XL

HI-VIZ SOFT SHELL JACKETS AND ULTRA LIGHT JACKETS

Hi-Viz Soft Shell Safety Jacket

- Premium, multi-layer, 4-way 10 oz (350 GSM) soft shell stretch fabric
- CSA Z96-09 Class 2 Level 2
- StarTech™ reflective tape
- Water resistant and breathable
- Detachable hood
- Comfort fleece collar
- 2 zip front pockets
- Adjustable hem and wrists



PROD. NO.	MOD. NO.	Colour	Sizes
V1100150	5579	Hi-Viz Orange	S-3XL
V1100160	5589	Hi-Viz Yellow/Green	S-3XL



"Comfort Plus" Safety Ultra Light Working/Biking Jacket

- Ultra-light and flexible micro fibre pongee fabric
- Breathable and water-repellent
- Heat-pressed StarTech™ 2" reflective tape
- CSA Z96-09 Class 1 Level 2
- Full front zipper
- Back vent
- Adjustable hem and cuffs
- Zippered chest pocket and lower slash pockets
- Extra-long back for additional coverage
- Trimmed with black panels under arms and on both sides

PROD. NO.	MOD. NO.	Colour	Sizes
V1180160	5660	Yellow/Green	XS-4XL

NEW

HI-VIZ INSULATED JACKETS



Hi-Viz Quilted Freezer Jacket

- Woven diamond quilted polyester with 3.5 oz (120 GSM) insulation
- Double-stitched StarTech™ reflective tape
- 5015/5016 - CSA Z96-09 Class 2 Level 2
- 5017 - CSA Z96-09 Class 1 Level 2
- Rib knit gusseted action back for working comfort
- Rib knit cuffs
- 2 front slash pockets
- 3 inside storage pockets: 2 lower, 1 chest cell phone
- Black micro fleece comfort collar



PROD. NO.	MOD. NO.	Colour	Sizes
V1170150	5015	Hi-Viz Orange	S-5XL
V1170160	5016	Hi-Viz Yellow/Green	XS-5XL
V1170170	5017	Black	S-5XL





POLY/COTTON COVERALLS AND OVERALLS

Safety Poly/Cotton Coverall

- 65% polyester 35% cotton, 7 oz (230 GSM)
- 5514/5514T - CSA Z96-09 Class 3 Level 2
- 516/516T/5516/5516T - CSA Z96-09 Class 1 Level 2
- StarTech™ reflective tape
- 2-way heavy-duty brass zipper
- 22" boot access brass zippers (516/516T only)
- Adjustable snap wrists
- 7 storage pockets: 2 back, 2 chest, 2 side, 1 tool
- 2 pass-through pockets
- Action back and elastic waist

PROD. NO.	MOD. NO.	Colour	Sizes
V2020680	516	Navy	36-60
V202068T	516T	Navy	40T-60T
V2020510	5514	Orange	36-60
V202051T	5514T	Orange	40T-60T
V2020580	5516	Navy	36-60
V202058T	5516T	Navy	40T-60T

NEW
NEW

22" boot access brass zippers (516/516T only)



Safety Poly/Cotton Overall

- 7 oz (230 GSM) poly/cotton
- 6617/6617T - CSA Z96-09 Class 2 Level 2 (becomes Class 3 when worn with CSA Class 2 Level 2 top featuring reflective arm bands)
- 6615/6615T - CSA Z96-09 Class 1 Level 2 (becomes Class 3 when worn with CSA Class 2 Level 2 top featuring reflective arm bands)
- StarTech™ reflective tape
- 2-way heavy-duty brass zipper
- Adjustable elastic suspenders
- 7 storage pockets: 2 back, 2 chest, 2 side, 1 tool
- 2 pass-through pockets
- Hammer loop

PROD. NO.	MOD. NO.	Colour	Sizes
V2030110	6617	Orange	36-60
V203011T	6617T	Orange	40T-60T
V2030180	6615	Navy	36-60
V203018T	6615T	Navy	40T-60T





Hi-Viz Safety Poly/Cotton Coverall

- 5518/5518T/5519/5519T - 7.5 oz (260 GSM) hi-viz fluorescent 65% polyester 35% cotton twill fabric
- 5519BK/5519BK T - 7 oz (240 GSM) poly/cotton TC
- Hi-tech comfortable weave of cotton on the inside and polyester on the outside
- 5518/5518T/5519/5519T - CSA Z96-09 Class 3 Level 2
- 5519BK/5519BK T - CSA Z96-09 Class 1 Level 2
- StarTech™ reflective tape
- SBS brass 2-way zipper front
- 18" brass 2-way boot zippers/leg vents
- Elastic waist and action back
- Snap wrists
- Chest pockets with radiophone clip straps
- Side pocket with double bottom pocket back
- 4 pockets: 2 pass-through, 2 rear

PROD. NO.	MOD. NO.	Colour	Sizes
V1160150	5518	Hi-Viz Orange	S-5XL
V116015T	5518T	Hi-Viz Orange	S-5XL (Tall)
V1160160	5519	Hi-Viz Yellow/Green	XS-5XL
V116016T	5519T	Hi-Viz Yellow/Green	S-5XL (Tall)
V1160170	5519BK	Black	S-5XL
V116017T	5519BK T	Black	S-5XL (Tall)

18" leg zippers



Hi-Viz Safety Poly/Cotton Overall

- 6618/6619 - 7.5 oz hi-viz (260 GSM) hi-viz fluorescent 65% polyester 35% cotton twill fabric
- 6619BK - 7 oz (240 GSM) poly/cotton TC
- Hi-tech comfortable weave of cotton on the inside and polyester on the outside
- 6618/6619 - CSA Z96-09 Class 2 Level 2 (becomes Class 3 when worn with CSA Class 2 Level 2 top featuring reflective arm bands)
- 6619BK - CSA Z96-09 Class 1 Level 2 (becomes Class 3 when worn with CSA Class 2 Level 2 top featuring reflective arm bands)
- StarTech™ reflective tape
- SBS brass 2-way zipper front
- 18" brass 2-way boot zippers/leg vents
- Side pocket with double bottom pocket back
- 6 pockets: 2 chest, 2 pass-through, 2 rear
- Elastic suspenders
- Hammer loop

PROD. NO.	MOD. NO.	Colour	Sizes
V1160250	6618	Hi-Viz Orange	S-5XL
V1160260	6619	Hi-Viz Yellow/Green	XS-5XL
V1160270	6619BK	Black	S-5XL





HI-VIZ TRAFFIC SAFETY WEAR

Hi-Viz Traffic Safety Jacket

- Polyester knit
- 6001J/5999J - CSA Z96-09 Class 2 Level 2 (becomes Class 3 when worn with hi-viz pant featuring reflective leg bands)
- 6003J - CSA Z96-09 Class 1 Level 2
- StarTech™ reflective tape
- Mesh ventilation panels on upper arms
- 2-way brass zipper
- 2 radiophone clip straps
- Adjustable snap wrists
- 5 storage pockets: 2 chest, 2 front slash, 1 cell phone

PROD. NO.	MOD. NO.	Colour	Sizes
V1070250	6001J	Hi-Viz Orange	XS-5XL
V1070260	5999J	Hi-Viz Yellow/Green	XS-5XL
V1070280	6003J	Navy	XS-5XL

Mesh ventilated upper arms

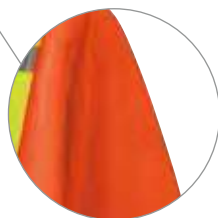

Hi-Viz Traffic Safety Pant

- Polyester knit
- CSA Z96-09 Class 3 Level 2 when worn with CSA Class 2 Level 2 top featuring reflective arm bands
- StarTech™ reflective tape
- Mesh ventilation panels on upper legs
- Brass zipper fly access
- 2-way 28" leg zippers for ventilation and easy boot access
- 5 storage pockets: 2 side, 2 back, 1 tool
- Elastic waist with drawstring

PROD. NO.	MOD. NO.	Colour	Sizes
V1070350	6001P	Hi-Viz Orange	XS-4XL
V1070360	5999P	Hi-Viz Yellow/Green	XS-4XL
V1070380	6003P	Navy	XS-4XL

Mesh ventilated upper legs

28" leg zippers



Hi-Viz Traffic Safety Coverall

- Polyester knit
- 6001/5999A - CSA Z96-09 Class 3 Level 2
- 6003 - CSA Z96-09 Class 1 Level 2
- StarTech™ reflective tape
- Mesh ventilation panels on upper arms and legs
- 2-way brass zipper
- 2 radiophone clip straps
- 2-way 28" leg zippers for ventilation and easy boot access
- Adjustable snap wrists
- 7 storage pockets: 2 rear, 2 chest, 2 side, 1 tool
- Hammer loop
- 2 pass-through pockets
- Elastic waist



PROD. NO.	MOD. NO.	Colour	Sizes
V1070150	6001	Hi-Viz Orange	XS-5XL
V1070161	5999A	Hi-Viz Yellow/Green	XS-5XL
V1070180	6003	Navy	XS-5XL

Hi-Viz Traffic Safety Overall

- Polyester knit
- 6002/6000 - CSA Z96-09 Class 2 Level 2 (becomes Class 3 when worn with CSA Class 2 Level 2 top featuring reflective arm bands)
- 6004 - CSA Z96-09 Class 1 Level 2 (becomes Class 3 when worn with CSA Class 2 Level 2 top featuring reflective arm bands)
- StarTech™ reflective tape
- Mesh ventilation panels on upper legs
- 2-way brass zipper
- Radiophone clip strap
- 2-way 28" leg zippers for ventilation and easy boot access
- 7 storage pockets: 2 rear, 2 chest, 2 side, 1 tool
- Hammer loop
- 2 pass-through pockets
- Elastic waist and suspenders



PROD. NO.	MOD. NO.	Colour	Sizes
V1070450	6002	Hi-Viz Orange	XS-4XL
V1070460	6000	Hi-Viz Yellow/Green	XS-4XL
V1070480	6004	Navy	XS-4XL



QUILTED COTTON DUCK SAFETY WEAR

Quilted Cotton Duck Safety Coverall

- 100% cotton duck canvas, 10.5 oz (350 GSM) with 6.5 oz (220 GSM) poly filling
- 5540A/5539BKA/5539A - CSA Z96-09 Class 1 Level 2
- 5540A/5539BKA/5539A - Double-stitched StarTech™ reflective tape with combined-performance trim
- 2-way brass zipper
- 5540A/5539BKA/5539 - Radiophone clip strap
- 6 storage pockets: 2 back, 2 chest, 2 front
- Elastic waist, foot straps and wrists
- Hip-to-ankle brass zipper on each side
- Hammer loop
- Snaps on collar to attach 539/538BK/538 hood (sold separately)



PROD. NO.	MOD. NO.	Colour	Sizes
V206095A	5540A	Orange	S-4XL
V206097A	5539BKA	Black	S-4XL
V206098A	5539A	Navy	S-4XL
V206017A	520A	Black	S-4XL



Hip to ankle leg zips/vents

Quilted Cotton Duck Safety Overall

- 100% cotton duck canvas, 10.5 oz (350 GSM) with 6.5 oz (220 GSM) poly filling
- CSA Z96-09 Class 1 Level 2 (becomes Class 3 when worn with CSA Class 2 Level 2 top featuring reflective arm bands)
- Double-stitched StarTech™ reflective tape with combined-performance trim
- 2-way brass zipper
- Radiophone clip strap
- Adjustable elastic suspenders
- 4 storage pockets: 2 front, 2 back
- Elastic foot straps
- Hip-to-ankle brass zipper on each side
- Hammer loop
- Reinforced knees



PROD. NO.	MOD. NO.	Colour	Sizes
V2060550	5538	Orange	XS-4XL
V2060570	5536BK	Black	XS-4XL
V2060580	5536	Navy	S-4XL



Hip to ankle leg zips/vents

QUILTED COTTON DUCK SAFETY WEAR



Quilted Cotton Duck Safety Parka

- 100% cotton duck canvas, 10.5 oz (350 GSM) with 6.5 oz (220 GSM) poly filling
- CSA Z96-09 Class 1 Level 2
- Double-stitched StarTech™ reflective tape with combined-performance trim
- Brass zipper plus snap closure storm placket
- Radiophone clip strap
- 5 storage pockets: 4 front, 1 inside chest
- Drawstring waist and storm cuffs
- Snaps on collar to attach 539/538BK/538 hood (sold separately)



PROD. NO.	MOD. NO.	Colour	Sizes
V206035A	5537A	Orange	S-4XL
V206037A	5535BKA	Black	XS-4XL
V206038A	5535A	Navy	S-4XL



Quilted Cotton Duck Safety Bomber

- 100% cotton duck canvas, 10.5 oz (350 GSM) with 6 oz (220 GSM) quilted poly filling
- CSA Z96-09 Class 1 Level 2
- Double-stitched StarTech™ reflective tape with combined-performance trim
- Full front zipper with placket
- Radiophone clip strap
- Cell pocket with flap on left side
- 2 lower slash pockets, pocket on left arm
- Elastic rib cuffs and hem
- Snaps on collar to attach 539/538BK/538 hood (sold separately)



PROD. NO.	MOD. NO.	Colour	Sizes
V2060450	5546	Orange	S-4XL
V2060480	5545	Navy	S-4XL



Hood for Quilted Cotton Duck Safety Parka, Bomber or Coverall

- 100% cotton duck canvas, 10.5 oz (350 GSM) with 6.5 oz (220 GSM) poly filling



PROD. NO.	MOD. NO.	Colour	Sizes
V2060250	539	Orange	Fit-All
V2060270	538BK	Black	Fit-All
V2060280	538	Navy	Fit-All





HI-VIZ LIGHTWEIGHT SAFETY RAINWEAR (150D)

Hi-Viz 150D Lightweight Waterproof Safety Jacket with Detachable Hood

- 150 Denier PU coated polyester, 10 oz (350 GSM)
- 100% waterproof and windproof
- CSA Z96-09 Class 2 Level 2 (becomes Class 3 when worn with hi-viz pant featuring reflective leg bands)
- StarTech™ reflective tape
- Taped and heat sealed seams
- Extra liberal fit for working comfort
- Multiple front and back vents
- Fully mesh lined
- Adjustable wrists
- 2 large front cargo pockets
- Detachable and adjustable hood, folds into comfort fleece collar
- Full front zipper with storm placket



PROD. NO.	MOD. NO.	Colour	Sizes
V1090150	5594	Hi-Viz Orange	XS-5XL
V1090160	5596	Hi-Viz Yellow/Green	XS-5XL

Hi-Viz 150D Lightweight Waterproof Safety Bib Pant

- 150 Denier PU coated polyester, 10 oz (350 GSM)
- 100% waterproof and windproof
- CSA Z96-09 Class 3 Level 2 when worn with CSA Class 2 Level 2 top featuring reflective arm bands
- StarTech™ reflective tape
- Taped and heat sealed seams
- Extra liberal fit for working comfort
- Elastic suspenders with quick-release clips
- Boot access zippers with adjustable ankles
- Fly access



PROD. NO.	MOD. NO.	Colour	Sizes
V1090250	5595	Hi-Viz Orange	XS-5XL
V1090260	5597	Hi-Viz Yellow/Green	XS-5XL

Hi-Viz 150D Lightweight Waterproof Safety Pant

- 150 Denier PU coated polyester, 10 oz (350 GSM)
- 100% waterproof and windproof
- CSA Z96-09 Class 3 Level 2 when worn with CSA Class 2 Level 2 top featuring reflective arm bands
- StarTech™ reflective tape
- Taped and heat sealed seams
- Back pocket with snap
- Elastic drawstring waist with toggle
- Extra liberal fit for working comfort



PROD. NO.	MOD. NO.	Colour	Sizes
V1090350	5600	Hi-Viz Orange	XS-5XL
V1090360	5601	Hi-Viz Yellow/Green	XS-5XL

HI-VIZ PU STRETCH SAFETY RAINWEAR



PU Stretch Hi-Viz Waterproof Safety Jacket

- 100% waterproof polyurethane
- CSA Z96-09 Class 2 Level 2 (becomes Class 3 when worn with hi-viz pant featuring reflective leg bands)
- StarTech™ reflective tape
- Lightweight and tough 4-way stretch fabric
- Polyester tricot lining transfers body perspiration
- Remains flexible in cold temperatures
- Oil and chemical resistant
- 2 front pockets
- Heat welded seams
- Full zipper with snap closure storm placket
- Hood folds into collar
- Adjustable wrists



PROD. NO.	MOD. NO.	Colour	Sizes
V1140150	D71250J	Hi-Viz Orange	XS-5XL
V1140160	D7125YJ	Hi-Viz Yellow/Green	XS-5XL

PU Stretch Hi-Viz Waterproof Safety Bib Pant

- 100% waterproof polyurethane
- CSA Z96-09 Class 3 Level 2 when worn with CSA Class 2 Level 2 top featuring reflective arm bands
- StarTech™ reflective tape
- Lightweight and tough 4-way stretch fabric
- Polyester tricot lining transfers body perspiration
- Remains flexible in cold temperatures
- Oil and chemical resistant
- Heat welded seams
- Heavy-duty suspenders with quick-release clips
- Adjustable snap ankles



PROD. NO.	MOD. NO.	Colour	Sizes
V1140250	D71250P	Hi-Viz Orange	XS-5XL
V1140260	D7125YP	Hi-Viz Yellow/Green	XS-5XL

HI-VIZ HEAVYWEIGHT RAINWEAR

PVC Waterproof Safety Jacket and Hood

- Heavyweight premium .45 mm heavy-duty PVC coated polyester/PVC
- PVC reflective tape
- 100% waterproof
- Tough, triple-welded seams
- Double brass snap storm placket closure



D1003

D1000

PROD. NO.	MOD. NO.	Colour	Sizes
V3030150	D1000	Hi-Viz Orange	XS-5XL
V3030250	D1003	Hi-Viz Orange	Fit-All



HI-VIZ SAFETY RAINWEAR (300D/450D)

300D Hi-Viz Ripstop Waterproof Safety Jacket

- 300 Denier durable ripstop polyester, PU coated
- 100% waterproof and windproof
- Double-stitched and heat sealed seams
- Abrasion-, puncture- and tear-resistant
- CSA Z96-09 Class 2 Level 2 (becomes Class 3 when worn with hi-viz pant featuring reflective leg bands)
- StarTech™ reflective tape
- Multiple ventilation panels, front and back
- Fully mesh and taffeta lined
- Drop back
- 2 lower zip pockets, 2 lower inside pockets, concealed chest zip cell pocket on left side
- Fleece-lined collar with chin guard
- 2 radiophone clip straps
- Embroidery access zipper
- Full front 2-way zipper with snap placket
- Ribbed elastic waist
- Elastic wrists with hook and loop closure
- 5400H/5401H hood (sold separately)



PROD. NO.	MOD. NO.	Colour	Sizes
V1200250	5400	Hi-Viz Orange	S-4XL
V1200260	5401	Hi-Viz Yellow/Green	XS-4XL



Hood for Hi-Viz 300D Ripstop Waterproof Safety Jacket

- 300 Denier durable ripstop polyester, PU coated
- Snap closure with drawstring
- Snaps for connecting to 300D ripstop jackets



PROD. NO.	MOD. NO.	Colour	Sizes
V1200350	5400H	Hi-Viz Orange	Fit-All
V1200360	5401H	Hi-Viz Yellow/Green	Fit-All



300D Hi-Viz Ripstop Waterproof Safety Bib Pant

- 300 Denier durable ripstop polyester, PU coated
- 100% waterproof and windproof
- Double-stitched and heat sealed seams
- Abrasion-, puncture- and tear-resistant
- CSA Z96-09 Class 3 Level 2 when worn with CSA Class 2 Level 2 top featuring reflective arm bands
- StarTech™ reflective tape
- Fully lined
- 12" leg zippers with hook and loop plackets and adjustor straps
- Zippered inside bib pocket
- Zippered fly access



PROD. NO.	MOD. NO.	Colour	Sizes
V1200450	5404	Hi-Viz Orange	S-4XL
V1200460	5405	Hi-Viz Yellow/Green	XS-4XL





450D Hi-Viz Nailhead Polyester Waterproof Jacket

- 100% waterproof 450 Denier oxford polyester
- CSA Z96-09 Class 2 Level 2 (becomes Class 3 when worn with hi-viz pant featuring reflective leg bands)
- StarTech™ reflective tape
- Taped and heat sealed seams
- Fully lined
- Full front zipper with storm placket
- 2 large front cargo pockets
- Seamless shoulders
- Multiple front and back vents
- Adjustable wrists
- D8125OH/D8125YH hood, converts to jacket pouch (sold separately)



PROD. NO.	MOD. NO.	Colour	Sizes
V1110950	D81250J	Hi-Viz Orange	XS-5XL
V1110960	D8125YJ	Hi-Viz Yellow/Green	XS-5XL

Hood/Carrying Case for 450D Hi-Viz Nailhead Polyester Waterproof Jacket

- 100% waterproof 450 Denier oxford polyester



PROD. NO.	MOD. NO.	Colour	Sizes
V1111150	D81250H	Hi-Viz Orange	Fit-All
V1111160	D8125YH	Hi-Viz Yellow/Green	Fit-All



450D Hi-Viz Nailhead Polyester Waterproof Bib Pant

- 100% waterproof 450 Denier oxford polyester
- CSA Z96-09 Class 3 Level 2 when worn with CSA Class 2 Level 2 top featuring reflective arm bands
- StarTech™ reflective tape
- Taped and heat sealed seams
- Boot access zippers with adjustable ankles
- Adjustable elastic suspenders with quick-release clips
- Fly access



PROD. NO.	MOD. NO.	Colour	Sizes
V1111050	D81250P	Hi-Viz Orange	XS-5XL
V1111060	D8125YP	Hi-Viz Yellow/Green	XS-5XL





HI-VIZ 3-IN-1 SAFETY RAINWEAR (450D)

450D Hi-Viz 100% Waterproof Bomber

- 450 Denier oxford polyester with PU backing
- CSA Z96-09 Class 2 Level 2 (becomes Class 3 when worn with hi-viz pant featuring reflective leg bands)
- StarTech™ reflective tape
- Inner zipper to accommodate optional 3-in-1 zip-in fleece liner 6924/6925/6925BK (sold separately)
- 100% waterproof and windproof
- Fully mesh lined
- Taped and heat sealed seams
- 2 radiophone clip straps
- Cell phone pocket
- 2 front pockets
- Full front zipper with snap storm placket
- Detachable snap hood
- Adjustable wrists and elastic waist



PROD. NO.	MOD. NO.	Colour	Sizes
V1110150	5574A	Hi-Viz Orange	S-4XL

450D Hi-Viz 100% Waterproof Jacket

- 450 Denier oxford polyester with PU backing
- CSA Z96-09 Class 2 Level 2 (becomes Class 3 when worn with hi-viz pant featuring reflective leg bands)
- StarTech™ reflective tape
- Inner zipper to accommodate optional 3-in-1 zip-in fleece liner 6924/6925/6925BK (sold separately)
- 100% waterproof and windproof
- Fully mesh lined
- Taped and heat sealed seams
- 2 front pockets
- Full front zipper with snap storm placket
- Detachable snap hood
- Storm cuffs



PROD. NO.	MOD. NO.	Colour	Sizes
V1110250	5575A	Hi-Viz Orange	S-4XL
V1110660	5585A	Hi-Viz Yellow/Green	XS-4XL

Optional Hi-Viz Polyester Fleece Hoodie Inner:

- Zips into inner zipper on 5575A/5585A or 5574A to make 3-in-1 jacket (optional, sold separately)
- See page 731 for full details

PROD. NO.	MOD. NO.	Colour	Sizes
V1060350	6924	Hi-Viz Orange	S-5XL
V1060460	6925	Hi-Viz Yellow/Green	XS-5XL
V1060471	6925BK	Black	S-5XL

HI-VIZ 3-IN-1 SAFETY RAINWEAR (450D)



450D Hi-Viz 100% Waterproof Pant

- 450 Denier oxford polyester with PU backing
- CSA Z96-09 Class 3 Level 2 when worn with CSA Class 2 Level 2 top featuring reflective arm bands
- StarTech™ reflective tape
- 100% waterproof and windproof
- Taped and heat sealed seams
- 2 pass-through pockets
- Elastic waist
- Rear pocket



PROD. NO.	MOD. NO.	Colour	Sizes
V1110350	5576	Hi-Viz Orange	S-3XL
V1110360	5586	Hi-Viz Yellow/Green	XS-3XL

450D Hi-Viz 100% Waterproof Bib Pant

- 450 Denier PU coated oxford polyester with PU backing
- CSA Z96-09 Class 3 Level 2 when worn with CSA Class 2 Level 2 top featuring reflective arm bands
- StarTech™ reflective tape
- 100% waterproof and windproof
- Taped and heat sealed seams
- Fully lined
- Inside bib pocket with pen slot
- Boot access zippers with adjustable ankles
- Premium adjustable elastic suspenders
- Zipper fly access



PROD. NO.	MOD. NO.	Colour	Sizes
V1110450	5578	Hi-Viz Orange	S-4XL
V1110460	5588	Hi-Viz Yellow/Green	XS-4XL





HI-VIZ 3-IN-1 SAFETY RAINWEAR (300D)

Faux Fur Lined Waterproof Safety Bomber Jacket

- 5,000 waterproof 300 Denier oxford polyester, PU coated
- CSA Z96-09 Class 2 Level 2 (as long as sleeves are not zipped off, becomes Class 3 when worn with hi-viz pant featuring reflective leg bands)
- StarTech™ reflective tape
- Taped and heat sealed seams
- Removable black faux fur liner and collar
- Zip-off sleeves
- 2 radiophone clip straps
- Detachable hood
- Navy bottom
- 2 lower pockets, 1 inside pocket on lining
- Ribbed elastic waist
- Snap wrists
- Full front zipper with snap placket



PROD. NO.	MOD. NO.	Colour	Sizes
V1122150	5051	Hi-Viz Orange	S-5XL
V1122160	5052	Hi-Viz Yellow/Green	S-5XL



HI-VIZ 6-IN-1 SAFETY RAINWEAR (300D/450D)

Hi-Viz 100% Waterproof 6-in-1 Parka

- 300 Denier PU coated oxford polyester
- 5020BB/5021BB - Inner and outer jackets CSA Z96-09 Class 2 Level 2 (as long as sleeves are not zipped off, becomes Class 3 when worn with hi-viz pant featuring reflective leg bands)
- 5025 - Inner and outer jackets CSA Z96-09 Class 1 Level 2
- Double-stitched StarTech™ reflective tape
- 100% waterproof and windproof
- Taped and heat sealed seams



OUTER JACKET:

- Quilted lining
- Detachable snap hood
- 2 large front cargo pockets
- 2 inner pockets
- Full front zipper with snap storm placket
- 7" side zippers for greater mobility
- Storm cuffs
- Embroidery access zipper

INNER JACKET:

- Quilted lining
- Detachable sleeves
- Comfort collar
- 2 large front cargo pockets
- 2 inner pockets
- Reversible to black

PROD. NO.	MOD. NO.	Colour	Sizes
V1120151	5020BB	Hi-Viz Orange	XS-5XL
V1120161	5021BB	Hi-Viz Yellow/Green	XS-5XL
V1120470	5025	Black	XS-5XL

HI-VIZ 6-IN-1 SAFETY RAINWEAR (300D/450D)



Hi-Viz 100% Waterproof 6-in-1 Bomber

- 300 Denier PU coated oxford polyester
- Inner and outer jackets CSA Z96-09 Class 2 Level 2 (as long as sleeves are not zipped off, becomes Class 3 when worn with hi-viz pant featuring reflective leg bands)
- Double-stitched StarTech™ reflective tape
- 100% waterproof and windproof
- Taped and heat sealed seams



OUTER JACKET:

- Fully mesh lined
- Detachable snap hood
- Adjustable cuffs
- Full front zipper with snap storm placket
- 2 radiophone clip straps
- 2 large front cargo pockets
- 1 cell phone pocket
- 4 inside pockets

INNER JACKET:

- Quilted lining
- Detachable sleeves
- Comfort collar
- 2 large front cargo pockets
- 2 inner pockets
- Reversible to black



PROD. NO.	MOD. NO.	Colour	Sizes
V1120350	5022	Hi-Viz Orange	XS-5XL
V1120360	5023	Hi-Viz Yellow/Green	XS-5XL

Hi-Viz Heavy-Duty 100% Waterproof Quilted Bib Pant

- 450 Denier PU coated heavy-duty oxford polyester with 5.9 oz (200 GSM) warm quilted polyester lining
- CSA Z96-09 Class 2 Level 2 (becomes Class 3 when worn with CSA Class 2 Level 2 top featuring reflective arm bands)
- Double-stitched StarTech™ reflective tape
- 100% waterproof and windproof
- Double-stitched, taped and heat sealed seams
- 2-way zipper with brass snap storm placket
- Double-layer reinforced knees
- Premium adjustable elastic suspenders with quick-release clips
- Elastic waist
- 2 front slash cargo pockets
- Sealed inside chest pocket with pen slot
- Outside chest pocket with flap
- 20" boot access 2-way leg zippers with snap storm covers



PROD. NO.	MOD. NO.	Colour	Sizes
V1120950	5046	Hi-Viz Orange	S-5XL
V1120960	5047	Hi-Viz Yellow/Green	S-5XL

Double-layer reinforced knees





HI-VIZ 6-IN-1 SAFETY RAINWEAR (300D/450D)

Hi-Viz 100% Waterproof Quilted Bib Pant

- 300 Denier PU coated oxford polyester with 5.3 oz (180 GSM) warm quilted polyester lining
- 5040BB/5041BB - CSA Z96-09 Class 2 Level 2 (becomes Class 3 when worn with CSA Class 2 Level 2 top featuring reflective arm bands)
- 5042 - CSA Z96-09 Class 1 Level 2
- Double-stitched StarTech™ reflective tape
- 100% waterproof and windproof
- 20" boot access 2-way leg zippers with snap storm covers
- Double-stitched, taped and heat sealed seams
- 2-way zipper with brass snap storm placket
- Premium adjustable elastic suspenders with quick-release clips
- Elastic waist
- 2 front slash cargo pockets
- Sealed inside chest pocket with pen slot
- Outside chest pocket with flap



PROD. NO.	MOD. NO.	Colour	Sizes
V1120651	5040BB	Hi-Viz Orange	S-5XL
V1120661	5041BB	Hi-Viz Yellow/Green	S-4XL
V1120870	5042	Black	S-5XL



Hi-Viz 100% Waterproof Quilted Pant

- 300 Denier PU coated oxford polyester with 5.3 oz (180 GSM) warm quilted polyester lining
- CSA Z96-09 Class 3 Level 2 when worn with CSA Class 2 Level 2 top featuring reflective arm bands
- Double-stitched StarTech™ reflective tape
- 100% waterproof and windproof
- 20" boot access 2-way leg zippers with snap storm covers
- Double-stitched, taped and heat sealed seams
- Elastic waist with double snap closure
- Zipper fly access
- 2 front slash cargo pockets
- Hammer loop



PROD. NO.	MOD. NO.	Colour	Sizes
V1120850	5043	Hi-Viz Orange	S-5XL
V1120860	5044	Hi-Viz Yellow/Green	S-4XL

HI-VIZ WATERPROOF/BREATHABLE PREMIUM JACKETS AND PANTS



Waterproof/Breathable Premium Hi-Viz Jacket

- Premium 300 Denier oxford polyester
- CSA Z96-09 Class 2 Level 2 (becomes Class 3 when worn with hi-viz pant featuring reflective leg bands)
- Waterproof/breathable 5,000 / 5,000
- Double-stitched StarTech™ reflective tape
- Taped and heat sealed seams
- Waterproof pit zippers
- Detachable, adjustable drawstring hood, folds into collar
- 2 radiophone clip straps
- Laser-welded waterproof zippers on chest and left arm pocket
- 2 large front zip cargo pockets
- Inner placket cell phone pocket
- Inside zip pocket
- Adjustable drawstring waist and hem
- Embroidery access zipper
- YKK 2-way front zipper with snap placket
- Comfort fleece collar and chin guard



PROD. NO.	MOD. NO.	Colour	Sizes
V1130150	5200	Hi-Viz Orange	S-4XL
V1130160	5201	Hi-Viz Yellow/Green	XS-4XL

3-in-1 Waterproof/Breathable Premium Hi-Viz Jacket

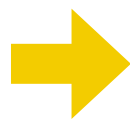

INNER JACKET (included):

- 7 oz (240 GSM) micro fleece
- Reversible zipper front
- 5205/5206 - CSA Z96-09 Class 2 Level 2 (becomes Class 3 when worn with hi-viz pant featuring reflective leg bands)
- 5207 - CSA Z96-09 Class 1 Level 2
- StarTech™ reflective tape
- Elastic wrists with loops for attaching outer jacket
- 2 lower pockets

PROD. NO.	MOD. NO.	Colour	Sizes
V1130250	5205	Hi-Viz Orange	S-4XL
V1130260	5206	Hi-Viz Yellow/Green	XS-4XL
V1130270	5207	Black	S-4XL



HI-VIZ WATERPROOF/BREATHABLE PREMIUM JACKETS AND PANTS



Waterproof/Breathable Premium Hi-Viz Waist Pant

- The most comfortable and full-featured waterproof/breathable safety pant on the market today!
- CSA Z96-09 Class 3 Level 2 when worn with CSA Class 2 Level 2 top featuring reflective arm bands
- Waterproof/breathable 5,000 / 5,000
- Premium 300 Denier PU coated oxford polyester
- StarTech™ reflective tape
- Taped, heat sealed, double-stitched seams
- Covered front zipper with hook and loop closure and snap
- 2-way full-length covered zips for easy on/off
- 1 slash zipper pocket on each side, 1 rear zipper pocket
- Hook and loop adjustor tabs on each side of waist
- Waistband with 7 belt loops and elastic back



PROD. NO.	MOD. NO.	Colour	Sizes
V1130350	5215	Hi-Viz Orange	S-4XL
V1130360	5216	Hi-Viz Yellow/Green	XS-4XL



HI-VIZ WATERPROOF INSULATED JACKETS



100% Waterproof Winter Quilted Safety Parka

- 300 Denier PU coated oxford polyester
- 5030/5031 - CSA Z96-09 Class 2 Level 2 (becomes Class 3 when worn with hi-viz pant featuring reflective leg bands)
- 5031BK - CSA Z96-09 Class 1 Level 2
- StarTech™ reflective tape
- 100% waterproof and windproof
- 5.9 oz (200 GSM) poly filling
- Taped and heat sealed seams
- 2 large front pockets
- Cell/radiophone pocket on left chest
- Inside storage pocket and pouch pocket
- Full front zipper with snap placket
- Embroidery access zipper
- Adjustable hood folds into collar
- Knitted storm cuffs
- Zip-to-top fleece-lined collar



PROD. NO.	MOD. NO.	Colour	Sizes
V1150150	5030	Hi-Viz Orange	S-5XL
V1150160	5031	Hi-Viz Yellow/Green	S-5XL
V1150170	5031BK	Black	S-5XL

100% Waterproof Winter Quilted Safety Bomber

- 300 Denier PU coated oxford polyester
- CSA Z96-09 Class 2 Level 2 (becomes Class 3 when worn with hi-viz pant featuring reflective leg bands)
- StarTech™ reflective tape
- 100% waterproof and windproof
- 5.9 oz (200 GSM) poly filling
- Taped and heat sealed seams
- 2 large front pockets
- Cell/radiophone pocket on left chest
- Inside storage pocket and pouch pocket
- Full front zipper with snap placket
- Embroidery access zipper
- Adjustable hood folds into collar
- Knitted storm cuffs
- Zip-to-top fleece-lined collar



PROD. NO.	MOD. NO.	Colour	Sizes
V1150250	5032	Hi-Viz Orange	S-5XL
V1150260	5033	Hi-Viz Yellow/Green	S-5XL





RAIN SUITS

Tough 210D Oxford Poly/PVC Waterproof Suit

- 2 pieces: hooded jacket and bib pant, fold into zippered storage pouch
- Extra tough 100% waterproof 210 Denier oxford polyester with PVC backing
- CSA Class 1 Level 2
- StarTech™ reflective tape
- Taped and heat sealed seams
- Full back vent for working comfort
- Jacket: 2 lower flap pockets, drawstring with toggle on hem, half mesh lined back, full front zipper, hood folds into collar
- Bib pant: elastic suspenders, metal buckles, snaps on leg hems to snug to boots



PROD. NO.	MOD. NO.	Colour	Sizes
V1080250	5608	Hi-Viz Orange	S-4XL
V1080260	5609	Hi-Viz Yellow/Green	XS-4XL



Tough 150D Hi-Viz Oxford Poly/PVC Waterproof Suit

- 2 pieces: hooded jacket and bib pant, fold into a convenient zippered storage pouch
- Extra tough 100% waterproof 150 Denier hi-viz oxford polyester with PVC backing
- Jacket - CSA Class 2 Level 2 (Class 3 Level 2 when worn with pant)
- StarTech™ reflective tape
- Taped and heat sealed seams
- Liberal fit for working comfort
- Full back vent for breathability
- Peg hangable format
- Jacket: 2 lower flap pockets, drawstring with toggle on hem, half mesh lined back, full front zipper, hood folds into collar
- Bib pant: elastic suspenders, metal buckles, snaps on leg hems to snug to boots



PROD. NO.	MOD. NO.	Colour	Sizes
V1080350	5618	Hi-Viz Orange	S-4XL
V1080360	5619	Hi-Viz Yellow/Green	S-4XL



Lightweight Waterproof Suit

- 2 pieces: hooded jacket and bib pant, fold into storage pouch
- 100% waterproof polyester/PVC
- CSA Z96-09 Class 1 Level 2
- StarTech™ reflective tape
- Taped and heat sealed seams
- Jacket: back vents, adjustable hem, 2 large front cargo pockets
- Hood folds and zips into collar



PROD. NO.	MOD. NO.	Colour	Sizes
V1080150	5598	Orange	S-4XL
V1080160	5599	Yellow/Green	XS-4XL
V1080170	5599BK	Black	XS-4XL



Hi-Viz Breathable Traffic Control Safety Jacket

- 3.5 oz (120 GSM) tricot polyester
- CSA Z96-09 Class 2 Level 2 (becomes Class 3 when worn with hi-viz pant featuring reflective leg bands)
- Meets Transports Québec P4.34.1 (Road Work Signage)
- StarTech™ reflective tape with orange tricot trim in between bands
- Full front zipper with hook and loop placket
- Collar in contrasting colour
- Black cuffs
- Invisible underarm zippers
- Chest pocket with pen slot on right side
- Shoulder and chest radiophone clip strap on each side
- ID pockets



PROD. NO.	MOD. NO.	Colour	Sizes
V1190160	6007	Hi-Viz Yellow/Green	XS-4XL

NEW

Hi-Viz Breathable Traffic Control Safety Pant

- 3.5 oz (120 GSM) tricot polyester
- CSA Z96-09 Class 3 Level 2 when worn with CSA Class 2 Level 2 top featuring reflective arm bands
- Meets Transports Québec P4.34.1 (Road Work Signage)
- StarTech™ reflective tape across knees with orange tricot trim in between bands
- Belt loops
- Hook and loop fly opening and closure on waistband
- 2 cargo pockets on each side
- 2 back pockets with flaps
- 2 slash pockets
- Black hem with hook and loop closure
- Boot access zippers with adjustable ankles



PROD. NO.	MOD. NO.	Colour	Sizes
V1190260	6009	Hi-Viz Yellow/Green	XS-4XL

NEW





QUÉBEC HI-VIZ TRAFFIC RAIN WEAR

Hi-Viz Traffic Control Waterproof Safety Jacket

- 5,000 mm 100% waterproof 300 Denier oxford polyester, PU coated
- CSA Z96-09 Class 2 Level 2 (becomes Class 3 when worn with hi-viz pant featuring reflective leg bands)
- Meets Transports Québec P4.34.1 (Road Work Signage)
- StarTech™ reflective tape with orange trim in between bands
- Taped and heat sealed seams
- Fully mesh lined
- Full front zipper with hook and loop placket
- Collar in contrasting colour
- Black cuffs
- Underarm zippers
- Chest pocket with pen slot on right side
- Shoulder and chest radiophone clip strap on each side
- ID pockets
- Back vent



PROD. NO.	MOD. NO.	Colour	Sizes
V1190360	6037	Hi-Viz Yellow/Green	XS-4XL

NEW

Hi-Viz Traffic Control Waterproof Safety Pant

- 5,000 mm 100% waterproof 300 Denier oxford polyester, PU coated
- CSA Z96-09 Class 3 Level 2 when worn with CSA Class 2 Level 2 top featuring reflective arm bands
- Meets Transports Québec P4.34.1 (Road Work Signage)
- StarTech™ reflective tape across knees with orange trim in between bands
- Taped and heat sealed seams
- Fully mesh lined
- Belt loops
- Hook and loop fly opening and hook closure on waistband
- 2 cargo pockets on each side
- 2 back pockets with flaps
- 2 slash pockets
- Black hem with hook and loop closure
- Boot access zippers with adjustable ankles



PROD. NO.	MOD. NO.	Colour	Sizes
V1190460	6039	Hi-Viz Yellow/Green	XS-4XL

NEW



FLAME RESISTANT WEAR

**SUPERIOR
ARC AND
FLASH FIRE
SAFETY**

755



FR-TECH™

SAFETY UNCOMPROMISED
Highest rated flame resistant apparel to
protect Canadian workers on the job

Superior flame resistance and arc flash protection

NEW FROM PIONEER

FR-Tech™ premium materials have been developed and tested by Pioneer to provide superior flame resistance, flash fire and arc flash protection, and are designed especially for the needs of Canadian workers.

What is a Flash Fire?

CGSB 155.20-2000 defines flash fire as “A rapidly moving flame front which can be a combustion explosion. Flash fire may occur in an environment where fuel and air become mixed in adequate concentrations to combust and where all sources of ignition have not been controlled. Hydrocarbon flash fire has a heat flux of approximately 84 kW/m² for relatively short periods of time, typically three seconds or less.” (CGSB) and “A fire that spreads by means of a flame front rapidly through a diffuse fuel, such as dust, gas, or the vapors of an ignitable liquid, without the production of damaging pressure.” (NFPA) Such conditions are a threat in the petrochemical, chemical, oil and gas industries. Non-FR clothing worn in these industries or related service industries can add to worker injuries by providing further fuel that could ignite in the flash fire to cause further wearer injuries. FR-Tech™ fabrics provide superior protection from flash fire.

What is TPP?

TPP (Thermal Protective Performance): Fabrics are tested with thermal energy to determine the level of energy needed to cause a second-degree burn injury. To pass *CGSB 155.20-2000* standards, a single-layer garment must have a minimum TPP value of 6. The higher the TPP value, the better the protection.

Pioneer FR-Tech™ garments exceed the criteria specified in the *CGSB 155.20-2000* standard for TPP values, both in spacer and contact tests.

ARC/HRC	ATPV
Class 1	Min. 4 cal/cm ²
Class 2	Min. 8 cal/cm ²
Class 3	Min. 25 cal/cm ²
Class 4	Min. 40 cal/cm ²

What are ARC and ATPV?

ARC (Arc Rated Category) is a rating indicating the electric arc resistance

of a garment. The material is tested to determine the *ATPV (Arc Thermal Protective Value)*, which is the incident energy on a material or several layers of material resulting in a 50% chance of sufficient heat passing through said material(s) to cause a second-degree burn. The chart above shows the ATPV level required for each ARC class level.

Other FR Standards:

ASTM F1506-10a – Standard Performance Specification for Textile Material for Wearing Apparel for Use by Electrical Workers exposed to Momentary Electric Arc and Related Thermal Hazards. Testing includes flame resistance (25 washes), arc rating, tear resistance, breaking strength, seam slippage, colourfastness, and laundering shrinkage.

The *ASTM 1506-10a* standard is referenced by the Canadian Electric Arc Standard *CSA Z462-15* and by *NFPA 70E-2015*. By passing the tests specified in the *ASTM 1506-10a* standard criteria, Pioneer FR-Tech™ garments meet *CSA Z462-15* and *NFPA-70E* arc requirements.

NFPA 2112 – 2012 Standard on Flame Resistant Garments for Protection of Industrial Personnel Against Flash Fire. Specifies the minimum design, performance, certification and testing requirements for flame-resistant fabric and garments for use in areas at risk from flash fires. Testing includes flame resistance (100 washes), heat transfer performance, heat resistance, thermal shrinkage, flash fire resistance (tested on manikin according to protocols specified in *ASTM 1930-13*), tensile strength, tearing strength, laundering shrinkage and colour fastness.

Features include:

- FR woven blend of 88% premium cotton and 12% high-tenacity nylon
- Combines the softness, breathability and comfort of cotton with the durability, strength and abrasion resistance of nylon
- Retains strength, FR and arc flash properties even after more than 100 washes
- Tested in independent Canadian labs to meet Canadian and international flame resistance and arc flash standards
- Flame resistance guaranteed for the life of the garment
- All componentry including zippers, reflective tape, thread and fasteners tested to FR standards
- Suitable for industrial wash

Understanding FR Standard

CGSB 155.20-2000

CGSB 155.20-2000 – Workwear for Protection Against Hydrocarbon Flash Fire. States the minimum requirements for performance of workwear worn for protection against unplanned exposure to hydrocarbon flash fire. Testing includes flame resistance (fabrics tested before and after wash/dry cycles), Thermal Protective Performance (TPP), heat resistance, and thermal shrinkage resistance. All components of the garments must meet required *CGSB 155.20-2000* standards, not only the outer shell material.

The standard categorizes FR garments into 3 different types:

TYPE 1 – Single-Layer

Pioneer example:

7700 88/12 COVERALL

Protective garment constructed from a single fabric.

Requirements include flame resistance before and after 50 washes, Thermal Protective Performance value of 6 or greater, heat resistance to 260°C, and thermal shrinkage of no more than 10%.

TYPE 2 – Multi-Layer

Pioneer example:

5523 WINTER PARKA

Protective garment consisting of outer shell fabric and inner lining fabric, and/or insulation material.

Requirements include flame resistance before and after washing, Thermal Protective Performance (TPP) value of 5 or greater, heat resistance to 260°C, and thermal shrinkage of no more than 10%.

TYPE 3 – Disposable

Pioneer example:

578 RAIN SUIT

Must meet flame resistance criteria before washing and should be worn over another approved FR garment. Exempt from all other requirements.

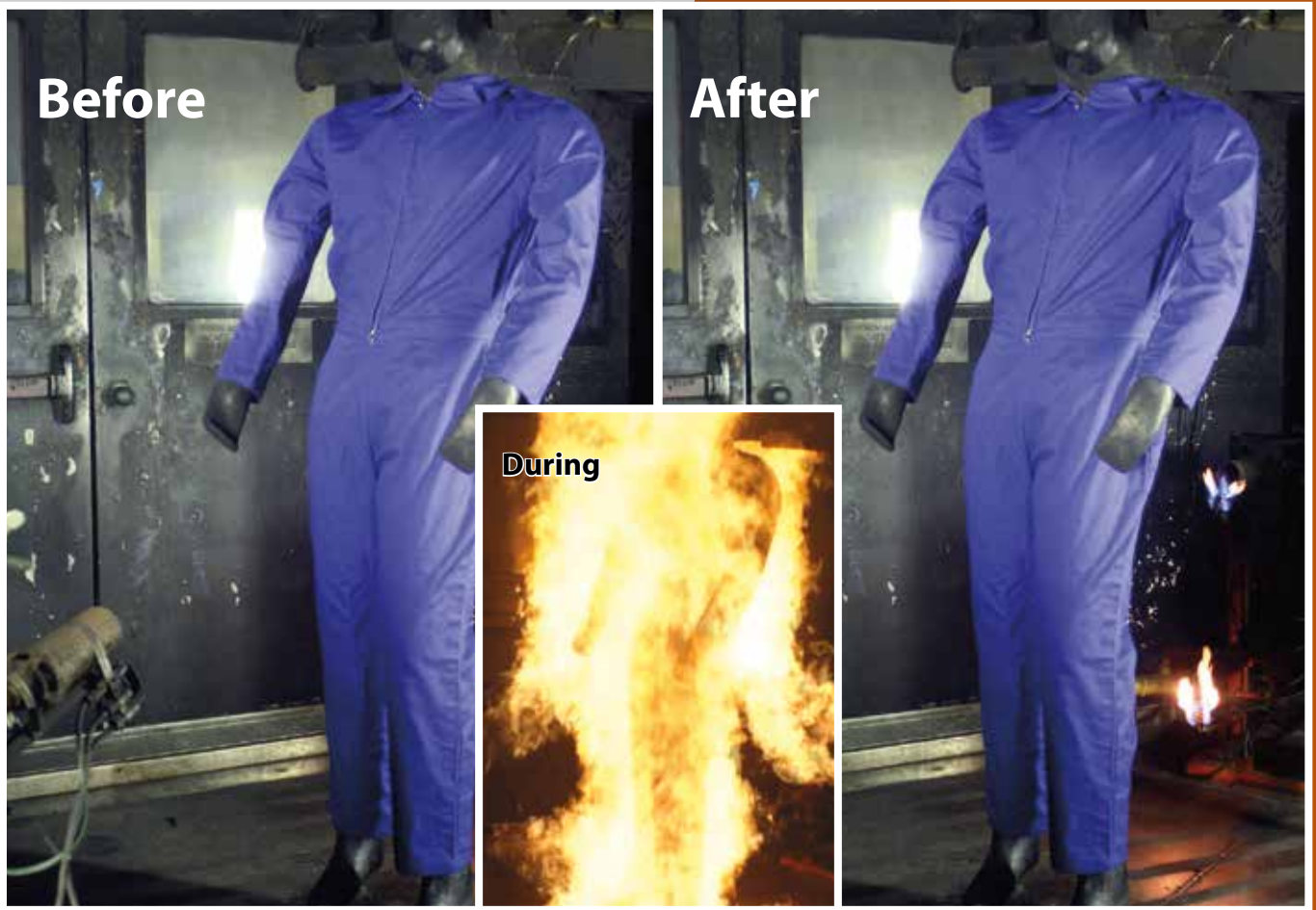

FR-Tech™ Outstanding Test Results

FLASH FIRE TESTING

N.C.S.U. PYROMAN™

Testing Protocol:

- Independent university laboratory testing
- Adherence to ASTM F1930-13 (Standard Test Method for Evaluation of Flame Resistant Clothing for Protection Against Fire Simulations Using an Instrumented Manikin)
- Identically styled regular coveralls (size 42)
- All coveralls tested over 100% cotton t-shirts and briefs
- Coveralls must test to less than 50% bodily burn to pass

TEST TYPE:

Flash fire simulation on 10 oz FR-Tech™ coveralls

Exposure time:

- 3.0 seconds

Measurement time:

- 60.0 seconds

Second-degree burn average:

- 0.82%

Third-degree burn average:

- 6.284%

Total burn average:

- 7.11%

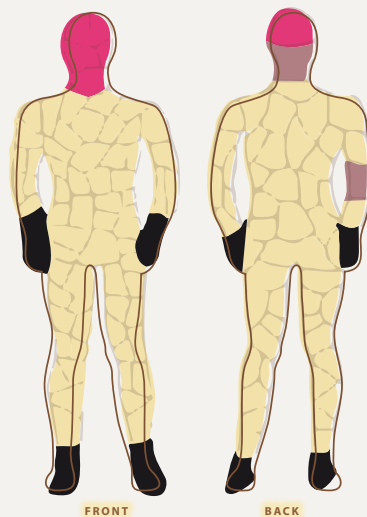

*Note that the 6.284% third-degree burn test result is entirely in the head area which is not protected by coverall. Hands and feet are excluded from this testing protocol.

- INVALID SENSOR
- NO BURN
- 2ND DEGREE BURN
- 3RD DEGREE BURN

Compare these superior test results with those of all other brands. Be extra-safe with Pioneer FR-Tech™ product!

PREMIUM FULL-FEATURED

88/12

FLAME/ARC-RESISTANT GEAR



SAFETY UNCOMPROMISED
Highest rated flame resistant apparel to
protect Canadian workers on the job



FR-Tech™ 88% premium cotton blended with
12% high-tenacity nylon, 10 oz (340 GSM)

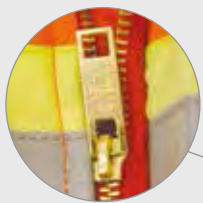

2-way FR
brass zipper



Sewn with inherently
FR thread

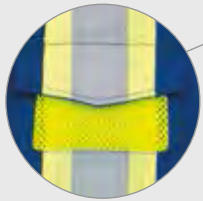

Gas detection mesh
front pocket



ATPV 14 cal/cm²
(Arc Thermal
Protective Value)



Double-stitched 4"
StarTech™ FR Protex®
contrast bands

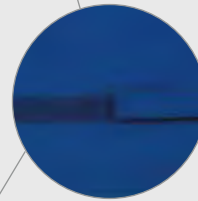

Adjustable wrists
and ankles

FLAME RESISTANT SAFETY COVERALL

- FR-Tech™ 88% premium cotton blended with 12% high-tenacity nylon, 10 oz (340 GSM)
- Material and all components meet CGSB 155.20, 2000
- Thermal Protective Performance (TPP) value: with the spacer 9.4 / contact test 5.8
- CSA Z96-09 Class 1 Level 2 and Class 1 Level FR
- Meets ASTM F1506-10a, NFPA 70E and CSA Z462-15
- Meets NFPA 2112-2012
- ATPV 14 cal/cm² (Arc Thermal Protective Value)
- ARC 2 Arc Rating Category (HRC 2)
- Flame resistance guaranteed for the life of the garment
- Suitable for industrial wash
- Radiophone clip strap
- 7 storage pockets: 2 back, 2 chest, 2 side, 1 tool
- 2 pass-through pockets
- Action back and elastic waist
- Sizes: 36-66
- Tall Sizes: 40-66

OVERALLS ALSO AVAILABLE:

- Royal #7710 (V2540280)
- Orange #7711 (V2540250)

#7700 (V2540180)
and/or
#7700T (V254018T)

#7701 (V254015T)
and/or
#7701T (V254015T)

ARC 2 Arc Rating
Category (HRC 2)



CSA Z96-09 Class 1 Level 2 and Class 1 Level FR

FR-Tech™ Flame Resistant Safety Coverall

- FR-Tech™ 88% premium cotton blended with 12% high-tenacity nylon, 10 oz (340 GSM)
- Material and all components meet CGSB 155.20, 2000
- Thermal Protective Performance (TPP) value: with the spacer 9.4 / contact test 5.8
- CSA Z96-09 Class 1 Level 2 and Class 1 Level FR
- Meets ASTM F1506-10a, NFPA 70E and CSA Z462-15
- Meets NFPA 2112-2012
- ATPV 14 cal/cm² (Arc Thermal Protective Value)
- ARC 2 Arc Rating Category (HRC 2)
- Double-stitched StarTech™ FR reflective tape, Protex® hi-viz reflective trim
- Sewn with inherently FR thread
- Flame resistance guaranteed for the life of the garment
- Suitable for industrial wash • Radiophone clip strap
- Gas detection mesh front pocket • 2-way FR brass zipper
- 7 storage pockets: 2 back, 2 chest, 2 side, 1 tool • 2 pass-through pockets
- Adjustable wrists and ankles • Action back and elastic waist



PROD. NO.	MOD. NO.	Colour	Sizes
V2540180	7700	Royal	36-66
V254018T	7700T	Royal	40T-66T
V2540150	7701	Orange	36-66
V254015T	7701T	Orange	40T-66T



FR-Tech™ Flame Resistant Safety Overall

- FR-Tech™ 88% premium cotton blended with 12% high-tenacity nylon, 10 oz (340 GSM)
- Material and all components meet CGSB 155.20, 2000
- Thermal Protective Performance (TPP) value: with the spacer 9.4 / contact test 5.8
- CSA Z96-09 Class 1 Level 2 and Class 1 Level FR — should be worn with an approved FR long-sleeved garment
- Meets ASTM F1506-10a, NFPA 70E and CSA Z462-15
- Meets NFPA 2112-2012
- ATPV 14 cal/cm² (Arc Thermal Protective Value)
- ARC 2 Arc Rating Category (HRC 2)
- Double-stitched StarTech™ FR reflective tape, Protex® hi-viz reflective trim
- Sewn with inherently FR thread
- Flame resistance guaranteed for the life of the garment
- Suitable for industrial wash • Radiophone clip strap
- Gas detection mesh front pocket • 2-way FR brass zipper
- Adjustable elastic suspenders • 7 storage pockets: 2 back, 2 chest, 2 side, 1 tool
- 2 pass-through pockets



PROD. NO.	MOD. NO.	Colour	Sizes
V2540280	7710	Royal	S-5XL
V2540250	7711	Orange	S-5XL





FR-TECH™ 88/12 SAFETY WEAR



Vented back

Pit zips

FR-Tech™ Flame Resistant 7 oz Safety Coverall

- FR-Tech™ 88% premium cotton blended with 12% high-tenacity nylon, 7 oz (240 GSM)
- Material and all components meet CGSB 155.20, 2000
- Thermal Protective Performance (TPP) value: with the spacer 7.4 / contact test 6.3
- CSA Z96-09 Class 1 Level 2 and Class 1 Level FR
- Meets ASTM F1506-10a, NFPA 70E and CSA Z462-15
- Meets NFPA 2112-2012
- ATPV 8.9 cal/cm² (Arc Thermal Protective Value)
- ARC 2 Arc Rating Category (HRC 2)
- Double-stitched StarTech™ FR reflective tape, Protex® hi-viz reflective trim
- Sewn with inherently FR thread
- Flame resistance guaranteed for the life of the garment
- Vented arms and back with FR zipper closure and hook and loop closure
- Suitable for industrial wash
- Radiophone clip strap
- Gas detection mesh front pocket
- 2-way FR brass zipper
- 7 storage pockets: 2 back, 2 chest, 2 side, 1 tool • 2 pass-through pockets
- Adjustable wrists and ankles • Action back and elastic waist



PROD. NO.	MOD. NO.	Colour	Sizes
V2540680	7720	Royal	36-66
V254068T	7720T	Royal	40T-60T
V2540650	7721	Orange	36-66
V2540650T	7721T	Orange	40T-60T



FR-Tech™ Flame Resistant Surveyor's Vest

- Flame resistance and comfort combined
- FR-Tech™ 88% premium cotton blended with 12% high-tenacity nylon, 10 oz (340 GSM)
- Material and all components meet CGSB 155.20, 2000 — must be worn with an FR/arc rated sleeved garment
- Thermal Protective Performance (TPP) value: with the spacer 9.4 / contact test 5.8
- CSA Z96-09 Class 1 Level 2 and Class 1 Level FR
- Meets ASTM F1506-10a, NFPA 70E and CSA Z462-15
- StarTech™ FR reflective tape, Protex® hi-viz reflective trim
- ATPV 14 cal/cm² (Arc Thermal Protective Value)
- ARC 2 Arc Rating Category (HRC 2)
- Flame resistance guaranteed for the life of the garment
- Suitable for industrial wash
- Metal snap front, radiophone clip strap and pocket
- Multiple front pockets including cell phone pockets, 4 inner pockets, big back pouch with zipper opening
- D-ring access slot and hanger loop
- Reinforced shoulder seam, herringbone contrast binding



PROD. NO.	MOD. NO.	Colour	Sizes
V2540340	7734	Red	S-4XL
V2540370	7735	Black	S-4XL
V2540380	7736	Royal	S-4XL



FR-Tech™ Flame Resistant 7 oz Work Shirt

- FR-Tech™ 88% premium cotton blended with 12% high-tenacity nylon, 7 oz (240 GSM)
- Material and all components meet CGSB 155.20, 2000
- Thermal Protective Performance (TPP) value: with the spacer 7.4 / contact test 6.3
- 7743 - CSA Z96-09 Class 1 Level 2 and Class 1 Level FR
- Meets ASTM F1506-10a, NFPA 70E and CSA Z462-15
- Meets NFPA 2112-2012
- ATPV 8.9 cal/cm² (Arc Thermal Protective Value)
- ARC 2 Arc Rating Category (HRC 2)
- 7743 - Double-stitched StarTech™ FR reflective tape, Protex® hi-viz reflective trim
- Sewn with inherently FR thread
- Flame resistance guaranteed for the life of the garment
- Suitable for industrial wash
- Non-conductive FR buttons • 2 patch pockets with flap



PROD. NO.	MOD. NO.	Colour	Sizes
V2540430	7741	Light Blue	S-4XL
V2540440	7742	Navy	S-4XL
V2540450	7743	Navy	S-4XL



FR-Tech™ Flame Resistant 7 oz Work Pant

- FR-Tech™ 88% premium cotton blended with 12% high-tenacity nylon, 7 oz (240 GSM)
- Material and all components meet CGSB 155.20, 2000
- Thermal Protective Performance (TPP) value: with the spacer 7.4 / contact test 6.3
- Meets ASTM F1506-10a, NFPA 70E and CSA Z462-15
- Meets NFPA 2112-2012
- ATPV 8.9 cal/cm² (Arc Thermal Protective Value)
- ARC 2 Arc Rating Category (HRC 2)
- 7763 - Double-stitched StarTech™ FR reflective tape, Protex® hi-viz reflective trim
- Sewn with inherently FR thread
- Flame resistance guaranteed for the life of the garment
- Suitable for industrial wash
- Non-conductive FR buttons
- FR brass zipper • 4 pockets: 2 front, 2 back
- 7762/7763 - 2 cargo utility pockets with flaps



PROD. NO.	MOD. NO.	Colour	Sizes
V2540530	7761	Navy	See chart below
V2540540	7762	Navy	See chart below
V2540550	7763	Navy	See chart below



		Width										
		30	32	34	36	38	40	42	44	46	48	50
Length	30											
	32											
	34											



FR SAFETY VESTS

100% Cotton Flame Resistant Safety Vest

- 100% FR treated preshrunk cotton knit
- Material and all components meet CGSB 155.20, 2000 — must be worn with an FR/arc rated sleeved garment
- Thermal Protective Performance (TPP) value: with the spacer 7.5 / contact test 5.9
- CSA Z96-09 Class 1 Level 2 and Class 1 Level FR
- Meets ASTM F1506-10a, NFPA 70E and CSA Z462-15
- ATPV 9 cal/cm² (Arc Thermal Protective Value)
- ARC 2 Arc Rating Category (HRC 2)
- StarTech™ FR reflective tape
- Sewn with inherently FR thread
- Cell phone pocket
- Snap front
- D ring access slot



PROD. NO.	MOD. NO.	Colour	Sizes
V2510150	128	Orange	XS-5XL
V2510170	129	Black	XS-5XL



Flame Resistant Hi-Viz Vest

- FR treated polyester mesh
- Meets EN ISO 14116 Index 1
- Must be worn over an FR sleeved garment
- CSA Z96-09 Class 2 Level 2
- 5 point tear-away
- StarTech™ FR reflective tape
- D ring access slot
- Adjustable 1 size up at front



PROD. NO.	MOD. NO.	Colour	Sizes
V2510850	6914A	Hi-Viz Orange	S/M, L/XL, 2/3XL, 4/5XL
V2510860	6916A	Hi-Viz Yellow/Green	S/M, L/XL, 2/3XL, 4/5XL



Flame Resistant Cotton Duck Quilted Vest

- 100% FR treated preshrunk 10 oz (350 GSM) cotton duck
- 5.3 oz (180 GSM) modacrylic FR insulation
- Shell material meets CGSB 155.20, 2000 — must be worn with an FR/arc rated sleeved garment
- Thermal Protective Performance (TPP) value of shell fabric: with the spacer 10.4 / contact test 8.3
- CSA Z96-09 Class 1 Level 2 and Class 1 Level FR
- Meets ASTM F1506-10a, NFPA 70E and CSA Z462-15
- ATPV 12 cal/cm² (Arc Thermal Protective Value) (shell fabric only)
- ARC 2 Arc Rating Category (HRC 2)
- StarTech™ FR reflective tape
- Sewn with inherently FR thread
- 5 storage pockets: 2 front slash, 3 inner
- Full brass zipper



PROD. NO.	MOD. NO.	Colour	Sizes
V2510370	1375F	Black	S-3XL

Flame Resistant 100% Cotton Unlined Vest

- 100% FR treated preshrunk 10 oz (350 GSM) cotton duck
- Material and all components meet CGSB 155.20, 2000 — must be worn with an FR/arc rated sleeved garment
- Thermal Protective Performance (TPP) value: with the spacer 10.4 / contact test 8.3
- CSA Z96-09 Class 1 Level 2 and Class 1 Level FR
- Meets ASTM F1506-10a, NFPA 70E and CSA Z462-15
- ATPV 12 cal/cm² (Arc Thermal Protective Value)
- ARC 2 Arc Rating Category (HRC 2)
- StarTech™ FR reflective tape
- Sewn with inherently FR thread
- Double snap adjustable front
- 5 storage pockets: 2 front, 2 inner, 1 cell phone
- 2 radiophone clip straps
- D ring access slot
- 3 pen slots



PROD. NO.	MOD. NO.	Colour	Sizes
V2510470	1385F	Black	S-4XL

Flame Resistant Modacrylic Mesh Vest

- 100% FR 3 oz (110 GSM) modacrylic mesh
- Meets CGSB 155.20, 2000 for Type 3 garments — must be worn with an FR sleeved garment
- CSA Z96-09 Class 1 Level 2 and Class 1 Level FR
- StarTech™ FR reflective tape
- Sewn with inherently FR thread
- 5 point tear-away
- FR hook and loop front closure
- D ring access slot



PROD. NO.	MOD. NO.	Colour	Sizes
V2510750	6911	Hi-Viz Orange	S/M, L/XL, 2/3XL, 4/5XL
V2510760	6917	Hi-Viz Yellow/Green	S/M, L/XL, 2/3XL, 4/5XL





FR SINGLE-LAYER SAFETY WEAR

Flame Resistant Cotton Safety Jacket

- 100% cotton, FR treated, 10 oz (340 GSM)
- Material and all components meet CGSB 155.20, 2000
- Thermal Protective Performance (TPP) value: with the spacer 11 / contact test 8.2
- CSA Z96-09 Class 1 Level 2 and Class 1 Level FR
- Meets ASTM F1506-10a, NFPA 70E and CSA Z462-15
- ATPV 9.5 cal/cm² (Arc Thermal Protective Value)
- ARC 2 Arc Rating Category (HRC 2)
- StarTech™ FR reflective tape
- Sewn with inherently FR thread
- Brass FR non-locking zipper plus snap storm placket
- 4 storage pockets: 2 chest, 2 front
- Radiophone clip strap



PROD. NO.	MOD. NO.	Colour	Sizes
V2550110	5554	Royal	S-5XL
V2550150	5553	Orange	S-5XL



Flame Resistant Cotton Safety Overall

- 100% cotton, FR treated, 10 oz (340 GSM)
- Material and all components meet CGSB 155.20, 2000
- Thermal Protective Performance (TPP) value: with the spacer 11 / contact test 8.2
- CSA Z96-09 Class 1 Level 2 and Class 1 Level FR
- Meets ASTM F1506-10a, NFPA 70E and CSA Z462-15
- ATPV 9.5 cal/cm² (Arc Thermal Protective Value)
- ARC 2 Arc Rating Category (HRC 2)
- StarTech™ FR reflective tape
- Sewn with inherently FR thread
- 2-way brass FR non-locking zipper
- Adjustable elastic suspenders
- 7 storage pockets: 2 back, 2 chest, 2 side, 1 ruler
- 2 pass-through pockets
- Radiophone clip strap



PROD. NO.	MOD. NO.	Colour	Sizes
V2550210	5566	Royal	S-5XL
V2550250	5573	Orange	S-5XL

Flame Resistant Cotton Coverall

- 100% cotton, FR treated, 10 oz (340 GSM)
- Meets CGSB 155.20, 2000
- Thermal Protective Performance (TPP) value: with the spacer 11 / contact test 8.2
- Meets ASTM F1506-10a, NFPA 70E and CSA Z462-15
- ATPV 9.5 cal/cm² (Arc Thermal Protective Value)
- ARC 2 Arc Rating Category (HRC 2)
- Sewn with inherently FR thread
- 2-way brass zipper
- 7 storage pockets: 2 back, 2 chest, 2 side, 1 tool
- Pass-through pocket on right side
- Action back and elastic waist
- Adjustable wrists and ankles



PROD. NO.	MOD. NO.	Colour	Sizes
V2520310	5559	Royal	36-60
V252031T	5559T	Royal	40T-60T

Flame Resistant Cotton Safety Coverall

- 100% cotton, FR treated, 10 oz (340 GSM)
- Material and all components meet CGSB 155.20, 2000
- Thermal Protective Performance (TPP) value: with the spacer 11 / contact test 8.2
- CSA Z96-09 Class 1 Level 2 and Class 1 Level FR
- Meets ASTM F1506-10a, NFPA 70E and CSA Z462-15
- ATPV 9.5 cal/cm² (Arc Thermal Protective Value)
- ARC 2 Arc Rating Category (HRC 2)
- StarTech™ FR reflective tape
- Sewn with inherently FR thread
- 2-way FR brass non-locking zipper
- 7 storage pockets: 2 back, 2 chest, 2 side, 1 tool
- 2 pass-through pockets
- Adjustable wrists and ankles
- Action back and elastic waist
- Radiophone clip strap



PROD. NO.	MOD. NO.	Colour	Sizes
V2520210	5558A	Royal	36-66
V252021T	5558AT	Royal	40T-66T
V2520250	5555	Orange	36-66
V252025T	5555T	Orange	40T-66T
V2520270	5558BK	Black	36-66
V252027T	5558BKT	Black	40T-66T



FR SINGLE-LAYER SAFETY WEAR

Women's Flame Resistant Cotton Safety Coverall

- 100% cotton, FR treated, 10 oz (340 GSM)
- Meets CGSB 155.20, 2000
- Thermal Protective Performance (TPP) value: with the spacer 11 / contact test 8.2
- CSA Z96-09 Class 1 Level 2 and Class 1 Level FR
- Meets ASTM F1506-10a, NFPA 70E and CSA Z462-15
- ATPV 9.5 cal/cm² (Arc Thermal Protective Value)
- ARC 2 Arc Rating Category (HRC 2)
- StarTech™ FR reflective tape
- Sewn with inherently FR thread
- Full 2-way YKK brass zips from waist to ankle
- Unique zip design for convenient washroom access
- 8 storage pockets: 2 back, 2 chest, 2 side, 1 ruler, 1 sealed inside left chest pocket
- Action back and elastic waist
- Adjustable wrists and ankles
- Radiophone clip strap



Unique zip design for convenient washroom access



PROD. NO.	MOD. NO.	Colour	Sizes
V2520970	5558BW	Black	Women's XS-2XL

FR MULTI-LAYER SAFETY WEAR

Flame Resistant Quilted Cotton Safety Overall

- Shell fabric 100% cotton, FR treated
- 5.3 oz (180 GSM) modacrylic FR insulation
- Material and all components meet CGSB 155.20, 2000
- Thermal Protective Performance (TPP) value: contact test 18.8
- CSA Z96-09 Class 1 Level 2 and Class 1 Level FR
- Meets ASTM F1506-10a, NFPA 70E and CSA Z462-15
- ATPV 46 cal/cm² (Arc Thermal Protective Value)
- ARC 4 Arc Rating Category (HRC 4)
- All metal components are concealed to ensure no arc flash conductivity
- StarTech™ FR reflective tape
- Sewn with inherently FR thread
- 2-way FR brass non-locking zipper with storm placket
- Tough double-stitched seams
- 7 storage pockets: 2 back, 2 chest, 2 side, 1 tool
- Adjustable elastic suspenders and elastic waist
- 3/4 zipper plus snaps on each side
- Hammer loop



PROD. NO.	MOD. NO.	Colour	Sizes
V2560311	5524A	Royal	S-5XL
V2560351	5534A	Orange	S-4XL
V2560370	5524BK	Black	S-5XL

Flame Resistant Quilted Cotton Safety Parka

- Shell fabric 100% cotton, FR treated
- 6.5 oz (220 GSM) modacrylic FR insulation
- Material and all components meet CGSB 155.20, 2000
- Thermal Protective Performance (TPP) value: contact test 18.8
- CSA Z96-09 Class 1 Level 2 and Class 1 Level FR
- Meets ASTM F1506-10a, NFPA 70E and CSA Z462-15
- ATPV 46 cal/cm² (Arc Thermal Protective Value)
- ARC 4 Arc Rating Category (HRC 4)
- All metal components are concealed to ensure no arc flash conductivity
- StarTech™ FR reflective tape
- Sewn with inherently FR thread
- FR brass non-locking zipper
- Tough double-stitched seams
- Fleece hand warmers
- Underarm gussets for extra mobility
- 6 storage pockets: 2 back, 2 chest, 2 side
- Action back, elastic waist and aramid storm cuffs
- Radiophone clip strap
- Concealed metal snaps
- 523/524/523BK hood (sold separately)



See page 768
for hoods.

PROD. NO.	MOD. NO.	Colour	Sizes
V2560210	5523	Royal	S-5XL
V2560250	5533	Orange	S-5XL
V2560271	5523BKA	Black	S-5XL

Flame Resistant Quilted Cotton Safety Coverall

- Shell fabric 100% cotton, FR treated
- 6.5 oz (220 GSM) modacrylic FR insulation
- Material and all components meet CGSB 155.20, 2000
- Thermal Protective Performance (TPP) value: contact test 18.8
- CSA Z96-09 Class 1 Level 2 and Class 1 Level FR
- Meets ASTM F1506-10a, NFPA 70E and CSA Z462-15
- ATPV 46 cal/cm² (Arc Thermal Protective Value)
- ARC 4 Arc Rating Category (HRC 4)
- All metal components are concealed to ensure no arc flash conductivity
- StarTech™ FR reflective tape
- Sewn with inherently FR thread
- 2-way FR brass non-locking zipper
- Tough double-stitched seams
- 6 storage pockets: 2 back, 2 chest, 2 side
- Action back, elastic waist and aramid storm cuffs
- Adjustable ankles
- 3/4 zipper plus snaps on each side
- Radiophone clip strap
- Concealed metal snaps
- 523/524/523BK hood (sold separately)



PROD. NO.	MOD. NO.	Colour	Sizes
V2560111	5522A	Royal	S-4XL
V2560151	5532A	Orange	S-4XL
V2560170	5522BK	Black	S-4XL



FR MULTI-LAYER SAFETY WEAR

Hood for Flame Resistant Quilted Cotton Safety Parka or Coverall

- Shell fabric 100% cotton, FR treated
- Meets CGSB 155.20, 2000
- Sewn with inherently FR thread
- FR drawstring with toggle
- Large hook and loop closure
- Concealed metal snap
- Snaps onto parka or coverall



PROD. NO.	MOD. NO.	Colour	Sizes
V2561140	523A	Royal	Fit-All
V2561150	524	Orange	Fit-All
V2561170	523BK	Black	Fit-All



FR HOODIES AND PULLOVERS

Flame Resistant Modacrylic Fleece Hoodie

- Flame resistance and comfort combined
- Modacrylic blend fleece material meets CGSB 155.20, 2000
- Antistatic
- 474 - CSA Z96-09 Class 1 level 2
- ATPV (or EBT) testing in process
- 474 - StarTech™ FR reflective tape
- FR metal zipper front with placket
- Removable snap on/off drawstring hood
- 2 pockets
- Rib cuffs and hem
- Sewn with inherently FR thread



PROD. NO.	MOD. NO.	Colour	Sizes
V2590280	473	Black	XS-5XL
V2590380	474	Black	XS-5XL



Flame Resistant Zip Style Heavyweight Cotton Safety Hoodie

- 100% FR treated preshrunk cotton, 12 oz (400 GSM)
- Material and all components meet CGSB 155.20, 2000
- Thermal Protective Performance (TPP) value: with the spacer 12 / contact test 10.5
- CSA Z96-09 Class 1 Level 2 and Class 1 Level FR
- Meets ASTM F1506-10a, NFPA 70E and CSA Z462-15
- ATPV 23 cal/cm² (Arc Thermal Protective Value)
- ARC 2 Arc Rating Category (HRC 2)
- StarTech™ FR reflective tape
- Sewn with inherently FR thread
- 2 front slash pockets
- FR brass non-locking zipper
- Tough double-stitched seams
- Liberal sizing
- Detachable snap hood



PROD. NO.	MOD. NO.	Colour	Sizes
V2570470	337SF	Black	XS-7XL
V2570450	338SF	Orange	XS-7XL



Flame Resistant Pullover Style Heavyweight Cotton Hoodie

- 100% FR treated preshrunk cotton, 12 oz (400 GSM)
- Material and all components meet CGSB 155.20, 2000
- Thermal Protective Performance (TPP) value: with the spacer 12 / contact test 10.5
- Meets ASTM F1506-10a, NFPA 70E and CSA Z462-15
- ATPV 23 cal/cm² (Arc Thermal Protective Value)
- ARC 2 Arc Rating Category (HRC 2)
- Sewn with inherently FR thread
- Liberal sizing
- Tough double-stitched seams
- Front pouch pocket
- Non-detachable hood



PROD. NO.	MOD. NO.	Colour	Sizes
V2570170	335	Black	XS-7XL



Flame Resistant Zip Style Heavyweight Cotton Hoodie

- 100% FR treated preshrunk cotton, 12 oz (400 GSM)
- Material and all components meet CGSB 155.20, 2000
- Thermal Protective Performance (TPP) value: with the spacer 12 / contact test 10.5
- Meets ASTM F1506-10a, NFPA 70E and CSA Z462-15
- ATPV 23 cal/cm² (Arc Thermal Protective Value)
- ARC 2 Arc Rating Category (HRC 2)
- Sewn with inherently FR thread
- 2 front slash pockets
- FR brass non-locking zipper
- Tough double-stitched seams
- Liberal sizing
- Detachable snap hood



PROD. NO.	MOD. NO.	Colour	Sizes
V2570270	337	Black	XS-7XL



Flame Resistant 1/4 Zip Cotton Pullover

- 100% FR treated preshrunk cotton, 12 oz (400 GSM)
- Material and all components meet CGSB 155.20, 2000
- Thermal Protective Performance (TPP) value: with the spacer 12 / contact test 10.5
- 334SF - CSA Z96-09 Class 1 Level 2 and Class 1 Level FR
- Meets ASTM F1506-10a, NFPA 70E and CSA Z462-15
- ATPV 23 cal/cm² (Arc Thermal Protective Value)
- ARC 2 Arc Rating Category (HRC 2)
- 334SF - Double-stitched StarTech™ FR reflective tape
- Sewn with inherently FR thread
- Standup collar with FR 1/4 zip
- Elastic rib cuffs and hem
- Front pouch pocket



PROD. NO.	MOD. NO.	Colour	Sizes
V2570570	334	Black	XS-5XL
V2570670	334SF	Black	XS-5XL



334

334SF



356

359

FR FLEECE PANTS

Flame Resistant Cotton Fleece Pant

- Flame resistance and comfort combined
- 100% FR treated preshrunk cotton
- Material and all components meet CGSB 155.20, 2000
- Thermal Protective Performance (TPP) value: with the spacer 12 / contact test 10.5
- 359 - CSA Z96-09 Class 3 Level 2 and Class 3 Level FR when worn with Class 2 Level 2 and Class 2 Level FR top featuring reflective arm bands
- Meets ASTM F1506-10a, NFPA 70E and CSA Z462-15
- ATPV 23 cal/cm² (Arc Thermal Protective Value)
- ARC 2 Arc Rating Category (HRC 2)
- 359 - StarTech™ FR reflective tape
- Elastic drawstring waist
- Comfort fit
- 2 front pockets, 1 back pocket



PROD. NO.	MOD. NO.	Colour	Sizes
V2570870	356	Black	S-4XL
V2570970	359	Black	S-4XL



FR UNDERWEAR

Flame Resistant Modacrylic Underwear Set

- Flame resistance and comfort combined
- Modacrylic blend jersey knit
- Antistatic
- ATPV (or EBT) testing in process
- 4401 - Crew neck
- 4402 - Rib cuffs and ankles



4401

4402

PROD. NO.	MOD. NO.	Colour	Sizes
V2591470	4401	Heather Grey	XS-4XL
V2592470	4402	Heather Grey	XS-4XL



Flame Resistant Long-Sleeved Cotton Shirt

- 100% FR treated preshrunk cotton knit, 7.5 oz (250 GSM)
- Material and all components meet CGSB 155.20, 2000
- Thermal Protective Performance (TPP) value: with the spacer 7.5 / contact test 5.9
- Meets ASTM F1506-10a, NFPA 70E and CSA Z462-15
- ATPV 9 cal/cm² (Arc Thermal Protective Value)
- ARC 2 Arc Rating Category (HRC 2)
- Sewn with inherently FR thread
- Left chest pocket
- Crew collar neck
- Comfort knit cuffs



PROD. NO.	MOD. NO.	Colour	Sizes
V2580310	333	Light Grey	S-5XL
V2580380	333	Navy	S-5XL
V2580370	333BK	Black	S-5XL

Flame Resistant Long-Sleeved Cotton Safety Shirt

- 100% FR treated preshrunk cotton, 7.5 oz (250 GSM)
- Material and all components meet CGSB 155.20, 2000
- Thermal Protective Performance (TPP) value: with the spacer 7.5 / contact test 5.9
- CSA Z96-09 Class 1 Level 2 and Class 1 Level FR
- Meets ASTM F1506-10a, NFPA 70E and CSA Z462-15
- ATPV 9 cal/cm² (Arc Thermal Protective Value)
- ARC 2 Arc Rating Category (HRC 2)
- StarTech™ FR reflective tape
- Sewn with inherently FR thread
- Self fabric crew neck
- Chest pocket with hook and loop closure



PROD. NO.	MOD. NO.	Colour	Sizes
V2580550	339SF	Orange	S-5XL
V2580570	340SF	Black	S-5XL

Flame Resistant Cotton Denim Shirt

- 100% FR treated preshrunk cotton denim
- Material and all components meet CGSB 155.20, 2000
- Thermal Protective Performance (TPP) value: with the spacer 7.8 / contact test 6.6
- Sewn with inherently FR thread
- 2 spade chest pockets with buttons
- Button-down collar
- Stitched-on front placket with press snaps
- Pen slot on left chest pocket flap



PROD. NO.	MOD. NO.	Colour	Sizes
V2580110	330	Stonewash Denim	S-4XL



FR PVC RAINWEAR

Flame Resistant PVC Long Rain Coat

- 48" length
- .35 mm FR treated PVC/poly/PVC
- Meets CGSB 155.20, 2000 Type 3
- 100% waterproof
- Zip and snap front placket
- Detachable snap hood



PROD. NO.	MOD. NO.	Colour	Sizes
V3510560	580	Yellow	S-5XL



Flame Resistant PVC Heavy-Duty 3-Piece Rain Suit

- Heavy-duty .45 mm FR treated PVC/polyester/PVC
- Meets CGSB 155.20, 2000 Type 3
- 100% waterproof
- 3 pieces: jacket with snaps and detachable snap hood, double bib reversible pant with elastic suspenders



PROD. NO.	MOD. NO.	Colour	Sizes
V3510160	571	Yellow	S-5XL



Flame Resistant PVC 2-Piece Rain Suit

- .35 mm FR treated PVC/poly/PVC
- Meets CGSB 155.20, 2000 Type 3
- 100% waterproof
- 2 patch pockets
- 2 pieces: jacket with zip and snap front placket, detachable snap hood and bib pant with self fabric suspenders



PROD. NO.	MOD. NO.	Colour	Sizes
V3510360	578	Yellow	S-6XL



Flame Resistant PVC 2-Piece Rain Suit

- .35 mm FR treated PVC/poly/PVC
- Meets CGSB 155.20, 2000 Type 3
- 100% waterproof
- 2 pieces: jacket with zip and snap front placket, detachable snap hood and bib pant with self fabric suspenders



PROD. NO.	MOD. NO.	Colour	Sizes
V3510460	579	Premium Orange	S-5XL

NEW

See page 797 for non-FR PVC rainwear

Element FR™ PVC 3-Piece Suit

- 13 oz/yd² PVC on polyester
- Material and all components meet CGSB 155.20, 2000 Type 3
- R85 - CSA Z96 striping package featuring retroreflective striping
- R85 - Jacket is CSA Z96-09 Class 2 Level 2, jacket and pants are Class 3 when worn together
- Oil resistant
- Extremely durable and comfortable
- Remains flexible in cold conditions
- Permanently welded seams
- Good tear and snag resistance
- Generous styling fits over work clothes



JACKET:

- Dolman sleeve design
- Stand-up collar with durable snaps to attach hood
- Concealed nylon snap front closure
- Inner storm flap
- Two snap adjustments at cuffs
- Unique Wideweld cuff design for added durability

HOOD:

- Fits easily over hard hat
- Attaches to jacket with plastic snaps
- Detachable to prevent entanglement while working
- Drawstring with cord locks for best fit

PANT:

- Single bib design
- Double-layer top for durability
- Elastic waist back
- Adjustable elastic suspenders with spreader bar and nylon slides provide support and comfort
- Two snap adjustments at cuffs for best fit
- Unique Wideweld cuff design for added durability
- Roomy legs to easily put on boots

PROD. NO.	MOD. NO.	Colour	Sizes
V2243650	R80	Hi-Viz Orange	S-4XL
V2243950	R85	Hi-Viz Orange	S-4XL



R80



R85

**CA-43® CHEMICAL AND ACID RESISTANT FR RAINWEAR****CA-43® FR Protective Coat**

- 10 oz/yd² FR PVC/polyester
- Dolman sleeves for ease of movement and added comfort
- Collar with snaps to attach hood (sold separately)
- Snap front closure
- Inner cone cuff designed to grip glove and create a seal around wrist
- Durable non-conductive plastic snaps
- RF welded watertight seams
- Generous styling fits over work clothes
- Meets CGSB 155.20-2000, Type 3
- Recommended for "Momentary Protection from Open Flame"
- Resistant to chemicals as per ASTM F739-07 • Meets CSA Class 1 Level 2



PROD. NO.	MOD. NO.	Colour	Sizes
-----------	----------	--------	-------

V2241740	C43 320	Green	XS-5XL
----------	----------------	-------	--------

NEW

J43 380

J43 320

CA-43® FR Protective Jacket

- 10 oz/yd² FR PVC/polyester
- RF welded watertight seams
- Non-conductive collar snaps to attach hood (sold separately)
- Generous styling fits over work clothes
- Meets CGSB 155.20-2000, Type 3
- Recommended for "Momentary Protection from Open Flame"
- Resistant to chemicals as per ASTM F739-07
- J43 380 - Raglan sleeves for ease of movement and added comfort, brass zipper closure with concealed outer non-conductive snaps, inner cone cuff designed to grip glove and create a seal around wrist, double storm flap, two-snap cuff adjustment
- J43 320 - Dolman sleeves for ease of movement and added comfort, snap front closure, durable non-conductive plastic snaps, CSA Class 1 Level 2, 2" wide FR silver striping on arms, torso, front, and X on back (CSA configuration)



PROD. NO.	MOD. NO.	Colour	Sizes
-----------	----------	--------	-------

V2240640	J43 380	Green	S-4XL
V2241940	J43 320	Green	S-4XL

NEW**NEW**

P43 035

P43 085

CA-43® FR Protective Bib Pant

- 10 oz/yd² FR PVC/polyester
- Single bib design
- Adjustable 1¼" elastic suspenders with spreader bar and nylon slides provide support and comfort
- Durable reinforced waist ties for snug fit
- RF welded watertight seams
- Generous styling fits over work clothes
- Meets CGSB 155.20-2000, Type 3
- Recommended for "Momentary Protection from Open Flame"
- Resistant to chemicals as per ASTM F739-07
- P43 085 - Inner elastic cuffs at bottom, double knee
- P43 035 - 2" FR silver reflective tape around legs



PROD. NO.	MOD. NO.	Colour	Sizes
-----------	----------	--------	-------

V2241340	P43 085	Green	S-4XL
V2241020	P43 035	Green	S-4XL

NEW**NEW**

CA-43® CHEMICAL AND ACID RESISTANT FR RAINWEAR

FLAME-GARD™

ranpro

PIONEER

PIONEER

FLAME RESISTANT WEAR

CA-43® FR Hood

- 10 oz/yd² FR PVC/polyester
- Fits easily over hard hat, drawstring for best fit
- Non-conductive snap attachments
- 3-piece hood design



PROD. NO. MOD. NO. Colour Sizes

V2240540 H43 501 Green Fit-All

NEW



CA-43® FR Apron

- 10 oz/yd² FR PVC/polyester
- 29" x 48" bib style apron
- Chemical and acid resistant
- Durable waist and neck ties
- Reinforced grommets at tie points



PROD. NO. MOD. NO. Colour Sizes

V2240140 A43 48 Green Fit-All

NEW



DRY GEAR® FR RAINWEAR

Dry Gear® FR Apron

- FR PU coated on FR polyester stretch knit
- Fabric meets CGSB 155.20-2000, Type 3
- Excellent cold flex, oil and abrasion resistance
- Seamless cut with grommets for straps
- Fabric meets CSA Z96-09 hi-viz background requirements



PROD. NO. MOD. NO. Colour Sizes

V3240960 A11 48 Fluorescent Yellow 29"x48"

NEW



Dry Gear® FR Sleeves

- FR PU coated on FR polyester stretch knit
- Fabric meets CGSB 155.20-2000, Type 3
- Excellent cold flex, oil and abrasion resistance
- Fabric meets CSA Z96-09 hi-viz background requirements
- SL11 180 - Crimped elastic at top, flat elastic at wrist
- SL11 200 - Comfortable Neoprene cuff keeps water out, adjustable elastic hook and loop closure at top



PROD. NO. MOD. NO. Colour Sizes

V3240860 SL11 180 Fluorescent Yellow 20"

V3240870 SL11 200 Fluorescent Yellow 22"

NEW

NEW



**PETRO-GARD® FR NEOPRENE RAINWEAR****Petro-Gard® FR Jacket**

- 14 oz/yd² low smoke Neoprene on Dupont™ Nomex®
- Inner and outer storm flaps/zipper closure
- Hard hat sized hood rolls up in collar (sold separately)
- Angled collar under the chin with FR hook and loop closure
- Two front pockets with flaps and FR hook and loop closure
- Dolman sleeve design • Inner elastic cuffs
- Tab style hook and loop cuff adjustments
- Meets FR ASTM F1891-06 Standard Specifications for Arc and Flame Resistant Rainwear
- ARC rating: ATPV 13.3 cal/cm², EBTA 40.8 cal/cm², HAF 80.6%
- NFPA 70E and CSA Z462-12 arc category 2
- Meets CGSB 155.20-2000 Workwear for Protection Against Hydrocarbon Flash Fire
- Type 1 single layer garment • TPP: with spacer 15, without spacer 4
- Meets ASTM F2733 Standard Specification for Flame Resistant Rainwear for Protection Against Flame Hazards
- Jacket meets CSA Z96-09/ANSI 107 Class 2 Level 2 and Class 2 Level 2 when worn with pant



PROD. NO.	MOD. NO.	Colour	Sizes
V2246450	J160 400	Orange	S-4XL

NEW**Petro-Gard® FR Hood**

- 14 oz/yd² low smoke Neoprene on Dupont™ Nomex®
- Drawstring and toggle, hook and loop connection to jacket



PROD. NO.	MOD. NO.	Colour	Sizes
V2246120	H160 501	Orange	O/S

NEW**Petro-Gard® FR Bib Pant**

- 14 oz/yd² low smoke Neoprene on Dupont™ Nomex®
- Single bib design
- Adjustable FR hook and loop closure leg cuff
- Adjustable arc resistant fabric suspenders and spreader bar with elastic back and Kwik-Lok connectors
- Adjustable spreader bar at back
- Durable reinforced waist ties for snug fit • 2" FR reflective material on each leg
- Meets FR ASTM F1891-06 Standard Specifications for Arc and Flame Resistant Rainwear
- ARC rating: ATPV 13.3 cal/cm², EBTA 40.8 cal/cm², HAF 80.6%
- NFPA 70E and CSA Z462-12 arc category 2
- Meets CGSB 155.20-2000 Workwear for Protection Against Hydrocarbon Flash Fire
- Type 1 single layer garment • TPP: with spacer 15, without spacer 4
- Meets ASTM F2733 Standard Specification for Flame Resistant Rainwear for Protection Against Flame Hazards
- Pant: Class 3 Level 2 when worn with Class 2 jacket



PROD. NO.	MOD. NO.	Colour	Sizes
V2246750	P160 041	Orange	S-4XL

NEW

Utili-Gard® FR Jacket

- J162 310DH - 8 oz/yd² PVC on Dupont™ Nomex®/Kevlar®
- J163 310DH and J161 310DH - 10 oz/yd² PVC on Dupont™ Nomex®/Kevlar® • Meets CGSB 122.20, 2000 Type 3
- Meets CSA Z96-09/ANSI 107 Class 2 Level 2 high-visibility safety apparel standards, Class 3 when worn with Utili-Gard® pants
- Meets ASTM F1891-06 Standard Specification for Arc and Flame Resistant Rainwear, NFPA 70E-12 and CSA Z462-12
- J162 310DH - ATPV 12.9 cal/cm², EBTAS 41.2 cal/cm², HAF 80%
- J163 310DH - ATPV 14 cal/cm², EBTAS 42.6 cal/cm², HAF 84.6%
- J161 310DH - ATPV 10.8 cal/cm², EBTAS 47.6 cal/cm², HAF 82.2%
- 2" wide FR silver striping on arms, torso, front, and X on back (CSA configuration)
- Dolman sleeve design for ease of movement • FR brass zipper
- Outer storm flap with top to bottom FR hook and loop closure
- Inner storm flap for reduced heat transmission
- Form-fitting collar has pouch for detachable hood with FR hook and loop closure
- Hood sold separately • Tab style FR hook and loop cuff adjustments
- Vented back • FR elastic drawstring on inner bottom hem to prevent arc exposure



PROD. NO.	MOD. NO.	Colour	Sizes
V2449320	J162 310DH	International Orange	XS-4XL
V2449560	J163 310DH	Fluorescent Yellow	M-2XL
V2449650	J161 310DH	Fluorescent Orange	M-2XL



Utili-Gard® FR Hood

- H162 502 - 8 oz/yd² PVC on Dupont™ Nomex® / Dupont™ Kevlar®
- H161 502/H163 502 - 10 oz/yd² PVC on Dupont™ Nomex® / Dupont™ Kevlar® • Fits easily over a hard hat
- Non-conductive, non-corrosive snaps • Drawstring for custom fit • 3-piece hood design



PROD. NO.	MOD. NO.	Colour	Sizes
V2440620	H162 502	International Orange	O/S
V2440660	H163 502	Fluorescent Yellow	O/S
V2440650	H161 502	Fluorescent Orange	O/S



Utili-Gard® FR Bib Pant

- P162 041 - 8 oz/yd² PVC on Dupont™ Nomex®/Kevlar®
- P163 041/P161 041 - 10 oz/yd² PVC on Dupont™ Nomex®/Kevlar®
- Meets CGSB 122.20, 2000 Type 3
- Meets CSA Z96-09/ ANSI 107 Class 3 Level 2 high-visibility safety apparel standards, when worn with CSA Class 2 Level 2 top featuring reflective arm bands
- Meets ASTM F1891-06 Standard Specification for Arc and Flame Resistant Rainwear, NFPA 70E-12 and CSA Z462-12
- P162 041 - ATPV 12.9 cal/cm², EBTAS 41.2 cal/cm², HAF 80%
- P163 041 - ATPV 14 cal/cm², EBTAS 42.6 cal/cm², HAF 84.6%
- P161 041 - ATPV 10.8 cal/cm², EBTAS 47.6 cal/cm², HAF 82.2%
- 2" FR silver reflective striping meets CSA Z96-09 high-visibility safety apparel standards
- Single bib design with inner bib pocket
- Adjustable arc resistant fabric suspenders and spreader bar with elastic back and Kwik-Lok connectors • Adjustable spreader bar at back
- Roomy legs to easily put on boot • Durable reinforced waist ties for snug fit



PROD. NO.	MOD. NO.	Colour	Sizes
V2448450	P162 041	International Orange	XS-4XL
V2440260	P163 041	Fluorescent Yellow	M-2XL
V2440550	P161 041	Fluorescent Orange	M-2XL





FR PU STRETCH RAINWEAR

Flame Resistant PU Stretch Hi-Viz Waterproof Jacket

- FR treated 100% polyurethane/poly
- Meets CGSB 155.20, 2000 Type 3
- 5894 - CSA Z96-09 Class 2 Level 2 and Class 2 Level FR (becomes Class 3 when worn with FR hi-viz pant featuring reflective leg bands)
- 5892/5894BK - CSA Z96-09 Class 1 Level 2 and Class 1 Level FR
- Passes ASTM D6413-13 flame resistance test
- Oil and chemical resistant
- 100% waterproof and windproof
- Lightweight and tough 4-way stretch PU
- StarTech™ FR reflective tape
- Heat welded seams
- Extra-large detachable hood
- Full front zipper with snap storm placket



PROD. NO.	MOD. NO.	Colour	Sizes
V3520150	5892	Hi-Viz Orange	XS-7XL
V3520160	5894	Hi-Viz Yellow/Green	XS-4XL
V3520170	5894BK	Black	XS-5XL

Flame Resistant PU Stretch Hi-Viz Waterproof Bib Pant

- FR treated 100% polyurethane/poly
- Meets CGSB 155.20, 2000 Type 3
- 5895 - CSA Z96-09 Class 3 Level 2 and Class 3 Level FR when worn with Class 2 Level 2 and Class 2 Level FR top featuring reflective arm bands
- 5893/5895BK - CSA Z96-09 Class 1 Level 2 and Class 1 Level FR when worn with Class 1 Level 2 and Class 1 Level FR top
- Passes ASTM D6413-13 flame resistance test
- Oil and chemical resistant
- 100% waterproof and windproof
- Lightweight and tough 4-way stretch PU
- StarTech™ FR reflective tape
- Heat welded seams
- Heavy-duty suspenders with quick-release clips
- Adjustable waist with snaps



PROD. NO.	MOD. NO.	Colour	Sizes
V3520250	5893	Hi-Viz Orange	XS-7XL
V3520260	5895	Hi-Viz Yellow/Green	XS-4XL
V3520270	5895BK	Black	XS-5XL



Flame Resistant PU Stretch Hi-Viz Long Waterproof Coat

- FR treated 100% polyurethane/poly
- Meets CGSB 155.20, 2000 Type 3
- 5897 - CSA Z96-09 Class 3 Level 2 and Class 3 Level FR
- 5896 - CSA Z96-09 Class 1 Level 2 and Class 1 Level FR
- Passes ASTM D6413-13 flame resistance test
- Oil and chemical resistant
- 100% waterproof and windproof
- Lightweight and tough 4-way stretch PU
- StarTech™ FR reflective tape
- Heat welded seams
- Extra-large detachable hood
- Full front zipper with snap storm placket



PROD. NO.	MOD. NO.	Colour	Sizes
V3520350	5896	Hi-Viz Orange	S-5XL
V3520360	5897	Hi-Viz Yellow/Green	XS-5XL



Flame Resistant PU Stretch Hi-Viz Waterproof Pant

- FR treated 100% polyurethane/poly
- Meets CGSB 155.20, 2000 Type 3
- 5899 - CSA Z96-09 Class 3 Level 2 and Class 3 Level FR when worn with Class 2 Level 2 and Class 2 Level FR top featuring reflective arm bands
- 5898 - CSA Z96-09 Class 1 Level 2 and Class 1 Level FR when worn with Class 1 Level 2 and Class 1 Level FR top featuring reflective arm bands
- Passes ASTM D6413-13 flame resistance test
- Oil and chemical resistant
- 100% waterproof and windproof
- Lightweight and tough 4-way stretch PU
- StarTech™ FR reflective tape
- Heat welded seams
- Adjustable drawstring waist



PROD. NO.	MOD. NO.	Colour	Sizes
V3520450	5898	Hi-Viz Orange	S-5XL
V3520460	5899	Hi-Viz Yellow/Green	XS-5XL





FR HEADWEAR

Flame Resistant Quilted Hard Hat Liner

- 100% FR treated 5 oz (170 GSM) woven cotton shell
- Shell fabric meets CGSB 155.20, 2000
- FR treated brushed cotton lining
- No mouthpiece
- Helmet secure straps



PROD. NO.	MOD. NO.	Colour	Sizes
V4510870	564A	Black	Fit-All

Flame Resistant Quilted Long Neck Hard Hat Liner

- 100% FR treated 5 oz (170 GSM) woven cotton shell
- Shell fabric meets CGSB 155.20, 2000
- FR treated brushed cotton lining
- Long neck with detachable mouthpiece
- Helmet secure straps
- Sewn with inherently FR thread



PROD. NO.	MOD. NO.	Colour	Sizes
V4510970	565A	Black	Fit-All

Flame Resistant Quilted Hard Hat Liner

- 100% FR treated 5 oz (170 GSM) woven cotton shell
- Shell fabric meets CGSB 155.20, 2000
- FR treated brushed cotton lining
- Detachable mouthpiece
- Helmet secure straps
- Sewn with inherently FR thread



PROD. NO.	MOD. NO.	Colour	Sizes
V4511070	566A	Black	Fit-All

Heavy-Duty Flame Resistant Quilted Long Neck Hard Hat Liner

- 100% FR treated 5 oz (170 GSM) woven cotton shell
- Shell fabric meets CGSB 155.20, 2000
- FR treated brushed cotton lining
- Long neck with detachable mouthpiece
- Helmet secure straps



PROD. NO.	MOD. NO.	Colour	Sizes
V4512070	5565A	Black	Fit-All

Nomex® IIIA Toque

- Nomex® IIIA life-long flame resistant



PROD. NO.	MOD. NO.	Colour	Sizes
V4520270	C200	Black	Fit-All



Nomex® IIIA Beanie

- Nomex® IIIA life-long flame resistant
- Tight-knit for best fit



PROD. NO.	MOD. NO.	Colour	Sizes
V4520370	C201	Black	Fit-All



Nomex® Neck Warmer/Windguard

- Nomex® life-long flame resistant



PROD. NO.	MOD. NO.	Colour	Sizes
V4520510	C207	Natural	Fit-All



Nomex® IIIA Neck Warmer/Windguard

- Nomex® IIIA life-long flame resistant



PROD. NO.	MOD. NO.	Colour	Sizes
V4520570	C207BK	Premium Black	Fit-All



Nomex® IIIA 3-Hole Balaclava

- Nomex® IIIA life-long flame resistant
- 3 holes



PROD. NO.	MOD. NO.	Colour	Sizes
V4520470	C202	Black	Fit-All





FR HEADWEAR

Nomex® IIIA 1-Hole Balaclava

- Nomex® IIIA life-long flame resistant
- 1 hole



PROD. NO.	MOD. NO.	Colour	Sizes
V4520170	666	Black	Fit-All



Nomex® IIIA Light-Knit Balaclava

- Nomex® IIIA life-long flame resistant
- 1 hole



PROD. NO.	MOD. NO.	Colour	Sizes
V4520970	C215	Black	Fit-All



Nomex® Medium-Knit Balaclava

- Nomex® life-long flame resistant
- 1 hole
- 4-piece cape/hood design



PROD. NO.	MOD. NO.	Colour	Sizes
V4520710	C214	White	Fit-All



Nomex® IIIA Medium-Knit Balaclava

- Nomex® IIIA life-long flame resistant
- 1 hole
- 4-piece cape/hood design



PROD. NO.	MOD. NO.	Colour	Sizes
V4520770	C214BK	Premium Black	Fit-All



WORK/REC APPAREL

**WORK SAFE.
PLAY SAFE.**

783



POLY/COTTON COVERALLS

Poly/Cotton Coverall

- 7 oz (230 GSM) poly/cotton
- 2-way heavy-duty brass zipper
- Adjustable snap wrists
- 7 storage pockets: 2 back, 2 chest, 2 side, 1 tool
- 2 pass-through pockets
- Action back and elastic waist

PROD. NO.	MOD. NO.	Colour	Sizes
V2020380	515	Navy	36-60
V202038T	515T	Navy	40T-60T



COTTON COVERALLS

Cotton Coverall with Buttons

- 100% preshrunk 8 oz (270 GSM) cotton
- Brass button closure
- Adjustable snap wrists
- 7 storage pockets: 2 back, 2 chest, 2 side, 1 tool
- 2 pass-through pockets
- Action back and elastic waist

PROD. NO.	MOD. NO.	Colour	Sizes
V2010110	5133	Blue with Navy Trim	36-60
V201011T	5133T	Blue with Navy Trim	40T-60T

COTTON COVERALLS

Heavy-Duty Industrial Wash Cotton Coverall

- 100% preshrunk 8.5 oz cotton (290 GSM) cotton
- Heavy-duty cotton twill material suitable for industrial wash
- Brass button closure
- Adjustable snap wrists
- 7 storage pockets: 2 back, 2 chest, 2 side, 1 tool
- Pen slot pockets on chest and arm
- 2 pass-through pockets
- Action back and reinforced waist

PROD. NO.	MOD. NO.	Colour	Sizes
V2010380	5134	Navy	36-60
V201038T	5134T	Navy	40T-60T



SHOP COATS

Poly/Cotton Shop Coat

- 7.5 oz (255 GSM) poly/cotton
- Sanforized for shrinkage of less than 1%
- Permanent-press, wrinkle-free
- Action back
- Snap front covered by placket
- 2 large front pockets
- Chest pocket with pen slot
- Bartacked pockets

PROD. NO.	MOD. NO.	Colour	Sizes
V2020180	512	Navy	S-5XL





EUROWEAR™

EuroWear™ Work Jacket

- Heavy-duty, 65% polyester 35% cotton, 10 oz (340 GSM) canvas
- Key seams triple stitched for maximum strength
- YKK brass front zipper
- Cell phone pocket
- 4 tool and storage pockets
- Comfortable action back
- Brass snap adjustable wrists
- Waist adjustor tabs

PROD. NO.	MOD. NO.	Colour	Sizes
V2040370	7010	Black	S-3XL



EuroWear™ Coverall

- Heavy-duty, 65% polyester 35% cotton, 10 oz (340 GSM) canvas
- Key seams triple stitched for maximum strength
- Cordura®-reinforced knees and ankles
- YKK brass front zipper
- Knee pouches for inserting #160 or #162 knee pads (sold separately)
- Cell phone pocket
- 10 tool and storage pockets
- Pen and knife slots
- Comfortable action back
- Brass snap adjustable wrists
- Waist adjustor tabs

PROD. NO.	MOD. NO.	Colour	Sizes
V2040170	7000	Black	36-54

Cordura®-reinforced knees and ankles



EuroWear™ Overall

- Heavy-duty, 65% polyester 35% cotton, 10 oz (340 GSM) canvas
- Key seams triple stitched for maximum strength
- Cordura®-reinforced knees and ankles
- YKK brass fly access zipper
- Knee pouches for inserting #160 or #162 knee pads (sold separately)
- Cell phone pocket
- 9 tool and storage pockets
- Pen and knife slots
- Comfortable elastic waist with button adjustment
- Suspenders with quick-release buckle and elastic panel

PROD. NO.	MOD. NO.	Colour	Sizes
V2040270	7005	Black	36-54



Cordura®-reinforced knees and ankles



EuroWear™ Work Pant

- Heavy-duty, 65% polyester 35% cotton, 10 oz (340 GSM) canvas
- 7015SF - StarTech™ reflective tape
- Key seams triple stitched for maximum strength
- Cordura®-reinforced knees and ankles
- YKK brass fly access zipper
- Knee pouches for inserting #160 or #162 knee pads (sold separately)
- 8 tool and storage pockets
- Pen and knife slots
- Hammer loop
- Extra-wide belt loops

PROD. NO.	MOD. NO.	Colour	Sizes
V2040470	7015	Black	See chart below
V2040480	7015SF	Black	See chart below
V2040440	7016	Beige	See chart below

**NEW
NEW**



		Width							
		30	32	34	36	38	40	42	44
Length	30								
	32								
	34								



KNEE PADS

Insert Style Knee Pad

- Ergonomic design
- Comfortable, lightweight kneeling protection
- Fits all insert style knee pad garments
- 100% polyethylene
- Hang carded

PROD. NO.	MOD. NO.	Colour	Sizes
V2050170	160	Black	Fit-All



Insert Style Gel Knee Pad

- Tough heavy-duty design
- Comfortable kneeling protection
- Fits all insert style knee pad garments
- 100% polyethylene
- Hang carded

PROD. NO.	MOD. NO.	Colour	Sizes
V2050270	162	Black	Fit-All



Professional Gel Knee Pad

- Flexible silicone gel pad memory insert for superior working comfort
- Meets EN 14404:2004+A1 Type 1 standard for knee protection
- Industrial strength PVC limited slip cap for long-wearing protection
- Thick memory foam for extra support
- Water-resistant oxford polyester outer material
- Breathable, adjustable Neoprene strap for comfortable all-day wear
- Packaged in full colour display box

PROD. NO.	MOD. NO.	Colour	Sizes
V2050370	165	Black	Fit-All



Heavy-Duty Professional Gel Knee Pad

- Tough 1680D ballistic polyester resists tears and punctures
- Breathable Neoprene lower strap for all-day comfort
- Second quick clip-on strap for secure positioning
- Gel centre distributes weight evenly
- 16 mm EVA foam provides extra comfort
- Oversize PVC hard shell cap for extra protection and prevention of rollover

PROD. NO.	MOD. NO.	Colour	Sizes
V2050470	167	Black	Fit-All



Breathable Air Vented Professional Gel Knee Pad

- Durable 600D ripstop polyester with multi-layer breathable fabric panels to keep you cool all day
- Breathable Neoprene lower strap for comfort
- Elastic upper strap with quick-release clip provides secure fit
- Gel cushion with 10 mm EVA padding provides comfortable protection
- Durable PVC hard shell cap shields the knee from hazards



PROD. NO.	MOD. NO.	Colour	Sizes
V2050570	168	Black	Adjustable, fits XS to M
V2050670	169	Black	Adjustable, fits L to 4XL





ranpro



CLIPPER® COMMERCIAL FISHING RAINWEAR

Clipper® Hooded Jacket

- 14.75 oz/yd² PVC double-coated on woven polyester fabric
- Roomy raglan sleeves
- Attached, shaped hood design directs water off face
- Adjust-a-size, double RF welded cuffs offer customized fit and greater durability
- Inner hood drawstring with fastened ends and cord locks for added safety and comfort
- Non-corrosive zipper provides excellent durability in cold temperatures and salt water environments; larger pull is easily manipulated with a gloved hand
- Reflective material on hood and shoulders for greater visibility



PROD. NO.	MOD. NO.	Colour	Sizes
V3241420	J136 347H	Red	XS-5XL

NEW

Clipper® Bib Pant

- 14.75 oz/yd² PVC double-coated on woven polyester fabric
- Double bib pant design offers greater protection and durability
- Soft hand cozy adjustable suspenders for added comfort
- Double stitched locker loop for ease of hanging after use
- Adjust-a-size, double RF welded hems offer customized fit and greater durability
- Extra-large, double thickness thigh-high front leg patch for increased abrasion resistance
- Durable reinforced waist ties for snug fit
- Adjustable elastic suspenders with spreader bar and nylon slides provide support and comfort
- Designed to fit over work clothes, providing mobility and ease of movement
- Wider leg easily fits over boots • Reflective material on bib for greater visibility



PROD. NO.	MOD. NO.	Colour	Sizes
V3241620	P136 070	Red	XS-5XL

NEW

CANADIAN RAINWEAR

Canadian Hooded Rain Jacket

- 13 oz/yd² PVC double-coated on polyester
- Attached hood with internal drawstring
- Fabric is marine fish oil resistant • Roomy raglan sleeves
- Concealed corrosion resistant brass snap closure • Inner storm flap to keep out elements



PROD. NO.	MOD. NO.	Colour	Sizes
V3242040	J35 345H	Olive Green	XS-5XL

NEW

Canadian Rain Bib Pant

- 13 oz/yd² PVC double-coated on polyester
- Double bib design for longer wear
- Fabric is marine fish oil resistant • Durable reinforced waist ties for snug fit
- Adjustable elastic suspenders with spreader bar and nylon slides provide support and comfort • Roomy legs to easily put on boots



PROD. NO.	MOD. NO.	Colour	Sizes
V3242540	P35 060	Olive Green	S-4XL

NEW

CANADIAN RAINWEAR

Canadian Sleeves

- 13 oz/yd² PVC double-coated on polyester
- Fabric is marine fish oil resistant
- Crimped elastic at top, flat elastic at wrist



PROD. NO.	MOD. NO.	Colour	Sizes
V3247920	SL35 155	Olive Green	17"

NEW

ranpro



FL SNAPPER® HEAVY-DUTY RAINWEAR

FL Snapper® Hooded Jacket

- 14.5 oz/yd² PVC on poly-cotton blend
- Roomy raglan sleeves
- Fabric is abrasion and tear resistant
- Attached hood with draw cord fits over ball cap
- Sewn and double RF welded outer cuffs
- Reinforced, concealed corrosion resistant brass snap closure
- Inner storm flap to keep elements out



PROD. NO.	MOD. NO.	Colour	Sizes
V3246250	J30 345H	Fluorescent Orange	XS-5XL

NEW

FL Snapper® Rain Bib Pant

- 14.5 oz/yd² PVC on poly-cotton blend
- Double bib design for added protection and longer life
- Fabric is abrasion and tear resistant
- Durable reinforced waist ties for snug fit
- Adjustable elastic suspenders with spreader bar and nylon slides provide support and comfort
- Roomy legs to easily put on boots



PROD. NO.	MOD. NO.	Colour	Sizes
V3246850	P30 060	Fluorescent Orange	XS-5XL

NEW



SNAPPER® HEAVY-DUTY RAINWEAR

Snapper® Apron

- 14.5 oz/yd² PVC on poly-cotton blend
- 29"X48" bib style apron
- Fabric is abrasion and tear resistant
- Durable waist and neck ties
- Reinforced grommets at tie point



PROD. NO.	MOD. NO.	Colour	Sizes
V3246420	A30 48	Moss Green	Fit-All

NEW





SNAPPER® HEAVY-DUTY RAINWEAR

Snapper® Rain Jacket with Hood

- 14.5 oz/yd² PVC on poly-cotton blend
- Roomy raglan sleeves
- Fabric is abrasion and tear resistant
- Attached hood with draw cord fits over ball cap
- Sewn and double RF welded outer cuffs
- Reinforced, concealed corrosion resistant brass snap closure
- Inner storm flap to keep elements out



PROD. NO.	MOD. NO.	Colour	Sizes
V3246440	J34 345H	Moss Green	XS-5XL

NEW

Snapper® Rain Bib Pant

- 14.5 oz/yd² PVC on poly-cotton blend
- Double bib design for added protection and longer life
- Fabric is abrasion and tear resistant
- Durable reinforced waist ties for snug fit
- Adjustable elastic suspenders with spreader bar and nylon slides provide support and comfort
- Roomy legs to easily put on boots



PROD. NO.	MOD. NO.	Colour	Sizes
V3246640	P34 060	Moss Green	XS-5XL

NEW

90° NORTH WATER-RESISTANT WEAR

90° North Pullover

- 15 oz/yd² PVC/polyurethane coated polyester knitted fabric with fleece backing
- Soft and flexible water resistant outer layer keeps you dry
- Fleece fabric liner is comfortable against your skin and keeps you warm
- Extended neck zipper design for greater protection from the elements
- Waterproof zipper with gusset
- Waterproof RF welded seams
- Neoprene cuffs to keep water outfit snug to the wrist
- Fitted hood with hidden drawstring pull cord
- Increased softness and cold flex even in the harshest of conditions
- Extremely comfortable
- Remains flexible down to -20°C



PROD. NO.	MOD. NO.	Colour	Sizes
V3247420	JP33 250H	Red	XS-5XL

NEW

Rainshield® Jacket

- 10 oz/yd² PVC/nylon/PVC with anti-fungal treatment
- Detached hood (sold separately) with draw strings
- Interior PVC coating sheds water and makes for easy cleaning
- High tear and abrasion resistance
- Anti-fungal and anti-mildew treated fabric
- Brass button closure to prevent dirt and grime build-up
- Elastic bottom and arm closure
- Inner storm flap provides extra barrier from wetness
- Roomy raglan sleeves

PROD. NO.	MOD. NO.	Colour	Sizes
V3246950	J25 261H	Orange	XS-5XL

NEW



Rainshield® Bib Pant

- 10 oz/yd² PVC/nylon/PVC with anti-fungal treatment
- Single bib design
- Interior PVC coating sheds water and makes for easy cleaning
- High tear and abrasion resistance
- Anti-fungal and anti-mildew treated fabric
- Durable reinforced waist ties for snug fit
- Adjustable elastic suspenders with spreader bar

PROD. NO.	MOD. NO.	Colour	Sizes
V3245050	P25 025	Orange	XS-5XL

NEW



Rainshield® Hood

- 10 oz/yd² PVC/nylon/PVC with anti-fungal treatment
- Drawstring and snaps
- Interior PVC coating sheds water and makes for easy cleaning
- High tear and abrasion resistance
- Anti-fungal and anti-mildew treated fabric
- 3-piece hood design

PROD. NO.	MOD. NO.	Colour	Sizes
V3246960	H25 501	Orange	Fit-All

NEW



Rainshield® Apron

- 10 oz/yd² PVC/nylon/PVC with anti-fungal treatment
- 29"X48" bib style apron
- Durable waist and neck ties
- Interior PVC coating sheds water and makes for easy cleaning
- High tear and abrasion resistance
- Anti-fungal and anti-mildew treated fabric
- Seamless cut to avoid hidden dirt and grease
- Grommets on corners for straps

PROD. NO.	MOD. NO.	Colour	Sizes
V3246970	A25 48	Orange	Fit-All

NEW





PU STRETCH RAINWEAR

PU Stretch Jacket

- 100% waterproof polyurethane
- Lightweight and tough 4-way stretch fabric
- Nylon tricot lining wicks away body perspiration
- Remains flexible in cold temperatures
- Oil resistant
- 2 front pockets
- Heat welded seams
- Hood folds into collar
- 2-way zipper with snap storm placket
- Adjustable wrists



PROD. NO.	MOD. NO.	Colour	Sizes
V3020140	D7000	Olive	XS-5XL
V3020180	D7000	Navy	S-3XL



PU Stretch Bib Pant

- 100% waterproof polyurethane
- Lightweight and tough 4-way stretch fabric
- Nylon tricot lining wicks away body perspiration
- Remains flexible in cold temperatures
- Oil resistant
- Heat welded seams
- Heavy-duty suspenders with quick-release clips



PROD. NO.	MOD. NO.	Colour	Sizes
V3020340	D7020	Olive	XS-5XL
V3020380	D7020	Navy	S-3XL



PU Stretch Pant

- 100% waterproof polyurethane
- Lightweight and tough 4-way stretch fabric
- Nylon tricot lining wicks away body perspiration
- Remains flexible in cold temperatures
- Oil resistant
- Heat welded seams
- Drawstring waist
- Adjustable snap ankles



PROD. NO.	MOD. NO.	Colour	Sizes
V3020540	D7183	Olive	XS-5XL
V3020580	D7183	Navy	S-3XL

HEAVYWEIGHT PVC/POLY/PVC RAINWEAR



Dry King® PVC Hooded Jacket

- Heavyweight premium .45 mm PVC/polyester/PVC
- 100% waterproof and windproof
- Triple welded seams
- Double brass snap storm placket
- Drawstring hood



PROD. NO.	MOD. NO.	Colour	Sizes
V3031140	D9010	Green	S-5XL
V3031160	D9010	Yellow	S-5XL



Dry King® PVC Reversible Bib Pant

- Heavyweight premium .45 mm PVC/polyester /PVC
- 100% waterproof and windproof
- Triple welded seams
- Reversible
- Inside bib pocket with pen slot
- Adjustable waist
- Premium elastic suspenders



PROD. NO.	MOD. NO.	Colour	Sizes
V3031340	D9020	Green	S-5XL
V3031360	D9020	Yellow	S-5XL



Dry King® PVC Jacket

- Heavyweight premium .45 mm PVC/polyester/PVC
- 100% waterproof and windproof
- Triple welded seams
- Double brass snap storm placket
- Front and back vents



PROD. NO.	MOD. NO.	Colour	Sizes
V3030760	D9000	Yellow	S-4XL





HEAVYWEIGHT PVC/POLY/PVC RAINWEAR

Dry King® Offshore Traditional Sou'Wester Hat

- Heavy-duty premium SBR vulcanized rubber compound
- 100% waterproof
- Fully cotton lined
- Large brim and lined flap
- Chin tie-down
- Glued and vulcanized for strength



PROD. NO.	MOD. NO.	Colour	Sizes
V3035060	D5050	Yellow	S-XL
V3035070	D5050	Black	S-XL



WORK/REC RAINWEAR

Trail Pak® Hooded Jacket with Waist Pant

- 2 pieces: hooded jacket and pant
- .35 mm PVC/polyester/PVC
- 100% waterproof and windproof
- Welded seams
- 2 large front cargo pockets
- Retail poly bag with insert card



PROD. NO.	MOD. NO.	Colour	Sizes
V3010140	101	Green	XS-3XL
V3010160	101	Yellow	XS-3XL





Supported PVC 3-Piece Rain Suit

- 3 pieces: jacket, detachable hood and bib pant
- .35 mm PVC/polyester/PVC
- 100% waterproof and windproof
- Jacket: vented back and underarms, 2 large front cargo pockets, zipper plus snap storm placket, welded seams, corduroy collar, detachable hood, embroidery access zipper
- Bib pant: adjustable waist and suspenders, snap fly access
- 577B - packed in hangable bag



PROD. NO.	MOD. NO.	Colour	Sizes
V3010460	577	Yellow	S-6XL
V3010461	577B	Yellow	S-4XL

NEW



Supported PVC Rain Jacket

- .35 mm PVC/polyester/PVC
- 100% waterproof and windproof
- Vented back and underarms
- 2 large front cargo pockets
- Zipper plus snap storm placket
- Welded seams
- Corduroy collar
- Detachable hood
- Embroidery access zipper



PROD. NO.	MOD. NO.	Colour	Sizes
V3010560	577J	Yellow	S-3XL

Supported PVC Rain Bib Pant

- .35 mm PVC/polyester/PVC
- 100% waterproof and windproof
- Adjustable waist and suspenders
- Snap fly access



PROD. NO.	MOD. NO.	Colour	Sizes
V3010660	577P	Yellow	S-3XL

48" Long PVC Rain Coat

- .35 mm PVC/polyester/PVC
- 100% waterproof and windproof
- Welded seams
- Detachable hood
- Zipper plus snap storm placket
- 2 large front cargo pockets
- Corduroy collar



PROD. NO.	MOD. NO.	Colour	Sizes
V3010760	581	Yellow	S-4XL



See page 772 for FR PVC rainwear



WORK/REC RAINWEAR

Hooded PVC Poncho

- 100% waterproof and windproof
- Welded seams



PROD. NO.	MOD. NO.	Colour	Sizes
V3050200	700	Transparent	Fit-All

Polyester/PVC Rain Suit

- Polyester/PVC
- 2 pieces: hooded jacket and waist pant
- 100% waterproof and windproof
- Taped and heat sealed seams
- 2 large front pockets



PROD. NO.	MOD. NO.	Colour	Sizes
V3040140	583	Green	S-4XL
V3040180	883	Navy	S-3XL



Dry King® Rain Jacket in Stuff Bag

- Polyester with PVC backing
- 100% waterproof and windproof
- Hood folds into collar
- Folds into stuff bag
- Taped and heat sealed seams
- 2 front pockets
- Vented



PROD. NO.	MOD. NO.	Colour	Sizes
V3060640	DK115J	Green	XS-3XL
V3060680	DK115J	Navy	XS-3XL



Dry King® Rain Pant in Stuff Bag

- Polyester with PVC backing
- 100% waterproof and windproof
- Folds into stuff bag
- Taped and heat sealed seams
- 2 pass-through pockets
- Adjustable snap ankles



PROD. NO.	MOD. NO.	Colour	Sizes
V3060840	DK115P	Green	S-5XL





WORK/REC RAINWEAR

Dry King® Storm Pant

- Polyester with PVC backing
- 100% waterproof and windproof
- Taped and heat sealed seams
- Elastic waist
- 2 pass-through pockets
- Adjustable snap ankles



PROD. NO.	MOD. NO.	Colour	Sizes
V3060170	150P	Black	XS-3XL

Dry King® Full Zip Storm Pant

- Polyester with PVC backing
- 100% waterproof and windproof
- Taped and heat sealed seams
- Full side zippers
- Nylon lined
- Elastic waist
- 1 rear pocket



PROD. NO.	MOD. NO.	Colour	Sizes
V3060470	D2020	Black	XS-3XL

Waterproof/Breathable Recreational Jacket

- Tough 300 Denier waterproof/breathable polyester
- 5,000 waterproof / 3,000 breathable
- Taped and heat sealed seams
- 2 waterproof zip chest pockets
- 2 large front zip cargo pockets
- Cell phone pocket
- Inside zip iPod pocket
- Comfort fleece collar and chin guard
- Adjustable waist, hem and wrists
- Embroidery access zipper

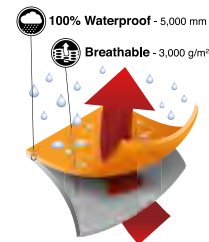

PROD. NO.	MOD. NO.	Colour	Sizes
V3060210	2100	Charcoal/Black	S-5XL
V3060220	2101	Slate Green/Black	S-5XL

Nailhead Ripstop Tree Planter Hooded Jacket

- 420 Denier oxford polyester with PVC coating
- 100% waterproof and windproof
- Taped and heat sealed seams
- Front and back vents
- 2 large front cargo pockets
- Adjustable wrists
- Detachable hood converts to jacket pouch



PROD. NO.	MOD. NO.	Colour	Sizes
V3040360	D8120J	Yellow	XS-5XL
V3040340	D8120J	Green	XS-5XL



Nailhead Ripstop Tree Planter Bib Pant

- 420 Denier oxford polyester with PVC coating
- 100% waterproof and windproof
- Taped and heat sealed seams
- Adjustable ankles
- Adjustable suspenders
- Fly access



PROD. NO.	MOD. NO.	Colour	Sizes
V3040440	D8120P	Green	XS-5XL
V3040460	D8120P	Yellow	XS-5XL





QUILTED SHIRTS, HOODIES AND VESTS

Comfortable Quilted Flannel Work Shirt

- Poly/cotton
- 3.5 oz (120 GSM) quilted poly filling
- Pearl-style snap buttons
- 2 chest pockets

PROD. NO.	MOD. NO.	Colour	Sizes
V308029A	400A	Red-Black-White Plaid	S-3XL
V308029B	400B	Blue-Black-White Plaid	S-3XL



Quilted Hooded Polar Fleece Shirt

- Boa lined
- Fooler front with buttons
- Mock hoodie inner with zipper
- Fleece lined drawstring hood
- 2 chest pockets
- Elastic wrists
- Prepack: 12 units/pkg (2/M, 4/L, 4/XL, 2/2XL)

PROD. NO.	MOD. NO.	Colour	Sizes
V3080391	415A	2 colours: Black-Grey-Tan Plaid + Black	Prepack
V3080392	415B	2 colours: Charcoal Plaid + Royal-Black Plaid	Prepack



Quilted Hooded Polar Fleece Vest

- Boa lined
- Fooler front with buttons
- Mock hoodie inner with zipper
- Fleece lined drawstring hood
- 2 chest pockets

PROD. NO.	MOD. NO.	Colour	Sizes
V3080690	414	Black-Grey-White Plaid	S-4XL

Quilted Hooded Polar Fleece Shirt

- Boa lined
- Fooler front with buttons
- Mock hoodie inner with zipper
- Fleece lined drawstring hood
- 2 chest pockets, elastic wrists

PROD. NO.	MOD. NO.	Colour	Sizes
V3080393	4155S	Royal-Black Plaid	S-4XL
V3080396	415BG	Blue-Grey Plaid	XS-2XL

NEW



Polar Fleece Hooded Shirt/Jacket

- Boa lined
- Zipper
- 2 large front pouch pockets
- Elastic cuffs
- Boa lined drawstring hood
- Prepack: 12 units/pkg (2/M, 4/L, 4/XL, 2/2XL)

PROD. NO.	MOD. NO.	Colour	Sizes
V3080590	420	2 colours: Steel-Blue-Grey-Black Plaid + Black-Grey-White Plaid	Prepack



Reversible Fleece Hoodie

- Anti-pill polar fleece
- Reversible to black fleece inner
- 2 slash pockets
- Drawstring hood
- Full front reversible zipper
- Elastic rib cuffs and hem

PROD. NO.	MOD. NO.	Colour	Sizes
V3080410	418	Black-Grey-White Plaid	S-4XL





UNDERWEAR SETS

Midweight Fleece Underwear Set

- Moisture wicking
- 2-way stretch fabric, 5.5 oz (190 GSM)
- Top and bottom packed in Pioneer vented stuff bag
- Elastic neck ribbing, cuffs and ankles
- Comfort seams
- Fly access



PROD. NO.	MOD. NO.	Colour	Sizes
V3100270	D2200M	Black	XS-3XL



Polypropylene Underwear Set

- Moisture wicking
- Comfortable first layer
- Zipper neck
- Top and bottom packed in Pioneer vented stuff sack
- Fly access



PROD. NO.	MOD. NO.	Colour	Sizes
V3100470	D2300M	Black	XS-5XL



Hi-Viz Ball Cap

- Breathable material
- Reflective binding on edge
- Adjustable hook and loop closure
- 6/pkg

PROD. NO.	MOD. NO.	Colour	Sizes
V1040650	147	Hi-Viz Orange	Fit-All
V1040660	148	Hi-Viz Yellow/Green	Fit-All



1-Hole Balaclava

- 100% acrylic knitted
- 1 hole with side slits

PROD. NO.	MOD. NO.	Colour	Sizes
V4010170	560-A	Black	Fit-All



3-Hole Balaclava

- 100% acrylic knitted
- 3 holes with side slits

PROD. NO.	MOD. NO.	Colour	Sizes
V4010270	560-B	Black	Fit-All



Insulation Lined 3-Hole Balaclava

- Insulation lined
- 3 holes



PROD. NO.	MOD. NO.	Colour	Sizes
V4020251	5569A	Hi-Viz Orange	Fit-All
V4020271	5560A	Black	Fit-All



Insulation Lined 1-Hole Balaclava

- Insulation lined
- 1 hole



PROD. NO.	MOD. NO.	Colour	Sizes
V4020151	5568A	Hi-Viz Orange	Fit-All
V4020171	5562A	Black	Fit-All





HEADWEAR

Insulation Lined Toque

- 50% wool and 50% acrylic
- Insulation lined



PROD. NO.	MOD. NO.	Colour	Sizes
V4020511	5561A	Beige	Fit-All

Insulation Lined Toque

- 100% acrylic knitted
- Insulation lined



PROD. NO.	MOD. NO.	Colour	Sizes
V4020371	5563A	Black	Fit-All
V4020351	5564A	Hi-Viz Orange	Fit-All
V4020361	5567A	Hi-Viz Yellow/Green	Fit-All

Insulation Lined Beanie

- 100% acrylic knitted
- Insulation lined



PROD. NO.	MOD. NO.	Colour	Sizes
V4020771	5570A	Black	Fit-All
V4020751	5571A	Hi-Viz Orange	Fit-All
V4020761	5572A	Hi-Viz Yellow/Green	Fit-All

Acrylic Knit Beanie

- 100% acrylic knitted

PROD. NO.	MOD. NO.	Colour	Sizes
V4010570	570	Black	Fit-All
V4010550	567	Hi-Viz Orange	Fit-All
V4010560	569	Hi-Viz Yellow/Green	Fit-All



Hat Liner/Windguard

- 100% acrylic knitted

PROD. NO.	MOD. NO.	Colour	Sizes
V4010410	561	Navy	Fit-All
V4010420	562	Red	Fit-All



Reversible Micro Fleece Hood

- Lightweight 2-layer micro fleece
- Reversible, black to hi-viz orange
- Snugger fit for superior comfort
- Hangable feature card

PROD. NO.	MOD. NO.	Colour	Sizes
V4030270	5502	Black	Fit-All



Single-Layer Micro Fleece Hood with Face Mask

- Heavyweight micro fleece for maximum warmth
- Elastic around face line
- Super-soft face mask
- Hangable feature card

PROD. NO.	MOD. NO.	Colour	Sizes
V4030370	5503	Black	Fit-All



Micro Fleece 3-in-1 Neck Warmer

- Medium weight 2-layer micro fleece
- 3-in-1 design, converts from neck warmer to hat or face mask
- Elastic drawstring with toggle
- Hangable feature card

PROD. NO.	MOD. NO.	Colour	Sizes
V4030470	5504	Black	Fit-All



Bag



Neck Warmer / Face Mask



Hat



HEADWEAR

6-in-1 Hood

- Soft 2-layer fleece with bonded inner waterproof layer
- Waterproof and windproof
- 6-in-1 design, converts to balaclava, neck warmer, face mask, beanie, scarf or bag
- Drawstring with toggle around face line and at the bottom
- Hangable display box



PROD. NO.	MOD. NO.	Colour	Sizes
V4030570	5505	Black	Fit-All



Beanie



Hood



Balaclava



Bag



Scarf



Neck Warmer /
Face Mask

Micro Fleece Hood with Zipper Front

- Medium weight 2-layer micro fleece
- Extended bib coverage
- Convenient zipper front
- Hangable feature card

PROD. NO.	MOD. NO.	Colour	Sizes
V4030670	5506	Black	Fit-All

N95 Cone-Shaped Respirator

- NIOSH approved
- Exceptional inner filter for increased breathability
- Adjustable aluminum nose clip
- Ultrasonic welded head straps for secure staple-free seal
- 20/box

PROD. NO.	MOD. NO.	Colour	Sizes
V7030200	350	White	Adjustable fit, M to L



N95 Cone-Shaped Respirator with Valve

- NIOSH approved
- Exceptional inner filter for increased breathability
- Adjustable aluminum nose clip
- Ultrasonic welded head straps for secure staple-free seal
- One-way valve for easy exhalation
- 10/box

PROD. NO.	MOD. NO.	Colour	Sizes
V7030300	355	White	Adjustable fit, M to L



N95 Flat Folded Respirator

- NIOSH approved
- Foldable, easy to carry
- Soft outer layer for comfort
- Adjustable aluminum concealed nose clip
- Fully adjustable loop head straps
- 20/box

PROD. NO.	MOD. NO.	Colour	Sizes
V7030400	360	White	Adjustable fit, M to L



Nuisance Dust Mask

- Premium cone-shaped mask
- Pliable aluminum nose clip
- Ultrasonic welded latex and staple-free head straps
- 50/box

PROD. NO.	MOD. NO.	Colour	Sizes
V7030900	390	White	Adjustable fit, M to L





DISPOSABLE GARMENTS

Polypropylene Coverall

- Basis weight 30 GSM tested ASTM D3776
- Zipper front
- Improved hood and neck design reduces leakage points
- Designed with elastic waist, ankles, and wrists for optimum fit and freedom of movement
- Serged seams
- Highly breathable, cool and comfortable
- Protection from dust, dirt and grime, oil and grease
- For non-hazardous environment applications
- Individually packed

PROD. NO.	MOD. NO.	Colour	Sizes
V7013550	2035	White	S-5XL

NEW

Polypropylene Lab Coat

- Basis weight 30 GSM tested ASTM D3776
- 4-button front
- Elastic wrists
- Serged seams
- Highly breathable, cool and comfortable
- Protection from dust, dirt and grime, oil and grease
- For non-hazardous environment applications
- 10/pkg

PROD. NO.	MOD. NO.	Colour	Sizes
V7013650	2036	White	S-4XL

NEW

DISPOSABLE GARMENTS



Polypropylene Apron

- Basis weight 30 GSM tested ASTM D3776
- Highly breathable, cool and comfortable
- Protection from dust, dirt and grime, oil and grease
- For non-hazardous environment applications
- 10/pkg

PROD. NO.	MOD. NO.	Colour	Sizes
V7013750	2037	White	28" x 42" fits most

NEW



SMS Coverall

- 3-layer Spunbound Melt-Blown Synthetic material
- Breathable while protecting from dry particulates and fluids
- Good abrasion and tear resistance
- Zipper front
- Improved hood and neck design reduces leakage points
- Designed with elastic waist, ankles, and wrists for optimum fit and freedom of movement
- Serged seams
- For non-hazardous environment applications
- Individually packed

PROD. NO.	MOD. NO.	Colour	Sizes
V7014550	2045	White	S-5XL

NEW



Physical Property	Test Method	Units	Results
Mass per Unit	ASTM D3776	GSM	40.6
Mass per Unit	ASTM D3776	oz/yd ²	1.19
Breaking Strength, Length	ASTM D5034	lbf	22
Breaking Strength, Width	ASTM D5034	lbf	30.4
Elongation, Length	ASTM D5034	%	85.3
Elongation, Width	ASTM D5034	%	80
Tearing Strength, Length	ASTM D5733	lbf	11.5
Tearing Strength, Width	ASTM D5733	lbf	8.5



DISPOSABLE GARMENTS

Microporous Coverall

- Microporous film laminate
- Breathable and comfortable
- Protects from dirt, grime and liquid splashes as well as from paints, bleach and blood
- Zipper front
- Improved hood and neck design reduces leakage points
- Designed with elastic waist, ankles, and wrists for optimum fit and freedom of movement
- Serged seams
- For non-hazardous environment applications
- Individually packed

PROD. NO.	MOD. NO.	Colour	Sizes
V7015550	2055	White	S-5XL

NEW

Physical Property	Test Method	Units	Results
Mass per Unit	ASTM D3776	GSM	61.3
Mass per Unit	ASTM D3776	oz/yd ²	1.81
Breaking Strength, Length	ASTM D5034	lbf	24.3
Breaking Strength, Width	ASTM D5034	lbf	15.5
Elongation, Length	ASTM D5034	%	71.5
Elongation, Width	ASTM D5034	%	80.6
Tearing Strength, Length	ASTM D5733	lbf	11.8
Tearing Strength, Width	ASTM D5733	lbf	6.2
Bursting Strength	ASTM D3787	lbf	20.2
Air Permeability	ASTM D737	ft ³ /ft ²	<0.58
Synthetic Blood Penetration	ASTM F1670		Pass
Motor Oil Penetration	ASTM F1670		Pass
Household Bleach Penetration	ASTM F1670		Pass
Water-Based Paint Penetration	ASTM F1670		Pass
Sodium Hypochlorite 9.5%	ASTM F1670		Pass
Sodium Hydroxide	ASTM F1670		Pass

Microporous Lab Coat

- Microporous film laminate
- Breathable and comfortable
- Protects from dirt, grime and liquid splashes as well as from paints, bleach and blood
- 4-button front
- Elastic wrists
- Serged seams
- For non-hazardous environment applications
- 10/pkg

PROD. NO.	MOD. NO.	Colour	Sizes
V7015650	2056	White	S-4XL

NEW



Physical Property	Test Method	Units	Results
Mass per Unit	ASTM D3776	GSM	61.3
Mass per Unit	ASTM D3776	oz/yd ²	1.81
Breaking Strength, Length	ASTM D5034	lbf	24.3
Breaking Strength, Width	ASTM D5034	lbf	15.5
Elongation, Length	ASTM D5034	%	71.5
Elongation, Width	ASTM D5034	%	80.6
Tearing Strength, Length	ASTM D5733	lbf	11.8
Tearing Strength, Width	ASTM D5733	lbf	6.2
Bursting Strength	ASTM D3787	lbf	20.2
Air Permeability	ASTM D737	ft ³ /ft ²	<0.58
Synthetic Blood Penetration	ASTM F1670		Pass
Motor Oil Penetration	ASTM F1670		Pass
Household Bleach Penetration	ASTM F1670		Pass
Water-Based Paint Penetration	ASTM F1670		Pass
Sodium Hypochlorite 9.5%	ASTM F1670		Pass
Sodium Hydroxide	ASTM F1670		Pass



DISPOSABLE GARMENTS

Antistatic Microporous Coverall

- Antistatic microporous film laminate
- Breathable and comfortable
- Protects from dirt, grime and liquid splashes as well as from paints, bleach and blood
- Zipper front
- Improved hood and neck design reduces leakage points
- Designed with elastic waist, ankles, and wrists for optimum fit and freedom of movement
- Serged seams
- For non-hazardous environment applications
- Individually packed



PROD. NO.	MOD. NO.	Colour	Sizes
V7016550	2065	White	S-5XL

NEW

Physical Property	Test Method	Units	Results
Mass per Unit	ASTM D3776	GSM	61.3
Mass per Unit	ASTM D3776	oz/lyd ²	1.81
Breaking Strength, Length	ASTM D5034	lbf	24.3
Breaking Strength, Width	ASTM D5034	lbf	15.5
Elongation, Length	ASTM D5034	%	71.5
Elongation, Width	ASTM D5034	%	80.6
Tearing Strength, Length	ASTM D5733	lbf	11.8
Tearing Strength, Width	ASTM D5733	lbf	6.2
Bursting Strength	ASTM D3787	lbf	20.2
Air Permeability	ASTM D737	ft ³ /ft ²	<0.58
Synthetic Blood Penetration	ASTM F1670		Pass
Motor Oil Penetration	ASTM F1670		Pass
Household Bleach Penetration	ASTM F1670		Pass
Water-Based Paint Penetration	ASTM F1670		Pass
Sodium Hypochlorite 9.5%	ASTM F1670		Pass
Sodium Hydroxide	ASTM F1670		Pass
Electrostatic Surface Resistance	EN1149	ohm	2.8x10 ⁹
Electrostatic Surface Resistivity	EN1149	ohm	5.5x10 ¹⁰

Polypropylene Bouffant Cap

- Basis weight 12 GSM tested ASTM D3776
- Highly breathable, cool and comfortable
- Protection from dust, dirt and grime, oil and grease
- For non-hazardous environment applications
- 100/pkg

PROD. NO.	MOD. NO.	Colour	Sizes
V7012150	2021	White	21" fits most
V7012140	2021B	Blue	21" fits most

NEW
NEW



Polypropylene Shoe Cover

- Basis weight 30 GSM tested ASTM D3776
- Lightweight, economy and disposable
- Elastic ankles
- For non-hazardous environment applications
- 50 pairs/pkg

PROD. NO.	MOD. NO.	Colour	Sizes
V7012250	2022	White	17.3" x 7.1" fits most

NEW



Polypropylene Boot Cover

- Basis weight 30 GSM tested ASTM D3776
- Lightweight, economy and disposable
- Elastic ankles
- Serged seams
- Anti-skid design
- For non-hazardous environment applications
- 25 pairs/pkg

PROD. NO.	MOD. NO.	Colour	Sizes
V7012350	2023	Blue	17" fits most

NEW







FOOTWEAR

**STRIDES
AHEAD IN
SAFETY AND
COMFORT**



LEATHER BOOTS

Leather 6" Work Boot

- CSA Class 1 steel toe/steel plate with bumper toe cap
- CSA Omega electric shock resistant
- Thermolite® thermal barrier
- Double density, oil-resistant PU sole
- Superior comfort and fit

PROD. NO.	MOD. NO.	Colour	Sizes
V4610170	1025	Black	7-11 (half sizes), 12-14
V4610130	1026	Brown	7-11 (half sizes), 12-14



Leather 8" Work Boot

- CSA Class 1 steel toe/steel plate with bumper toe cap
- CSA Omega electric shock resistant
- Thermolite® thermal barrier
- Double density, oil-resistant PU sole
- Superior comfort and fit

PROD. NO.	MOD. NO.	Colour	Sizes
V4610370	1027	Black	7-11 (half sizes), 12-14
V4610330	1028	Brown	7-11 (half sizes), 12-14



Leather 6" Work Boot

- CSA Class 1 steel toe/steel plate
- CSA Omega electric shock resistant
- Flex-Lite design
- Dust-proof tongue

PROD. NO.	MOD. NO.	Colour	Sizes
V4610570	1031	Black	7-14 (half sizes 8.5, 9.5, 10.5)
V4610530	1032	Brown	7-14 (half sizes 8.5, 9.5, 10.5)



Leather 8" Work Boot

- CSA Class 1 steel toe/steel plate
- CSA Omega electric shock resistant
- Flex-Lite design
- Dust-proof tongue

PROD. NO.	MOD. NO.	Colour	Sizes
V4610770	1033	Black	7-14 (half sizes 8.5, 9.5, 10.5)
V4610730	1034	Brown	7-14 (half sizes 8.5, 9.5, 10.5)

LEATHER BOOTS



Composite Toe/Plate Metal-Free Leather Safety Work Boot

- Premium full-grain 2.0 mm waterproof leather upper
- Waterproof/breathable design
- CSA Class 1 composite toe and plate
- CSA Omega shock resistant
- Thermolite® insulation
- Metal-free construction
- Dual density oil-resistant PU sole
- Removable polyurethane comfort insole
- Dura nylon 1200 Denier breathable sidewalls
- TPU protective toe cap



PROD. NO.	MOD. NO.	Colour	Sizes
V4610870	1050	Black	7-11 (half sizes), 12-14
V4610830	1051	Brown	7-11 (half sizes), 12-14

PVC BOOTS

PVC Plain Toe Boot

- Generous, comfortable fit
- Durable and flexible PVC shaft
- Heavy-duty PVC compounded sole
- Puncture- and tear-resistant
- 2 cut-off lines for shorter boot formats



PROD. NO.	MOD. NO.	Colour	Sizes
V4710170	1011	Black	3-13

PVC Steel Toe/Plate Boot

- CSA Class 1 steel toe/steel plate
- Static dissipative
- Generous, comfortable fit
- Durable and flexible PVC shaft
- Heavy-duty PVC compounded sole
- Puncture- and tear-resistant
- 2 cut-off lines for shorter boot formats



PROD. NO.	MOD. NO.	Colour	Sizes
V4710270	1022	Black	3-13





PVC BOOTS

Bully Steel Toe/Plate Boot

- CSA Class 1 steel toe/steel plate
- Premium quality
- GelFlex® shock-absorbing heel and midsole
- UltraFlex oil- and acid-resistant compound
- Removable moulded insole



PROD. NO.	MOD. NO.	Colour	Sizes
V4710580	9679	Navy	7-14



SurStik Plain Toe Boot

- Plain toe
- GelFlex® shock-absorbing heel and midsole
- UltraFlex oil- and acid-resistant compound
- Advanced SurStik slip resistant sole
- Removable moulded insole



PROD. NO.	MOD. NO.	Colour	Sizes
V4710680	9685	Navy	7-14



Plain Toe Hip Wader

- Canvas upper with heavy-duty .65 mm PVC coating
- PVC/nitrile outsole
- High-frequency heat-sealed for 100 % waterproof seams
- Waist straps
- Chemical resistant
- Slip-resistant tread pattern



PROD. NO.	MOD. NO.	Colour	Sizes
V4720170	1040	Black	7-13

Steel Toe/Plate Hip Wader

- CSA Class 1 steel toe/steel plate
- Static dissipative
- Canvas upper with heavy-duty .65 mm PVC coating
- PVC/nitrile outsole
- High-frequency heat-sealed for 100 % waterproof seams
- Waist straps
- Chemical resistant



PROD. NO.	MOD. NO.	Colour	Sizes
V4720370	1042	Black	8-13

Plain Toe Chest Wader

- Canvas upper with heavy-duty .65 mm PVC coating
- Adjustable elastic suspenders
- Adjustable drawstring/toggle waist, front chest pouch
- PVC/nitrile outsole
- High-frequency heat-sealed for 100 % waterproof seams
- Waist straps
- Chemical resistant
- Slip-resistant tread pattern



PROD. NO.	MOD. NO.	Colour	Sizes
V4720270	1041	Black	7-13

Steel Toe/Plate Chest Wader

- CSA Class 1 steel toe/steel plate
- Static dissipative
- Canvas upper with heavy-duty .65 mm PVC coating
- Adjustable elastic suspenders
- Adjustable drawstring/toggle waist, front chest pouch
- PVC/nitrile outsole
- High-frequency heat-sealed for 100 % waterproof seams
- Waist straps
- Chemical resistant



PROD. NO.	MOD. NO.	Colour	Sizes
V4720470	1043	Black	8-13





CANADA'S PREMIUM POLYURETHANE BOOT

NEW

COLD WEATHER
-50°C



RANPRO BOOTS

Ranpro Ultra -50°C Composite Toe/Plate PU Boot

- Rated for -50°C
- Composite toe and non-metallic midsole provides full safety protection and increased thermal insulation in cold weather
- Omega/EH rated
- Winter tire inspired tread pattern features wider and deeper dispersion lines designed to pull water up and away from the contact point between the sole and ground for greater slip resistance
- Aggressive tread design to provide superior traction in snow and mud
- Reinforced ankle protection and extra ankle room to prevent rubbing
- Upper grip on boot allows you to easily pull on boots even when wet or muddy
- Ergonomically designed upper boot to allow for a better range of movement at the calf
- Lightweight and comfortable
- Innovative heel-tab for easy removal
- Cut-off line for customizable boot height
- Mineral, organic and chemical resistant



PROD. NO.	MOD. NO.	Colour	Sizes
V4240140	B105FUL.GR	Green	6-15

NEW

Ranpro Steel Toe/Plate PU Boot

- Steel toe and mid-sole
- Mineral, organic and chemical resistant
- Lightweight and extremely comfortable
- Innovative heel-tab for easy removal
- Reinforced ankle protection and extra ankle room to prevent rubbing
- Upper grip on boot allows you to easily put on boots
- Cut-off line for customizable boot height
- Ergonomically designed upper boot to allow for a better range of movement at the calf
- Water channeling tire tread-inspired soles
- Non-clogging sole
- Rated to -20°C



PROD. NO.	MOD. NO.	Colour	Sizes
V4240640	B405FUL.GR	Green	4-15
V4240360	B405FUL.YL	Yellow	4-15
V4240500	B405FUL.WH	White	4-15



Ranpro Plain Toe PU Boot

- Same great features as above, but in a non-steel toe/mid-sole version
- Soft toe used in applications where foot safety is not at risk



PROD. NO.	MOD. NO.	Colour	Sizes
V4240440	B405SOF.GR	Green	4-15





SAFETY SHOES

Low-Cut Metal-Free Safety Hiker/Warehouse Shoe

- CSA Class 1 composite toe/plate
- CSA Omega electric shock resistant to 18 kV
- Premium, lightweight, metal-free construction
- Contender 88 composite safety toe cap
- Wellmax Flex-05 non-metallic safety sole plate
- Breathable, moisture-wicking nylon mesh lining
- Removable moulded EVA footbed
- Comfortable cushioning Phylon midsole
- Slip-, oil- and wear-resistant Havoc rubber outsole
- Meets BS EN ISO 13287:2007 standard for sole slip resistance
- Upper features breathable nylon mesh panels
- Safety reflective stripe design
- Durable microfibre vamp, quarter and heel



PROD. NO.	MOD. NO.	Colour	Sizes
V4810170	1098	Black	7, 8 to 10.5 (half sizes), 11 to 15

NEW

SOCKS AND SOCKETTES

Radiantex® Insole

- Dual layer warm felt design
- First layer 510 g grey felt polypro/polyester and acrylic fibres
- Second layer 510 g white polypro fibres
- Layers needle-punched together with a Radiantex® metallic heat-reflecting film
- 6 pr/pkg



PROD. NO.	MOD. NO.	Colour	Sizes
V4800510	P411	Grey	6-13



Pioneer Boot Sockette

- 2-layer thermo system: outside cotton to absorb moisture and inside acrylic fleece for insulation
- Elastic ankle for good fit
- Reinforced heel
- For all rubber, plastic and work boots



PROD. NO.	MOD. NO.	Colour	Sizes
V4800410	P305	Green	4, 6, 8, 10, 12, 14



De Claremont® Boot Sockette

- 3 layers for sturdiness, warmth and moisture wicking
- Absorbs foot perspiration
- For all rubber, plastic and work boots



PROD. NO.	MOD. NO.	Colour	Sizes
V4800110	120	Grey	7, 9, 11, 12

SOCKS AND SOCKETTES



Acrylic Blend Sock 3-Pack

- Thermal acrylic blend (80% acrylic, 20% nylon)



PROD. NO.	MOD. NO.	Colour	Sizes
V4800290	123	Black, Navy and Brown 3-pack	Fit-All



Thermal Wool Blend Sock

- Thermal wool blend (5% wool, 90% polyester, 5% elastane)
- Warm terry knit
- Extra long leg and cuff
- 1 dz/pkg



PROD. NO.	MOD. NO.	Colour	Sizes
V4800370	124B	Black Mix	Fit-All





WELDING APPAREL

**FUSING SAFETY,
QUALITY AND
DURABILITY**

Econoweld Jacket

- T-90 5-ply Kevlar® seams for increased durability
- Riveted stress points and reinforced snaps for durability
- Soap stone shoulder pocket
- Fully adjustable waist, cuffs and collar
- 30" length • Green supple side-split leather
- Exclusive lined shoulder for freer movement, less fatigue and easier on and off
- Leather inner pocket

PROD. NO.	MOD. NO.	Colour	Sizes
V2340720	WJ 100	Green	S-3XL



Rebel Welding Jacket

- T-90 5-ply Kevlar® seams for increased durability
- Riveted stress points and reinforced snaps for durability
- Soap stone shoulder pocket
- Fully adjustable waist, cuffs and collar
- 30" length • Grey side-split leather front
- FR cotton back for breathable comfort

PROD. NO.	MOD. NO.	Colour	Sizes
V2340620	WJ 250	Pearl	M-3XL



Welding Jacket

- T-90 5-ply Kevlar® seams for increased durability
- Riveted stress points and reinforced snaps for durability
- Soap stone shoulder pocket • Fully adjustable waist, cuffs and collar
- 27" length • Pearl grey side-split leather

PROD. NO.	MOD. NO.	Colour	Sizes
V2340500	WJ 150	Pearl	M-3XL



Bib Apron

- Double lock stitching with T-90 5-ply Kevlar® seams
- Green supple side-split leather
- Riveted reinforcements at stress points • 36" long
- Front accessories bib pocket • Dual D-rings at waist
- Wide adjustable suspenders with self-balancing spreader bar for maximum comfort
- Quick-release buckle

PROD. NO.	MOD. NO.	Colour	Sizes
V2340120	AP 100	Green	Fit-All



Waist Apron

- 24" long • Wide adjustable belt system with quick-release buckle

PROD. NO.	MOD. NO.	Colour	Sizes
V2340240	AP 200	Green	Fit-All





ranpro

CS 100



BIB 100



WELDING APPAREL ACCESSORIES

Welding Cape Sleeves and Bib

- CS 100:
- Exclusive lined shoulder for ease of movement, less fatigue and easier on and off
- Fully adjustable cuffs and collar
- Cool, open back design
- Soap stone shoulder pocket
- Snaps to attach to bib (BIB 100, sold separately)
- BIB 100:
- Heat and spark resistant
- Adjustable waist strap with quick-release buckle
- Snaps to attach to cape sleeves (CS 100, sold separately)

PROD. NO.	MOD. NO.	Colour	Sizes
V2340440	CS 100	Green	M-2XL
V2340340	BIB 100	Green	M-2XL

Waist Pant

- Green supple side-split leather
- Double lock stitched
- Wide adjustable suspenders with self-balancing spreader bar for maximum comfort
- Quick-release buckle
- Ring for rod holder
- Snap front fly

PROD. NO.	MOD. NO.	Colour	Sizes
V2340840	WP 100	Green	M-2XL

Sleeve Set

- 23" long
- Sold in pairs
- Protects arms and front of shoulders
- Comfortable easy-moving strap system for around the neck
- Adjustable cuffs for best fit

PROD. NO.	MOD. NO.	Colour	Sizes
V2340920	SL 100	Green	Fit-All

Rod Holder

- Heat-resistant rugged side-split cowhide
- Kevlar® stitched
- Reinforcing rivets at stress points

PROD. NO.	MOD. NO.	Colour	Sizes
V6241840	RH 100	Green	Fit-All

Legging

- 14" upper
- Pearl grey heat-resistant rugged side-split cowhide
- Hook and loop closure
- Shin protector
- Wool lined
- Adjustable metal stay in flare
- Reinforcing rivets at stress points

PROD. NO.	MOD. NO.	Colour	Sizes
V2349820	63058	Pearl Grey	Fit-All



Spat

- 6" spat
- Pearl grey heat-resistant rugged side-split cowhide
- Hook and loop closure, elastic instep
- Kevlar® stitched for durability
- Reinforcing rivets at stress points

PROD. NO.	MOD. NO.	Colour	Sizes
V2349020	SP5	Pearl Grey	Fit-All



WELDING GLOVES AND MITTS

Classic Heavy Duty Glove

- Lined back
- Heat-resistant side-split back and palm
- Straight thumb with strap
- T-80 4-ply Kevlar® stitched for strength and durability

PROD. NO.	MOD. NO.	Colour	Sizes
V5241540	799L	Green	Fit-All



Classic Heavy Duty Mitt

- One-finger mitt
- Lined backs
- Heat-resistant side-split back and palm
- T-80 4-ply Kevlar® stitched for strength and durability

PROD. NO.	MOD. NO.	Colour	Sizes
V5241440	777L	Green	Fit-All



Huskies Light Duty Glove

- One-piece back
- Wing thumb

PROD. NO.	MOD. NO.	Colour	Sizes
V5240820	341S	Russet	Fit-All (small)
V5241220	341	Russet	Fit-All (reg.)



Huskies Light Duty Mitt

- One-finger mitt
- One-piece back
- Wing thumb

PROD. NO.	MOD. NO.	Colour	Sizes
V5241120	312	Russet	Fit-All





WELDING GLOVES AND MITTS

Coyote Light Duty Glove

- One-piece back • Wing thumb

PROD. NO.	MOD. NO.	Colour	Sizes
V5240020	251	Russet (may vary)	Fit-All

Super Tiggers TIG Glove

- Rugged glove provides exceptional comfort, flexibility and durability
- Deer grain palm, thumb and forefinger • Split leather back
- 4" pearl cuff • T-50 3-ply Kevlar® stitched for strength

PROD. NO.	MOD. NO.	Colour	Sizes
V5241820	858	Yellow & Green	Fit-All

White Stags TIG Glove

- Rugged glove provides exceptional comfort, flexibility and durability
- Soft full grain calf • 4" pearl cuff
- T-50 3-ply Kevlar® stitched for strength • Snug fit

PROD. NO.	MOD. NO.	Colour	Sizes
V5241620	852	Pearl	S, M, L, XL

Tiggers TIG Glove

- Pearl grain calf palm, thumb and forefinger • Split leather back
- 4" pearl cuff • T-50 3-ply Kevlar® stitched for strength

PROD. NO.	MOD. NO.	Colour	Sizes
V5241720	856	Pearl & Green	M, L

High Heat Aluminized/Leather Combo Mitt

- 13" two-finger mitt with thumb strap
- Ideal for extremely hot welding jobs, pouring, handling castings and cores
- Excellent for arc and other high reflected heat applications
- Thermofom-lined for added insulation against heat
- Rugged, high heat-resistant side split cowhide leather outer shell
- Generous sizing allows for better cooling
- Heat-reflective aluminized and insulated back with heat-resistant side split leather palm
- T-80 4-ply Kevlar® stitched for strength

PROD. NO.	MOD. NO.	Colour	Sizes
V5240430	695FL	Red	Fit-All

Aluminized Hand Shield

- 8"x6" hand shield • Aluminized fibreglass with heavy insulated leather lining
- Elasticized leather straps to fit over most gloves

PROD. NO.	MOD. NO.	Colour	Sizes
V5240130	HS 366	Grey	Fit-All

High Heat Leather Glove, Foam Lined

- 13" glove with one-piece back, thumb strap and cuff protector
- Ideal for extremely hot welding jobs, pouring, handling castings and cores
- Thermofoam-lined for added insulation against heat
- Rugged, high heat-resistant side split cowhide leather outer shell
- Generous sizing allows for better cooling
- Interior FR air cushion and FR cotton lining
- T-80 4-ply Kevlar® stitched for strength

PROD. NO.	MOD. NO.	Colour	Sizes
V5240330	667L	Red	Fit-All



Welder's Cowgrain Glove

- Beige cowgrain palm
- Gold cowsplit back
- By dozen or 6 dz/pkg

PROD. NO.	MOD. NO.	Colour	Sizes
V5050100	542	Beige/Gold	M-XL



Welder's Cowgrain Glove

- Beige cowgrain palm
- Grey cowsplit back
- Kevlar® stitching
- By dozen or 10 dz/pkg

PROD. NO.	MOD. NO.	Colour	Sizes
V5050200	5441	Beige/Gold	M-XL



Welder's Cowsplit Glove

- Grey cowsplit palm
- Gold cowsplit back
- Cotton lined
- Kevlar® stitching
- By dozen or 6 dz/pkg

PROD. NO.	MOD. NO.	Colour	Sizes
V5050300	844	Grey/Gold	M-XL



Fleece Lined Welder's Cowsplit Glove

- Grey cowsplit
- Fleece-lined palm, fingers and thumb
- Navy cotton lined 14" cuff, hemmed in self fabric
- By dozen or 6 dz/pkg



PROD. NO.	MOD. NO.	Colour	Sizes
V5050500	830	Grey	M-2XL







GLOVES

**SAFETY
IN YOUR
HANDS**

833



SEAMLESS KNIT LATEX GLOVES

Seamless Knit Latex Glove

- Crinkle palm
- Black thermal knit
- Black latex coated palm
- By dozen or 6 dz/pkg

PROD. NO.	MOD. NO.	Colour	Sizes
V5010170	5311	Black	S-XL



Seamless Knit Latex Glove

- Crinkle palm
- Brushed thermal knit
- Black latex coated palm
- By dozen or 6 dz/pkg

PROD. NO.	MOD. NO.	Colour	Sizes
V5010260	5322	Hi-Viz Yellow/Green	S-XL



Seamless Knit Latex Glove

- Crinkle palm
- Charcoal recycled poly/cotton knit
- Blue latex coated palm
- By dozen or 10 dz/pkg

PROD. NO.	MOD. NO.	Colour	Sizes
V5010340	5330	Grey	S-XL



Seamless Knit Criss-Cross Nylon Glove

- Crinkle palm
- 100 % nylon knit
- PVC criss-cross
- By dozen or 10 dz/pkg

PROD. NO.	MOD. NO.	Colour	Sizes
V5010650	544	Orange	S-XL

SEAMLESS KNIT LATEX GLOVES



Seamless Knit Latex Glove

- Crinkle palm
- Grey polyester knit
- Blue latex coated palm
- By dozen or 10 dz/pkg

PROD. NO.	MOD. NO.	Colour	Sizes
V5010440	5333	Grey	S-XL



Double Nitrile Seamless Knit Winter Grip Glove

- Unique double nitrile palm coating: inner nitrile layer for oil/chemical protection, outer sand nitrile finish for gripping power
- 2-layer insulated liner provides warmth and flexibility: inner warm soft brushed acrylic liner, outer seamless stretch liner
- Glove design soft and flexible to -50°C
- Insulated comfort, grip, dexterity, and oil/chemical resistance
- Hang carded with UPC
- 1 dz/pkg



PROD. NO.	MOD. NO.	Colour	Sizes
V5010560	5355	Hi-Viz Yellow/Green	M-XL



FITTER'S, ROPER'S AND DRIVER'S COWGRAIN GLOVES

Fitter's Cowgrain Glove

- One-piece palm
- Outside elastic, rubberized cuff
- By dozen or 10 dz/pkg



531W

PROD. NO.	MOD. NO.	Colour	Sizes
V5020100	531	Yellow Back	L
V5020200	531W	Yellow Back	Women's L



Fitter's Cowgrain Glove

- One-piece palm
- 536U - Unlined
- Inside elastic, rubberized cuff
- By dozen or 10 dz/pkg

PROD. NO.	MOD. NO.	Colour	Sizes
V5020400	536	Yellow Stripe Back	L
V5021000	536U	Yellow Stripe Back	L





Fitter's Cowgrain Glove

- Patch palm
- Inside elastic, rubberized cuff
- By dozen or 10 dz/pkg

PROD. NO.	MOD. NO.	Colour	Sizes
V5020900	536P	Yellow Stripe Back	L



Fitter's Cowgrain Glove

- One-piece palm
- 537U - Unlined
- Outside elastic, polyethylene cuff
- By dozen or 10 dz/pkg

PROD. NO.	MOD. NO.	Colour	Sizes
V5021100	537	Yellow Stripe Back	L
V5021500	537XL	Yellow Stripe Back	XL
V5021400	537U	Yellow Stripe Back	L



Fitter's Cowgrain Glove

- One-piece palm
- 836U - Unlined
- 4.5" cuff
- Outside elastic, rubberized cuff
- By dozen or 10 dz/pkg

PROD. NO.	MOD. NO.	Colour	Sizes
V5022400	836	Yellow Stripe Back	L
V5022500	836U	Yellow Stripe Back	L



Hi-Viz Fitter's Cowgrain Glove

- StarTech™ reflective tape
- One-piece palm
- Inside elastic, rubberized cuff
- By dozen or 10 dz/pkg

PROD. NO.	MOD. NO.	Colour	Sizes
V5020500	536HVO	Hi-Viz Orange Back	L
V5020700	536HVG	Hi-Viz Yellow/Green Back	L

FITTER'S, ROPER'S AND DRIVER'S COWGRAIN GLOVES



Roper's Cowgrain Glove

- Snap back
- By dozen or 10 dz/pkg

PROD. NO.	MOD. NO.	Colour	Sizes
V5021700	543	Beige	S-XL



Driver's Cowgrain Glove

- Unlined
- Inside elastic
- By dozen or 10 dz/pkg

PROD. NO.	MOD. NO.	Colour	Sizes
V5020300	535	Beige	S-XL



MECHANIC'S GLOVES

Mechanic's Style Ergonomic Glove

- Gold goatgrain one-piece palm
- Hang carded with UPC
- 1 dz/pkg

PROD. NO.	MOD. NO.	Colour	Sizes
V5040700	890	Black Spandex Back	S-XL



Mechanic's Style Thinsulate® Lined Ergonomic Glove

- Gold goatgrain one-piece palm
- Thinsulate® lined
- Hang carded with UPC
- 1 dz/pkg



PROD. NO.	MOD. NO.	Colour	Sizes
V5040900	891	Black Spandex Back	S-XL





FITTER'S COWSPLIT GLOVES

Fitter's Cowsplit Glove

- Grey industrial grade cowsplit one-piece palm
- Inside elastic, rubberized cuff
- By dozen or 10 dz/pkg

PROD. NO.	MOD. NO.	Colour	Sizes
V5022200	555	Green Stripe Back	L



Fitter's Cowsplit Glove

- Grey cowsplit blue double palm
- Inside elastic, rubberized cuff
- By dozen or 6 dz/pkg

PROD. NO.	MOD. NO.	Colour	Sizes
V5022000	545	Yellow Back	L



Fitter's Cowsplit Glove

- Grey superior grade cowsplit one-piece palm
- Inside elastic, rubberized cuff
- By dozen or 10 dz/pkg

PROD. NO.	MOD. NO.	Colour	Sizes
V5022100	547	Yellow Stripe Back	L

FITTER'S COWSPLIT GLOVES



Fitter's Cowsplit Glove

- Grey cowsplit blue double palm
- Inside elastic, rubberized cuff
- By dozen or 6 dz/pkg

PROD. NO.	MOD. NO.	Colour	Sizes
V5022600	845	Green Stripe Back	L



Fitter's Cowsplit Glove

- Grey cowsplit patch palm
- Inside elastic, pasted cuff
- By dozen or 10 dz/pkg

PROD. NO.	MOD. NO.	Colour	Sizes
V5022300	834	Blue Stripe Back	L





KNIT LINERS

Jersey Knit Wrist Glove

- Unlined
- By dozen or 25 dz/pkg

PROD. NO.	MOD. NO.	Colour	Sizes
V5060100	525	Brown	L

Salt and Pepper Glove

- Poly/cotton jersey
- Knit wrist
- By dozen or 25 dz/pkg

PROD. NO.	MOD. NO.	Colour	Sizes
V5060200	533	Salt and Pepper	L



Cotton Jersey Knit Wrist Glove

- 7 oz (237 GSM)
- By dozen or 25 dz/pkg

PROD. NO.	MOD. NO.	Colour	Sizes
V5060500	551	Natural	L



Knitted Poly/Cotton Liner

- 17.5 oz (600 GSM)
- By dozen or 25 dz/pkg

PROD. NO.	MOD. NO.	Colour	Sizes
V5060300	540	White	S-XL



Knitted Poly/Cotton Liner

- 17.5 oz (600 GSM)
- By dozen or 25 dz/pkg

PROD. NO.	MOD. NO.	Colour	Sizes
V5060400	541	Natural	S-XL



Nylon Knit Glove

- 100 % nylon
- By dozen or 20 dz/pkg

PROD. NO.	MOD. NO.	Colour	Sizes
V5060700	568	White	S-XL



Nylon/Poly Knit Glove

- 70% nylon, 30% polyester
- By dozen or 20 dz/pkg

PROD. NO.	MOD. NO.	Colour	Sizes
V5060820	5688	White	S-XL





KNIT LINERS

Knitted Cotton/Poly Glove, Dots on Palm

- 65% cotton, 35% polyester
- 16 oz (550 GSM) liner
- Black 150 g PVC dots on palm
- By dozen or 24 dz/pkg

PROD. NO.	MOD. NO.	Colour	Sizes
V5060910	501	Unbleached	S-XL



Knitted Cotton/Poly Glove, Dots on Palm

- 65% cotton, 35% polyester
- 16 oz (550 GSM) liner
- Black 150 g PVC dots on palm
- By dozen or 24 dz/pkg

PROD. NO.	MOD. NO.	Colour	Sizes
V5060920	502	White	S-XL



Knitted Cotton/Poly Glove, Dots on Both Sides

- 65% cotton, 35% polyester
- 16 oz (550 GSM) liner
- Black 300 g PVC dots on palm and back
- By dozen or 24 dz/pkg

PROD. NO.	MOD. NO.	Colour	Sizes
V5060930	503	Unbleached	S-XL



Knitted Cotton/Poly Glove, Dots on Both Sides

- 65% cotton, 35% polyester
- 16 oz (550 GSM) liner
- Black 300 g PVC dots on palm and back
- By dozen or 24 dz/pkg

PROD. NO.	MOD. NO.	Colour	Sizes
V5060940	504	White	S-XL

PVC GLOVES



PVC Glove

- Knit wrist
- By dozen or 10 dz/pkg

PROD. NO.	MOD. NO.	Colour	Sizes
V5070160	556	Yellow	L



PVC 12" Gauntlet Glove

- 12" gauntlet
- By dozen or 10 dz/pkg

PROD. NO.	MOD. NO.	Colour	Sizes
V5070260	558	Yellow	L



PVC 14" Gauntlet Glove

- 14" gauntlet
- By dozen or 10 dz/pkg

PROD. NO.	MOD. NO.	Colour	Sizes
V5070360	559	Yellow	L



PVC Double-Dip 14" Gauntlet Glove

- 14" gauntlet
- Sandy finish
- By dozen or 10 dz/pkg

PROD. NO.	MOD. NO.	Colour	Sizes
V5070400	659	Green	L





PVC GLOVES

PVC Foam Lined Glove

- Rough pebble finish
- Safety cuff
- By dozen or 6 dz/pkg



PROD. NO.	MOD. NO.	Colour	Sizes
V5070650	846	Orange	L



PVC Foam Lined 12" Gauntlet Glove

- 12" (30.5 cm) gauntlet
- Rough pebble finish
- By dozen or 6 dz/pkg



PROD. NO.	MOD. NO.	Colour	Sizes
V5070750	847	Orange	L



INSULATED FITTER'S AND DRIVER'S COWGRAIN AND PIGGRAIN GLOVES

Insulated Fitter's Cowgrain Glove

- One-piece palm
- Boa lined
- Outside elastic, rubberized cuff
- By dozen or 6 dz/pkg



PROD. NO.	MOD. NO.	Colour	Sizes
V5080100	530B	Yellow Back	L



Insulated Fitter's Cowgrain Glove

- One-piece palm
- Foam lined red flannel
- Outside elastic, polyethylene cuff
- By dozen or 6 dz/pkg



PROD. NO.	MOD. NO.	Colour	Sizes
V5080900	537FLRF	Yellow Back	L

INSULATED FITTER'S AND DRIVER'S COWGRAIN AND PIGGRAIN GLOVES



Insulated Fitter's Cowgrain Glove

- Patch palm
- Fully fleece lined
- Inside elastic, rubberized cuff
- By dozen or 6 dz/pkg



PROD. NO.	MOD. NO.	Colour	Sizes
V5080800	536PL	Yellow Stripe Back	L



Insulated Fitter's Cowgrain Glove

- One-piece palm
- Light fleece lining
- Outside elastic, polyethylene cuff
- By dozen or 6 dz/pkg



536LW

PROD. NO.	MOD. NO.	Colour	Sizes
V5080500	536L	Yellow Back	L
V5080600	536LW	Yellow Back	Women's L



Insulated Fitter's Cowgrain Glove

- One-piece palm
- 100 g Thinsulate® lined
- Outside elastic, rubberized cuff
- By dozen or 6 dz/pkg



PROD. NO.	MOD. NO.	Colour	Sizes
V5081400	632	Yellow Back	L
V5081900	632A	Yellow Back	XL
V5081901	632B	Yellow Back	2XL



Insulated Fitter's Cowgrain Glove

- One-piece palm
- Fully fleece lined
- Knit cuff
- By dozen or 10 dz/pkg



PROD. NO.	MOD. NO.	Colour	Sizes
V5080400	536KN	Green Stripe Back	L





INSULATED FITTER'S AND DRIVER'S COWGRAIN AND PIGGRAIN GLOVES

Insulated Fitter's Piggrain Glove

- Beige piggrain patch palm
- Boa lined
- Inside elastic, rubberized cuff
- By dozen 6 dz/pkg



PROD. NO.	MOD. NO.	Colour	Sizes
V5082000	627PB	Green Back	L

Insulated Fitter's Piggrain Glove

- Beige piggrain patch palm
- Lined
- Inside elastic, rubberized cuff
- By dozen or 6 dz/pkg



PROD. NO.	MOD. NO.	Colour	Sizes
V5082100	6632PT	Blue Back	L



Insulated Driver's Cowgrain Glove

- One-piece palm
- Cowsplit back
- Foam lined red fleece
- Inside elastic
- By dozen or 6 dz/pkg



PROD. NO.	MOD. NO.	Colour	Sizes
V5080200	535FLRF	Beige	S-XL



Insulated Driver's Cowgrain Glove

- One-piece palm
- Cowsplit back
- 100 g Thinsulate® lined
- Inside elastic
- By dozen or 6 dz/pkg



PROD. NO.	MOD. NO.	Colour	Sizes
V5080300	535TL	Beige	S-XL



INSULATED FITTER'S COWSPLIT GLOVES



Insulated Fitter's Cowsplit Glove

- Grey one-piece palm
- Foam lined red flannel
- Outside elastic, rubberized cuff
- By dozen or 6 dz/pkg



PROD. NO.	MOD. NO.	Colour	Sizes
V5081000	555FLRF	Yellow Back	L



Insulated Fitter's Cowsplit Glove

- Blue one-piece palm
- 100 g Thinsulate® lined
- Inside elastic, rubberized cuff
- By dozen or 6 dz/pkg



PROD. NO.	MOD. NO.	Colour	Sizes
V5081200	630	Yellow Back	L



Insulated Fitter's Cowsplit Glove

- Brown one-piece palm
- 100 g Thinsulate® lined
- Inside elastic, rubberized cuff
- By dozen or 6 dz/pkg



PROD. NO.	MOD. NO.	Colour	Sizes
V5081300	631BR	Green Back	L



Insulated Fitter's Cowsplit Glove

- Blue one-piece palm
- Boa lined
- Outside elastic, rubberized cuff
- By dozen or 6 dz/pkg



PROD. NO.	MOD. NO.	Colour	Sizes
V5081600	655	Yellow Back	L





INSULATED FITTER'S COWSPLIT GLOVES

Insulated Fitter's Cowsplit Glove

- Brown one-piece palm
- Boa lined
- Outside elastic, rubberized cuff
- By dozen or 6 dz/pkg

PROD. NO.	MOD. NO.	Colour	Sizes
V5081700	656	Green Back	L

Insulated Fitter's Cowsplit Glove

- Black one-piece palm
- Boa lined
- Inside elastic, rubberized cuff
- By dozen or 6 dz/pkg

PROD. NO.	MOD. NO.	Colour	Sizes
V5081800	658	Red Back	L





NON-APPAREL SAFETY PRODUCTS

THE ROAD TO SAFETY



TRAFFIC SAFETY

Common Features

- Soft, high-quality, injection-moulded PVC
- Hi-viz colour with UV protection
- One-piece design for strength and durability
- Bounce back to shape when run over
- Superior strength and flexibility
- Durable heavy, black rubberized bases
- Stable, wide-body design
- Stackable for easy storage
- 100% recyclable design



18" Premium PVC Flexible Safety Cone

- Factory-attached high-luminance Type 3 band for superior visibility
- 3 lbs (1.36 kg)

PROD. NO.	MOD. NO.	Colour	Height
V6200350	181	Orange	18" (45 cm)

18" Premium PVC Flexible Safety Cone

- No band
- 3 lbs (1.36 kg)

PROD. NO.	MOD. NO.	Colour	Height
V6200450	181P	Orange	18" (45 cm)



12" Premium PVC Flexible Safety Cone

- No band
- 1.32 lbs (0.6 kg)

PROD. NO.	MOD. NO.	Colour	Height
V6200150	180P	Orange	12" (30.5 cm)



28" Premium PVC Flexible Safety Cone

- Factory-attached 4" and 6" high-luminance Type 3 bands for superior visibility
- 7 lbs (3.1 kg)

PROD. NO.	MOD. NO.	Colour	Height
V6200550	183	Orange	28" (70 cm)

28" Premium PVC Flexible Safety Cone

- No bands
- 7 lbs (3.1 kg)

PROD. NO.	MOD. NO.	Colour	Height
V6200650	183P	Orange	28" (70 cm)



Connecting Rod

- Single-side extendable from 3.3 to 7 ft (1 to 2.13 m)
- Durable, lightweight, retractable
- For temporary barricading applications
- Reflective bands for enhanced visibility
- Loops at each end for use with any standard cone

PROD. NO.	MOD. NO.	Colour	Length
V6201010	189	Red and White	3.3-7 ft (1-2.13 m)



T-Top 47" Delineator Post

- High-visibility reflective post
- 2 4-inch high-intensity Type 3 reflective bands at the top of the post
- 2-piece construction for compact storage
- UV inhibitors resist fading
- Top can be used to tie barricade tape or to support standard barricade lights

PROD. NO.	MOD. NO.	Colour	Height
V6210150	191	Orange	47" (119.4 cm)

Loop Top 44" Delineator Post

- High-visibility reflective post
- 2 4-inch high-intensity Type 3 reflective bands at the top of the post
- 2-piece construction for compact storage
- UV inhibitors resist fading
- Easy-carry hand hold on pole bottom
- Top can be used to tie barricade tape or to support standard barricade lights

PROD. NO.	MOD. NO.	Colour	Height
V6210250	192	Orange	44" (111.3 cm)

Delineator Base (sold separately)

- Rubber
- Easy-carry hand hold

PROD. NO.	MOD. NO.	Colour	Weight
V6220170	201	Black	11 lbs (5 kg)
V6220270	202	Black	13.2 lbs (6 kg)
V6220370	203	Black	17.6 lbs (8 kg)





TRAFFIC SAFETY

Double-Sided Wheel Chock

- For loading dock safety
- Rugged rubber with safe, secure grip
- Resilient rubber compound reinforced for maximum wearability and strength
- Traditional eyebolt for sturdy security chain connection
- 9 lbs (4 kg)

PROD. NO.	MOD. NO.	Colour	Dimensions, LxWxH
V6220870	298	Black	9.75" x 8" x 6" (248 cm x 203 cm x 152 cm)

NEW



Barricade Light

- Can be used with delineator post, traffic drum or A-frame barricade using 175B bolt in middle of battery holder
- Tough 7" polycarbonate lens with advanced optics for increased visibility
- Tamper-proof switch
- On at dusk, off at dawn photo sensor
- Two settings, steady on or flashing
- LED flashing rate of 65 times per minute
- 360° swivel head
- Uses 2 4R25 6V lantern batteries (not included)

PROD. NO.	MOD. NO.	Colour	Sizes
V6020260	177	Yellow	O/S



Barricade Light

- Can be used with delineator post, traffic drum or A-frame barricade using 175B bolt in middle of battery holder
- 7" standard lens with advanced optics for increased visibility
- Tamper-proof switch
- On at dusk, off at dawn photo sensor
- Two settings, steady on or flashing
- LED flashing rate of 65 times per minute
- 360° swivel head
- Uses 4 D-cell batteries (not included)

PROD. NO.	MOD. NO.	Colour	Sizes
V6020360	176	Yellow	O/S



Extra-Long 4.5" Bolt

- For attaching barricade lights to delineator posts and barricades

PROD. NO.	MOD. NO.	Length
V6020900	175B	4.5" (11.4 cm)

Bilingual Janitorial Floor Sign

- Black safety messages on both sides
- 301 - CAUTION WET FLOOR/ATTENTION PLANCHER MOUILLÉ
- 302 - CAUTION/ATTENTION
- Heavy-duty, durable, reinforced design
- Deluxe hinge/carry handle
- Easy to deploy A-frame design folds flat for easy storage
- 2.9 lbs (1.3 kg)

PROD. NO.	MOD. NO.	Colour	Dimensions, WxH
V6300160	301	Yellow	12" x 29" (30 cm x 68 cm)
V6300260	302	Yellow	12" x 29" (30 cm x 68 cm)



301

302

Snow/Safety Fence

- 777/778 - Heavy-duty 230 GSM (280 g/lm) extruded polyethylene
- 772 - Heavy-duty 200 GSM (240 g/lm) extruded polyethylene
- Strong, heavy-duty construction resistant to wind and snow
- Engineered to control drifting snow and sand
- Strong and durable, will not rust or corrode
- For highways, driveways, ski areas and winter trails, and for construction, excavation and demolition sites

PROD. NO.	MOD. NO.	Colour	Dimensions, WxH
V6010250	777	Orange	50' x 4' (15.2 m x 1.2 m)
V6010450	778	Orange	100' x 4' (30.5 m x 1.2 m)
V6010150	772	Orange	100' x 4' (30.5 m x 1.2 m)

NEW



3-Channel Cable Protector

V6220490 / 286

- Tough, commercial-grade rubber base construction
- Durable, high-visibility, yellow plastic-hinged lid for easy cable access
- Protects multiple cables from pedestrians and car traffic
- 30-ton capacity
- Channel width: 5.7 cm, can accommodate cables up to 50 mm in diameter

NEW



5-Channel Cable Protector

V6220590 / 287

- Tough, commercial-grade rubber base construction
- Durable, high-visibility, yellow plastic-hinged lid for easy cable access
- Protects multiple cables from pedestrians and car traffic
- 30-ton capacity
- Channel width: 3.5 cm, can accommodate cables up to 35 mm in diameter

NEW





SIZING CHART

Body Measurements (not garment measurements)

Jackets, Coveralls, Overalls																						
	XS		S		M		L		XL		2XL		3XL		4XL		5XL		6XL		7XL	
Size	32	34	36	38	40	42	44	46	48	50	52	54	56	58	60	62	64	66	68	70	72	
Chest	32	34	36	38	40	42	44	46	48	50	52	54	56	58	60	62	64	66	68	70	72	
Waist	26	28	30	32	34	36	38	40	42	44	46	48	50	52	54	56	58	60	62	64	66	
Arms	32	33		34		35		36		37		38		39		40		41		42		
Hip	32	34	36	38	40	42	44	46	48	50	52	54	56	58	60	62	64	66	68	70	72	

Pants (overalls are sized based on chest measurements)																						
	XS		S		M		L		XL		2XL		3XL		4XL		5XL		6XL		7XL	
Size	26	28	30	32	34	36	38	40	42	44	46	48	50	52	54	56	58	60	62	64	66	
Waist	26	28	30	32	34	36	38	40	42	44	46	48	50	52	54	56	58	60	62	64	66	
Hip	32	34	36	38	40	42	44	46	48	50	52	54	56	58	60	62	64	66	68	70	72	
Inseam	30.5		31		31.5		32		32.5		33		33.5		34		34.5		35		35.5	

Shirts (select size by neck for closed collar shirts, by chest for open collar shirts)																				
	S		M		L		XL		2XL		3XL		4XL		5XL		6XL		7XL	
Neck	14-14.5		15-15.5		16-16.5		17-17.5		18-18.5		19-19.5		20-20.5		21-21.5		22-22.5		23-23.5	
Chest	34		38		42		46		50		54		58		62		66		70	
Sleeve	33.5		34		34.5		35		35.5		36		36.5		37		37.5		38	

Women's Garment Sizing												
	XS		S		M		L		XL		2XL	
Chest	32		34		36		39		42		45	
Waist	24		26		28		31		34		37	
Arms	29		30		31		32		33		34	
Hip	35		37		39		42		45		48	
Inseam	27		28		29		30		31		32	

All measurements in inches.

Talls in Coveralls are 2 inches longer in the torso and 1 inch longer in the sleeves and legs.

Measurement Directions:

- Neck:** Measure around the base of your neck, round up to the next half-inch.
- Chest:** Measure around your chest, under the arms and across the shoulder blades, over a shirt if stomach is larger than chest; choose the larger size.
- Waist:** Measure around your waist at the level you normally wear your pants, over a shirt.
- Hip:** Standing with feet together, measure around the widest part of your hips, parallel to the floor.
- Inseam:** Measure a good-fitting pair of pants along the inseam, from crotch seam to bottom edge of cuff.
- Sleeve:** Bend arm and place fist on hip. Measure from centre back of your neck, across shoulder and down arm to elbow and then to your wrist. This is your sleeve length.

For working garments, measure liberally to find your size, as you need freedom of movement.

STAR★TECH™

STARTECH™ reflective tape is exclusive to Pioneer safety products. It is designed and tested to far exceed the CSA Z96-09 high-visibility safety apparel reflective tape standard.



STARTECH™ reflective tape has been independently tested to meet:

- CSA Z96-09 High-Visibility Safety Apparel Standard Level 2
- EN ISO 20471 High-Visibility Standard Level 2
- ANSI/ISEA 107-2010 Level 2

STARTECH™ FR tape is made of FR cotton or aramid material as backing and has been independent lab tested to meet:

- CGSB 155.20-2000 Heat-Resistant Test Par. 6.2.3
- CSA Z96-09 High-Visibility Safety Apparel Standard Level 2

The many standards for reflective tapes all require passing a battery of tests that simulate working conditions.

These include measuring the retroreflective performance of STARTECH™ tape after being subjected to: abrasion, multiple flexing, cold temperatures, variable temperatures, multiple washings, wet conditions, and, for the FR version, its heat resistance properties as well. Due to its premium design and quality, STARTECH™ tape not only meets but exceeds all of these standards!



WARRANTY

Garment and Safety Gear

Pioneer warrants all garments to be free of defects in materials and workmanship under the normal use for which the product is intended. Normally, a garment defect of manufacture will show up in the first two months of use.

This warranty is limited to product failure as a result of seam separation, broken snaps or zippers, material delaminating, or any defect in material or workmanship that affects the performance of the garment.

Excluded from this warranty are products that have been affected by cuts or punctures, disfigured from continued wear or use, and products that have been exposed to solvents or excessive heat which may degrade their performance and garments that have not been maintained as per wash care instructions on the garment.

Warranty claims will only be provided for those products that have been made available for inspection by Pioneer. Any warranty claim on garments that have been purchased over 60 days ago will have to be accompanied by pictures and/ or defective garment itself for inspection. To maintain our health and safety standards, all products returned for inspection must be free of all removable debris. Any products returned that do not meet the above conditions will be returned to the customer at their expense.

Pioneer shall not be liable for indirect, special, incidental, or consequential damage or penalties and does not assume liability of purchaser or others for injury to persons or property.

For a warranty claim on a Pioneer garment, please contact your local sales or customer service representative.

Footwear

Pioneer warrants all Ranpro® boots to be free of defects in materials and workmanship under the normal use for which the product is intended. Normally, a boot defect of manufacture will show up in the first two months of use.

This warranty is limited to product failure as a result of splitting, sole or seam separation, or any defect in material or workmanship that affects the waterproof properties or safety characteristics of the product.

Excluded from this warranty are products that have been affected by cuts or punctures or disfigured from continued wear or use, and products that have been exposed to solvents or excessive heat which may degrade their performance.

Warranty claims are subject to inspection by Pioneer. To maintain our health and safety standards, all products returned need to be cleaned of loose debris and contaminants. Any dirty or contaminated boots will be returned to the customer at their expense.

Pioneer shall not be liable for indirect, special, incidental, or consequential damage or penalties and does not assume liability of purchaser or others for injury to persons or property.

For warranty claims on Pioneer Ranpro® boots, please contact your local sales or customer service representative.





SAFETY AND PRODUCTIVITY

DESIGN

With features like Partially Oriented Yarn shock absorbing lanyards and padded harnesses, our products are designed to keep workers comfortable, safe and secure.

QUALITY

From heavy duty polyester webbing to high grade steel hooks, only the best materials are used in our products.

STANDARDS

Our products meet or exceed CSA, ANSI and many other standards to ensure your safety on the job.

FALL PROTECTION

DID YOU KNOW?

Our team of fall protection experts are members of the committees which develop the standards designed to keep you safe.



PEACE OF MIND

PeakWorks Knows Fall Protection

From its inception in 2008, PeakWorks has been passionate about providing Canadian workers peace of mind when working at heights. The PeakWorks founders, with over 50 years of fall protection experience between them, set out to build a company that not only offered an industry-leading product line, but also provided their customers with value-added services supplying real solutions for both workers and the companies employing them. Today, as an integral part of our family of brands, we embrace those same principles. We know that the best fall protection is to eliminate the fall hazard in the first place. However, we also know that life doesn't always work that way. Our single goal, then, remains very simple: to ensure the best possible outcome when the unexpected occurs.

PeakWorks Embraces Industry Standards

Our in-house fall protection experts are driven to provide the best possible products and systems to ensure maximum worker safety. Like you, we live and work in Canada; and we are intimately knowledgeable about the strict regulations imposed in this country, which has the highest standards in the world. In fact, we are so dedicated to the advancement of worker safety that our fall protection experts are active members of both the CSA and ANSI standards committees. Not only do we adhere to these standards, we help to develop them!

PeakWorks Thrives on Problem Solving

PeakWorks is all about solving problems for workers at height. Our team of experts is available to consult on applications, hazard analysis training, recertification of products and much more. If you need help, we are just a phone call away!

PeakWorks is Proudly Canadian

Did we mention that PeakWorks is a Canadian brand with 100% Canadian focus? That's right. We understand the unique needs of the Canadian fall protection market including regional and national regulations, geographic challenges, and industry-specific requirements. Our entire product portfolio and package of services has been designed to meet or exceed almost every conceivable situation.

PeakWorks Offers Uncompromising Value

Great news! Not only have we developed a world class fall protection program, we have also made every effort to ensure that it is delivered at the best value to you, the customer. We have accomplished this without compromising product quality – your safety remains our primary objective. So give us a call and let us know how PeakWorks can not only exceed your safety expectations, but potentially lower your overall fall protection costs at the same time.

FALL PROTECTION DEFINED

What is Fall Protection?



Fall Protection refers to a series of regulated products or systems designed to protect workers from the risk of falls when working at height.

Types of Fall Protection

There are three basic types of fall protection available on the market:

Fall Restraint – Comprised of products or equipment which prevent a free fall from happening in the first place. The fall restraint system is designed to prevent a worker from ever reaching the edge or drop-off point when working at heights. Common examples: Guard Rails or Restraint Lanyards connected to Full Body Harnesses that are shorter in length than the distance from the Anchor Point to the Drop-Off Point.

Fall Arrest – Comprised of products, equipment or systems which stop a free fall once it occurs. These products are carefully designed and tested to stop a falling worker with minimal risk of injury. Common examples: Full Body Harnesses connected to Shock Absorbing Lanyards, or Self-Retracting Lifelines that are connected to an approved Anchor Point.

Work Positioning – Comprised of products or equipment which support or suspend a worker in order to allow the worker **to be positioned at their working point hands-free**. Common examples: Rebar Chain Assembly, Boatswain's Chairs, Descent Controllers.

Know Your A, B, C's

Fall protection systems are designed to prevent contacting a lower level if you fall from a height. There are several key components to these systems and it is important to know the basics.

A = Anchorage Connectors – The Anchorage is an engineered product which connects to some form of structure. The combination of these two critical components must be capable of withstanding the forces incurred during a fall. In Canada, these components must be capable of withstanding a minimum 5,000 lb (22 kN) of force. Common examples: Anchor Slings, Fixed D-Rings, Beam Anchors, Concrete Hole Anchors, Carabiners.

B = Body Support – The Body Support is the component that is worn on or around the torso. There are two types of Body Support:

Restraint Belt:

Belt that is installed at the waist and used for worker positioning and travel restraint. A Restraint Belt must NEVER be used for fall arrest.

Full Body Harness:

A Full Body Harness is a body support device that is installed on the entire body and is designed to distribute the forces of a fall to the shoulders, thighs and pelvis.

All Full Body Harnesses have a back D-ring designed for the fall arrest connection point. Other styles of Full Body Harnesses are available with other attachment points such as side D-rings for work positioning, a frontal D-ring for ladder climbing, and shoulder D-rings for confined space work. Some styles of harnesses can also have a combination of all or some of these attachment points, for example our Class APLE has the following connection points: (1) back D-ring, (2) side D-rings, (1) frontal D-ring and (2) shoulder D-rings.

Full Body Harnesses are the only accepted body support to be used for a fall arrest application. NEVER use a Restraint Belt in a fall arrest application.

C = Connectors – Connectors are the engineered components that connect the Body Harness or Body Belt to the appropriate Anchorage. Common examples: Shock Absorbing Lanyards, Self-Retracting Lifelines (SRL's), Restraint Lanyards, Lifelines.





PEAKWORKS®

HARNESSES



**SECURING
YOUR PEACE
OF MIND**

863



HARNESSES

Reference Guide

PeakWorks offers three series of harnesses: Compliance, Contractor, and PeakPro.

- Certified to both CSA Z259.10 and ANSI Z359 standards
- Meet or exceed all applicable OSHA standards
- 400-lb (180-kg) capacity (combined weight of person, tools, clothing, etc.)
- Sub-pelvic strap for added safety and support
- Fall indicator for easier inspection before use
- Polyester webbing



Example:
V8001000
(FBH-10002A)

Compliance



- Hi-viz green
- 3 points of adjustment ensuring a good fit (2 leg, 1 chest)
- Buckles: Pass-Thru (chest and legs)



Example:
V8002000
(FBH-10000A)

Contractor



- **Hi-viz green top and black bottom, easily visible and distinguishable for ease of donning**
- **5 points of adjustment ensure a good fit (2 leg, 2 torso, 1 chest)**
- Buckles: Pass-Thru (chest and legs), Pass-Thru or Grommets (legs)



Example:
V8006100
(FBH-60110A)

PeakPro



- Hi-viz green top and black bottom, easily visible and distinguishable for ease of donning
- 5 points of adjustment ensuring a good fit (2 leg, 2 torso, 1 chest)
- **Buckles: premium Stab Lock (chest), Stab Lock (legs) or Grommets (legs)**
- **Padded shoulder, back and leg straps for all-day comfort**



FULL BODY HARNESSES

About Full Body Harnesses



- Full body harnesses are designed to arrest a fall while simultaneously distributing the tremendous shock or load to the worker's body.
- There are many applications and conditions in which full body harnesses must be worn. In order to maximize effectiveness and minimize injury, it is critical that an appropriate body harness be selected based on the job for which it is intended. PeakWorks offers a full range of body harnesses for almost every application.
- Full body harnesses must be fitted and tightened properly to ensure maximum protection and to minimize injury.
- Waist or restraint belts are not replacements for full body harnesses.
- All PeakWorks full body harnesses are built to meet or exceed the highest standards while providing maximum fit and comfort.

Harness Classes

- Full body harnesses come in many styles with a variety of attachment points (D-rings). The placement of these rings is critical to the type of application and positioning of the worker when performing a job.
- The fall protection industry and regulatory committees have standardized the positioning of these attachment rings into Harness Classes A, D, E, L, P.
- Depending on the application, full body harnesses may require more than one attachment class in order to correctly position the body and stress points during a fall, i.e. AE, AL, AP.
- All full body harnesses come with a standard Class A D-ring (located at the back between the shoulder blades).



Class A - Fall Arrest



Class D - Descent



Class E - Limited Access



Class L - Ladder



Class P - Work Positioning

Harness Hardware

- PeakWorks full body harnesses are available with a variety of buckle types for your convenience:



Pass-Thru Chest Strap



Pass-Thru Leg Strap



Grommeted Leg Strap



Stab Lock Chest or Leg Strap



Friction Torso Adjustment



Large Back D-Ring



Padded Back Support



Frontal D-Ring



FULL BODY HARNESSSES

Compliance Series



The PeakWorks Compliance Series harness is the best value on the market. When compliance and price are the keys drivers, this harness is the solution.

- Certified to both CSA Z259.10 and ANSI Z359 standards
- High visibility colour
- 3 points of adjustment ensuring a good fit (2 leg, 1 chest)
- Pass-Thru leg and chest buckles for quick donning
- Sub-pelvic strap for added safety and support
- Fall indicator for easier inspection before use
- Large back D-ring for easy connection
- Meets or exceeds all applicable OSHA standards
- Polyester webbing
- 400-lb (180-kg) capacity (combined weight of person, tools, clothing, etc.)



V8001000
FBH-10002A

PROD. NO.	MOD. NO.	Product Name	Class	Weight	Buckles			D-Ring Location		
					Chest	Leg	Torso	Back	Front	Sides
V8001000	FBH-10002A	Compliance Harness	A	2 lb (0.9 kg)	Pass-Thru	Pass-Thru		1		

FULL BODY HARNESSSES

Contractor Series



The PeakWorks Contractor Series is our most popular harness. With an impressive list of features, this harness offers incredible value.

- Certified to both CSA Z259.10 and ANSI Z359 standards
- High visibility colour
- Two-tone colour scheme for ease of donning
- Fully adjustable for a universal fit
- 5 points of adjustment ensure a good fit (2 leg, 2 torso, 1 chest)
- Pass-Thru leg and chest buckles for quick donning
- Grommeted leg straps available
- Sub-pelvic strap for added safety and support
- Polyester webbing
- Fall indicator for easier inspection before use
- Large back D-ring for easy connection
- Available in a variety of classes: A, AP, AL, AE, APLE
- Meets or exceeds all applicable OSHA standards
- 400-lb (180-kg) capacity (combined weight of person, tools, clothing, etc.)



V8002000
FBH-10000A



V8002210
FBH-10020B



V8002020
FBH-10000L



V8002030
FBH-10000E

PROD. NO.	MOD. NO.	Product Name	Class	Weight	Buckles			D-Ring Location			
					Chest	Leg	Torso	Back	Shoulders	Front	Sides
V8002000	FBH-10000A	Contractor Harness	A	2.5 lb (1.1 kg)	Pass-Thru	Pass-Thru	Friction	1			
V8002010	FBH-10000B	Contractor Harness	AP	3 lb (1.4 kg)	Pass-Thru	Pass-Thru	Friction	1			2
*V8002020	FBH-10000L	Contractor Harness	AL	3.5 lb (1.6 kg)	Pass-Thru	Pass-Thru	Friction	1		1	
V8002030	FBH-10000E	Contractor Harness	AE	3 lb (1.4 kg)	Pass-Thru	Pass-Thru	Friction	1	2		
V8002200	FBH-10020A	Contractor Harness	A	3 lb (1.4 kg)	Pass-Thru	Grommet	Friction	1			
V8002210	FBH-10020B	Contractor Harness	AP	3.5 lb (1.6 kg)	Pass-Thru	Grommet	Friction	1			2
V8002060	FBH-10000J	Contractor Harness	APLE	3.5 lb (1.6 kg)	Pass-Thru	Pass-Thru	Friction	1	2	1	2

* Not certified to ANSI Z359



FULL BODY HARNESSES

PeakPro Series



The PeakWorks PeakPro Series harness is our gold standard harness. With its legendary comfort, this harness can be worn comfortably all day long when working at heights.

- Certified to both CSA Z259.10 and ANSI Z359 standards
- High visibility colour
- Two-tone colour scheme for ease of donning
- Padded shoulder, back and leg straps for all-day comfort
- Fully adjustable for a universal fit
- 5 points of adjustment ensuring a good fit (2 leg, 2 torso, 1 chest)
- Stab Lock leg and chest buckles for quick donning
- Grommated leg straps available
- Sub-pelvic strap for added safety and support
- Fall indicator for easier inspection before use
- Large back D-ring for easy connection
- Available in a variety of classes: A, AP, AL
- Meets or exceeds all applicable OSHA standards
- Polyester webbing
- 400-lb (180-kg) capacity (combined weight of person, tools, clothing, etc.)

NEW Integrated Trauma Strap!



V8006100
FBH-60110A



V8006110
FBH-60110B



V8006120
FBH-60110L



V8006200
FBH-60120A

PROD. NO.	MOD. NO.	Product Name	Class	Weight	Buckles			D-Ring Location			
					Chest	Leg	Torso	Back	Shoulders	Front	Sides
V8006100	FBH-60110A	PeakPro Harness	A	3.5 lb (1.6 kg)	Stab Lock	Stab Lock	Friction	1			
V8006110	FBH-60110B	PeakPro Harness	AP	4 lb (1.8 kg)	Stab Lock	Stab Lock	Friction	1			2
V8006120	FBH-60110L	PeakPro Harness	AL	4 lb (1.8 kg)	Stab Lock	Stab Lock	Friction	1		1	
V8006200	FBH-60120A	PeakPro Harness	A	3.5 lb (1.6 kg)	Stab Lock	Grommet	Friction	1			
V8006210	FBH-60120B	PeakPro Harness	AP	4.5 lb (2 kg)	Stab Lock	Grommet	Friction	1			2

FULL BODY HARNESES

Full Body Harness/Belt Combos



- Lightweight for all-day comfort
- Offered with the Contractor series or PeakPro series harnesses
- Padded lumbar support designed to eliminate any discomfort from the weight of tool pouches
- Waist belt is designed to be removable, so a worker can add their favourite tool pouches with ease
- Positioning belt is designed with 2 side D-rings for any position applications
- Available with traditional Pass-Thru leg strap buckle or with tongue buckle



V825521X
FBH10020A1020-X



V825522X
FBH10000A1020-X



V825562X
FBH60110A1020-X

PROD. NO. (see table below)	MOD. NO.	Size (X)	Product Name	Class	Buckles			D-Ring Location			
					Chest	Leg	Torso	Back	Shoulders	Front	Sides
V825521_	FBH10020A1020-X	S, M, L, XL, XXL	Contractor Harness with Positioning Belt	AP	Pass-Thru	Grommet	Friction	1			2
V825522_	FBH10000A1020-X	S, M, L, XL, XXL	Contractor Harness with Positioning Belt	AP	Pass-Thru	Pass-Thru	Friction	1			2
V825562_	FBH60110A1020-X	S, M, L, XL, XXL	PeakPro Harness with Positioning Belt	AP	Stab Lock	Stab Lock	Friction	1			2
V825564_	FBH10000L1020-X	S, M, L, XL, XXL	Contractor Harness with Positioning Belt	APL	Pass-Thru	Pass-Thru	Friction	1		1	2
V825565_	FBH10000E1020-X	S, M, L, XL, XXL	Contractor Harness with Positioning Belt	APE	Pass-Thru	Pass-Thru	Friction	1	2		2

When ordering a belt, **PROD. NO._** refers to the product size, for example:

Size	PROD. NO.	MOD. NO.
S	V8255211	FBH10020A1020-S
M	V8255212	FBH10020A1020-M
L	V8255213	FBH10020A1020-L
XL	V8255214	FBH10020A1020-XL
XXL	V8255215	FBH10020A1020-XXL

Note: see belt sizing chart on page 870.

BELTS



The PeakWorks series of belts adds versatility and productivity to any PeakWorks harness.

- Lightweight for worker comfort
- Fits all PeakWorks harnesses
- Padded lumbar support made from closed cell foam
- Plated grommets for improved corrosion resistance
- Polyester webbing



Tongue Buckle



D-Ring



V805101X
WB-1010-X



V805601X
WB-6010-X



V8059
WB-6006



V805602X
WB-6020-X

Belt sizing chart:

Size	Min.	Max.
Small	32" (813 mm)	40" (1,016 mm)
Medium	36" (914 mm)	44" (1,118 mm)
Large	42" (1,067 mm)	48" (1,219 mm)
X-Large	44" (1,118 mm)	52" (1,321 mm)
XX-Large	48" (1,219 mm)	56" (1,422 mm)

PROD. NO. (see table below)	MOD. NO.	Size (X)	Product Name	D-Ring Location	
				Back	Sides
V805101_	WB-1010-X	S, M, L, XL, XXL	Restraint Belt	1	
V805601_	WB-6010-X	S, M, L, XL, XXL	PeakPro Restraint Belt with Padded Lumbar Support	1	
V805602_	WB-6020-X	S, M, L, XL, XXL	PeakPro Positioning Belt with Padded Lumbar Support		2
V8059	WB-6006	Universal	Padded Lumbar Support for Belt		

When ordering a belt, **PROD. NO._** refers to the product size, for example:

Size	PROD. NO.	MOD. NO.
S	V8051011	WB-1010-S
M	V8051012	WB-1010-M
L	V8051013	WB-1010-L
XL	V8051014	WB-1010-XL
XXL	V8051015	WB-1010-XXL



PEAKWORKS®

LANYARDS

**CONNECTING
YOU SAFELY**

871



LANYARDS

About Lanyards

- Lanyards are engineered products, and the critical connection component between the full body harness and the anchor. They are sometimes referred to as connectors.
- PeakWorks lanyards are designed and tested to comply to strict CSA and ANSI standards.
- There is a wide variety of lanyards to suit a wide range of applications.
- There are two common types of lanyards: Fall Restraint and Fall Arrest.

Fall Restraint Lanyards

- Fall restraint lanyards are a fixed-length connection and have no shock absorbing capability.
- These lanyards are designed to limit the distance a worker can move from the anchor point and towards the edge of the structure and should never be used when there is a risk of falling.

Fall Arrest Lanyards

- Lanyards for fall arrest applications are designed using two types of shock absorbing technology: POY (Partially Oriented Yarn) and SP (Shock Pack).
- The shock absorbing action of these lanyards limits and reduces the force of a fall on the worker, significantly reducing injury to the body.
- PeakWorks offers both styles of lanyards, POY (Partially Oriented Yarn) and SP (Shock Pack).

POY:

- POY (Partially Oriented Yarn) lanyards are woven in a manner that allows the yarn to stretch out when it has a load applied to it. The POY is encased in tubular webbing for maximum strength.

SP:

- SP (Shock Pack) lanyards are comprised of "tear webbing" which is woven in a manner that allows the webbing to tear when it has a load applied to it. This tearing absorbs a significant amount of downward force under load, reducing injury.
- This tear webbing is folded and shrink-wrapped into a compact 1 x 2 x 6" (2.5 x 5 x 15 cm) pack that is sewn into the lanyard next to the body connector.
- PeakWorks SP lanyards are available in two categories: E4 (worker weight of 100 to 254 lb [45 to 115 kg]) and E6 (worker weight of 200 to 386 lb [90 to 175 kg]).



SHOCK ABSORBING LANYARDS

Partially Oriented Yarn (POY)



PeakWorks Partially Oriented Yarn (POY) shock absorbing lanyards are certified to CSA Z259.11-05 standards.

- Made with a superior grade, heavy-duty tubular polyester outer jacket webbing with POY core
- Resists abrasions and harmful UV rays
- Several models feature extra-large 2-1/2" (64 mm) CSA-approved forged steel hooks
- A full-length internal energy absorber limits the arrest force to 900 lbs (4 kN) maximum
- Several styles are available for use in most field applications
- POY lanyards are available in the E4 category only (worker weight of 100 to 254 lbs [45 to 115 kg])



V810110X
SA-1000-X



V8101116
SA-1040-6



V810112X
SA-1002-X



V810120X
SA-20000-X



V810122X
SA-20022-X



V860100
Snap Hook



V860110
Form Hook



Soft Loop

PROD. NO.	MOD. NO.	Length in ft (m) (X)	Product Name	Hook Type		
				Body	Anchor	Anchor
V810110X	SA-1000-X	4, 6 (1.2, 1.8 m)	Shock Absorbing Lanyard, POY, Single Leg	Snap	Snap	
V8101116	SA-1040-6	6 (1.8 m)	Shock Absorbing Lanyard, POY, Single Leg	Loop	Snap	
V810112X	SA-1002-X	4, 6 (1.2, 1.8 m)	Shock Absorbing Lanyard, POY, Single Leg	Snap	Form	
V810120X	SA-20000-X	4, 6 (1.2, 1.8 m)	Shock Absorbing Lanyard, POY, Twin Leg 100% Tie Off	Snap	Snap	Snap
V810122X	SA-20022-X	4, 6 (1.2, 1.8 m)	Shock Absorbing Lanyard, POY, Twin Leg 100% Tie Off	Snap	Form	Form



SHOCK ABSORBING LANYARDS

Shock Pack (SP)



PeakWorks Shock Pack (SP) shock absorbing lanyards are certified to CSA Z259.11-05 standards.

- Made with a superior grade, heavy-duty 1-3/4" (45 mm) or 1" (25 mm) polyester webbing for maximum strength or 1/4" (6 mm) galvanized plastic coated cable, with tear webbing shock absorber
- Resists abrasions and harmful UV rays
- Several models feature extra-large 2-1/2" (64 mm), CSA-approved form hooks
- A tear-away absorber limits the arrest force to a maximum of 900 lbs (4 kN) for the E4 category or 1,300 lb (6 kN) for the E6 category
- Several styles are available for use in most field applications
- PeakWorks SP lanyards are available in two categories: E4 (worker weight of 100 to 254 lb [45 to 115 kg]) and E6 (worker weight of 200 to 386 lb [90 to 175 kg])



V8104306
SA-7400-6

V8104106A
SA-3400-6A

V810412X
SA-3402-X

V810415X
SA-3405-X

V810822X
SA-45522-X

V860100
Snap Hook

V860110
Form Hook

V8103172
SA-3207-2

PROD. NO.	MOD. NO.	Length in ft (m) (X) *A = Adjustable	Product Name	Webbing/ Cable	Hook Type		
					Body	Anchor	Anchor

E4 Shock Pack (SP) Lanyards - worker weight (including tools): 100-254 lb (45-115 kg)

V8103162	SA-3206-2	2 (0.6 m)	E4 Shock Absorbing Lanyard - SP - Single Leg - Snap & ADP Rope Grab - 2' (0.6 m)	1-3/4" (44 mm)	Snap	ADP Rope Grab	
V8103172	SA-3207-2	18 in (46 mm)	E4 Shock Absorbing Lanyard - SP - Single Leg - Snap & D-Ring - 18" (46 mm)	1-3/4" (44 mm)	Snap	D-Ring	
V810410X	SA-3400-X	4, 6, 6A* (1.2, 1.8 m),	E4 Shock Absorbing Lanyard - SP - Single Leg - Snap Hooks	1" (25 mm)	Snap	Snap	
V8104126A	SA-3402-6A	4, 6, 6A* (1.2, 1.8 m),	E4 Shock Absorbing Lanyard - SP - Single Leg - Snap & Form Hooks	1" (25 mm)	Snap	Form	
V810415X	SA-3405-X	4, 6 (1.2, 1.8 m)	E4 Shock Absorbing Lanyard - SP - Single Leg - 2 Snap Hooks & Tie Back	1" (25 mm)	Snap	Snap/Tie Back	
V810420X	SA-44000-X	4, 6 (1.2, 1.8 m)	E4 Shock Absorbing Lanyard - SP - Twin Leg 100% Tie Off - Snap Hooks	1" (25 mm)	Snap	Snap	Snap
V810422X	SA-44022-X	4, 6 (1.2, 1.8 m)	E4 Shock Absorbing Lanyard - SP - Twin Leg 100% Tie Off - Snap & Form Hooks	1" (25 mm)	Snap	Form	Form
V810425X	SA-44055-X	6 (1.8 m)	E4 Shock Absorbing Lanyard - SP - Twin Leg 100% Tie Off - Snap Hooks & Tie Backs - 6' (1.8 m)	1" (25 mm)	Snap	Snap/Tie Back	Snap/Tie Back
V810810X	SA-4500-X	4, 6 (1.2, 1.8 m)	E4 Shock Absorbing Lanyard - SP - Single Leg - Snap Hooks	1/4" (6 mm) Galv. Cable	Snap	Snap	
V810812X	SA-4502-X	4, 6 (1.2, 1.8 m)	E4 Shock Absorbing Lanyard - SP - Single Leg - Snap & Form Hooks	1/4" (6 mm) Galv. Cable	Snap	Form	
V810822X	SA-45522-X	4, 6 (1.2, 1.8 m)	E4 Shock Absorbing Lanyard - SP - Twin Leg 100% Tie Off - Snap & Form Hooks	1/4" (6 mm) Galv. Cable	Snap	Form	Form

E6 Shock Pack (SP) Lanyards - worker weight (including tools): 200-386 lb (90-175 kg)

V8104306	SA-7400-6	4, 6 (1.2, 1.8 m)	E6 Shock Absorbing Lanyard - SP - Single Leg - Snap Hooks	1" (25 mm)	Snap	Snap	
V8104326	SA-7402-6	4, 6 (1.2, 1.8 m)	E6 Shock Absorbing Lanyard - SP - Single Leg - Snap & Form Hooks	1" (25 mm)	Snap	Form	
V8104406	SA-84000-6	4, 6 (1.2, 1.8 m)	E6 Shock Absorbing Lanyard - SP - Twin Leg 100% Tie Off - Snap Hooks	1" (25 mm)	Snap	Snap	Snap
V8104426	SA-84022-6	4, 6 (1.2, 1.8 m)	E6 Shock Absorbing Lanyard - SP - Twin Leg 100% Tie Off - Snap & Form Hooks	1" (25 mm)	Snap	Form	Form

Preventing a fall is a better way of protecting workers than arresting a fall. For these applications, PeakWorks has a wide selection of fall restraint lanyards. Fall restraint lanyards should never be used if there is any risk of falling.

- Fall restraint lanyards are a fixed length connection and have no shock absorbing capability
- These lanyards are designed to limit the distance a worker can move from the anchor point and towards the edge of the structure and should never be used when there is a risk of falling
- PeakWorks restraint lanyards are made using two types of material – a rugged heavy-duty polyester webbing or a premium polyester rope – and with a variety of hook configurations
- PeakWorks restraint lanyards are available in 4' (1.2 m) and 6' (1.8 m) lengths



V81540X
LAN-3400-X



V81542X
LAN-3402-X



V815100X
LAN-1222-X



V815120X
LAN-1242-X



V860100
Snap Hook



V860110
Form Hook

PROD. NO.	MOD. NO.	Length in ft (m) (X)	Product Name	Hook Type	
				Body	Anchor
V81540X	LAN-3400-X	4, 6 (1.2, 1.8 m)	Restraint Lanyard with 1" (25 mm) Webbing	Snap	Snap
V81542X	LAN-3402-X	4, 6 (1.2, 1.8 m)	Restraint Lanyard with 1" (25 mm) Webbing	Snap	Form
V815100X	LAN-1222-X	4, 6 (1.2, 1.8 m)	Restraint Lanyard with 5/8" (16 mm) Rope	Snap	Snap
V815120X	LAN-1242-X	4, 6 (1.2, 1.8 m)	Restraint Lanyard with 5/8" (16 mm) Rope	Snap	Form



RETRACTABLE HORIZONTAL LIFELINES

T-Line

- The most versatile fall protection system available, the T-Line Safety System is a totally new approach to fall protection that can be used in most applications, including many that either aren't supported by existing systems or require expensive specially engineered systems
- Facilitates both horizontal and vertical freedom for the user. The system is self-retracting and self-tensioning
- Two models, one that will span up to 40' (12 m) and the XL version that will span up to 80' (24 m) in a single span
- Functions as both a self-retracting lifeline and a horizontal lifeline
- Works in both vertical and horizontal applications
- Easy to install
- Prevents the pendulum effect in the event of a fall
- Shorter fall arrest distances over large spans than most horizontal lifelines
- Each end can be mounted at different heights
- Integrated rescue winch
- Generates much lower forces on the anchors
- Can be easily serviced

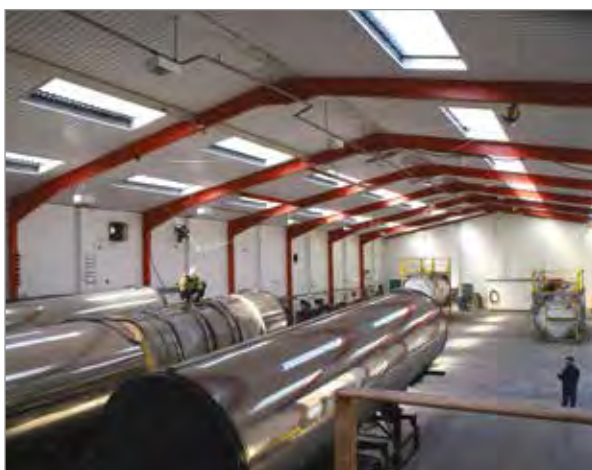

PROD. NO.	MOD. NO.	Product Name	Length	Weight
V865240	T-LINE-40	Hybrid Vertical Horizontal Retractable Lifeline	40' (12 m)	50 lb (23 kg)
V865280	T-LINE-80	Hybrid Vertical Horizontal Retractable Lifeline	80' (24 m)	60 lb (27 kg)

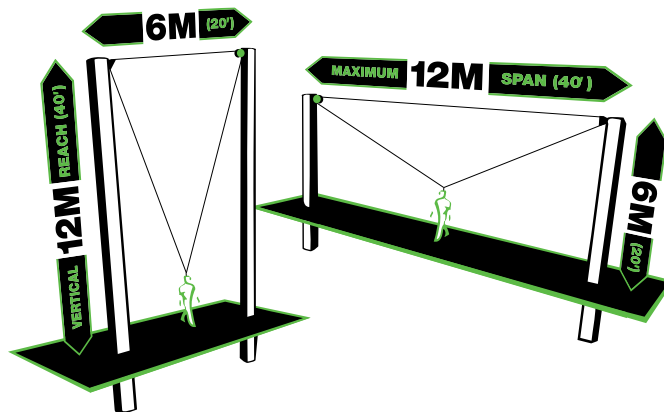

(Illustration for 40 ft (12 m) system)

V865240
T-LINE-40



PEAKWORKS®

**SELF-RETRACTING
LIFELINES**

**REACH YOUR
PEAK SAFETY
PERFORMANCE**

877



SELF-RETRACTING LIFELINES (SRL'S)

About Self-Retracting Lifelines

- Self-Retracting Lifelines (SRL's) are connectors that extend and retract as the worker moves around.
- SRL's use a locking mechanism similar to that of a seatbelt.
- Under normal use, the worker can move about while the SRL keeps them connected between the harness and anchor point.
- If the worker slips or falls, the mechanism locks the SRL, preventing further extension of the lifeline.
- SRL's offer the worker the greatest amount of mobility and work distance from the anchor point.
- SRL's offer shorter stopping distances than traditional lanyards.



SELF-RETRACTING LIFELINES (SRL'S)

- PeakWorks has introduced a new series of premium Self-Retracting Lifelines
- Manufactured in Germany to exacting specifications using lightweight aluminum or plastic housings for maximum operator comfort
- Certified to CSA Z259.2.1
- Aluminum units are available using heavy-duty polyester webbing or galvanized steel cable
- Plastic housing units available with heavy-duty webbing only
- PeakWorks webbing SRL's are manufactured using special 0.1" (2.5 mm) thick, 1" (25 mm) wide Dyneema® Core materials, giving them one of the highest performances of this type of fibre in the world
- The anchor point incorporates a heavy-duty, durable and convenient swivel eye
- SRL's with webbing feature a sewn-in indicator on the lifeline itself for maximum safety
- Rescue units come with release pins and a two-way winding handle to engage the rescue/recovery mode
- Available in lengths from 6 to 108 ft (1.8 to 33 m)
- Available in single and double leg versions
- 300 lb (136 kg) capacity for 1 worker (combined weight of person, tools, clothing, etc.)

LEADING EDGE SELF-RETRACTING LIFELINES

- Leading Edge (LE) self-retracting lifelines are designed to protect the worker when operating near an edge and where a fall hazard exists that could cause the lifeline to come into contact with the edge
- Leading Edge SRL's provide additional protection against sharp or abrasive surfaces found on many construction sites
- A Leading Edge SRL can be mounted below a worker's fall arrest D-Ring (please refer to instruction manual for details)
- **Certified to CSA Z259.2.2-98** (for non-Leading Edge applications) and **ANSI Z359.14** (for Leading Edge applications)
- **No external shock absorber** – We are the only manufacturer that offers LE certified units which can be used without external shock absorbers
- Lightweight units can be mounted on a worker's harness for better mobility and range of motion
- All LE products are clearly marked to ensure the correct SRL is used for Leading Edge applications

SELF-RETRACTING LIFELINES (SRL'S)



V84511008
SRL-10301-8



V845523006
SRL-50302-6



V8454230XX
SRL-40302-XX



V845525007
SRL-50502-7



V845526007
SRL-50602-7



V8455330XX
SRL-53302-XX



V8455340XX
SRL-53303-XX



PROD. NO.	MOD. NO.	Product Name	ANSI Z359.14-2012 LE Certified	Housing	Webbing/Cable	Length in ft (m)	CSA Z259.2.2-98 Type
V84511008	SRL-10301-8	SRL with Webbing, Snap Hook	No	Steel Frame	1-3/4" (45 mm) Webbing	8 (2.4 m)	1
V845523006LE	SRL-50302-6LE	SRL with Webbing, Snap Hook	Yes	Aluminum	1" (25 mm) Webbing	6 (1.8 m)	2
V845423012	SRL-40302-12	SRL with Webbing, Snap Hook	No	Plastic	1" (25 mm) Webbing	12 (3.5 m)	2
V845423018	SRL-40302-18	SRL with Webbing, Snap Hook	No	Plastic	1" (25 mm) Webbing	18 (5.5 m)	2
V845525007LE	SRL-50502-7LE	SRL with Webbing, Twin Leg, Snap Hook	Yes	Aluminum	1" (25 mm) Webbing	7 (2 m)	2
V845526007LE	SRL-50602-7LE	SRL with Webbing, Twin Leg, Form Hook	Yes	Aluminum	1" (25 mm) Webbing	7 (2 m)	2
V845533020LE	SRL-53302-20LE	SRL with Galv. Steel Cable, Snap Hook	Yes	Aluminum	3/16" (5 mm) Cable	20 (6 m)	2
V845533040LE	SRL-53302-40LE	SRL with Galv. Steel Cable, Snap Hook	Yes	Aluminum	3/16" (5 mm) Cable	40 (12 m)	2
V845533060LE	SRL-53302-60LE	SRL with Galv. Steel Cable, Snap Hook	Yes	Aluminum	3/16" (5 mm) Cable	60 (18 m)	2
V845534060	SRL-53303-60	SRL with Galv. Steel Cable, Rescue/Recovery, Snap Hook	No	Aluminum	3/16" (5 mm) Cable	60 (18 m)	3
V845534108	SRL-53303-108	SRL with Galv. Steel Cable, Rescue/Recovery, Snap Hook	No	Aluminum	3/16" (5 mm) Cable	108 (33 m)	3



ANCHORAGE CONNECTORS

Anchors and Roof Brackets

- A complete fall arrest system requires three primary components: approved full body harness, connector and anchorage connector
- Anchors can be connected to a variety of materials such as steel, wood and concrete
- PeakWorks offers a wide range of anchor systems including: single-use/reusable roof anchors, sliding beam anchors, concrete hole anchors and permanent anchors
- The anchor should be located directly above the worker to prevent swinging
- The height of an anchor is a key variable when determining fall clearance
- As with all fall protection products, anchors must be inspected by a competent person at a minimum annually
- All PeakWorks anchors are built with a minimum tensile strength of 5,000 lb (22 kN)
- All PeakWorks anchors meet or exceed CSA Z259.15 and ANSI Z359.18 standards and OSHA requirements
- 310 lb (141 kg) capacity for 1 worker (combined weight of person, tools, clothing, etc.)



V822111X
CP-10011-X

V8229001
RB-9701

V8229100
RB-9800

V8221114
CP-10010-1

V8221115
CP-10010-2

V8221121
CP-12010-2



V8229104
RB-9900



V8222120
CP-12010-1



V8222130
CP-11010-1

PROD. NO.	MOD. NO.	Product Name	Application
V8221111	CP-10011-1	Permanent Anchorage with 1/2" (13 mm) Hole	Permanent
V8221112	CP-10011-2	Permanent Anchorage with 5/8" (16 mm) Hole	Permanent
V8221113	CP-10011-3	Permanent Anchorage with 3/4" (19 mm) Hole	Permanent
V8229001	RB-9701	Single-Use Roof Bracket	Temporary
V8229100	RB-9800	Reusable Roof Anchor Bracket	Temporary
V8221114	CP-10010-1	5K Concrete Swivel Anchor with 5/8" (16 mm) Sleeve Anchor	Permanent
V8221115	CP-10010-2	5K Steel Swivel Anchor with 1/2" x 4" (13 mm x 102 mm) G8 Steel Bolt Lock Washer and Lock Nut	Permanent
V8221121	CP-12010-2	3/4" (19 mm) Toggle-Lok Anchor	Temporary
V8229104	RB-9900	Stainless Steel Reusable Roof Anchor Bracket	Temporary
V8222120	CP-12010-1	3/4" (19 mm) Concrete Hole Anchor	Temporary
V8222130	CP-11010-1	Adjustable Sliding Beam Anchor - Fits Beam Flange Width of 3.5" to 13.25" (88.9 mm to 336.6 mm)	Temporary

ANCHORAGE CONNECTORS

Anchor Slings



- Anchor slings provide peace of mind when a temporary anchor is required
- PeakWorks offers anchor slings using two basic material styles: abrasion-resistant webbing or galvanized cable
- All PeakWorks anchor slings are built to a minimum tensile strength of 5,000 lb (22 kN)
- All PeakWorks anchor slings meet or exceed CSA and ANSI standards



V820310X
RAS3-X



V820350X
CAS-X



V820800X
AS-21000-X



V820840X
AS-21210-X



V820860X
AS-21110-X

PROD. NO.	MOD. NO.	Length in ft (m) (X)	Product Name	End Configuration	
				End 1	End 2
V820310X	RAS3-X	3, 4, 6 (0.9, 1.2, 1.8 m)	Residential Anchor Sling	Reinforced Loop	Loop
V820350X	CAS-X	3, 4, 6 (0.9, 1.2, 1.8 m)	Commercial Anchor Sling	Loop	D-Ring
V820800X	AS-21000-X	4, 6 (1.2, 1.8 m)	Cable Anchor Sling, 1/4" (6 mm) PVC Coated Galv. Cable	Eye	Eye
V820840X	AS-21210-X	4, 6 (1.2, 1.8 m)	Cable Anchor Sling, 1/4" (6 mm) PVC Coated Galv. Cable	Snap Hook	O-Ring
V820860X	AS-21110-X	4, 6 (1.2, 1.8 m)	Cable Anchor Sling, 1/4" (6 mm) PVC Coated Galv. Cable	O-Ring	O-Ring





ROPE GRABS AND LIFELINES

Rope Grabs

- All PeakWorks rope grabs are certified to CSA Z259.2.5-2012 and meet ANSI Z359 standards
- Rope grabs are designed to travel hands-free on 5/8" (16 mm) rope
- These automatic rope grabs follow the user during their ascent or descent
- In the event of a fall, the rope grab will "bite" onto the rope and arrest the user's fall
- PeakWorks rope grabs are also equipped with a panic lock feature which "bites" onto the rope even if the user mistakenly pushes the cam up, ensuring that the rope grab will lock and arrest the fall in any situation
- Rope grabs offer the most cost-effective fall protection solution when working at height
- Cable grabs are designed for use on 3/8" (9.5 mm) cable
- 300 lb (136 kg) capacity (combined weight of person, tools, clothing, etc.)



V83010
RG-11010



V83011
RG-11000



V83012
RG-21000 *



V83021
CG-9001 *

PROD. NO.	MOD. NO.	Product Name	Rope/Cable	
			Size	Type
V83010	RG-11010	ADP Rope Grab with Panic Grab, Small Eye	5/8" (16 mm)	3 Strand
V83011	RG-11000	ADP Rope Grab with Panic Grab, Large Eye	5/8" (16 mm)	3 Strand
*V83012	RG-21000	ADP Rope Grab (SS) with Panic Grab, Large Eye	5/8" (16 mm)	3 Strand
*V83021	CG-9001	Cable Grab for 3/8" (10 mm) Cable	3/8" (10 mm)	Galvanized Cable

* Meet or exceed CSA Z259.2.5-2012



ROPE GRABS AND LIFELINES

Lifelines

- All PeakWorks lifelines are certified to CSA Z259.2.5-2012 and meet ANSI Z359 standards
- Lifelines are specially designed from rope made using high-strength polysteel
- Polysteel is an extruded co-polymer fibre that yields an extremely high-strength, lightweight rope with excellent resistance to acids and alkalis
- PeakWorks vertical lifelines are all 5/8" (16 mm) in diameter
- Minimum breaking strength 6,000 lb (27 kN)
- We offer a wide range of lengths with a variety of snap hook/carabiner options
- All PeakWorks lifelines have a back splice at the trailing end to prevent the rope grab from coming off the end of the lifeline



V84013XXX
VL-1115-X



V84014XXX
VL-1125-X



PROD. NO.	MOD. NO.	Length in ft (m) (X)	Product Name	End Configuration	
				Anchor End	Trailing End
V84013XXX	VL-1115-X	25, 50, 100 (7.6, 15.2, 30.5 m)	Vertical Lifeline, 5/8" (16 mm) Rope	Carabiner	Back Splice
V84014XXX	VL-1125-X	25, 50, 100 (7.6, 15.2, 30.5 m)	Vertical Lifeline, 5/8" (16 mm) Rope	Snap Hook	Back Splice

Note: other lengths available as a special order.

PeakWorks has kits configured by application and working environment, making it easy to choose the right product for the job.

- *All PeakWorks kit components are certified to the applicable CSA standards.*
- *PeakWorks offers a wide range of pre-packaged fall protection kits that include specific full body harnesses and connectors and, in the case of roofer's kits, a shock-absorbing panic rope grab and anchor.*
- *PeakWorks kits come in a waterproof pail or a breathable bag for convenient storage.*





PEAKWORKS®

KITS



885



KITS
Roofer's Kits



V8257022
RK2-25:

- **FBH-10000A** Contractor Harness
- **SA-3206-2** SP Lanyard with Integral ADP Rope Grab
- **VL-1825-25** Vertical Lifeline
- **RB-9800** Reusable Roof Bracket
- 15 l (4 gal) Waterproof Pail

V8257025
RK2-50:

- **FBH-10000A** Contractor Harness
- **SA-3206-2** SP Lanyard with Integral ADP Rope Grab
- **VL-1825-50** Vertical Lifeline
- **RB-9800** Reusable Roof Bracket
- 15 l (4 gal) Waterproof Pail



V8257032
RK3-25:

- **FBH-10002A** Compliance Harness
- **SA-3206-2** SP Lanyard with Integral ADP Rope Grab
- **VL-1125-25** Vertical Lifeline
- **RB-9701** Single-Use Roof Bracket
- 4" Spiral Ardox® Nails (Bag of 8)
- 15 l (4 gal) Waterproof Pail

V8257035
RK3-50:

- **FBH-10002A** Compliance Harness
- **SA-3206-2** SP Lanyard with Integral ADP Rope Grab
- **VL-1125-50** Vertical Lifeline
- **RB-9701** Single Use Roof Bracket
- 4" Spiral Ardox® Nails (Bag of 8)
- 15 l (4 gal) Waterproof Pail



V8257042
RK4-25:

- **FBH-10002A** Compliance Harness
- **SA-3206-2** SP Lanyard with Integral ADP Rope Grab
- **VL-1825-25** Vertical Lifeline
- **RB-9800** Reusable Roof Bracket
- 15 l (4 gal) Waterproof Pail

V8257045
RK4-50:

- **FBH-10002A** Compliance Harness
- **SA-3206-2** SP Lanyard with Integral ADP Rope Grab
- **VL-1825-50** Vertical Lifeline
- **RB-9800** Reusable Roof Bracket
- 15 l (4 gal) Waterproof Pail

BEST-SELLER



V8257055
RK5-50:

- **FBH-10002A** Compliance Harness
- **SA-3200-2.5** SP Lanyard with regular snap hooks
- **RG-11010** ADP Rope Grab
- **VL-1825-50** Vertical Lifeline
- **RB-9800** Reusable Roof Bracket
- 15 l (4 gal) Waterproof Pail

PROD. NO.	MOD. NO.	Length in ft (m) (X)	Product Name
V825702X	RK2-X	25, 50 (7.6, 15.2 m)	Contractor Roofer's Kit with Reusable Bracket and 2' (0.6 m) SP Lanyard with Integral ADP Rope Grab
V825703X	RK3-X	25, 50 (7.6, 15.2 m)	Compliance Roofer's Kit with Single-Use Bracket and 2' (0.6 m) SP Lanyard with Integral ADP Rope Grab
V825704X	RK4-X	25, 50 (7.6, 15.2 m)	Compliance Roofer's Kit with Reusable Bracket and 2' (0.6 m) SP Lanyard with Integral ADP Rope Grab
V8257055	RK5-50	50 (15.2 m)	Compliance Roofer's Kit with Reusable Bracket and 2.5' (0.7 m) SP Lanyard and Non-Integral ADP Rope Grab



V8253014
PIP1-4:

- **FBH-10002A** Compliance Harness
- **SA-3400-4** Shock Absorbing Lanyard
- 8 l (2.1 gal) Waterproof Pail

V8253016
PIP1-6:

- **FBH-10002A** Compliance Harness
- **SA-3400-6** Shock Absorbing Lanyard
- 8 l (2.1 gal) Waterproof Pail

BEST-SELLER



- V8253024
PIP2-4:
- **FBH-10002A** Compliance Harness
 - **SA-3402-4** Shock Absorbing Lanyard
 - 8 l (2.1 gal) Waterproof Pail

- V8253026
PIP2-6:
- **FBH-10002A** Compliance Harness
 - **SA-3402-6** Shock Absorbing Lanyard
 - 8 l (2.1 gal) Waterproof Pail



- V8253074
PIP7-4:
- **FBH-10000A** Contractor Harness
 - **SA-1000-4** Shock Absorbing Lanyard
 - 8 l (2.1 gal) Waterproof Pail

- V8253076
PIP7-6:
- **FBH-10000A** Contractor Harness
 - **SA-1000-6** Shock Absorbing Lanyard
 - 8 l (2.1 gal) Waterproof Pail



- V8253084
PIP8-4:
- **FBH-10000A** Contractor Harness
 - **SA-1002-4** Shock Absorbing Lanyard
 - 8 l (2.1 gal) Waterproof Pail

- V8253086
PIP8-6:
- **FBH-10000A** Contractor Harness
 - **SA-1002-6** Shock Absorbing Lanyard
 - 8 l (2.1 gal) Waterproof Pail

PROD. NO.	MOD. NO.	Length in ft (m) (X)	Product Name
V825301X	PIP1-X	4, 6 (1.2, 1.8 m)	Compliance PIP Kit with SP Lanyard, 2 Snap Hooks
V825302X	PIP2-X	4, 6 (1.2, 1.8 m)	Compliance PIP Kit with SP Lanyard, Snap & Form Hooks
V825307X	PIP7-X	4, 6 (1.2, 1.8 m)	Contractor PIP Kit with POY Lanyard, 2 Snap Hooks
V825308X	PIP8-X	4, 6 (1.2, 1.8 m)	Contractor PIP Kit with POY Lanyard, Snap & Form Hooks



KITS
Fall Protection Kits



V8252096
FK-001:

- **FBH-10002A** Compliance Harness
- **SA-1040-6** Shock Absorbing Lanyard
- **BAG-001** Large Mesh Bag



V8252116
FK-002:

- **FBH-10000A** Contractor Harness
- **SA-1000-6** Shock Absorbing Lanyard
- **BAG-001** Large Mesh Bag



V8252036
FK-003:

- **FBH-10002A** Compliance Harness
- **SA-3400-6** Shock Absorbing Lanyard
- **BAG-001** Large Mesh Bag



V8252034
FK-004:

- **FBH-10002A** Compliance Harness
- **SA-3400-4** Shock Absorbing Lanyard
- **BAG-001** Large Mesh Bag



V8252196
FBH-10000A1040-6:

- **FBH-10000A** Contractor Harness
- **SA-1040-6** Shock Absorbing Lanyard

PROD. NO.	MOD. NO.	Product Name
V8252096	FK-001	Compliance Fall Protection Kit with 6' (1.8 m) POY Lanyard
V8252116	FK-002	Contractor Fall Protection Kit with 6' (1.8 m) POY Lanyard
V8252036	FK-003	Compliance Fall Protection Kit with 6' (1.8 m) SP Lanyard
V8252034	FK-004	Compliance Fall Protection Kit with 4' (1.2 m) SP Lanyard
V8252196	FBH-10000A1040-6	Contractor Fall Protection Kit with 6' (1.8 m) POY Lanyard

- Canadian law states that every company must be prepared for a rescue and therefore every fall protection application and work environment must have a pre-planned rescue system established.
- As time is critical when responding to a worker in need, it is incumbent upon all job sites to have the right equipment and proper training available in case of an emergency.
- PeakWorks offers a wide range of equipment and training to help you develop the rescue system required for your specific application.
- Contact your representative for details.

RES-Q-Pole

- The PeakWorks Res-Q-Pole with Res-Q-Head is an innovative and effective solution designed to remotely connect a carabiner to a fallen worker or anchor
- The pole is a strong yet lightweight fibreglass-constructed telescoping pole that reaches from 6 to 12' (1.8 to 3.7 m)
- A lightweight bracket holds the carabiner open until the operator hooks onto the victim's D-ring or anchor and pulls back. At that point the carabiner is released from the head and snaps shut
- Designed for use with the CP-03015-1 carabiner (sold separately)

RES-Q-Kit

- The Res-Q-Kit is a unique 4:1 100' (30.4 m) raise and lower kit; it allows a person to be lowered using friction or raised by using a mechanical one-directional pulley
- The Res-Q-Kit is our most effective retrieval kit



V855121
RES-Q-POLE w RES-Q-HEAD



V85523100
RES-Q-KIT 100'



V860120
CP-03015-1
(Carabiner sold separately)

PROD. NO.	MOD. NO.	Product Name
V855121	RES-Q-POLE w RES-Q-HEAD	Rescue Pole, Telescoping 6 to 12' (1.8 m to 3.7 m), with Rescue Head Carabiner Attachment
V85523100	RES-Q-KIT 100'	Res-Q-Kit, 100' (30.4 m)

About Confined Space

- OHS Regulations define a confined space as an area, other than an underground working, that:
 - is enclosed or partially enclosed;
 - is not designed or intended for continuous human occupancy;
 - has limited or restricted means for entry or exit that may complicate the provision of first aid, evacuation, rescue or other emergency response or service;
 - is large enough and so configured that a worker could enter to perform assigned work.
- Confined space has limited openings for entry and exit. Examples would be spaces such as: silos, vats, ship holds, sewers, tunnels, large pipelines and other such spaces that humans could enter to perform work.

FALL PROTECTION FOR CONFINED SPACE



- The PeakWorks engineering team has developed a unique tripod with distinct advantages over the competition
- The PeakWorks TR-100 Tripod offers a built-in pulley system that is located above the head assembly
- The placement of this pulley situates the wire rope cable directly over the centre point of the tripod for superior perfect operator balance
- Locating the pulley system above the head assembly also allows the operator increased head room over traditional "below-the-head" pulley systems
- The PeakWorks TR-100 features adjustable aluminum legs complete with swivel steel feet and non-slip rubber bases
- The TR-100 can be used with a 65' (20 m) Man Rated Winch (MW-65G) or, by attaching the tripod mounting bracket, with a PeakWorks SRL-53303 60' (18 m) or 108' (33 m) recovery style SRL
- 7' (2 m) tripod features adjustable locking legs, two additional anchorage points, non-slip safety feet and safety chain
- Meets or exceeds CSA Z259.15 and ANSI Z359.18 and OSHA requirements
- MW-65G man winch features 65' (20 m) galvanized cable with swivel hook, 300 lb (135 kg) capacity
- 310 lb (141 kg) capacity (combined weight of person, tools, clothing, etc.)



PROD. NO.	MOD. NO.	Product Name
V85011	TR-100	7' (2 m) Tripod with Chain and Pulley
V84537065	MW-65G	65' (20 m) Man Winch with 3/16" (5 mm) Cable and Swivel Hook
V85024	CSK1-60	Confined Space Kit: Tripod, 3-Way 60' (18 m) SRL and Bag
V85025	CSK2-65	Confined Space Kit: Tripod, 65' (20 m) Man Winch and Bag
V85026	CSK3-60	Confined Space Kit: Tripod, 3-Way 60' (18 m) SRL, 65' (20 m) Man Winch and Bag
V860005	BAG-005	Tripod Carrying Bag
V855130	CP-15300-3	Confined Space Yoke
V860151	CP-41210-1	Aluminum Pulley – Single Oscillating Side Plates
V860152	CP-41210-2	Aluminum Pulley – Double Oscillating Side Plates
V8460	SRL-53303-BRKT	Tripod Mounting Bracket for SRL-53303



V860001
BAG-001



V860004
BAG-004



V860901
MERCHANDISING TORSO



V860005
BAG-005



V860402
RFID-1



V860130
CP-04011-1



V860120
CP-03015-1



V860121
CP-03015-2



V860301
FBH-PAD



V860140
RA-100



V860304
CP-22300-1



V860303
CP-23300-1



V860302
CP-14010



V860151
CP-41210-11



V860152
CP-41210-2

PROD. NO.	MOD. NO.	Product Name	PROD. NO.	MOD. NO.	Product Name
V860001	BAG-001	Large Mesh Harness Bag 15" x 12" (38 cm x 31 cm)	V860140	RA-100	Rebar Assembly
V860004	BAG-004	PeakWorks Carrying Bag 10" x 12" x 12" (25 cm x 31 cm x 31 cm)	V860304	CP-22300-1	Tool Lanyard
V860005	BAG-005	Tripod Carrying Bag for TR-100 10" x 58" x 10" (147 cm x 25 cm x 25 cm)	V860303	CP-23300-1	Trauma Strap
V860402	RFID-1	RFID Pouch with Grommet	V860302	CP-14010	D-Ring Extender 18" (46 cm)
V860130	CP-04011-1	Carabiner 2" (50 mm) CSA for Scaffolding	V860151	CP-41210-1	Aluminum Pulley - Single Osc. Side Plates
V860901	MERCH. TORSO	Merchandising Torso for Harness	V860152	CP-41210-2	Aluminum Pulley -. Double Osc. Side Plates
V860120	CP-03015-1	Carabiner 1" (25 mm) CSA CE			
V860121	CP-03015-2	Carabiner 3/4" (19 mm) CSA for CG-9001 & SRL-10301-8)			
V860301	FBH-PAD	Removable Back Pad for PW harnesses			



PEAKWORKS SERVICES

Audit

Every company is required to have a fall protection plan. A thorough fall protection plan must begin with an audit of the worksite or facility. The PeakWorks audit process identifies all of the fall hazards at the workplace and reviews the current fall protection practices in place. A PeakWorks audit will recommend systems, products, and the procedures to eliminate or mitigate the risk of working at heights.

Inspection and Cleaning

PeakWorks' RFID Inspection system is a fast, easy and reliable way to inspect your PPE. The RFID chip is the key to the system, integrating each piece of equipment with the product type, date of manufacture, serial number and relevant product standards. PeakWorks' inspection customers receive a timely email informing them when equipment is due for inspection.



Search "PeakWorks" to download our free Fall Clearance Calculator App



STANDARDS AND REGULATIONS

CSA Standards



CSA Z259.1-05 (R2010).....	Safety Belts and Saddles for work positioning and travel restraint
CSA Z259.2.2-98 (R2009).....	Self-Retracting Devices for Personal Fall-Arrest Systems
CSA Z259.2.3-12	Descent Control Devices
CSA Z259.2.4-15.....	Fall Arrester and Fixed Rigid Rails
CSA Z259.2.5-12.....	Fall Arresters and Vertical Lifelines
CSA Z259.10-12	Full Body Harness
CSA Z259.11-05 (R2010)	Energy Absorbers and Lanyards
CSA Z259.12-11	Connecting Components for Personal Fall Arrest Systems
CSA Z259.13-04 (R2009)	Flexible Horizontal Lifelines
CSA Z259.14-12	Fall Restrict Equipment for Wood Pole Climbing
CSA Z259.15-12	Anchorage Connectors
CSA Z259.16-04 (R2009)	Design of Active Fall Protection Systems

Canadian Standards Association

178 Rexdale Boulevard
Toronto, Ontario M9W 1R3
www.csa.ca

OSHA REGULATIONS GOVERNING CONSTRUCTION (29 CFR PART 1926)

Subpart E covers various requirements for personal protective equipment.

Safety Belts, Lifelines and Lanyards	1926.104
Safety Nets.....	1926.105

Subpart L covers Scaffolds.....1926.450-454

Subpart M covers fall protection fully, including when and where fall protection systems are required and for what construction work activities. It also defines system component requirements.

Scope, Application and Definitions.....	1926.500
Duty to Have Fall Protection	1926.501
Fall Protection Systems Criteria and Practices	1926.502
Training Requirements.....	1926.503

Subpart X covers Ladders.....1926.1053

OSHA REGULATIONS GOVERNING GENERAL INDUSTRY (29 CFR PART 1910)

Subpart D mentions a few specific Fall Protection requirements relative to walking/working surfaces.

Fixed Ladders, Ladder Safety Devices.....	1910.27(d)(5)
Safety Requirements for Scaffolding, Boatswain's Chairs.....	1910.28(j)(4)

Subpart F covers fall protection as it pertains to powered platforms, man lifts, and vehicle mounted work platforms.

Maintenance	1910.66
Personal Fall Arrest Systems.....	1910.66

Subpart J covers general environmental controls in which confined spaces are addressed.

Confined Spaces.....	1910.146
----------------------	----------

ANSI STANDARDS GOVERNING CONSTRUCTION AND DEMOLITION OPERATIONS

Safety Requirements for Personal Fall Arrest Systems, Subsystems and Components.....	Z359.1-2007
--------------------------------------------------------------------------------------	-------------

AMERICAN NATIONAL STANDARDS INSTITUTE, INC. (ANSI)

11 West 42nd Street
New York, NY 10036
www.ansi.org



PROclub

BECOME A MEMBER

PROclub is an exclusive club built for professional workers like you. Members are first to hear about tools, equipment, and safety gear for the entire range of SureWerx brands. Activate your membership by visiting yourproclub.com and join Canada's premiere tool and safety community!

WHY JOIN?

- Take advantage of exclusive promotions
- Receive flyer deals
- New product sneak peeks
- Play interactive games
- Receive monthly newsletters
- Watch product videos and tutorials
- Enter contests to win prizes

JOIN PROCLUB TODAY AT YOURPROCLUB.COM



PPE

SAFETY AND PRODUCTIVITY

DESIGN

From adjustable temples to balanced and ergonomic helmets, we design our products with your safety and comfort in mind.

QUALITY

With features like anti-fog, scratch resistance and auto-darkening filters, only the best materials are used in our products.

STANDARDS

Our products meet or exceed industry standards to ensure you get the job done safely and comfortably.



DID YOU KNOW?

In 1923 Sellstrom began as a family owned manufacturer of Personal Protective Equipment

GET READY CANADA

sellstrom®

IS MOVING IN!

That's right! Sellstrom, one of America's oldest and most respected brands of PPE safety products is coming to Canada in a big way. On November 2nd, 2015 SureWerx acquired the Sellstrom Manufacturing Co., a 92-year-old manufacturer and wholesale distributor of Personal Protective Equipment (PPE) located in Schaumburg, Illinois. Very shortly, this exciting safety portfolio will be available in all six of our warehouses alongside our already unparalleled line-up of professional tools and safety products.



Monitor® 2000 Germicide Cabinet

OUR "FAMILY OF BRANDS" WELCOMES ITS LATEST ADDITION:

sellstrom®

Product that works.

We have been laser focused in our pursuit of building a unique company that not only offers the most extensive range of tool and safety products, but has achieved this by strategically targeting and acquiring some of the best brands in the business. Each of these brands carried a unique level of market and product expertise. At SureWerx™, we have fused the strengths of each of these companies to form an unprecedented wholesale supplier of products and services. The addition of the Sellstrom brand, product range and accompanying industry experts continues to build on that legacy.

SureWerx™

One Source for Peace of Mind!

By adding Sellstrom to our ever growing family of brands and products, our mission to offer Canada the most comprehensive and innovative head-to-toe portfolio of premium tool and safety products just took a giant leap forward. Where else but SureWerx™ can one source bring you the technical expertise, product innovation and range, coast-to-coast distribution network and after sales service to provide you, the Canadian worker complete peace of mind?

sellstrom® PRODUCTS

Just like Pioneer (safety apparel and footwear), and PeakWorks (fall protection), Sellstrom offers an extensive range of industry-leading PPE and welding safety products for the professional user. Over the past 92 years, Sellstrom has been a leading innovator in safety, introducing a wide range of "firsts" into the USA market and beyond. Our mission remains the same - we will continue to design, develop and introduce new and exciting products with the sole purpose of keeping you, the worker, safe so that you can go home at night the same way you showed up for work in the morning. Here are just a few examples of what's to come:

Face Shields: Sellstrom is a leader in face protection, offering several models with unique and innovative safety features designed to ensure maximum safety for users everywhere.

Goggles: Sellstrom is one of the industry leaders in safety goggles. Our dual lens Odyssey series goggles are 100% fog free, the best in the business no matter the conditions. Odyssey goggles are available in several versions for a wide variety of applications including: industrial, chemical splash, clean room and tactical, as well as the very first NFPA certified Wildland Fire google on the market.

Gravit-Eye Portable Eyewash Unit: Exclusive Gravit-Eye self-contained 16 gallon gravity eyewash unit delivers water through dual spray heads.

Monitor Germicidal Cabinet: Exclusive Sellstrom Monitor germicidal cabinet is the industry leader in quality and performance. Kills 99.2% of all germs in just 5 minutes! Now available in two sizes - the traditional model for school and laboratory institutions and the new smaller version for doctor's and dentist's offices.



Model DP4 – exclusive flip-down IR window provides uninterrupted protection for grinding, brazing and cutting operations



380 Series – made in the USA using super acetate materials, offering virtually zero distortion and superior scratch resistance over traditional polycarbonate materials



MERCHANDISERS





NEW HAND TOOLS DISPLAY MERCHANDISERS



NEW

HAMMER DISPLAY HOOK

890927



NEW

PUMP DISPLAY RACK

890679



NEW

**21 PC LUBRICATION
& FLUID TRANSFER**

890481



NEW

**27 PC LUBRICATION &
FLUID TRANSFER**

890482



**49 PC LUBRICATION
& FLUID TRANSFER**

890483



PUNCH & CHISELS

890167



ERGONOMIC SCREWDRIVERS

890485



HAND TOOLS DISPLAY MERCHANDISERS



SAE CHROME SOCKETS
1/4", 3/8" & 1/2" DR

890181



METRIC CHROME SOCKETS
1/4", 3/8" & 1/2" DR

890182



1/2" DRIVE IMPACT SOCKETS

890187



HEX AND TORX® SOCKETS

890184



3/4" DR IMPACT SOCKETS

890455



3/4" DR DEEP IMPACT SOCKETS

890456



12 PT. CHROME SOCKETS
1/4" & 3/8"

890444



HEX TOOLS

890428



3/4" DR SOCKET TOOLS

890195



SOCKET ACCESSORIES

890430



HEX KEYS

890429



HEX AND TORX® BITS

890457



COMBINATION WRENCHES

890177



COMBINATION RATCHET WRENCHES

890426



LONG PATTERN COMBINATION WRENCHES

890407



ADJUSTABLE WRENCHES

890174



CHROME NICKEL PLIERS DISPLAY

890471



CHROME VANADIUM PLIERS DISPLAY

890472



LOCKING PLIERS

890427



ELECTRICAL TOOLS

890442



AVIATION SNIPS

890446



BOLT CUTTERS

890175



ABRASIVES DISPLAY MERCHANDISERS



**POWERPLUS®
THIN CUT-OFF WHEELS**

890461 / JCOWDB-191



POWERBLEND® FLAPDISCS

890462 / JPBFD-75



CRIMPED WIRE BRUSHES

890463 / JCWBD-20



KNOTTED BRUSHES

890464 / JKWDB-30



**POWERPLUS®
DEPRESSED CENTRE WHEELS**

890499 / JPPXCWD-107



**POWER ABRASIVE™
WHEELS**

890466 / JPAWD-173



**4-1/2" - 6" ABRASIVE WHEELS
DISPLAY SHELF**

890928



**7" - 8" ABRASIVE WHEELS
DISPLAY SHELF**

891147



**12" - 14" ABRASIVE WHEELS
DISPLAY SHELF**

891148



SHAFT MOUNTED BRUSHES

890424 / JWDB-38

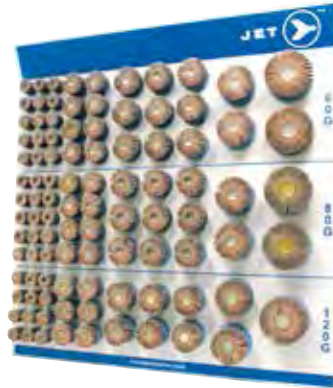

MOUNTED FLAPWHEELS

890435 / JFWM-99



ROLL-ON DISCS

890633 / JMMDM-21



CUTTING & GRINDING CENTRE

890473 / JCGCDB

NEW



HAND SCRATCH BRUSHES

890476 / JSBDB-102



ABRASIVES DISPLAY MERCHANDISERS



JET-KUT® SUPER PREMIUM CARBIDE BURS DISPLAY

890404 / JCBK24



JET-KUT® PREMIUM CARBIDE BURS DISPLAY

890450 / JCBK22



PRENTICE DRILL BITS

890402 / PBDB-7

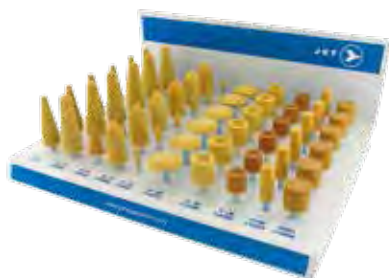

MOUNTED POINTS

890145 / MPDM-60



JET-KUT® PREMIUM TAPS & DIES

890516 - 58 PC

890517 - 41 PC

890518 - 32 PC

890519 - 9 PC

890520 - 7 PC



HOLESAWS

890183 / JHSDB-31



NEW DESIGN

CARDED ENGINEERING FILES

890417 / JFDM-69



POWER-XTRME DUO™
(Previously POWERPLUS® TZ+ Duo T-27)
Cutting and Light Grinding
Cut-Off Wheels

890467 / JCGTWDB-58

**JET-KUT® COBALT
JOBBER BITS**

890440 / JDBCM-264

**JET-KUT® GOLD
JOBBER BITS**

890168 / JDB-264

**JET-KUT®
JOBBER BITS**

890411 / JCDB-348

**JET-KUT® B & G SERIES
JOBBER BITS**

890441 / JDBBGM264



**POWER-XTREME™
(Previously POWERPLUS TZ+) Abrasive
Wheels Merchandiser Kit**

890502



**POWER-XTREME™
(Previously POWERPLUS TZ+) Abrasive
Wheels Merchandiser Kit**

890503



**POWERBLEND® FLAP DISCS
MERCHANTISER KIT**

890504



**POWERBLEND® SCD
FLAP DISCS MERCHANTISER KIT**

890505



**POWERBLEND® TRM
FLAP DISCS MERCHANTISER KIT**

890506



WIRE BRUSH BOARD

Designed for sales calls or display

890477 / JWDBB-12



AIR TOOLS DISPLAY MERCHANDISERS



AIR TOOLS

890625

Suggested assortments



UNIVERSAL AIR TOOL DISPLAY

890484



FILTER, REGULATOR & LUBRICATOR

890475



BLOW GUNS

890449



AIR FITTINGS

890460



PNEUMATIC BITS

890452



AIR HOSES

890670





MATERIAL HANDLING DISPLAY MERCHANDISERS



LEVER PULLERS

890432 / SSCP-8

- Constructed of heavy gauge steel
- Space-conscious design
- Displays two lever pullers out of the box
- Stores three of each puller
- E06961 – SLP25 1/4t Sumo® puller (qty 4)
- E06962 – SLP50 1/2t Sumo® puller (qty 4)
- 890631 – Puller display rack (in box) (qty 1)
- 890696 – Sign for SSCP-8 display (qty 1)



CABLE PULLERS

890431 / JCCPP-8

- Constructed of heavy gauge steel
- Space-conscious design
- Displays two cable pullers out of the box
- Stores three of each puller
- 111225 – JCPP-200 2t hand cable puller (qty 4)
- 111228 – JCPP-400d 4t hand cable puller (qty 4)
- 890631 – Puller display rack (in box) (qty 1)
- 890695 – Sign for JCCPP-8 display (qty 1)



MATERIAL HANDLING RACK

890157 / MHDR-2

- Rugged heavy gauge steel construction
- Holds up to 6 pullers/chain hoists
- 30" wide x 30" deep x 82" high (rack only)
- Product not included



STRONGARM® SERVICE JACK DISPLAY

038703K / 395

- Constructed of heavy gauge steel
- Side pocket for storing handles
- Comes with header card (039236)



STRONGARM® BOTTLE JACK DISPLAY

038710K / 399

- Constructed of heavy duty gauge steel
- Black checker plate finish
- Comes with header card (039236)
- Load bottom to top ensuring heavier items are on the bottom shelf
- Maximum shelf load 80 lb (36 kg)
- Product not included





CLOTHES HANGER

V6040600 / 103121

- 19" deluxe wishbone hanger
- Special wide shoulder design
- Pioneer logo
- Black



WATERFALL DISPLAY BAR

V6040700 / 171001

- 6-ball waterfall
- Fits in slat wall
- Ideal for wall clothing displays on slat wall
- Black



MIRROR

V6042600 / TM24X49

- Pre-owned
- Clips to attach to display racks
- Width: 24" Height: 49"



CLOTHING DISPLAY RACK

V6041000 / 210001

- Collapsible
- 1" (2.5 cm) chrome tubing
- 50" (127 cm) hang rail with a 12" (30.5 cm) pull-out extension at each end
- 4 wheels
- Can fold down flat or be reassembled in less than a minute
- Height: Adjustable 55" - 65"



MAGIC ROLLING DUFFEL BAG WITH LOGOS

V6061000 / XY106

- Tough 900D oxford polyester
- Hard ABS plastic bottom compartment and frame
- Retractable pull handle, padded top handle, side handles
- Zippered side pocket, gusseted side compartment
- Large main zippered compartment
- Durable oversize wheels
- Dimensions: 28"L x 13"H x 14.5"W
- Colour: black



MERCHANDISING TORSO

V860901

ADJUSTABLE 2-SIDED CLOTHING DISPLAY RACK WITH WHEELS

- Pre-owned
- 4 or 8 bars

PROD. NO.	MOD. NO.	Width	Height
V6042100	T4WR12	12" (30.5 cm)	Adjustable 59" to 79" (150 cm to 201 cm)
V6042200	T4WR25	25" (63.5 cm)	Adjustable 59" to 79" (150 cm to 201 cm)



ADJUSTABLE 2-SIDED CLOTHING DISPLAY RACK WITH WHEELS

- Pre-owned
- 6 or 12 bars
- 1 or 2 clothes hanging levels

PROD. NO.	MOD. NO.	Width	Height
V6042300	T4WR37	37" (94 cm)	Adjustable 59" to 79" (150 cm to 201 cm)
V6042400	T4WR49	49" (126 cm)	Adjustable 59" to 79" (150 cm to 201 cm)



ADJUSTABLE PREMIUM 2-SIDED CLOTHING DISPLAY SHELVES

- Pre-owned
- 10 adjustable height shelves

PROD. NO.	MOD. NO.	Width	Height
V6042500	T4WS49	49" (126 cm)	61" (155 cm)



011704.....	711	021007.....	693	022278.....	687	025060.....	681	025365.....	682	025590.....	681
011708.....	712	021009.....	693	022280.....	687	025061.....	681	025366.....	682	025591.....	681
011712.....	712	021012.....	693	022281.....	687	025062.....	681	025367.....	682	025592.....	681
011903.....	712	021014.....	693	022283.....	687	025064.....	681	025368.....	682	025594.....	681
011981.....	712	021019.....	693	022286.....	687	025066.....	681	025369.....	682	025595.....	681
013480.....	710	021023.....	693	022288.....	687	025104.....	682	025390.....	681	026504.....	698
013485.....	710	021024.....	693	022289.....	687	025105.....	682	025391.....	681	026702.....	698
020113.....	678	021027.....	693	022291.....	687	025106.....	682	025392.....	681	027018.....	700
020123.....	678	021032.....	693	022293.....	687	025107.....	682	025393.....	681	027021.....	700
020124.....	678	021033.....	693	022295.....	687	025108.....	682	025395.....	681	027022.....	700
020125.....	679	021502.....	694	022611.....	697	025109.....	682	025412.....	681	027105.....	702
020133.....	679	021507.....	694	022612.....	697	025110.....	682	025414.....	681	027108.....	702
020134.....	679	021513.....	694	022621.....	697	025111.....	682	025416.....	681	027115.....	702
020135.....	680	021514.....	694	022622.....	697	025112.....	682	025418.....	681	027116.....	702
020141.....	680	021515.....	694	022623.....	697	025154.....	682	025420.....	681	027117.....	702
020202.....	685	021801.....	688	022624.....	697	025155.....	682	025422.....	681	027201.....	705
020203.....	685	021811.....	688	022651.....	697	025156.....	682	025424.....	681	027202.....	705
020207.....	686	022010.....	699	022652.....	697	025157.....	682	025426.....	681	027203.....	705
020208.....	686	022020.....	699	022653.....	697	025158.....	682	025428.....	681	027251.....	705
020210.....	685	022201.....	687	022654.....	697	025159.....	682	025430.....	681	027252.....	705
020211.....	685	022202.....	687	022655.....	697	025160.....	682	025432.....	681	027253.....	705
020215.....	684	022203.....	687	022656.....	697	025161.....	682	025434.....	681	027255.....	705
020216.....	684	022204.....	687	022657.....	697	025162.....	682	025436.....	681	027261.....	704
020217.....	684	022205.....	687	022904.....	696	025190.....	681	025440.....	681	027262.....	704
020219.....	686	022206.....	687	022905.....	696	025191.....	681	025464.....	681	027265.....	704
020222.....	686	022207.....	687	022914.....	696	025193.....	681	025466.....	681	027290.....	701
020236.....	689	022208.....	687	022915.....	696	025195.....	681	025468.....	681	027291.....	701
020304.....	680	022209.....	687	022917.....	696	025212.....	681	025470.....	681	027292.....	701
020312.....	689	022210.....	687	022920.....	696	025214.....	681	025472.....	681	027293.....	701
020313.....	689	022211.....	687	022925.....	696	025216.....	681	025474.....	681	027294.....	701
020314.....	689	022212.....	687	022930.....	704	025218.....	681	025476.....	681	027295.....	701
020402.....	688	022213.....	687	022937.....	696	025220.....	681	025478.....	681	027405.....	704
020404.....	688	022214.....	687	023005.....	700	025222.....	681	025480.....	681	027515.....	699
020405.....	688	022215.....	687	023151.....	700	025224.....	681	025482.....	681	027535.....	699
020406.....	688	022217.....	687	023502.....	695	025226.....	681	025484.....	681	027541.....	699
020407.....	688	022218.....	687	023505.....	695	025228.....	681	025486.....	681	027551.....	699
020415.....	688	022219.....	687	023508.....	695	025262.....	681	025490.....	681	027591.....	698
020416.....	688	022220.....	687	024205.....	699	025264.....	681	025510.....	682	027705.....	698
020417.....	688	022221.....	687	024207.....	699	025266.....	681	025511.....	682	028013.....	710
020504.....	690	022223.....	687	024302.....	703	025268.....	681	025512.....	682	028014.....	710
020505.....	690	022224.....	687	024303.....	703	025270.....	681	025513.....	682	028018.....	710
020506.....	690	022225.....	687	024312.....	703	025272.....	681	025514.....	682	028212.....	706
020514.....	690	022226.....	687	024402.....	700	025274.....	681	025515.....	682	028271.....	709
020515.....	690	022227.....	687	024403.....	700	025276.....	681	025516.....	682	028272.....	709
020516.....	690	022229.....	687	024404.....	700	025278.....	681	025517.....	682	028281.....	709
020604.....	691	022231.....	687	024406.....	700	025306.....	682	025518.....	682	028282.....	709
020606.....	691	022233.....	687	024407.....	700	025307.....	682	025519.....	682	028291.....	709
020608.....	691	022235.....	687	024724.....	700	025308.....	682	025520.....	682	028292.....	709
020626.....	691	022237.....	687	024726.....	700	025309.....	682	025521.....	682	028304.....	706
020627.....	691	022251.....	687	024728.....	700	025310.....	682	025522.....	682	028306.....	706
020628.....	691	022252.....	687	024827.....	711	025311.....	682	025523.....	682	028312.....	707
020629.....	691	022253.....	687	024837.....	711	025312.....	682	025524.....	682	028314.....	707
020630.....	691	022254.....	687	024851.....	711	025313.....	682	025527.....	682	028317.....	707
020631.....	691	022255.....	687	024858.....	711	025314.....	682	025530.....	682	028322.....	708
020722.....	683	022256.....	687	024861.....	710	025315.....	682	025532.....	682	028342.....	708
020727.....	683	022257.....	687	024903.....	703	025316.....	682	025560.....	682	028357.....	708
020732.....	683	022258.....	687	025006.....	681	025317.....	682	025562.....	682	028381.....	708
020737.....	683	022259.....	687	025007.....	681	025318.....	682	025563.....	682	030102.....	616
020802.....	689	022260.....	687	025008.....	681	025319.....	682	025564.....	682	030103.....	616
020803.....	689	022262.....	687	025009.....	681	025320.....	682	025565.....	682	030104.....	616
020804.....	689	022263.....	687	025010.....	681	025321.....	682	025566.....	682	030105.....	616
020805.....	689	022264.....	687	025011.....	681	025322.....	682	025567.....	682	030106.....	616
020906.....	692	022266.....	687	025012.....	681	025358.....	682	025568.....	682	030107.....	616
020907.....	692	022267.....	687	025014.....	681	025359.....	682	025569.....	682	030110.....	616
020911.....	692	022269.....	687	025016.....	681	025360.....	682	025570.....	682	030111.....	616
020921.....	692	022271.....	687	025056.....	681	025361.....	682	025571.....	682	030112.....	616
021002.....	693	022272.....	687	025057.....	681	025362.....	682	025572.....	682	030114.....	616
021003.....	693	022275.....	687	025058.....	681	025363.....	682	025573.....	682	030115.....	616
021005.....	693	022277.....	687	025059.....	681	025364.....	682	025574.....	682	030152.....	618

030157.....	618	030502.....	631	033130.....	662	101416.....	569	111228.....	581	290791.....	612
030158.....	618	030503.....	631	033131.....	662	101422.....	569	113261.....	588	290792.....	612
030173.....	620	030504.....	631	033132.....	662	101426.....	569	113263.....	588	291001.....	598
030174.....	620	030505.....	631	033137.....	662	101432.....	569	113264.....	588	291005.....	598
030175.....	620	030506.....	631	033138.....	662	101436.....	569	120251.....	585	291007.....	599
030176.....	620	030507.....	631	033139.....	662	101452.....	569	120252.....	585	291008.....	600
030178.....	620	030508.....	631	033140.....	662	101456.....	569	120253.....	585	291009.....	599
030179.....	620	030509.....	631	033141.....	662	101462.....	569	120254.....	585	291011.....	600
030182.....	620	030510.....	631	033142.....	662	101466.....	569	120255.....	585	291031.....	607
030183.....	620	030511.....	631	033150.....	663	107202.....	556	120256.....	585	291033.....	607
030186.....	620	030522.....	637	033151.....	663	107203.....	556	120257.....	585	291035.....	607
030192.....	619	030524.....	637	033152.....	663	107204.....	556	120362.....	584	291037.....	607
030195.....	619	030527.....	638	033153.....	663	107205.....	556	120364.....	584	291038.....	607
030202.....	648	030529.....	638	033154.....	663	107206.....	556	120365.....	584	291039.....	607
030207.....	648	030532.....	638	033155.....	663	107212.....	556	120366.....	584	291056.....	608
030212.....	650	030545.....	639	033156.....	663	107213.....	556	120367.....	584	291058.....	608
030215.....	650	030547.....	639	033160.....	662	107214.....	556	120603.....	583	291060.....	608
030230.....	648	030549.....	639	033165.....	662	107215.....	556	120605.....	583	291061.....	609
030232.....	651	032161.....	646	101002.....	560	107216.....	556	120606.....	583	291062.....	609
030234.....	651	032166.....	646	101006.....	560	107262.....	556	120607.....	583	291066.....	608
030235.....	651	032173.....	647	101012.....	560	107263.....	556	124202.....	585	291067.....	608
030239.....	651	032175.....	647	101016.....	560	107264.....	556	124203.....	585	291068.....	608
030240.....	651	032181.....	644	101032.....	560	107265.....	556	124204.....	585	291069.....	608
030241.....	651	032182.....	644	101036.....	560	107266.....	556	124205.....	585	291080.....	610
030242.....	648, 651	032184.....	644	101102.....	562	109302.....	586	124206.....	585	291083.....	610
030250.....	649	032185.....	645	101106.....	562	109304.....	586	124207.....	585	291085.....	610
030283.....	650	032187.....	645	101112.....	562	109305.....	586	124208.....	585	291087.....	610
030284.....	648, 650	032202.....	634	101116.....	562	109322.....	586	130103.....	587	291101.....	596
030292.....	651	032204.....	634	101132.....	562	109323.....	586	130104.....	587	291103.....	596
030303.....	641	032206.....	634	101136.....	562	109325.....	586	130105.....	587	291105.....	597
030315.....	641	032211.....	634	101142.....	562	109327.....	586	130106.....	587	291107.....	597
030321.....	642	032215.....	633	101146.....	562	109392.....	586	130108.....	587	291109.....	596
030341.....	642	032216.....	633	101152.....	562	110241.....	579	130203.....	587	291400.....	603
030342.....	642	032217.....	633	101156.....	562	110242.....	579	130204.....	587	291401.....	606
030352.....	640	032222.....	636	101162.....	562	110243.....	579	131104.....	587	291402.....	606
030353.....	640	032226.....	635	101172.....	562	110244.....	579	131105.....	587	291403.....	606
030371.....	651	032228.....	635	101202.....	567	110302.....	573	131106.....	587	291405.....	601
030381.....	651	032229.....	636	101204.....	567	110303.....	573	131108.....	587	291406.....	601
030406.....	622	032241.....	636	101206.....	567	110304.....	573	133103.....	587	291407.....	603
030407.....	622	032243.....	636	101212.....	567	110402.....	574	133104.....	587	291408.....	602
030412.....	621	032246.....	636	101214.....	567	110403.....	574	133105.....	587	291409.....	602
030414.....	621	033001.....	655	101216.....	567	110404.....	574	133106.....	587	291410.....	602
030415.....	621	033005.....	655	101222.....	567	110405.....	574	133108.....	587	291411.....	602
030434.....	623	033010.....	655	101224.....	567	110406.....	574	140101.....	617	291412.....	601
030436.....	623	033011.....	655	101226.....	567	110407.....	574	140102.....	617	291413.....	601
030438.....	623	033012.....	655	101232.....	567	110408.....	574	140103.....	617	291415.....	601
030439.....	623	033013.....	655	101234.....	567	110412.....	574	140104.....	617	291416.....	605
030442.....	618	033014.....	655	101236.....	567	110413.....	574	140105.....	617	291417.....	605
030445.....	624	033035.....	655	101252.....	567	110414.....	574	140106.....	617	291418.....	604
030448.....	624	033036.....	655	101254.....	567	110506.....	576	140107.....	617	291419.....	605
030450.....	625	033037.....	655	101256.....	567	110507.....	576	140108.....	617	291420.....	604
030454.....	629	033038.....	655	101262.....	567	110509.....	576	140109.....	617	291421.....	603
030457.....	629	033039.....	655	101264.....	567	110510.....	576	140110.....	617	291422.....	605
030458.....	630	033050.....	655	101266.....	567	110512.....	576	140111.....	617	291423.....	605
030461.....	623	033060.....	655	101283.....	567	110513.....	576	140112.....	617	291424.....	604
030466.....	623	033061.....	657	101292.....	567	110515.....	576	190918.....	222, 589	291426.....	604
030472.....	628	033063.....	657	101302.....	564	110803.....	574	190968.....	223, 589	291427.....	602
030473.....	628	033065.....	657	101306.....	564	110804.....	574	200225.....	231	291475.....	611
030474.....	626	033070.....	657	101312.....	564	110903.....	577	200275.....	231	291476.....	611
030475.....	626	033074.....	657	101316.....	564	110904.....	577	200278.....	232	291477.....	611
030476.....	627	033076.....	659	101332.....	564	111136.....	580	200357.....	233	291478.....	611
030477.....	627	033077.....	659	101336.....	564	111137.....	580	222326.....	234	291479.....	611
030481.....	633	033078.....	659	101342.....	564	111138.....	580	222332.....	234	291480.....	611
030482.....	630	033079.....	659	101346.....	564	111152.....	580	222335.....	235	310006.....	322
030483.....	632	033101.....	661	101352.....	564	111153.....	580	240153.....	230	310008.....	322
030484.....	632	033102.....	661	101356.....	564	111154.....	580	240154.....	230	310016.....	321
030485.....	632	033125.....	660	101402.....	569	111162.....	580	290771.....	612	310018.....	321
030487.....	632	033126.....	660	101406.....	569	111163.....	580	290774.....	612	310022.....	323
030501.....	631	033127.....	660	101412.....	569	111225.....	581	290784.....	612	310041.....	323

310122	316	350185	247	390123	215	400245	470	404424	504	408856	534
310131	316	350189	247	390124	215	400246	470	404606	500	408857	534
310132	316	350201	245	390125	215	400247	471	408104	548	408858	534
310133	316	350202	245	390126	215	400252	469	408105	548	408861	536
310136	316	350203	247	390127	215	400256	469	408123	549	408862	536
310206	318	350204	247	390129	215	400261	472	408128	549	408863	536
310210	318	350205	246	390142	214	400266	471	408132	548	408864	536
310211	318	350206	246	390143	214	400310	474	408136	548	408865	536
310212	318	350207	247	390144	214	400312	473	408137	548	408866	536
310213	318	350208	246	390145	214	400313	474	408142	548	408867	536
310223	318	350209	246	390146	214	400340	475	408160	549	408868	536
310501	317	350210	246	390151	214	400424	476	408171	548	408871	529
310502	317	350211	246	390153	214	400426	478	408201	510	408872	529
310511	319	350212	246	390155	214	400427	478	408202	510	408873	529
310602	320	350213	246	390157	214	400434	477	408207	510	408874	529
310603	320	350214	260	390202	216	400435	476	408213	510	408875	529
310604	320	350215	245	390204	216	400443	479	408214	510	408878	529
310605	320	350216	245	390206	216	400444	479	408221	510	408879	529
310902	317	350217	247	390208	216	400455	480	408222	510	408881	531
310903	317	350218	247	390210	216	400456	480	408223	510	408882	531
310905	317	350251	249	390212	216	402109	484	408224	510	408883	531
320151	219	350252	249	390224	216	402110	484	408225	510	408884	531
320152	219	350253	249	390226	216	402113	487	408226	510	408885	531
320153	219	350254	249	390228	216	402114	487	408227	510	408888	531
320154	219	350255	249	390230	216	402115	488	408228	510	408889	531
320312	220	350256	249	390232	216	402116	489	408231	510	408891	536
320313	220	350257	248	390233	216	402118	485	408232	510	408892	536
320314	220	350258	248	390248	217	402120	485	408281	510	408893	536
320315	220	350259	248	390250	217	402121	488	408283	510	408894	536
320316	220	350260	248	390252	217	402123	489	408291	509	409005	498
320317	220	350261	249	390254	217	402124	489	408292	509	409007	499
320318	220	350262	249	390292	217	402149	484	408312	514	409008	499
320319	220	350263	248	390293	217	402304	490	408315	514	409009	498
321124	221	350264	248	390294	217	402305	490	408331	514	409012	493
321336	221	350265	249	390295	217	402312	491	408332	514	409014	494
350103	255	350306	250	390296	217	402313	491	408335	514	409015	493
350105	254	350307	250	390297	217	402332	492	408352	514	409016	494
350106	254	350311	251	390298	217	402333	492	408355	514	409042	500
350107	257	350312	251	390299	217	403095	516	408401	513	409123	523, 524
350108	252	350391	251	390457	218	403102	517	408402	512, 513	409124	522, 524
350109	252	350511	258	390458	218	403112	517	408403	513	409128	523
350110	252	350512	258	391103	197	403192	516	408406	513	409131	511
350111	252	350514	259	391104	197	403201	519	408407	513	409132	511
350112	252	350515	259	391106	197	403203	519	408801	532	409141	497
350113	253	350520	259	391107	197	403212	518	408802	532	409902	544
350114	255	350551	259	391109	197	403217	518	408804	532	409903	543
350115	255	351003	260	391110	197	403351	520	408808	532	409904	543
350116	256	351004	260	391721	546	403355	520	408809	532	409905	543
350117	256	351005	260	391722	546	404123	508	408811	536	409908	544
350118	257	351011	260	391723	546	404124	508	408812	524	409910	544
350121	253	355002	224	391726	546	404126	509	408813	536	409913	544
350122	253	355008	224	391728	546	404153	496	408814	536	409916	543
350124	253	355091	224	391729	547	404163	496	408816	524	409918	543
350125	253	355105	225	391730	547	404203	512	408817	528	409920	543
350151	242	355115	225	391739	547	404208	512	408818	528	420001	540
350152	242	355130	225	391741	547	404213	512	408821	528	420002	540
350155	242	355153	226	391742	547	404226	513	408823	528	420051	540
350156	243	355158	226	391746	546	404228	513	408825	528	420052	540
350157	254	355191	227	400007	481	404313	514	408826	528	420091	540
350158	250	355193	227	400104	467	404323	514	408828	528	420092	540
350159	254	390102	215	400105	466	404324	514	408831	530	420101	540
350161	244	390103	215	400108	481	404328	514	408832	536	420102	540
350162	244	390104	215	400109	481	404329	514	408833	530	420151	540
350165	243	390105	215	400116	466	404412	503	408836	530	420152	540
350166	243	390106	215	400140	468	404415	502	408842	530	420301	541
350171	244	390108	215	400213	482	404418	505	408847	530	420302	541
350173	244	390110	215	400214	482	404419	503	408849	530	420351	541
350181	245	390112	215	400226	470	404422	504	408852	534	420352	541
350182	245	390122	215	400240	471	404423	504	408855	534	420391	541

420601.....	541	500725.....	354	501531.....	355	502147.....	391	503215.....	386	522273.....	230, 379
420602.....	541	500726.....	376	501533.....	355	502148.....	391	503217.....	386	522274.....	230, 379
420651.....	541	500803.....	376	501537.....	355	502150.....	391	503219.....	386	522275.....	230, 379
420652.....	541	500805.....	376	501538.....	355	502152.....	391	503223.....	386	522313.....	379
420691.....	541	500918.....	378	501570.....	356	502172.....	391	503225.....	386	522314.....	379
420901.....	540	500928.....	378	501571.....	356	502174.....	391	503227.....	386	522315.....	379
420902.....	540	500932.....	378	501572.....	356	502176.....	391	503229.....	386	522333.....	379
420951.....	540	500938.....	378	501575.....	356	502182.....	391	503231.....	386	522334.....	379
421251.....	542	500948.....	378	501576.....	356	502184.....	391	503233.....	386	522335.....	379
421252.....	542	501002.....	352	501577.....	356	502186.....	391	503235.....	386	522372.....	379
421501.....	542	501004.....	352	501581.....	356	502255.....	403	503237.....	386	522373.....	379
421551.....	542	501011.....	352	501582.....	356	502257.....	403	503238.....	386	522374.....	379
421601.....	542	501012.....	352	501586.....	356	502259.....	403	503240.....	386	522375.....	379
421651.....	542	501014.....	352	501621.....	355	502260.....	403	503242.....	386	522406.....	380
422001.....	540	501017.....	352	501622.....	355	502262.....	403	503244.....	386	522407.....	380
422002.....	540	501022.....	352	501626.....	355	502264.....	403	503313.....	388	522409.....	380
422051.....	540	501043.....	352	501627.....	355	502275.....	404	503315.....	388	522411.....	380
422601.....	541	501044.....	352	501631.....	355	502277.....	404	503317.....	388	522412.....	380
422602.....	541	501052.....	353	501632.....	355	502279.....	404	503319.....	388	522414.....	380
422651.....	541	501054.....	353	501636.....	355	502285.....	404	503413.....	387	522436.....	380
500211.....	397	501057.....	353	501653.....	372	502287.....	404	503415.....	387	522437.....	380
500212.....	397	501061.....	353	501656.....	372	502289.....	404	503417.....	387	522439.....	380
500221.....	397	501062.....	353	501670.....	356	502332.....	392	503419.....	387	522502.....	380
500222.....	397	501063.....	353	501671.....	356	502333.....	392	503423.....	387	522506.....	380
500241.....	397	501064.....	353	501672.....	356	502343.....	404, 519	503425.....	387	522514.....	380
500242.....	397	501065.....	353	501675.....	356	502345.....	404, 519	503427.....	387	523201.....	381
500322.....	357	501066.....	353	501676.....	356	502352.....	398, 519	503429.....	387	523206.....	381
500327.....	357	501067.....	353	501677.....	356	502353.....	398, 519	503513.....	400	523211.....	381
500332.....	357	501072.....	353	501681.....	356	502354.....	398, 519	503515.....	400	523216.....	381
500337.....	357	501082.....	359	501682.....	356	502372.....	398	503517.....	400	523217.....	381
500405.....	372	501087.....	359	501686.....	356	502373.....	398	503523.....	400	523221.....	381
500408.....	377	501134.....	362	501705.....	357	502402.....	396	503525.....	400	523226.....	381
500412.....	355	501143.....	362	501708.....	357	502403.....	396	503527.....	400	523303.....	382
500415.....	372	501146.....	362	501711.....	357	502404.....	396	503605.....	402	523309.....	382
500418.....	377	501149.....	362	501715.....	357	502406.....	396	503609.....	402	523436.....	382
500422.....	355	501152.....	363	501722.....	357	502408.....	396	503624.....	402	523439.....	382
500425.....	372	501153.....	363	501727.....	357	502411.....	396	503634.....	402	523440.....	382
500428.....	377	501154.....	363	501732.....	357	502412.....	396	503654.....	402	523446.....	382
500431.....	372	501166.....	363	501737.....	357	502413.....	396	503682.....	402	523449.....	382
500432.....	377	501207.....	359	501805.....	354	502414.....	396	503684.....	402	523450.....	382
500435.....	372	501209.....	359	501808.....	354	502415.....	396	503689.....	403	523454.....	382
500438.....	377	501217.....	359	501811.....	354	502416.....	396	503692.....	403	523455.....	382
500445.....	372	501220.....	360	501815.....	354	502418.....	396	503694.....	403	523480.....	382
500448.....	377	501221.....	360	502011.....	390	502418.....	396	503699.....	403	530106.....	445
500465.....	373	501222.....	360	502013.....	390	502421.....	396	503865.....	389	530107.....	445
500468.....	377	501223.....	360	502015.....	390	502422.....	396	503875.....	389	530108.....	445
500475.....	373	501224.....	360	502017.....	390	502423.....	396	503915.....	388	530116.....	444
500478.....	377	501225.....	360	502017.....	390	502424.....	396	503925.....	388	530117.....	444
500481.....	373	501225.....	360	502021.....	390	502425.....	396	510100.....	381	530118.....	444
500482.....	377	501226.....	360	502023.....	390	502426.....	396	510110.....	381	530118.....	444
500485.....	373	501227.....	360	502025.....	390	502428.....	396	510120.....	381	530120.....	444
500488.....	377	501228.....	360	502027.....	390	502441.....	396	510150.....	381	530208.....	437
500511.....	358	501229.....	360	502061.....	390	502442.....	396	510215.....	381	530214.....	437
500518.....	378	501233.....	364	502063.....	390	502443.....	396	510275.....	381	530216.....	437
500525.....	358	501243.....	364	502065.....	390	502444.....	396	510285.....	381	530217.....	437
500528.....	378	501283.....	364	502067.....	390	502445.....	396	510290.....	381	530218.....	437
500535.....	358	501293.....	364	502071.....	390	502446.....	396	510524.....	381	530219.....	437
500538.....	378	501320.....	360	502073.....	390	502448.....	396	510556.....	381	530220.....	437
500561.....	358	501326.....	360	502075.....	390	502450.....	397	522163.....	230, 379	530221.....	437
500568.....	378	501328.....	360	502077.....	390	502507.....	397	522164.....	230, 379	530222.....	437
500575.....	358	501336.....	364	502122.....	391	502508.....	397	522165.....	230, 379	530223.....	437
500578.....	378	501346.....	364	502124.....	391	502512.....	397	522173.....	230, 379	530224.....	437
500588.....	378	501355.....	361	502126.....	391	502513.....	397	522174.....	230, 379	530225.....	437
500711.....	354	501356.....	361	502127.....	391	502514.....	397	522175.....	230, 379	530226.....	437
500712.....	376	501370.....	361	502128.....	391	502527.....	397	522176.....	230, 379	530227.....	437
500715.....	354	501371.....	361	502130.....	391	502528.....	397	522224.....	379	530228.....	437
500716.....	376	501521.....	355	502132.....	391	502529.....	397	522225.....	379	530229.....	437
500719.....	354	501523.....	355	502142.....	391	502997.....	392	522263.....	230, 379	530230.....	437
500720.....	376	501526.....	355	502144.....	391	502998.....	392	522264.....	230, 379	530231.....	437
		501528.....	355	502146.....	391	503213.....	386	522265.....	230, 379	530232.....	437

530233.....	437	530376.....	437	530734.....	441	531205.....	454	531928.....	452	533605.....	424
530234.....	437	530401.....	439	530736.....	441	531206.....	454	531930.....	452	533625.....	424
530235.....	437	530402.....	439	530738.....	441	531207.....	454	531946.....	452	533655.....	424
530236.....	437	530403.....	439	530740.....	441	531306.....	451	531948.....	452	533704.....	424
530237.....	437	530404.....	439	530741.....	441	531308.....	451	531950.....	452	533904.....	423
530238.....	437	530406.....	439	530753.....	441	531310.....	451	532008.....	455	533907.....	423
530239.....	437	530408.....	439	530755.....	441	531312.....	451	532048.....	455	533912.....	423
530240.....	437	530409.....	439	530759.....	441	531314.....	451	532112.....	455	534004.....	421
530241.....	437	530410.....	439	530772.....	441	531326.....	451	532206.....	457	534008.....	421
530242.....	437	530412.....	439	530774.....	441	531328.....	451	532211.....	457	534012.....	421
530243.....	437	530509.....	438	530776.....	441	531330.....	451	532212.....	457	534034.....	421
530244.....	437	530512.....	438	530778.....	441	531332.....	451	532216.....	457	534038.....	421
530245.....	437	530514.....	438	530780.....	441	531334.....	451	532217.....	457	534042.....	421
530246.....	437	530520.....	438	530783.....	441	531346.....	451	532218.....	457	534049.....	421
530247.....	437	530521.....	438	530784.....	441	531348.....	451	532226.....	457	534053.....	421
530248.....	437	530522.....	438	530786.....	441	531350.....	451	532227.....	457	534057.....	421
530252.....	437	530524.....	438	530788.....	441	531352.....	451	532228.....	457	534068.....	421
530253.....	437	530527.....	438	530803.....	442	531354.....	451	532231.....	457	534072.....	421
530254.....	437	530530.....	438	530805.....	442	531406.....	451	532232.....	457	534079.....	421
530258.....	437	530533.....	438	530807.....	442	531408.....	451	532233.....	457	534087.....	421
530259.....	437	530535.....	438	530811.....	442	531410.....	451	532246.....	457	534094.....	421
530260.....	437	530536.....	438	530815.....	442	531412.....	451	532247.....	457	534098.....	421
530264.....	437	530537.....	438	530817.....	442	531414.....	451	532248.....	457	534102.....	421
530265.....	437	530539.....	438	530819.....	442	531426.....	451	532261.....	457	534155.....	421
530266.....	437	530541.....	438	530821.....	442	531428.....	451	532262.....	457	534158.....	421
530270.....	437	530542.....	438	530822.....	442	531430.....	451	532263.....	457	534161.....	421
530271.....	437	530543.....	438	530823.....	442	531432.....	451	532502.....	455	534174.....	421
530272.....	437	530544.....	438	530825.....	442	531434.....	451	532522.....	453	534177.....	421
530276.....	437	530545.....	438	530826.....	442	531446.....	451	532524.....	453	534192.....	421
530282.....	437	530546.....	438	530827.....	442	531448.....	451	532542.....	453	534401.....	424
530308.....	437	530547.....	438	530831.....	442	531450.....	451	532811.....	456	534403.....	424
530314.....	437	530548.....	438	530834.....	442	531452.....	451	532851.....	456	534405.....	424
530319.....	437	530549.....	438	530835.....	442	531454.....	451	532922.....	457	534421.....	424
530320.....	437	530551.....	438	530838.....	442	531506.....	452	532924.....	457	534423.....	424
530321.....	437	530553.....	438	530839.....	442	531508.....	452	532926.....	457	534425.....	424
530325.....	437	530554.....	438	530841.....	442	531510.....	452	532929.....	457	534451.....	424
530326.....	437	530555.....	438	530843.....	442	531512.....	452	533301.....	422	534453.....	424
530327.....	437	530560.....	438	530845.....	442	531514.....	452	533303.....	422	534455.....	424
530328.....	437	530566.....	438	530846.....	442	531526.....	452	533305.....	422	550121.....	230, 406
530329.....	437	530572.....	438	530853.....	442	531528.....	452	533306.....	422	550123.....	230, 406
530330.....	437	530573.....	438	530857.....	442	531530.....	452	533311.....	422	550124.....	230, 406
530331.....	437	530609.....	438	530861.....	442	531548.....	452	533313.....	422	550125.....	230, 406
530332.....	437	530614.....	438	530865.....	442	531550.....	452	533315.....	422	550131.....	406
530333.....	437	530621.....	438	530867.....	442	531552.....	452	533316.....	422	550133.....	406
530334.....	437	530623.....	438	530869.....	442	531606.....	453	533321.....	422	550141.....	230, 406
530335.....	437	530624.....	438	530871.....	442	531608.....	453	533323.....	422	550142.....	230, 406
530336.....	437	530625.....	438	530873.....	442	531610.....	453	533325.....	422	550143.....	230, 406
530337.....	437	530627.....	438	530877.....	442	531612.....	453	533326.....	422	550145.....	406
530338.....	437	530629.....	438	530903.....	443	531626.....	453	533331.....	422	550151.....	406
530339.....	437	530630.....	438	530904.....	443	531628.....	453	533333.....	422	550152.....	406
530340.....	437	530631.....	438	530905.....	443	531630.....	453	533335.....	422	550154.....	406
530341.....	437	530633.....	438	530906.....	443	531632.....	453	533341.....	422	550165.....	406
530342.....	437	530635.....	438	530908.....	443	531646.....	453	533343.....	422	550166.....	406
530343.....	437	530636.....	438	530910.....	443	531648.....	453	533351.....	422	550303.....	416
530344.....	437	530637.....	438	530951.....	443	531650.....	453	533353.....	422	550306.....	416
530345.....	437	530641.....	438	530952.....	443	531652.....	453	533355.....	422	550310.....	416
530346.....	437	530642.....	438	530955.....	439	531806.....	454	533361.....	422	550701.....	417
530347.....	437	530643.....	438	530956.....	439	531808.....	454	533363.....	422	550702.....	417
530348.....	437	530703.....	441	530957.....	439	531810.....	454	533365.....	422	550802.....	416
530352.....	437	530705.....	441	530960.....	440	531826.....	454	533395.....	422	550905.....	417
530353.....	437	530707.....	441	530961.....	440	531828.....	454	533402.....	422	550906.....	417
530354.....	437	530709.....	441	530965.....	443	531830.....	454	533403.....	422	551101.....	407
530358.....	437	530712.....	441	530966.....	443	531846.....	454	533404.....	422	551102.....	407
530364.....	437	530722.....	441	530981.....	440	531848.....	454	533414.....	422	551104.....	407
530365.....	437	530724.....	441	530984.....	440	531850.....	454	533415.....	422	551105.....	407
530366.....	437	530726.....	441	530991.....	440	531906.....	452	533416.....	422	551109.....	407
530370.....	437	530728.....	441	530994.....	440	531908.....	452	533422.....	422	551111.....	407
530371.....	437	530730.....	441	531128.....	454	531910.....	452	533423.....	422	551112.....	407
530372.....	437	530732.....	441	531130.....	454	531926.....	452	533425.....	422	551117.....	407

551120.....	407	560127.....	393	565110.....	446	568643.....	366	570266.....	431	570619.....	428
552112.....	407	560152.....	393	565115.....	446	568645.....	367	570267.....	431	570620.....	428
552113.....	407	560153.....	393	565117.....	446	568652.....	366	570268.....	431	570621.....	428
552114.....	407	560155.....	393	565119.....	446	568655.....	367	570269.....	431	570622.....	428
552115.....	407	560172.....	393	565121.....	446	568661.....	368	570270.....	431	570623.....	428
552116.....	407	560173.....	393	565123.....	446	568663.....	366	570271.....	431	570624.....	428
552118.....	407	560175.....	393	565125.....	446	568666.....	367	570272.....	431	570625.....	428
552119.....	407	560212.....	393	565126.....	446	568729.....	368	570273.....	431	570626.....	428
553015.....	415	560213.....	393	565128.....	446	568739.....	368	570274.....	431	570627.....	428
553025.....	415	560215.....	393	565129.....	446	568812.....	369	570275.....	431	570628.....	428
553302.....	414	560222.....	393	565131.....	446	568814.....	369	570276.....	431	570629.....	428
553322.....	414	560223.....	393	565132.....	446	568815.....	369	570277.....	431	570630.....	428
553324.....	414	560225.....	393	565135.....	446	568824.....	369	570278.....	431	570631.....	428
553327.....	414	560272.....	393	565137.....	446	568825.....	369	570279.....	431	570632.....	428
553328.....	414	560273.....	393	565139.....	446	568826.....	369	570280.....	431	570658.....	429
553332.....	414	560275.....	393	565141.....	446	568827.....	369	570281.....	431	570659.....	429
553401.....	413	560322.....	393	565142.....	446	568836.....	369	570282.....	431	570660.....	429
553411.....	413	560323.....	393	565145.....	446	569801.....	369	570358.....	432	570661.....	429
553432.....	413	560325.....	393	565146.....	446	569806.....	370	570436.....	433	570662.....	429
553434.....	413	560342.....	393	565149.....	446	569811.....	369	570440.....	433	570663.....	429
553436.....	413	560343.....	393	565153.....	446	569816.....	370	570444.....	433	570664.....	429
553441.....	413	560345.....	393	565161.....	446	570108.....	426	570448.....	433	570665.....	429
553451.....	413	564810.....	394	565180.....	447	570141.....	432	570452.....	433	570666.....	429
553452.....	413	564811.....	394	565182.....	447	570142.....	432	570456.....	433	570667.....	429
553462.....	413	564812.....	394	565183.....	447	570143.....	432	570460.....	433	570668.....	429
553501.....	409	564813.....	394	565184.....	447	570144.....	434	570464.....	433	570669.....	429
553502.....	409	564814.....	394	565185.....	447	570146.....	429	570472.....	433	570670.....	429
553505.....	408	564815.....	394	565186.....	447	570147.....	429	570480.....	433	570671.....	429
553507.....	408	564817.....	394	565188.....	447	570204.....	426	570533.....	427	570672.....	429
553509.....	408	564818.....	394	565191.....	447	570205.....	426	570534.....	427	570673.....	429
553518.....	409	564830.....	394	565192.....	447	570206.....	426	570535.....	427	570674.....	429
553605.....	411, 415	564831.....	394	565196.....	447	570207.....	426	570536.....	427	570675.....	429
553606.....	411, 415	564832.....	394	565205.....	448	570208.....	426	570537.....	427	570676.....	429
553607.....	411, 415	564833.....	394	565206.....	448	570209.....	426	570538.....	427	570677.....	429
553652.....	411	564835.....	394	565207.....	448	570210.....	426	570539.....	427	570678.....	429
553655.....	411	564837.....	394	565208.....	448	570211.....	426	570540.....	427	570679.....	429
553683.....	410	564838.....	394	566231.....	211, 458	570212.....	426	570541.....	427	570680.....	429
553701.....	416	564840.....	394	566232.....	211, 458	570213.....	426	570542.....	427	570681.....	429
553712.....	417	564841.....	394	566233.....	211, 458	570214.....	426	570543.....	427	570682.....	429
553713.....	417	564842.....	394	567010.....	366	570215.....	426	570544.....	427	570906.....	431
553714.....	417	564843.....	394	567015.....	366	570216.....	426	570545.....	427	570921.....	431
553716.....	417	564845.....	394	567025.....	366	570217.....	426	570546.....	427	571234.....	430
553722.....	417	564847.....	394	567040.....	366	570218.....	426	570547.....	427	571236.....	430
553733.....	417	564848.....	394	567110.....	367	570219.....	426	570548.....	427	571240.....	430
553735.....	417	564860.....	394	567115.....	367	570220.....	426	570549.....	427	571242.....	430
553742.....	416	564861.....	394	567125.....	367	570221.....	426	570550.....	427	571244.....	430
553792.....	416	564862.....	394	567140.....	367	570222.....	426	570551.....	427	571248.....	430
554100.....	409, 415	564863.....	394	567202.....	370	570223.....	426	570552.....	427	571252.....	430
554102.....	409	564865.....	394	567212.....	370	570224.....	426	570556.....	427	571256.....	430
554103.....	409	564867.....	394	567222.....	370	570225.....	426	570560.....	427	571260.....	430
554105.....	409, 415	564868.....	394	567232.....	370	570226.....	426	570564.....	427	571264.....	430
554106.....	415	564870.....	395	567405.....	368	570227.....	426	570568.....	427	573404.....	434
554107.....	409, 415	564871.....	395	567440.....	368	570228.....	426	570572.....	427	573405.....	434
554115.....	412	564872.....	395	568501.....	383	570229.....	426	570580.....	427	573406.....	434
554121.....	412, 415	564873.....	395	568503.....	383	570230.....	426	570604.....	428	573407.....	434
554126.....	412	564875.....	395	568504.....	383	570231.....	426	570605.....	428	573408.....	434
554201.....	410	564876.....	395	568507.....	383	570232.....	426	570606.....	428	573409.....	434
554202.....	410	564878.....	395	568508.....	383	570254.....	431	570607.....	428	573410.....	434
554203.....	410, 415	564880.....	395	568601.....	368	570255.....	431	570608.....	428	573411.....	434
554207.....	410, 415	564881.....	395	568602.....	366	570256.....	431	570609.....	428	573412.....	434
554305.....	412	564882.....	395	568603.....	367	570257.....	431	570610.....	428	573413.....	434
554309.....	412	564883.....	395	568609.....	366	570258.....	431	570611.....	428	573414.....	434
554311.....	412, 415	564885.....	395	568611.....	367	570259.....	431	570612.....	428	573415.....	434
554316.....	412	564886.....	395	568614.....	368	570260.....	431	570613.....	428	573416.....	434
554434.....	406	564888.....	395	568615.....	366	570261.....	431	570614.....	428	573417.....	434
554455.....	406	565102.....	446	568617.....	367	570262.....	431	570615.....	428	573418.....	434
560122.....	393	565104.....	446	568631.....	368	570263.....	431	570616.....	428	573419.....	434
560123.....	393	565106.....	446	568632.....	366	570264.....	431	570617.....	428	573420.....	434
560125.....	393	565108.....	446	568633.....	367	570265.....	431	570618.....	428	573421.....	434

573422.....	434	601316.....	57	670107.....	64	670806.....	66	671510.....	66	671932.....	64
573423.....	434	601317.....	57	670108.....	64	670807.....	66	671511.....	66	671934.....	64
573424.....	434	601318.....	57	670109.....	64	670808.....	66	671512.....	66	671940.....	341
573425.....	434	601319.....	58	670110.....	64	670809.....	66	671513.....	66	671941.....	41, 341
573426.....	434	601320.....	58	670111.....	64	670810.....	66	671514.....	66	671942.....	38
573427.....	434	601321.....	63	670112.....	64	670811.....	66	671515.....	66	671943.....	38, 340
573428.....	434	601405.....	59	670114.....	64	670812.....	66	671516.....	66	671944.....	41, 341
573429.....	434	601406.....	59	670116.....	64	670901.....	340	671517.....	66	671945.....	38, 340
573430.....	434	601407.....	59	670206.....	64	670902.....	72	671518.....	66	671947.....	75
573431.....	434	601801.....	62	670207.....	64	670904.....	46, 47, 74	671519.....	66	671948.....	75
573432.....	434	601802.....	60	670208.....	64	670905.....	74	671520.....	66	671949.....	75
579202.....	435	601803.....	60	670209.....	64	670906.....	46, 74	671521.....	66	671951.....	76
579204.....	435	601804.....	61	670210.....	64	670907.....	73	671522.....	66	671952.....	76
579206.....	435	601805.....	61	670211.....	64	670908.....	46, 47, 71	671524.....	66	671953.....	76
579208.....	435	601806.....	62	670212.....	64	670911.....	71	671608.....	66	671954.....	76
579212.....	435	601808.....	61	670214.....	64	670912.....	46, 47, 73	671609.....	66	672112.....	65
579214.....	435	601811.....	63	670216.....	64	670913.....	71	671610.....	66	672114.....	65
579326.....	435	610201.....	78	670306.....	64	670915.....	47, 74	671611.....	66	672116.....	65
579328.....	435	610203.....	78	670307.....	64	670921.....	42, 341	671612.....	66	672118.....	65
579330.....	435	610207.....	78	670308.....	64	670922.....	40, 341	671613.....	66	672120.....	65
579333.....	435	610208.....	78	670309.....	64	670926.....	38, 46	671614.....	66	672122.....	65
599001.....	401	610217.....	78	670310.....	64	670927.....	39, 47, 341	671615.....	66	672124.....	65
599002.....	401	610218.....	78	670311.....	64	670928.....	38, 340	671616.....	66	672126.....	65
599004.....	401	610302.....	79	670312.....	64	670929.....	38, 340	671617.....	66	672128.....	65
599006.....	401	610303.....	79	670314.....	64	670930.....	73	671618.....	66	672130.....	65
599008.....	401	610308.....	80	670316.....	64	671108.....	64	671619.....	66	672132.....	65
599021.....	353	610310.....	80	670406.....	64	671110.....	64	671708.....	66	672134.....	65
599024.....	353, 382	610314.....	80	670407.....	64	671112.....	64	671709.....	66	672136.....	65
599033.....	380	610315.....	80	670408.....	64	671114.....	64	671710.....	66	672138.....	65
599045.....	380	610321.....	79	670409.....	64	671116.....	64	671711.....	66	672140.....	65
600115.....	46	610323.....	79	670410.....	64	671118.....	64	671712.....	66	672212.....	65
600116.....	46	610326.....	88	670411.....	64	671120.....	64	671713.....	66	672214.....	65
600125.....	47	610327.....	81	670412.....	64	671122.....	64	671714.....	66	672216.....	65
600126.....	47	610328.....	79	670414.....	64	671124.....	64	671715.....	66	672218.....	65
600223.....	48	610329.....	79	670416.....	64	671126.....	64	671716.....	66	672220.....	65
600226.....	48	610331.....	88	670502.....	66	671128.....	64	671717.....	66	672222.....	65
600229.....	48	610333.....	88	670503.....	66	671130.....	64	671718.....	66	672224.....	65
600234.....	49	610334.....	81	670504.....	66	671132.....	64	671719.....	66	672226.....	65
600241.....	49	610335.....	81	670505.....	66	671208.....	64	671721.....	66	672228.....	65
600242.....	49	610338.....	81	670506.....	66	671210.....	64	671808.....	66	672230.....	65
600323.....	50	610339.....	81	670507.....	66	671212.....	64	671809.....	66	672232.....	65
600326.....	50	610340.....	88	670508.....	66	671214.....	64	671810.....	66	672234.....	65
600331.....	51	610341.....	82	670509.....	66	671216.....	64	671811.....	66	672236.....	65
600341.....	51	610382.....	82	670510.....	66	671218.....	64	671812.....	66	672238.....	65
600402.....	52	610388.....	82	670511.....	66	671220.....	64	671813.....	66	672240.....	65
600406.....	52	610391.....	89	670512.....	66	671222.....	64	671814.....	66	672314.....	65
600503.....	53	610401.....	84	670513.....	66	671224.....	64	671815.....	66	672316.....	65
600505.....	53	610402.....	84	670602.....	66	671312.....	64	671816.....	66	672318.....	65
601102.....	54	610403.....	84	670604.....	66	671314.....	64	671817.....	66	672320.....	65
601107.....	54	610404.....	84	670606.....	66	671316.....	64	671818.....	66	672322.....	65
601111.....	63	610406.....	84	670607.....	66	671318.....	64	671819.....	66	672324.....	65
601113.....	54	610407.....	85	670608.....	66	671320.....	64	671901.....	340	672326.....	65
601118.....	54	610408.....	85	670609.....	66	671322.....	64	671902.....	48, 49, 72	672328.....	65
601201.....	60	610409.....	85	670610.....	66	671324.....	64	671904.....	74	672330.....	65
601202.....	60	610410.....	85	670611.....	66	671326.....	64	671905.....	48, 49, 74	672332.....	65
601216.....	62	610411.....	89	670612.....	66	671328.....	64	671907.....	48, 49, 74	672334.....	65
601219.....	55	610421.....	89	670702.....	66	671408.....	64	671908.....	74	672336.....	65
601220.....	55	610501.....	85	670704.....	66	671410.....	64	671909.....	73	672340.....	65
601224.....	56	610503.....	86	670705.....	66	671412.....	64	671910.....	48, 49, 71	672414.....	65
601226.....	56	610504.....	86	670706.....	66	671414.....	64	671911.....	73	672416.....	65
601227.....	55	610506.....	86	670707.....	66	671416.....	64	671913.....	71	672418.....	65
601229.....	55	610508.....	86	670708.....	66	671418.....	64	671914.....	71	672420.....	65
601231.....	63	610509.....	85	670709.....	66	671420.....	64	671917.....	71	672422.....	65
601232.....	63	610515.....	87	670710.....	66	671422.....	64	671921.....	42, 341	672424.....	65
601234.....	56	610901.....	91	670711.....	66	671424.....	64	671922.....	42, 341	672426.....	65
601236.....	56	610902.....	91	670712.....	66	671506.....	66	671923.....	40	672428.....	65
601312.....	58	610903.....	90	670713.....	66	671507.....	66	671926.....	38, 48, 49	672430.....	65
601313.....	57	610906.....	90	670802.....	66	671508.....	66	671928.....	39, 49, 341	672432.....	65
601314.....	58	670106.....	64	670804.....	66	671509.....	66	671930.....	73	672434.....	65

672436.....	65	672905.....	50, 51, 74	673630.....	67	677224.....	68	677851.....	70	682116.....	92
672440.....	65	672906.....	50, 51, 74	673632.....	67	677225.....	68	677852.....	70	682118.....	92
672508.....	67	672907.....	51, 73	673635.....	67	677226.....	68	677853.....	70	682120.....	92
672509.....	67	672908.....	50, 51, 71	673636.....	67	677227.....	68	677855.....	70	682122.....	92
672510.....	67	672909.....	73	673638.....	67	677228.....	68	677857.....	70	682124.....	92
672511.....	67	672911.....	71	673641.....	67	677230.....	68	677859.....	70	682126.....	92
672512.....	67	672912.....	71	673646.....	67	677232.....	68	677861.....	70	682128.....	92
672513.....	67	672913.....	71	673650.....	67	677253.....	69	677863.....	70	682130.....	92
672514.....	67	672914.....	74	673901.....	43, 52, 340	677254.....	69	677865.....	70	682132.....	92
672515.....	67	672918.....	72, 340	673903.....	43, 52, 74	677255.....	69	680915.....	91	682134.....	92
672516.....	67	672921.....	40, 341	673904.....	52, 74	677256.....	69	680918.....	91	682136.....	92
672517.....	67	672922.....	40, 341	673905.....	74	677257.....	69	681110.....	92	682138.....	92
672518.....	67	672923.....	40	673906.....	52, 73	677258.....	69	681112.....	92	682140.....	92
672519.....	67	672926.....	38, 50, 51	673907.....	71	677260.....	69	681114.....	92	682142.....	92
672520.....	67	672927.....	38	673909.....	72, 340	677274.....	69	681116.....	92	682144.....	92
672521.....	67	672928.....	39, 51, 341	673910.....	43, 52, 73	677275.....	69	681118.....	92	682146.....	92
672522.....	67	672929.....	38, 340	673911.....	43, 52, 72	677276.....	69	681120.....	92	682148.....	92
672523.....	67	672930.....	73	673912.....	43, 52, 71	677277.....	69	681122.....	92	682150.....	92
672524.....	67	672932.....	72	673913.....	44	677278.....	69	681124.....	92	682152.....	92
672527.....	67	672933.....	72	673914.....	44, 52	677279.....	69	681126.....	92	682154.....	92
672530.....	67	672947.....	75	673922.....	43, 52, 340	677280.....	69	681128.....	92	682156.....	92
672532.....	67	672948.....	75	673923.....	44, 52, 341	677316.....	68	681130.....	92	682158.....	92
672610.....	67	672949.....	75	673924.....	43, 341	677318.....	68	681132.....	92	682160.....	92
672611.....	67	672951.....	76	674223.....	65	677320.....	68	681210.....	92	682162.....	92
672612.....	67	672952.....	76	674224.....	65	677362.....	69	681212.....	92	682164.....	92
672613.....	67	672953.....	76	674226.....	65	677364.....	69	681214.....	92	682212.....	92
672614.....	67	673212.....	65	674227.....	65	677366.....	69	681216.....	92	682214.....	92
672615.....	67	673214.....	65	674228.....	65	677706.....	70	681218.....	92	682216.....	92
672616.....	67	673215.....	65	674229.....	65	677707.....	70	681220.....	92	682218.....	92
672617.....	67	673216.....	65	674230.....	65	677708.....	70	681222.....	92	682220.....	92
672618.....	67	673217.....	65	674232.....	65	677709.....	70	681224.....	92	682222.....	92
672619.....	67	673218.....	65	674234.....	65	677710.....	70	681226.....	92	682224.....	92
672620.....	67	673219.....	65	674235.....	65	677711.....	70	681228.....	92	682226.....	92
672621.....	67	673220.....	65	674236.....	65	677726.....	70	681230.....	92	682228.....	92
672622.....	67	673221.....	65	674238.....	65	677727.....	70	681232.....	92	682230.....	92
672624.....	67	673222.....	65	674240.....	65	677728.....	70	681508.....	93	682232.....	92
672710.....	67	673223.....	65	674242.....	65	677729.....	70	681509.....	93	682234.....	92
672712.....	67	673224.....	65	674244.....	65	677730.....	70	681510.....	93	682236.....	92
672713.....	67	673225.....	65	674247.....	65	677731.....	70	681511.....	93	682238.....	92
672714.....	67	673226.....	65	674248.....	65	677759.....	70	681512.....	93	682240.....	92
672715.....	67	673227.....	65	674250.....	65	677761.....	70	681513.....	93	682242.....	92
672716.....	67	673228.....	65	674901.....	43, 53, 340	677763.....	70	681514.....	93	682244.....	92
672717.....	67	673229.....	65	674903.....	53, 74	677764.....	70	681515.....	93	682246.....	92
672718.....	67	673230.....	65	674904.....	73	677766.....	70	681516.....	93	682248.....	92
672719.....	67	673232.....	65	674905.....	53, 74	677767.....	70	681517.....	93	682250.....	92
672720.....	67	673414.....	65	674906.....	44, 341	677783.....	70	681518.....	93	682252.....	92
672721.....	67	673415.....	65	674907.....	44	677784.....	70	681519.....	93	682254.....	92
672722.....	67	673416.....	65	674909.....	72, 340	677785.....	70	681607.....	93	682256.....	92
672723.....	67	673417.....	65	677021.....	68	677786.....	70	681608.....	93	682258.....	92
672724.....	67	673418.....	65	677022.....	68	677787.....	70	681609.....	93	682260.....	92
672727.....	67	673419.....	65	677023.....	68	677788.....	70	681610.....	93	682262.....	92
672810.....	67	673420.....	65	677071.....	69	677803.....	70	681611.....	93	682264.....	92
672811.....	67	673421.....	65	677072.....	69	677804.....	70	681612.....	93	682316.....	92
672812.....	67	673422.....	65	677073.....	69	677805.....	70	681613.....	93	682318.....	92
672813.....	67	673423.....	65	677127.....	68	677806.....	70	681614.....	93	682320.....	92
672814.....	67	673424.....	65	677128.....	68	677807.....	70	681615.....	93	682322.....	92
672815.....	67	673426.....	65	677128.....	68	677809.....	70	681616.....	93	682324.....	92
672816.....	67	673428.....	65	677130.....	68	677810.....	70	681617.....	93	682326.....	92
672817.....	67	673428.....	65	677132.....	68	677821.....	70	681618.....	93	682328.....	92
672817.....	67	673429.....	65	677177.....	69	677822.....	70	681619.....	93	682510.....	93
672818.....	67	673430.....	65	677178.....	69	677823.....	70	681911.....	91	682511.....	93
672819.....	67	673432.....	65	677179.....	69	677824.....	70	681915.....	91	682512.....	93
672820.....	67	673619.....	67	677180.....	69	677825.....	70	681917.....	91	682513.....	93
672821.....	67	673621.....	67	677204.....	68	677826.....	70	681918.....	91	682514.....	93
672822.....	67	673622.....	67	677205.....	68	677827.....	70	681952.....	90	682515.....	93
672824.....	67	673623.....	67	677206.....	68	677828.....	70	681953.....	90	682516.....	93
672901.....	340	673624.....	67	677207.....	68	677830.....	70	681954.....	90	682517.....	93
672902.....	72, 340	673626.....	67	677208.....	68	677832.....	70	682112.....	92	682518.....	93
672903.....	50, 72, 340	673627.....	67	677210.....	68	677845.....	70	682114.....	92	682519.....	93
672904.....	51, 74	673629.....	67	677212.....	68	677847.....	70				

682520.....	93	682966.....	83	683550.....	93	684198.....	92	687369.....	94	700321.....	103
682521.....	93	682967.....	83	683619.....	93	684199.....	92	687372.....	94	700322.....	103
682522.....	93	682968.....	83	683621.....	93	684228.....	92	687374.....	94	700331.....	104
682523.....	93	683124.....	92	683622.....	93	684230.....	92	687377.....	94	700336.....	104
682524.....	93	683126.....	92	683623.....	93	684232.....	92	687821.....	94	700361.....	102
682525.....	93	683128.....	92	683624.....	93	684234.....	92	687822.....	94	700371.....	103
682526.....	93	683130.....	92	683626.....	93	684236.....	92	687823.....	94	700372.....	103
682527.....	93	683132.....	92	683627.....	93	684238.....	92	687825.....	94	700381.....	104
682528.....	93	683134.....	92	683629.....	93	684240.....	92	687826.....	94	700386.....	104
682529.....	93	683136.....	92	683630.....	93	684242.....	92	687827.....	94	700392.....	106
682530.....	93	683138.....	92	683632.....	93	684244.....	92	687828.....	94	700408.....	106
682532.....	93	683140.....	92	683633.....	93	684246.....	92	687829.....	94	700414.....	106
682533.....	93	683142.....	92	683635.....	93	684248.....	92	687831.....	94	700453.....	100
682534.....	93	683144.....	92	683636.....	93	684250.....	92	687833.....	94	700455.....	100
682535.....	93	683146.....	92	683638.....	93	684252.....	92	688055.....	94	700456.....	100
682536.....	93	683148.....	92	683641.....	93	684254.....	92	688056.....	94	700458.....	100
682610.....	93	683150.....	92	683646.....	93	684256.....	92	688057.....	94	700459.....	100
682611.....	93	683152.....	92	683650.....	93	684258.....	92	688058.....	94	700461.....	100
682612.....	93	683154.....	92	683951.....	90	684260.....	92	688060.....	94	700462.....	100
682613.....	93	683156.....	92	683952.....	90	684262.....	92	688062.....	94	700464.....	100
682614.....	93	683158.....	92	683953.....	90	684264.....	92	688064.....	94	700501.....	97
682615.....	93	683160.....	92	683954.....	90	684266.....	92	688066.....	94	700502.....	97
682616.....	93	683162.....	92	683955.....	91	684268.....	92	688110.....	94	700503.....	97
682617.....	93	683164.....	92	684124.....	92	684270.....	92	688111.....	94	700504.....	97
682618.....	93	683166.....	92	684126.....	92	684272.....	92	688112.....	94	700505.....	97
682619.....	93	683168.....	92	684128.....	92	684274.....	92	688114.....	94	700506.....	97
682620.....	93	683170.....	92	684130.....	92	684276.....	92	688116.....	94	700507.....	97
682621.....	93	683172.....	92	684132.....	92	684278.....	92	688118.....	94	700508.....	97
682622.....	93	683174.....	92	684134.....	92	684280.....	92	688120.....	94	700509.....	97
682623.....	93	683176.....	92	684136.....	92	684282.....	92	688122.....	94	700510.....	97
682624.....	93	683178.....	92	684138.....	92	684284.....	92	688124.....	94	700511.....	97
682625.....	93	683180.....	92	684140.....	92	684288.....	92	690104.....	39	700512.....	97
682626.....	93	683224.....	92	684142.....	92	684614.....	87	690105.....	43, 52	700513.....	97
682627.....	93	683226.....	92	684144.....	92	684616.....	87	690106.....	38	700514.....	97
682628.....	93	683228.....	92	684146.....	92	684619.....	87	690107.....	42	700515.....	97
682629.....	93	683230.....	92	684148.....	92	684622.....	87	690111.....	71	700517.....	97
682630.....	93	683232.....	92	684150.....	92	684921.....	87	690115.....	71	700518.....	97
682632.....	93	683234.....	92	684152.....	92	684922.....	87	690120.....	74	700519.....	97
682633.....	93	683236.....	92	684154.....	92	684943.....	87	690121.....	74	700520.....	97
682634.....	93	683238.....	92	684156.....	92	684944.....	87	690122.....	76	700521.....	97
682635.....	93	683240.....	92	684158.....	92	684946.....	87	690123.....	76	700523.....	97
682636.....	93	683242.....	92	684160.....	92	684951.....	90	690124.....	75	700524.....	97
682713.....	93	683244.....	92	684162.....	92	684952.....	90	690125.....	75	700525.....	97
682714.....	93	683246.....	92	684164.....	92	684955.....	91	690130.....	73	700526.....	97
682715.....	93	683248.....	92	684165.....	92	684966.....	87	699701.....	339	700527.....	97
682716.....	93	683250.....	92	684166.....	92	684971.....	87	699702.....	337, 338	700529.....	97
682717.....	93	683252.....	92	684167.....	92	684975.....	87	699703.....	335, 336	700531.....	97
682718.....	93	683254.....	92	684168.....	92	687211.....	94	699704.....	332, 333, 334	700533.....	97
682719.....	93	683256.....	92	684169.....	92	687212.....	94	700110.....	96	700535.....	97
682721.....	93	683258.....	92	684170.....	92	687213.....	94	700115.....	96	700537.....	97
682722.....	93	683260.....	92	684171.....	92	687214.....	94	700121.....	96	700552.....	97
682867.....	82	683262.....	92	684172.....	92	687215.....	94	700125.....	97	700553.....	97
682869.....	82	683264.....	92	684173.....	92	687216.....	94	700128.....	97	700554.....	97
682871.....	82	683519.....	93	684174.....	92	687217.....	94	700132.....	98	700555.....	97
682876.....	82	683521.....	93	684175.....	92	687219.....	94	700134.....	98	700556.....	97
682878.....	82	683522.....	93	684176.....	92	687261.....	94	700136.....	98	700557.....	97
682911.....	91	683523.....	93	684177.....	92	687262.....	94	700137.....	101	700558.....	97
682915.....	91	683524.....	93	684178.....	92	687263.....	94	700164.....	102	700559.....	97
682917.....	91	683526.....	93	684179.....	92	687265.....	94	700167.....	96	700560.....	97
682918.....	91	683527.....	93	684180.....	92	687267.....	94	700173.....	96	700561.....	97
682938.....	90	683529.....	93	684182.....	92	687269.....	94	700177.....	96	700562.....	97
682939.....	90	683530.....	93	684184.....	92	687272.....	94	700182.....	98	700563.....	97
682952.....	90	683532.....	93	684186.....	92	687274.....	94	700185.....	98	700564.....	97
682953.....	90	683533.....	93	684188.....	92	687320.....	94	700186.....	98	700565.....	97
682954.....	90	683535.....	93	684190.....	92	687324.....	94	700191.....	101	700566.....	97
682955.....	90	683536.....	93	684192.....	92	687328.....	94	700201.....	96	700567.....	97
682961.....	83	683538.....	93	684194.....	92	687332.....	94	700212.....	100	700568.....	97
682964.....	83	683541.....	93	684196.....	92	687340.....	94	700308.....	102	700569.....	97
682965.....	83	683546.....	93	684197.....	92	687367.....	94	700312.....	102	700571.....	97

700572.....	97	700860.....	99	701259.....	105	711134.....	109	718952.....	124	720566.....	134
700575.....	97	700862.....	99	701260.....	105	711135.....	109	718956.....	124	720574.....	128
700577.....	97	700863.....	99	701261.....	105	711136.....	109	718961.....	124	720580.....	343
700621.....	99	700864.....	99	701262.....	105	711137.....	109	718962.....	124	720581.....	343
700622.....	99	701101.....	105	701263.....	105	711139.....	109	718991.....	124	720582.....	343
700623.....	99	701102.....	105	701264.....	105	711146.....	111	719001.....	107	720583.....	343
700624.....	99	701103.....	105	701301.....	105	711152.....	109	719002.....	107	720584.....	343
700625.....	99	701104.....	105	701302.....	105	711153.....	109	719003.....	107	720590.....	137
700626.....	99	701105.....	105	701303.....	105	711154.....	109	719004.....	107	720592.....	343
700627.....	99	701107.....	105	701304.....	105	711155.....	109	719006.....	107	720593.....	343
700628.....	99	701108.....	105	701305.....	105	711156.....	109	719007.....	107	720594.....	343
700629.....	99	701109.....	105	701306.....	105	711157.....	109	719008.....	107	720595.....	343
700630.....	99	701110.....	105	701307.....	105	711159.....	109	719009.....	107	720596.....	343
700631.....	99	701111.....	105	701308.....	105	711191.....	108	719069.....	122, 342	720597.....	343
700632.....	99	701112.....	105	701309.....	105	715201.....	110	719071.....	126	720598.....	343
700633.....	99	701113.....	105	701310.....	105	715202.....	110	719072.....	126	720599.....	343
700634.....	99	701121.....	105	701311.....	105	715203.....	110	719074.....	126	720605.....	135
700635.....	99	701122.....	105	701353.....	105	715204.....	110	719075.....	126	720606.....	135
700637.....	99	701123.....	105	701354.....	105	715205.....	110	719111.....	107	720607.....	135
700672.....	99	701124.....	105	701355.....	105	715206.....	110	719121.....	107	720612.....	135
700673.....	99	701125.....	105	701356.....	105	715207.....	110	719151.....	111	720613.....	135
700674.....	99	701126.....	105	701357.....	105	715208.....	110	719153.....	111	720616.....	135
700675.....	99	701127.....	105	701358.....	105	715209.....	110	719154.....	111	720621.....	135
700676.....	99	701128.....	105	701359.....	105	715210.....	110	719155.....	111	720622.....	135
700677.....	99	701129.....	105	701360.....	105	715211.....	110	719156.....	111	720623.....	135
700678.....	99	701130.....	105	701362.....	105	715212.....	110	719157.....	111	720626.....	135
700679.....	99	701131.....	105	701363.....	105	715213.....	110	719159.....	111	720627.....	135
700680.....	99	701132.....	105	701364.....	105	715214.....	110	719162.....	111	720628.....	135
700681.....	99	701133.....	105	710122.....	175	715215.....	110	719163.....	111	720632.....	135
700682.....	99	701153.....	105	710123.....	175	715216.....	110	719165.....	111	720633.....	135
700683.....	99	701154.....	105	710124.....	175	715217.....	110	720354.....	129	720634.....	135
700684.....	99	701155.....	105	710125.....	175	715218.....	110	720356.....	129	720635.....	135
700685.....	99	701156.....	105	710127.....	175	715219.....	110	720360.....	129	720641.....	135
700686.....	99	701157.....	105	710130.....	175	715220.....	110	720362.....	129	720642.....	135
700687.....	99	701158.....	105	710136.....	175	715221.....	110	720363.....	129	720644.....	135
700688.....	99	701159.....	105	710142.....	174	715222.....	110	720366.....	129	720646.....	135
700689.....	99	701160.....	105	710143.....	174	715223.....	110	720371.....	129	720648.....	135
700703.....	101	701161.....	105	710144.....	174	715224.....	110	720372.....	129	720649.....	135
700704.....	101	701162.....	105	710145.....	174	715225.....	110	720373.....	129	720702.....	144
700705.....	101	701163.....	105	710147.....	174	715226.....	110	720382.....	129	720812.....	133
700706.....	101	701164.....	105	710150.....	174	715227.....	110	720392.....	129	720813.....	133
700707.....	101	701173.....	105	710156.....	174	715228.....	110	720404.....	131	720814.....	133
700708.....	101	701174.....	105	710159.....	174	715229.....	110	720406.....	131	720815.....	133
700709.....	101	701175.....	105	710225.....	175	715230.....	110	720421.....	131	720817.....	133
700755.....	101	701176.....	105	710227.....	175	715231.....	110	720422.....	131	720818.....	133
700757.....	101	701177.....	105	710230.....	175, 342	715232.....	110	720423.....	131	720821.....	133
700758.....	101	701178.....	105	710236.....	175	715233.....	110	720431.....	131	720823.....	133
700760.....	101	701179.....	105	710239.....	175	715234.....	110	720432.....	131	720824.....	133
700762.....	101	701180.....	105	710245.....	174	715235.....	110	720433.....	131	720827.....	133
700763.....	101	701181.....	105	710247.....	174	718861.....	342	720444.....	131	720832.....	133
700764.....	101	701182.....	105	710250.....	174	718902.....	122, 342	720446.....	131	720834.....	133
700801.....	99	701183.....	105	710256.....	174	718903.....	342	720505.....	128	720835.....	133
700802.....	99	701184.....	105	710902.....	112	718906.....	122, 342	720507.....	128	720837.....	133
700803.....	99	701196.....	41, 106	710903.....	112	718908.....	122, 342	720508.....	130	720841.....	133
700804.....	99	701201.....	105	710904.....	112	718909.....	342	720523.....	132	720842.....	133
700805.....	99	701202.....	105	710912.....	112	718911.....	122, 342	720524.....	132	720843.....	133
700806.....	99	701203.....	105	710913.....	112	718912.....	122, 342	720527.....	132	720844.....	133
700807.....	99	701204.....	105	710914.....	112	718913.....	342	720531.....	136	720845.....	133
700808.....	99	701205.....	105	711102.....	108	718914.....	342	720533.....	136	720846.....	133
700809.....	99	701206.....	105	711111.....	108	718916.....	342	720534.....	136	720848.....	133
700810.....	99	701207.....	105	711112.....	108	718917.....	342	720542.....	144	720911.....	129
700811.....	99	701208.....	105	711113.....	108	718918.....	122, 342	720546.....	144	720917.....	129
700853.....	99	701209.....	105	711114.....	108	718922.....	122, 342	720551.....	138	720922.....	129
700854.....	99	701253.....	105	711115.....	108	718933.....	122, 342	720552.....	139	720925.....	129
700855.....	99	701254.....	105	711116.....	108	718935.....	342	720556.....	139	720929.....	129
700856.....	99	701255.....	105	711117.....	108	718936.....	123, 342	720559.....	138	720932.....	129
700857.....	99	701256.....	105	711118.....	108	718941.....	125	720560.....	134	720956.....	128
700858.....	99	701257.....	105	711132.....	109	718943.....	125	720562.....	134	721101.....	142
700859.....	99	701258.....	105	711133.....	109	718946.....	125	720564.....	134	721102.....	142

721105.....	143	729101.....	141	730335.....	147	731192.....	203	740179.....	187	741121.....	189
721111.....	143	729104.....	141	730336.....	147	731204.....	204	740191.....	185	741123.....	189
721112.....	143	729109.....	141	730338.....	146	731205.....	204	740307.....	182	741141.....	189
721113.....	143	729112.....	140	730341.....	150	731214.....	204	740321.....	183	741142.....	189
721114.....	143	729114.....	140	730352.....	149	731215.....	204	740331.....	183	760002.....	168
721115.....	143	729115.....	141	730353.....	149	731238.....	203	740347.....	182	760202.....	169
721116.....	143	729117.....	141	730401.....	151	731244.....	203	740348.....	182	760211.....	169, 170
721117.....	143	729119.....	140	730402.....	151	731256.....	203	740381.....	183	760213.....	168, 169, 170
721141.....	142	729121.....	140	730403.....	151	731278.....	203	740386.....	183	760214.....	168, 169, 170
721142.....	142	729122.....	141	730414.....	152	731284.....	203	740403.....	189	760221.....	169, 170
721143.....	142	729124.....	141	730415.....	152	731296.....	203	740407.....	189	760224.....	168, 169, 170
721144.....	142	729163.....	140	730418.....	152	731453.....	204	740522.....	188	760226.....	168, 169, 170
721145.....	142	729166.....	140	730423.....	151	735102.....	152	740523.....	188	760228.....	169, 170
721146.....	142	729169.....	141	730425.....	151	735210.....	164	740524.....	188	760234.....	169, 170
721147.....	142	729173.....	140	730428.....	151	735252.....	156	740525.....	188	760236.....	168, 169, 170
721151.....	142	729176.....	141	730433.....	152	735253.....	156	740526.....	188	760262.....	169, 171
721152.....	142	729180.....	140	730435.....	152	735254.....	156	740528.....	188	760263.....	169, 171
721153.....	142	729183.....	141	730441.....	151	735255.....	156	740532.....	188	760265.....	169, 171
721154.....	142	729187.....	140	730442.....	151	735256.....	156	740533.....	188	760266.....	169, 171
721155.....	142	729190.....	141	730443.....	151	735262.....	157	740534.....	188	760267.....	169, 171
721156.....	142	729194.....	140	730445.....	151	735264.....	157	740535.....	188	760312.....	168, 171
721157.....	142	729197.....	141	730452.....	146	735275.....	156	740536.....	188	760322.....	168, 171
721361.....	129	729201.....	140	730453.....	147	735301.....	164	740538.....	188	760332.....	168, 171
721362.....	129	729204.....	141	730454.....	146	735302.....	164	740560.....	187	760341.....	168, 171
721363.....	129	729208.....	140	730455.....	147	735303.....	164	740565.....	187	760352.....	168, 171
721372.....	129	729211.....	141	730456.....	147	735305.....	163	740569.....	187	770132.....	238, 291
729009.....	140	729303.....	140	730457.....	146	735311.....	164	740580.....	187	770133.....	238, 291
729011.....	140	729306.....	141	730458.....	147	735322.....	164	740581.....	187	770134.....	238, 291
729013.....	141	729317.....	140	730459.....	147	735323.....	164	740582.....	187	770135.....	238, 291
729015.....	141	729320.....	141	730462.....	147	735391.....	164	740583.....	187	770152.....	239, 292
729018.....	141	729324.....	140	730463.....	147	735403.....	204	740584.....	187	770302.....	169, 239, 291
729020.....	141	729327.....	141	730464.....	146	739102.....	176, 178	740585.....	187	770312.....	239, 291
729022.....	141	729331.....	140	730466.....	146	739104.....	176, 178	740586.....	187	770313.....	239, 291
729025.....	140	729334.....	141	730467.....	147	739105.....	178	740587.....	187	770314.....	239, 291
729027.....	140	729338.....	140	730473.....	152	739107.....	177, 178	740588.....	187	774408.....	119
729028.....	140	729341.....	141	730483.....	151	739108.....	177, 178	740589.....	187	774409.....	119
729029.....	141	729366.....	140	730485.....	151	739109.....	176, 178	740593.....	187	774410.....	119
729031.....	141	729369.....	141	730488.....	151	739111.....	177, 178	740596.....	187	774411.....	119
729032.....	141	729373.....	140	730496.....	148	739116.....	178	740598.....	187	774412.....	119
729034.....	141	729376.....	141	730554.....	148	739122.....	178	740901.....	189	774413.....	119
729036.....	141	729380.....	140	730555.....	148	739125.....	178	740912.....	190	774414.....	119
729039.....	141	729383.....	141	730556.....	148	739132.....	179	740913.....	190	774415.....	119
729040.....	141	729394.....	140	730557.....	148	739133.....	179	740914.....	190	774417.....	119
729042.....	140	729397.....	141	730558.....	148	739142.....	177	740915.....	190	774419.....	119
729044.....	140	729461.....	141	730559.....	148	739181.....	180	740926.....	190	774457.....	120
729046.....	141	729462.....	141	730701.....	149	739191.....	176, 178	740927.....	190	774458.....	120
729048.....	141	729463.....	141	730702.....	149	739192.....	176, 178	740928.....	190	774459.....	120
729051.....	141	729471.....	141	730703.....	149	739193.....	176, 178	740932.....	191	774460.....	120
729056.....	141	729472.....	141	730704.....	149	739194.....	176, 178	740933.....	191	774462.....	120
729061.....	140	729473.....	141	730711.....	158	739195.....	178	740934.....	191	774464.....	120
729063.....	140	729475.....	141	730724.....	158	739197.....	178	740952.....	188	774466.....	120
729065.....	141	729483.....	140	730725.....	158	739198.....	178	740953.....	188	774468.....	120
729067.....	141	729484.....	140	730731.....	158	740103.....	184	740971.....	190	774491.....	120
729070.....	141	730206.....	155	730736.....	158	740105.....	184	740972.....	190	774492.....	120
729072.....	141	730207.....	155	730738.....	158	740107.....	184	740974.....	190	774493.....	120
729075.....	141	730216.....	155	731108.....	203	740151.....	184	740975.....	190	774494.....	120
729078.....	140	730217.....	155	731112.....	203	740153.....	184	740977.....	190	774496.....	120
729080.....	140	730218.....	155	731114.....	203	740155.....	184	740978.....	190	774497.....	120
729081.....	140	730221.....	152	731118.....	203	740157.....	184	740979.....	190	774498.....	120
729082.....	141	730222.....	154	731124.....	203	740158.....	184	740983.....	185	774507.....	118
729084.....	141	730227.....	155	731130.....	203	740161.....	184	740984.....	185	774508.....	118
729085.....	141	730232.....	152	731136.....	203	740163.....	184	740985.....	185	774510.....	118
729087.....	141	730236.....	154	731142.....	203	740164.....	184	740988.....	185	774512.....	118
729089.....	141	730241.....	154	731162.....	203	740165.....	184	740995.....	191	774513.....	118
729092.....	141	730246.....	154	731164.....	203	740166.....	184	740996.....	191	774515.....	118
729093.....	141	730251.....	155	731168.....	203	740174.....	185, 187	740997.....	191	774517.....	118
729095.....	140	730305.....	153	731174.....	203	740175.....	185, 187	740998.....	191	774519.....	118
729097.....	140	730311.....	150	731180.....	203	740176.....	185, 187	740999.....	191	774557.....	118
729099.....	141	730321.....	150	731186.....	203	740178.....	187	741107.....	189	774558.....	118

774559.....	118	774917.....	119	775192.....	114	779171.....	208	842001.....	22	849482.....	210
774560.....	118	774919.....	119	775306.....	211	779201.....	200	842002.....	22	849491.....	210
774562.....	118	774956.....	120	775307.....	211	779203.....	200	842006.....	22	849492.....	210
774564.....	118	774957.....	120	775308.....	211	779205.....	200	842011.....	23	849493.....	210
774566.....	118	774958.....	120	775400.....	194	779211.....	201	842016.....	23	849494.....	210
774568.....	118	774959.....	120	775401.....	194	779212.....	201	842091.....	25	849495.....	210
774607.....	119	774960.....	120	775402.....	194	779213.....	201	842092.....	25	849802.....	666, 675
774608.....	119	774962.....	120	775403.....	194	779214.....	201	842096.....	24	849811.....	666, 675
774610.....	119	774964.....	120	775404.....	194	779215.....	201	842097.....	24	849812.....	666, 675
774612.....	119	774966.....	120	775405.....	194	779216.....	201	842104.....	12	849816.....	667, 675
774613.....	119	774968.....	120	775406.....	194	779218.....	201	842105.....	12	849817.....	667, 675
774614.....	119	775005.....	119	775410.....	195	779220.....	328	842124.....	12	849818.....	667, 675
774615.....	119	775006.....	119	775411.....	195	779221.....	328	842134.....	12	849819.....	667, 675
774617.....	119	775007.....	119	775412.....	195	779222.....	328	842142.....	12	849821.....	668, 675
774619.....	119	775008.....	119	775413.....	195	779223.....	328	842143.....	12	849831.....	669, 675
774657.....	120	775009.....	119	775420.....	195	779224.....	328	842144.....	12	849833.....	669, 675
774658.....	120	775010.....	119	775421.....	195	779231.....	201	842152.....	12	849834.....	671, 675
774659.....	120	775011.....	119	775422.....	195	779232.....	201	842153.....	12	849835.....	669, 675
774660.....	120	775012.....	119	775423.....	195	779233.....	201	842154.....	12	849837.....	669, 675
774662.....	120	775013.....	119	775424.....	195	779234.....	201	842202.....	20	849839.....	670, 675
774663.....	120	775014.....	119	775425.....	195	779240.....	328	842204.....	20	849851.....	671, 675
774664.....	120	775015.....	119	775430.....	196	779241.....	328	842252.....	20	849852.....	671, 675
774666.....	120	775017.....	119	775431.....	196	779242.....	328	842254.....	20	849853.....	671, 675
774668.....	120	775019.....	119	775432.....	196	779243.....	328	842256.....	21	849861.....	674
774691.....	120	775021.....	119	775433.....	196	779244.....	328	842281.....	28	849862.....	674
774692.....	120	775022.....	119	775434.....	196	779252.....	200	842286.....	28	849864.....	674
774693.....	120	775023.....	119	775435.....	196	779253.....	200	842480.....	21	849866.....	674
774694.....	120	775025.....	119	775436.....	196	779255.....	200	842481.....	21	849867.....	674
774695.....	120	775054.....	120	775437.....	196	779256.....	200	842503.....	13	849869.....	674
774696.....	120	775056.....	120	775440.....	195	779258.....	201	842513.....	14	849871.....	672, 675
774697.....	120	775057.....	120	775441.....	195	779266.....	330	842523.....	14	849872.....	672, 675
774698.....	120	775058.....	120	775442.....	195	779267.....	330	842542.....	15	849875.....	672, 675
774699.....	120	775059.....	120	775443.....	195	779268.....	330	842543.....	15	849876.....	672, 675
774756.....	120	775060.....	120	775452.....	194	779271.....	330	842553.....	13	849877.....	672, 675
774757.....	120	775061.....	120	775453.....	194	779274.....	330	842563.....	14	849879.....	673, 675
774758.....	120	775063.....	120	775454.....	194	779275.....	330	842573.....	14	849881.....	674
774759.....	120	775064.....	120	775455.....	194	779276.....	330	842602.....	17	849882.....	674
774760.....	120	775065.....	120	775456.....	194	779277.....	330	842604.....	17	849884.....	674
774761.....	120	775067.....	120	775457.....	194	779279.....	330	842613.....	19	849886.....	674
774762.....	120	775069.....	120	775461.....	196	779901.....	67	842614.....	19	849887.....	674
774763.....	120	775073.....	120	775462.....	196	840401.....	161	842623.....	19	849889.....	674
774764.....	120	775075.....	120	775507.....	193	840411.....	161, 162	842652.....	16	849893.....	674
774765.....	120	775077.....	120	775508.....	193	840421.....	162	842653.....	16	849894.....	674
774766.....	120	775080.....	120	775509.....	192	840422.....	162	842654.....	16	849896.....	669
774767.....	120	775082.....	120	775511.....	193	840431.....	160, 162	842663.....	18	859042.....	165
774768.....	120	775103.....	116, 120	775513.....	193	840432.....	160, 162	842673.....	18	859043.....	165
774806.....	119	775104.....	117, 119	775526.....	192	840433.....	160, 162	842704.....	26	859044.....	165
774807.....	119	775105.....	116, 120	775531.....	192	840441.....	161, 162	842712.....	27	859211.....	202, 329
774808.....	119	775106.....	117, 120	775592.....	196	840442.....	161, 162	842722.....	27	859212.....	202, 329
774809.....	119	775108.....	117, 120	775910.....	205	840481.....	162	842754.....	26	859213.....	202, 329
774810.....	119	775109.....	116, 119	775921.....	205	840482.....	162	842762.....	27	859214.....	202, 329
774811.....	119	775112.....	114	775928.....	205	840486.....	162	842772.....	27	859215.....	202, 329
774812.....	119	775114.....	114	775929.....	205	840488.....	162	842902.....	32	859301.....	327
774813.....	119	775122.....	118	775936.....	205	840491.....	162	842907.....	32	859302.....	327
774814.....	119	775127.....	118	776001.....	207	840494.....	162	842909.....	32	859304.....	327
774815.....	119	775144.....	114	776002.....	207	840497.....	162	842911.....	30	859305.....	327
774817.....	119	775146.....	114	776004.....	207	841011.....	34	842916.....	30	859306.....	327
774819.....	119	775153.....	114	776006.....	208	841021.....	34	842921.....	31	859307.....	327
774905.....	119	775156.....	114	776021.....	207	841031.....	34	842926.....	31	859308.....	327
774906.....	119	775162.....	115	776022.....	207	841051.....	35	843002.....	33	859309.....	327
774907.....	119	775164.....	115, 119, 120	776055.....	206	841056.....	35	843003.....	33	859310.....	327
774908.....	119	775165.....	117, 119, 120	776060.....	206	841061.....	35	843012.....	33	859311.....	327
774909.....	119	775173.....	115, 119	776061.....	206	841112.....	36	849403.....	209, 210	859312.....	327
774910.....	119	775175.....	116, 119	776065.....	206	841113.....	36	849407.....	210	859313.....	327
774911.....	119	775176.....	116, 119	776070.....	206	841122.....	36	849409.....	210	859314.....	327
774912.....	119	775184.....	115, 120	779112.....	202	841123.....	36	849411.....	209, 210	859315.....	327
774913.....	119	775185.....	116, 120	779113.....	202	841132.....	36	849412.....	209, 210	859316.....	327
774914.....	119	775186.....	116, 120	779161.....	208	841133.....	36	849416.....	210	859317.....	327
774915.....	119	775191.....	114	779162.....	208	841151.....	34	849481.....	210	859341.....	326

859342.....	326	890625.....	908	905754.....	505	H1099.....	295	H1441.....	299	H1845EE.....	279
859343.....	326	890633.....	905	905755.....	505	H1103.....	262	H1442.....	299	H1845ET.....	279
859344.....	326	890670.....	909	905756.....	505	H1105.....	306	H1456.....	297	H1845F.....	278, 279
859345.....	326	890679.....	900	905761.....	500	H1107.....	262	H1458.....	297	H1845FF.....	278, 279
890145.....	906	890927.....	900	905781.....	491, 492	H1116.....	309	H1458-10.....	297	H1845G.....	278
890157.....	910	890928.....	904	905782.....	491	H1120.....	180, 264	H1458-11.....	297	H1845GG.....	278
890168.....	907	891147.....	904	905802.....	514	H1120A.....	180, 264	H1458-12.....	297	H1845H.....	278, 279
890174.....	903	891148.....	904	905842.....	514	H1120B.....	180, 264	H1458-13.....	297	H1845HH.....	279
890175.....	903	900202.....	340	905852.....	509	H1120C.....	180, 264	H1458-14.....	297	H1845J.....	278
890177.....	903	900203.....	340	905861.....	509, 511	H1120D.....	180, 264	H1458-15.....	297	H1845K.....	278, 279
890181.....	902	900204.....	340	905862.....	509, 511	H1120E.....	180, 264	H1458-16.....	297	H1845KK.....	278
890182.....	902	900205.....	340	7739181.....	264	H1120F.....	180, 264	H1458-17.....	297	H1845L.....	278, 279
890183.....	906	900210.....	340	038703K.....	911	H1120G.....	180, 264	H1486.....	269	H1845M.....	278, 279
890184.....	902	900215.....	340	038710K.....	911	H1120H.....	180, 264	H1493.....	302	H1845N.....	278
890187.....	902	900218.....	340	120AP07A.....	647	H1120J.....	180, 264	H1502.....	179, 265	H1845P.....	278, 279
890195.....	902	900219.....	340	12NP04.....	647	H1120K.....	180, 264	H1502A.....	179, 265	H1845Q.....	278
890402.....	906	900225.....	341	135P9.....	647	H1121.....	180, 264	H1502B.....	179, 265	H1845R.....	278, 279
890404.....	906	900226.....	341	150P23.....	647	H1121A.....	180, 264	H1502C.....	179, 265	H1845S.....	279
890407.....	903	900227.....	341	500408A01.....	377	H1121B.....	180, 264	H1502D.....	179, 265	H1845V.....	278, 279
890411.....	907	900228.....	341	500418A01.....	377	H1121C.....	180, 264	H1502E.....	179, 265	H1845W.....	278, 279
890417.....	906	900230.....	340	500428A01.....	377	H1121D.....	180, 264	H1502F.....	179, 265	H1845X.....	279
890424.....	905	900235.....	340	501571A02.....	356	H1121E.....	180, 264	H1502G.....	179, 265	H1845Y.....	278, 279
890426.....	903	900236.....	340	501576A02.....	356	H1121F.....	180, 264	H1502H.....	179, 265	H1845Z.....	279
890427.....	903	900239.....	340	501805A02.....	354	H1121G.....	180, 264	H1503.....	307	H1858.....	297
890428.....	902	900240.....	341	501808A02.....	354	H1121H.....	264	H1560.....	273	H1859.....	294
890429.....	902	900241.....	341	502412A05.....	396	H1122.....	306	H1670.....	281	H1863.....	294
890430.....	902	900251.....	341	502413A05.....	396	H1137.....	294	H1670A.....	281	H1864.....	266
890431.....	910	900252.....	341	502414A05.....	396	H1141.....	307	H1670B.....	281	H1864C.....	266
890432.....	910	900253.....	340	502416A05.....	396	H1142.....	309	H1670C.....	281	H1866.....	282
890435.....	905	900257.....	341	502422A05.....	396	H1143.....	310	H1670D.....	281	H1901.....	290
890440.....	907	900258.....	341	502423A05.....	396	H1144.....	310	H1670E.....	281	H1902.....	272
890441.....	907	900259.....	340	502424A05.....	396	H1145.....	310	H1670F.....	281	H1903.....	290
890442.....	903	900289.....	72	502426A05.....	396	H1147.....	309	H1670G.....	281	H1905.....	289
890444.....	902	905126.....	475	503213A01.....	386	H1151.....	309	H1670H.....	281	H1907.....	272
890446.....	903	905146.....	509	503215A01.....	386	H1175.....	283	H1670I.....	281	H1921.....	290
890449.....	908	905301.....	517	503217A01.....	386	H1176.....	283	H1670J.....	281	H1926.....	270, 271
890450.....	906	905302.....	517	503223A01.....	386	H1179.....	176	H1670K.....	281	H2000.....	286
890452.....	909	905303.....	517	503225A01.....	386	H1183.....	282	H1670L.....	281	H2000A.....	286
890455.....	902	905304.....	517	503227A01.....	386	H1185.....	282	H1670M.....	281	H2000AA.....	286
890456.....	902	905305.....	517	503513A01.....	400	H1229.....	306	H1677.....	300	H2000AB.....	286
890457.....	902	905306.....	517	503515A01.....	400	H1230.....	306	H1728.....	280	H2000B.....	286
890460.....	908	905307.....	517	503517A01.....	400	H1244.....	306	H1730.....	277	H2000B90.....	286
890461.....	904	905310.....	519	503523A01.....	400	H1262.....	282	H1730B.....	277	H2000BK.....	286
890462.....	904	905313.....	519	503525A01.....	400	H1273.....	298	H1730C.....	277	H2000C.....	286
890463.....	904	905317.....	519	503527A01.....	400	H1273A.....	298	H1730D.....	277	H2000C90.....	286
890464.....	904	905318.....	491	671926A.....	340	H1273B.....	298	H1730E.....	277	H2000D.....	286
890466.....	904	905319.....	492	671940B.....	341	H1273C.....	298	H1730F.....	277	H2000DX.....	286
890467.....	906	905402.....	524	671942A.....	340	H1273D.....	298	H1730H.....	277	H2000E.....	286
890471.....	903	905403.....	524	671943A.....	340	H1273E.....	298	H1731.....	277	H2000F.....	286
890472.....	903	905404.....	524	672926B.....	340	H1278.....	263	H1734X.....	280	H2000G.....	286
890473.....	905	905405.....	524	672927B.....	340	H1279.....	300	H1841.....	266	H2000H.....	286
890475.....	908	905412.....	524	E06961.....	572	H1295.....	296	H1841A.....	266	H2000HA.....	286
890476.....	905	905413.....	524	E06962.....	572	H1301.....	310	H1843.....	266	H2000HH.....	286
890477.....	907	905432.....	524	H.....		H1302.....	310	H1843A.....	266	H2000J.....	286
890481.....	900	905433.....	524	H1007.....	300	H1304.....	302	H1843E.....	266	H2000K.....	286
890482.....	900	905451.....	497	H1014.....	296	H1345.....	299	H1843F.....	266	H2000KA.....	286
890483.....	901	905452.....	497	H1017.....	283	H1346.....	299	H1844.....	266	H2000KB.....	286
890485.....	901	905453.....	497	H1039.....	292	H1361.....	302	H1844B.....	266	H2000KC.....	286
890499.....	904	905461.....	496	H1060.....	296	H1363.....	293	H1844E.....	266	H2000L.....	286
890502.....	907	905471.....	496	H1061.....	296	H1363C.....	293	H1845.....	278, 279	H2000M.....	286
890503.....	907	905491.....	500	H1062.....	296	H1364.....	293	H1845-2.....	278	H2000M11.....	286
890504.....	907	905492.....	500	H1063.....	296	H1365.....	298	H1845-4.....	278	H2000M15.....	286
890505.....	907	905493.....	500	H1066.....	304	H1365A.....	298	H1845-5.....	279	H2000M16.....	286
890506.....	907	905494.....	500	H1080.....	306	H1365B.....	298	H1845A.....	278	H2000N.....	286
890516.....	906	905742.....	512, 513	H1084.....	273	H1365C.....	298	H1845B.....	278	H2000NN.....	286
890517.....	906	905743.....	513	H1085.....	262	H1365D.....	298	H1845C.....	278	H2000P.....	286
890518.....	906	905751.....	505	H1088.....	273	H1365E.....	298	H1845D.....	278, 279	H2000Q.....	286
890519.....	906	905752.....	505	H1090.....	302	H1386.....	306	H1845DD.....	278	H2000R.....	286
890520.....	906	905753.....	505	H1096.....	262	H1440.....	299	H1845E.....	278, 279	H2000RA.....	286

H2000RK	286	H3148A	283	H3379	295	H3573-40	299	HTA1136A	314	V1021580 (134N)	722
H2000S	286	H3148B	283	H3380	295	H3573-41	299	HTA1136B	314	V1021840 (139PK)	724
H2000T	286	H3148C	283	H3381	295	H3573-42	299	HTA1136C	314	V1021850 (136)	724
H2000U	286	H3148D	283	H3382	295	H3573-43	299	HTA1144	312	V1021860 (139)	724
H2000UA	286	H3148E	283	H3383	295	H3573-44	299	HTA1144A	314	V1021870 (139BK)	724
H2000UB	286	H3148F	283	H3384	295	H3573-45	299	HTA1144B	314	V1021950 (6938)	724
H2000UC	286	H3149	268	H3391	300	H3573-46	299	HTA1144C	314	V1021960 (6939)	724
H2000UPA	286	H3150	268	H3400	136, 298	H3573-47	299	HTA1146A	314	V1022150 (156)	723
H2000V	286	H3151	268	H3405	269	H3573-48	299	HTA1150	312	V1022160 (159)	723
H2000W	286	H3152	268	H3406	269	H3573-49	299	HTA1152A	314	V1030150 (145)	725
H2000X	286	H3153	268	H3407	270	H3580	287	HTA1153	312	V1030350 (592)	725
H2000XA	286	H3162	307	H3432	301	H3583	287	HTA1154	312	V1030410 (596)	725
H2002	286	H3183	281	H3433	296	H3586	287	HTA1156	312	V1030550 (597)	726
H2150	268	H3183A	281	H3434	296	H3595	287	HTA1216	312	V1030650 (597P)	726
H2151	268	H3183B	281	H3437	267	H3601	270	HTA1308	312	V1040150 (140)	726
H2153	268	H3183C	281	H3440	287	H3604	269	HTA1312A	314	V1040160 (141)	726
H2155	268	H3192	288	H3444	265	H3609	270, 271	HTA1312B	314	V1040250 (142)	726
H2157	268	H3237DA	293	H3448	271	H3612	270, 271	HTA1312C	314	V1040260 (143)	726
H2158	268	H3241	296	H3456	281	H3614	270, 271	HTA1401	313	V1040350 (5490)	727
H2159	268	H3262	307	H3501	284	H3616	270, 272	HTA1402	313	V1040360 (5492)	727
H2161	268	H3264	308	H3502	265	H3630	305, 323	HTA1403	313	V1040450 (5491)	727
H2162	268	H3266	308	H3502-10	265	H3650	301	HTA1404	313	V1040460 (5493)	727
H2163	268	H3274	308	H3502-11	265	H3655	301	HTA1819	314	V1040560 (5590)	727
H2164	268	H3276	308	H3502-12	265	H3659	303	HTA1820	314	V1040570 (144)	726
H2166	268	H3282	310	H3502-13	265	H3660	303	HTA1830	314	V1040650 (147)	805
H2168	268	H3284	310	H3529	275	H3661	303	HTA1831	313	V1040660 (148)	805
H2169	268	H3290	274	H3530	276	H3662	311	HTA1832	313	V1040850 (5591)	727
H2170	268	H3295	282	H3531	276	H3664	311	HTA1833	313	V1040860 (5592)	727
H2171	268	H3308	268	H3533	268	H3666	311	HTA1834	313	V1040950 (5593)	727
H2172	268	H3309	268	H3536	273	H3668	311	HTA1835	313	V1050150 (5992)	728
H2176	268	H3310	296	H3537	273	H3670	311	PCN-SP100TASHD-19		V1050260 (5993)	728
H2177	268	H3315	273	H3538	267	H3672	311		645	V1050350 (5994)	728
H2179	268	H3318	274	H3540	270	H3674	311	PCN-SP20TSHD-28	645	V1050360 (5997)	728
H2186	268	H3319	274	H3544	284	H3700	295	PCN-SP30TSHD-12	645	V1050450 (5992P)	728
H2188	268	H3327	287	H3560	290	H3700-10	295	PCN-SP50TSHD-24	645	V1050460 (5993P)	728
H3041	280	H3341	288	H3562	289	H3700-11	295	PCN-SP75TSHD-24	645	V1050550 (6978)	728
H3041B	280	H3342	263	H3565	288	H3700-12	295	PEL-21-2	557	V1050560 (6980)	728
H3041C	280	H3344	302	H3566	289	H3700-13	295	PEL-21-3	557	V1050570 (6976)	728
H3041D	280	H3346	287	H3573	299	H3700-14	295	PEL-21-4	557	V1050650 (6979)	728
H3042	277	H3351	284	H3573-10	299	H3700-15	295	PEL-21-5	557	V1050660 (6989)	728
H3042A	277	H3352	285	H3573-11	299	H3700-16	295	PEL-21-6	557	V1050850 (6981)	730
H3042B	277	H3353	285	H3573-12	299	H3700-17	295	PUT-QCR401		V1050860 (6982)	730
H3042C	277	H3354	285	H3573-13	299	H3700-18	295	-INSERT	509	V1050950 (6984)	730
H3042D	277	H3355	285	H3573-14	299	H3700-19	295	PUT-QCR401-SC	509	V1050960 (6985)	730
H3042K	277	H3356	285	H3573-15	299	H3700-20	295	V1010140 (6693)	721	V1051150 (6990)	729
H3047	267	H3357	285	H3573-16	299	H3700-21	295	V1010150 (6692)	721	V105115R (6990R)	729
H3052	293	H3358	285	H3573-17	299	H3700-22	295	V1010340 (6696)	721	V1051160 (6991)	729
H3055	296	H3359	285	H3573-18	299	H3700-23	295	V1010350 (6697)	721	V1051170 (6992)	729
H3056	297	H3362-10	311	H3573-19	299	H3702	295	V1010510 (693)	720	V1051250 (6995)	730
H3060	272	H3362-11	311	H3573-20	299	H3702-10	295	V1010610 (694)	720	V1051260 (6996)	730
H3061	272	H3362-12	311	H3573-21	299	H3702-11	295	V1010670 (694BK)	720	V1051270 (6997)	730
H3068	302	H3362-13	311	H3573-22	299	H3702-12	295	V1010710 (695)	720	V1051350 (6986)	729
H3070	262	H3362-14	311	H3573-23	299	H3702-13	295	V1010850 (6694)	721	V1051360 (6987)	729
H3071	272	H3362-15	311	H3573-24	299	H3704	304	V1010860 (6695)	721	V1051370 (6988)	729
H3078	296	H3362-16	311	H3573-25	299	H3704-10	64	V1010950 (696)	722	V1051450 (6993)	731
H3079	296	H3362-17	311	H3573-26	299	H3704-14	64	V1020160 (131)	722	V1051460 (6994)	731
H3089	284	H3362-18	311	H3573-27	299	H3704-16	64	V1020250 (134)	722	V1051470 (6998)	731
H3090	296	H3362-19	311	H3573-28	299	H3704-18	64	V1020350 (6698)	725	V1051510 (6999)	729
H3095	297	H3362-20	311	H3573-29	299	H3704-22	64	V1020460 (6699)	725	V1052150 (6900)	729
H3096	297	H3364	284	H3573-30	299	HTA1000	313	V1020750 (6926)	723	V1052160 (6901)	729
H3103	306	H3370	295	H3573-31	299	HTA1106	312	V1020810 (6927)	723	V1052250 (6904)	730
H3105	294	H3371	295	H3573-32	299	HTA1108A	314	V1020951 (6930)	722	V1052260 (6905)	730
H3107	270	H3372	295	H3573-33	299	HTA1109	312	V1021061 (6931)	722	V1060150 (6920)	732
H3116	304	H3373	295	H3573-34	299	HTA1117	314	V1021150 (6935)	723	V1060260 (6921)	732
H3125	300	H3374	295	H3573-35	299	HTA1118	312	V1021170 (6937)	723	V1060270 (6921BK)	732
H3128	275	H3375	295	H3573-36	299	HTA1118A	314	V1021260 (6936)	723	V1060350	
H3129	275	H3376	295	H3573-37	299	HTA1118B	314	V1021450 (6932)	724	(6924)	731, 744
H3143	282	H3377	295	H3573-38	299	HTA1125	312	V1021470 (6933BK)	724	V1060460	
H3148	283	H3378	295	H3573-39	299	HTA1136	312	V1021560 (6933)	724	(6925)	731, 744

V1060471 (6925BK).....	731, 744	V1140250 (D7125OP).....	741	V2060450 (5546)...	739	V2510850 (6914A).	762	V3010140 (101).....	796	V3246440 (J34 345H).....	792
V1060550 (6940)...	731	V1140260 (D7125YP).....	741	V2060480 (5545)...	739	V2510860 (6916A).	762	V3010160 (101).....	796	V3246640 (P34 060).....	792
V1060560 (6941)...	731	V1150150 (5030)...	751	V2060550 (5538)...	738	V2520210 (5558A)	765	V3010460 (577).....	797	V3246850 (P30 060).....	791
V1060570 (6942)...	731	V1150160 (5031)...	751	V2060570 (5536BK).....	738	V252021T (5558AT).....	765	V3010461 (577B)...	797	V3246950 (J25 261H).....	793
V1070150 (6001)...	737	V1150170 (5031BK)	751	V2060580 (5536)...	738	V2520250 (5555)...	765	V3010560 (577J)...	797	V3246960 (H25 501)	793
V1070161 (5999A).	737	V1150250 (5032)...	751	V206095A (5540A).....	738	V252025T (5555T)	765	V3010660 (577P)...	797	V3246970 (A25 48)	793
V1070180 (6003)...	737	V1150260 (5033)...	751	V206097A (5539BKA).....	738	V2520270 (5558BK)	765	V3010760 (581)...	797	V3247420	
V1070250 (6001J).	736	V1160150 (5518)...	735	V206098A (5539A).....	738	V2520310 (5559)...	765	V3020140 (D7000)	794	V3247420 (JP33 250H).....	792
V1070260 (5999J).	736	V1160160 (5519)...	735	V2240140 (A43 48).....	775	V252031T (5559T)	765	V3020180 (D7000)	794	V3247920 (SL35 155).....	791
V1070280 (6003J).	736	V116016T (5519T).	735	V2240540 (H43 501).....	775	V2520970 (5558BW).....	766	V3020340 (D7020)	794	V3510160 (571).....	772
V1070350 (6001P).	736	V1160170 (5519BK)	735	V2240640 (J43 380).....	774	V2540150 (7701)...	759	V3030150 (D1000)	741	V3510360 (578)...	772
V1070360 (5999P).	736	V116017T (5519BKT).....	735	V2241020 (P43 035).....	774	V254015T (7701T).....	758, 759	V3030250 (D1003)	741	V3510460 (579)...	772
V1070380 (6003P).	736	V1160250 (6618)...	735	V2241340 (P43 085).....	774	V2540180 (7700).....	758, 759	V3030760 (D9000)	795	V3510560 (580)...	772
V1070450 (6002)...	737	V1160260 (6619)...	735	V2241740 (C43 320).....	774	V254018T (7700T).....	758, 759	V3031140 (D9010)	795	V3520150 (5892)...	778
V1070460 (6000)...	737	V1160270 (6619BK)	735	V2241940 (J43 320)	774	V2540250 (7711)...	759	V3031160 (D9010)	795	V3520160 (5894)...	778
V1070480 (6004)...	737	V1170150 (5015)...	733	V22421340 (P43 085).....	774	V2540280 (7710)...	759	V3031340 (D9020)	795	V3520170 (5894BK)	778
V1080150 (5598)...	752	V1170160 (5016)...	733	V22421740 (P43 320).....	774	V2540370 (7734)...	760	V3031360 (D9020)	795	V3520250 (5893)...	778
V1080160 (5599)...	752	V1170170 (5017)...	733	V22424640 (J43 380).....	774	V2540370 (7735)...	760	V3035060 (D5050)	796	V3520260 (5895)...	778
V1080170 (5599BK)	752	V1180160 (5660)...	732	V2243650 (R80)...	773	V2540380 (7736)...	760	V3035070 (D5050)	796	V3520270 (5895BK)	778
V1080250 (5608)...	752	V1190160 (6007)...	753	V2243950 (R85)...	773	V2540370 (7735)...	760	V3040140 (583)...	798	V3520350 (5896)...	779
V1080260 (5609)...	752	V1190260 (6009)...	753	V2246120 (H160 501).....	776	V2540380 (7736)...	760	V3040180 (883)...	798	V3520360 (5897)...	779
V1080350 (5618)...	752	V1190360 (6037)...	754	V2246450 (J160 400).....	776	V2540430 (7741)...	761	V3040340 (D8120J).....	801	V3520450 (5898)...	779
V1080360 (5619)...	752	V1190460 (6039)...	754	V2246750 (P160 041).....	776	V2540440 (7742)...	761	V3040360 (D8120J).....	801	V4010170 (560-A)	805
V1090150 (5594)...	740	V1200250 (5400)...	742	V2340120 (AP 100).....	827	V2540450 (7743)...	761	V3040440 (D8120P).....	801	V4010410 (561)...	807
V1090160 (5596)...	740	V1200260 (5401)...	742	V2340240 (AP 200).....	827	V2540540 (7762)...	761	V3040460 (D8120P).....	801	V4010420 (562)...	807
V1090250 (5595)...	740	V1200350 (5400H)	742	V2340340 (BIB 100).....	828	V2540540 (7762)...	761	V3050200 (700)...	798	V4010550 (567)...	806
V1090260 (5597)...	740	V1200360 (5401H)	742	V2340440 (CS 100).....	828	V2550210 (5554)...	764	V3060170 (150P)...	800	V4010560 (569)...	806
V1090350 (5600)...	740	V1200450 (5401)...	742	V2340500 (WJ 150).....	827	V2550210 (5566)...	764	V3060210 (2100)...	800	V4010570 (570)...	806
V1090360 (5601)...	740	V1200460 (5405)...	742	V2340620 (WJ 250).....	827	V2550250 (5573)...	764	V3060220 (2101)...	800	V4020151 (5568A)	805
V1100150 (5579)...	732	V2010110 (5133)...	784	V2340720 (WJ 100).....	827	V2560111 (5522A).	767	V3060470 (D2020)	800	V4020171 (5562A)	805
V1100160 (5589)...	732	V201011T (5133T).	784	V2340840 (WP 100).....	828	V2560111 (5522A).	767	V3060640 (DK115J).....	799	V4020251 (5569A)	805
V1110150 (5574A)...	744	V2010380 (5134)...	785	V2340920 (SL 100).....	828	V2560151 (5532A).	767	V3060680 (DK115J).....	799	V4020271 (5560A)	805
V1110250 (5575A).	744	V201038T (5134T).	785	V2349020 (SP 5).....	829	V2560151 (5532A).	767	V3060840 (DK115P).....	799	V4020351 (5564A)	806
V1110350 (5576)...	745	V2020180 (512)...	785	V2349820 (63058).....	829	V2560151 (5532A).	767	V308029A (400A).	802	V4020361 (5567A)	806
V1110360 (5586)...	745	V2020380 (515)...	784	V2440260 (P163 041).....	777	V2560210 (5523)...	767	V308029B (400B).	802	V4020371 (5563A)	806
V1110450 (5578)...	745	V202038T (515T)...	784	V2440550 (P161 041).....	777	V2560210 (5523)...	767	V3080391 (415A).	802	V4020711 (5570A)	806
V1110460 (5588)...	745	V2020510 (5514)...	734	V2440620 (H162 502).....	777	V2560250 (5533)...	767	V3080392 (415B).	802	V4030270 (5502)...	807
V1110660 (5585A).	744	V202051T (5514T).	734	V2440650 (H161 502).....	777	V2560250 (5533)...	767	V3080393 (415SS).	803	V4030370 (5503)...	807
V1110950 (D8125J)	743	V2020580 (5516)...	734	V2440660 (H163 502).....	777	V2560270 (337)...	769	V3080396 (415BG)	803	V4030470 (5504)...	807
V1110960 (D8125J)	743	V202058T (5516T).	734	V2440670 (H162 502).....	777	V2570170 (335)...	769	V3080410 (418)...	803	V4030570 (5505)...	808
V1111050 (D8125P)	743	V2020680 (516)...	734	V2440680 (H162 502).....	777	V2570270 (337)...	769	V3080590 (420)...	803	V4030670 (5506)...	808
V1111060 (D8125P)	743	V202068T (516T)...	734	V2440690 (H162 502).....	777	V2570450 (338SF).	768	V3080690 (414)...	802	V4240140 (B105FUL.GR).....	822
V1111150 (D8125H)	743	V2020680 (516)...	734	V2440720 (H162 502).....	777	V2570470 (337SF).	768	V3100270 (D2200M).....	804	V4240360 (B405FUL.YL).....	823
V1111160 (D8125H)	743	V202068T (516T)...	734	V2440750 (H162 502).....	777	V2570570 (334)...	769	V3240860 (SL11 180).....	775	V4240440 (B405SOF.GR).....	823
V1120151 (5020BB)	746	V2020680 (516)...	734	V2440760 (H162 502).....	777	V2570670 (334SF).	769	V3240870 (SL11 200).....	775	V4240500 (B405FUL.WH).....	823
V1120161 (5021BB)	746	V202068T (516T)...	734	V2440770 (H162 502).....	777	V2570770 (335SF).	769	V3240960 (A11 48)	775	V4240640 (B405FUL.GR).....	823
V1120350 (5022)...	747	V2020680 (516)...	734	V2440780 (H162 502).....	777	V2570870 (356)...	770	V3241420 (J136 347H).....	790	V4510870 (564A)...	780
V1120360 (5023)...	747	V2020680 (516)...	734	V2440790 (H162 502).....	777	V2570970 (359)...	770	V3241620 (P136 070).....	790	V4510970 (565A)...	780
V1120470 (5025)...	746	V2020680 (516)...	734	V2440800 (H162 502).....	777	V2580110 (330)...	771	V3242040 (J35 345H).....	790	V4511070 (566A)...	780
V1120651 (5040BB)	748	V2020680 (516)...	734	V2440810 (H162 502).....	777	V2580310 (333)...	771	V3242120 (P35 060).....	790	V4512070 (5665A)...	780
V1120661 (5041BB)	748	V2020680 (516)...	734	V2440820 (H162 502).....	777	V2580370 (333BK)	771	V3242200 (P35 060).....	790	V4520170 (666)...	782
V1120850 (5043)...	748	V2020680 (516)...	734	V2440830 (H162 502).....	777	V2580380 (333)...	771	V3245050 (P25 025)	793	V4520270 (C200)...	781
V1120860 (5044)...	748	V2020680 (516)...	734	V2440840 (H162 502).....	777	V2580550 (339SF)	771	V3246250 (J30 345H).....	791	V4520370 (C201)...	781
V1120870 (5042)...	748	V2020680 (516)...	734	V2440850 (H162 502).....	777	V2580570 (340SF)	771	V3246420 (A30 48)	791	V4520470 (C202)...	781
V1120950 (5046)...	747	V2020680 (516)...	734	V2440860 (H162 502).....	777	V2590280 (473)...	768			V4520510 (C207)...	781
V1120960 (5047)...	747	V2020680 (516)...	734	V2440870 (H162 502).....	777	V2590380 (474)...	768			V4520570 (C207BK)	781
V1122150 (5051)...	746	V2020680 (516)...	734	V2440880 (H162 502).....	777	V2591470 (4401)...	770			V4520710 (C214)...	782
V1122160 (5052)...	746	V2020680 (516)...	734	V2440890 (H162 502).....	777	V2592470 (4402)...	770				
V1130150 (5200)...	749	V2020680 (516)...	734	V2440900 (H162 502).....	777						
V1130160 (5201)...	749	V2020680 (516)...	734	V2440910 (H162 502).....	777						
V1130250 (5205)...	749	V2020680 (516)...	734	V2440920 (H162							

V4520770 (C214BK) 782	V5070160 (556)..... 843	V6201010 (189)..... 851	V810112X (SA-1002-X)..... 873	V8252196 (FBH-10000A1040-6) 888	V860005 (BAG-005) 890, 891
V4520970 (C215)..... 782	V5070260 (558)..... 843	V6210150 (191)..... 851	V810120X (SA-20000-X)..... 873	V825301X (PIP1-X) 887	V860120 (CP-03015-1)..... 891
V4610130 (1026)..... 818	V5070360 (559)..... 843	V6210250 (192)..... 851	V810122X (SA-200022-X)..... 873	V825302X (PIP2-X) 887	V860121 (CP-03015-2)..... 891
V4610170 (1025)..... 818	V5070400 (659)..... 843	V6220170 (201)..... 851	V8103162 (SA-3206-2)..... 874	V825307X (PIP7-X) 887	V860130 (CP-04011-1)..... 891
V4610330 (1028)..... 818	V5070650 (846)..... 844	V6220270 (202)..... 851	V8103172 (SA-3207-2)..... 874	V825521_ (FBH10020A1020-X) 869	V860140 (RA-100) 891
V4610370 (1027)..... 818	V5080100 (530B)..... 844	V6220370 (203)..... 851	V810410X (SA-3400-X)..... 874	V8255211 (FBH10020A1020-S) 869	V860151 (CP-41210-1)..... 890, 891
V4610530 (1032)..... 818	V5080200 (535FLRF)..... 846	V6220490 (286)..... 853	V810415X (SA-3402-6A)..... 874	V8255212 (FBH10020A1020-M) 869	V860152 (CP-41210-2) 890, 891
V4610570 (1031)..... 818	V5080300 (535TL) 846	V6220590 (287)..... 853	V810426A (SA-3402-6A)..... 874	V8255213 (FBH10020A1020-L) 869	V860301 (FBH-PAD)..... 891
V4610730 (1034)..... 818	V5080400 (536KN)..... 845	V6220870 (298)..... 852	V810415X (SA-3405-X)..... 874	V8255214 (FBH10020A1020-XL) 869	V860302 (CP-14010)..... 891
V4610770 (1033)..... 818	V5080500 (536L)..... 845	V6241840 (RH 100)..... 828	V810420X (SA-44000-X)..... 874	V8255215 (FBH10020A1020-XXL) 869	V860303 (CP-23300-1)..... 891
V4610830 (1051)..... 819	V5080600 (536LW)..... 845	V6300160 (301)..... 853	V810422X (SA-44022-X)..... 874	V825522_ (FBH10000A1020-X) 869	V860304 (CP-22300-1)..... 891
V4610870 (1050)..... 819	V5080800 (536PL)..... 845	V6300260 (302)..... 853	V810425X (SA-44055-X)..... 874	V825562_ (FBH60110A1020-X) 869	V860402 (RFID-1)..... 891
V4710170 (1011)..... 819	V5080900 (537FLRF)..... 844	V7012140 (2021B) 815	V8104306 (SA-7400-6)..... 874	V825564_ (FBH10000L1020-X) 869	V860901 891, 912
V4710270 (1022)..... 819	V5081000 (555FLRF)..... 847	V7012150 (2021)..... 815	V8104326 (SA-7402-6)..... 874	V825565_ (FBH10000E1020-X) 869	V865240 (T-LINE-40)..... 876
V4710580 (9679)..... 820	V5081200 (630)..... 847	V7012250 (2022)..... 815	V8104406 (SA-84000-6)..... 874	V825702X (RK2-X)..... 886	V865280 (T-LINE-80)..... 876
V4710680 (9685)..... 820	V5081300 (631BR) 847	V7012350 (2023)..... 815	V8104426 (SA-84022-6)..... 874	V825703X (RK3-X)..... 886	
V4720170 (1040)..... 821	V5081400 (632)..... 845	V7013550 (2035)..... 810	V810810X (SA-4500-X)..... 874	V825704X (RK4-X)..... 886	
V4720270 (1041)..... 821	V5081600 (655)..... 847	V7013650 (2036)..... 810	V810812X (SA-4502-X)..... 874	V8257055 (RK5-50) 886	
V4720370 (1042)..... 821	V5081700 (656)..... 848	V7013750 (2037)..... 811	V810822X (SA-4522-X)..... 874	V83010 (RG-11010) 882	
V4720470 (1043)..... 821	V5081800 (658)..... 848	V7014550 (2045)..... 811	V810822X (SA-4522-X)..... 874	V83011 (RG-11000) 882	
V4800110 (120)..... 824	V5081900 (662A) 845	V7015550 (2055)..... 812	V810822X (SA-4522-X)..... 874	V83012 (RG-21000) 882	
V4800290 (123)..... 825	V5082000 (627PB)..... 846	V7015650 (2056)..... 813	V815100X (LAN-1222-X)..... 875	V83021 (CG-9001) 882	
V4800370 (124B)..... 825	V5082200 (6632PT)..... 846	V7016550 (2065)..... 814	V815120X (LAN-1242-X)..... 875	V84013XXX (VL-1115-X)..... 883	
V4800410 (P305)..... 824	V5240020 (251)..... 830	V7030200 (350)..... 809	V815120X (LAN-1242-X)..... 875	V84014XXX (VL-1125-X)..... 883	
V4800510 (P411)..... 824	V5240130 (HS 366) 830	V7030300 (355)..... 809	V81540X (LAN-3400-X)..... 875	V84511008 (SRL-10301-8)..... 879	
V4810170 (1098)..... 824	V5240330 (667L)..... 831	V7030400 (360)..... 809	V81542X (LAN-3402-X)..... 875	V84537065 (MW-65G)..... 890	
V5010170 (5311)..... 834	V5240430 (695FL) 830	V7030900 (390)..... 809	V820310X (RAS3-X)..... 881	V845423012 (SRL-40302-12)..... 879	
V5010260 (5322)..... 834	V5240820 (341S)..... 829	V8001000 (FBH-10002A) 864, 866	V820350X (CAS-X)..... 881	V845423018 (SRL-40302-18)..... 879	
V5010340 (5330)..... 834	V5241120 (312)..... 829	V8002000 (FBH-10000A) 864, 867	V820800X (AS-21000-X)..... 881	V845523006LE (SRL-50302-6LE)..... 879	
V5010440 (5333)..... 835	V5241220 (341)..... 829	V8002010 (FBH-10000B)..... 867	V820840X (AS-21210-X)..... 881	V845525007LE (SRL-50502-7LE)..... 879	
V5010560 (5355)..... 835	V5241440 (777L)..... 829	V8002020 (FBH-10000L)..... 867	V820860X (AS-21110-X)..... 881	V845526007LE (SRL-50602-7LE)..... 879	
V5010650 (544)..... 834	V5241540 (799L)..... 829	V8002030 (FBH-10000E)..... 867	V8221111 (CP-10011-1)..... 880	V845533020LE (SRL-53302-20LE)..... 879	
V5020100 (531)..... 835	V5241620 (852)..... 830	V8002060 (FBH-10000J)..... 867	V8221112 (CP-10011-2)..... 880	V845533040LE (SRL-53302-40LE)..... 879	
V5020200 (531W) 835	V5241720 (856)..... 830	V8002200 (FBH-10020A)..... 867	V8221113 (CP-10011-3)..... 880	V845533060LE (SRL-53302-60LE)..... 879	
V5020300 (535)..... 837	V5241820 (858)..... 830	V8002210 (FBH-10020B)..... 867	V8221114 (CP-10010-1)..... 880	V845534060 (SRL-53303-60)..... 879	
V5020400 (536)..... 835	V5241920 (858)..... 830	V8006100 (FBH-60110A) 864, 868	V8221115 (CP-10010-2)..... 880	V845534108 (SRL-53303-108)..... 879	
V5020500 (536HVO)..... 836	V6010150 (772)..... 853	V8006110 (FBH-60110A) 864, 868	V8221121 (CP-12010-2)..... 880	V8460 (SRL-53303-BRKT) 890	
V5020700 (536HVVY)..... 836	V6010250 (777)..... 853	V8006200 (FBH-60110B)..... 868	V8221210 (CP-12010-1)..... 880	V85011 (TR-100)..... 890	
V5020900 (536P)..... 836	V6010450 (778)..... 853	V8006120 (FBH-60110L)..... 868	V8222130 (CP-11010-1)..... 880	V85024 (CSK1-60) 890	
V5021000 (536U)..... 835	V6020260 (177)..... 852	V8006210 (FBH-60120A)..... 868	V82229001 (RB-9701)..... 880	V85025 (CSK2-65) 890	
V5021100 (537)..... 836	V6020360 (176)..... 852	V8006210 (FBH-60120B)..... 868	V8229100 (RB-9800)..... 880	V85026 (CSK3-60) 890	
V5021400 (537U)..... 836	V6040600 (103121)..... 912	V805101_ (WB-1010-X)..... 870	V8229104 (RB-9900)..... 880	V855121 (RES-Q-POLE)..... 889	
V5021500 (537XL) 836	V6040700 (171001)..... 912	V8051011 (WB-1010-S)..... 870	V8229104 (RB-9900)..... 880	V855130 (CP-15300-3)..... 890	
V5021700 (543)..... 837	V6041000 (DISPLAYRACK)..... 912	V8051012 (WB-1010-M)..... 870	V8252034 (FK-004) 888	V85523100 (RES-Q-KIT 100')..... 889	
V5022000 (545)..... 838	V6042200 (T4WR12) 913	V8051012 (WB-1010-L)..... 870	V8252036 (FK-003) 888	V860001 (BAG-001)..... 891	
V5022100 (547)..... 838	V6042200 (T4WR25)..... 913	V8051014 (WB-1010-XL)..... 870	V8252096 (FK-001) 888	V860004 (BAG-004)..... 891	
V5022200 (555)..... 838	V6042300 (T4WR37)..... 913	V8051015 (WB-1010-XXL)..... 870	V8252116 (FK-002) 888		
V5022300 (834)..... 839	V6042400 (T4WR49)..... 913	V805601_ (WB-6010-X)..... 870			
V5022400 (836)..... 836	V6042500 (T4WS49)..... 913	V805602_ (WB-6020-X)..... 870			
V5022500 (836U)..... 836	V6042600 (TM24X49)..... 912	V8059 (WB-6006)..... 870			
V5022600 (845)..... 839	V6061000 (XY106) 912	V810110X (SA-1000-X)..... 873			
V5040700 (890)..... 837	V6200150 (180P)..... 850	V8101116 (SA-1040-6)..... 873			
V5040900 (891)..... 837	V6200350 (181)..... 850				
V5050100 (542)..... 831	V6200450 (181P)..... 850				
V5050200 (5441)..... 831	V6200550 (183)..... 850				
V5050300 (844)..... 831	V6200650 (183P)..... 850				
V5050500 (830)..... 831					
V5060100 (525)..... 840					
V5060200 (533)..... 840					
V5060300 (540)..... 841					
V5060400 (541)..... 841					
V5060500 (551)..... 840					
V5060700 (568)..... 841					
V5060820 (5688)..... 841					
V5060910 (501)..... 842					
V5060920 (502)..... 842					
V5060930 (503)..... 842					
V5060940 (504)..... 842					

TRADEMARKS

Audi and the names of specific products/Models are the registered trademarks of AUDI AG.

BENDIX is a registered trademark of Bendix Commercial Vehicle Systems, LLC

CAT and Caterpillar are registered trademarks of Caterpillar Inc.

Cummins is a trademark of Cummins Inc.

Detroit Diesel is a registered trademark of Detroit Diesel Corp.

Ford and the names of specific products/models are the registered trademarks of Ford Motor Company

GM, Chevrolet, Pontiac, Oldsmobile, Buick, Cadillac, GMC, Blazer and HUMMER are registered trademarks of General Motors of Canada Limited (GMCL)

Honda is a registered trademark of Honda Motor Co., Ltd

International Harvester is a registered trademarks of CNH Global N.V.

ISUZU and the names of specific Isuzu products are trademarks of Isuzu Motors Limited or Isuzu Motors America, LLC,

Jeep, Wrangler, Cherokee, Grand Cherokee, Dodge, RAM and other models are trademarks of Chrysler Group LLC

John Deere is a registered trademark of Deere & Company

Kubota is a registered trademark of Kubota Tractor Corporation

Land Rover is a registered trademark of Land Rover Canada, Rover Group Limited

Leyland is a registered trademark of LEYLAND TRUCKS LIMITED

MacPherson struts is a registered trademark of Ford Motor Corporation

Mazda and the names of specific products/models are the registered trademarks of Mazda Motor Corporation

MERCEDES BENZ is a registered trademark of DaimlerChrysler Corp.

Mini and BMW, and the names of specific products/Models are the registered trademarks of Bayerische Motoren Werke Aktiengesellschaft

Mitsubishi and the names of specific products/models are the registered trademarks of Mitsubishi Motors Corporation

Navistar is a registered trademark of Navistar Int. Transportation Corp

Nissan and the names of specific products/models are the registered trademarks of Nissan Motor Co. Ltd

Renault is a registered trademark of Renault s.a.s. Corporation

SCANIA is a trademark of Scania CV Aktiebolag

Subaru is a registered trademark of Subaru division of Fuji Heavy Industries, Ltd, Japan.

Toyota, and the names of specific products/models are the registered trademarks of Toyota Motor Corporation

Volkswagen is a trademark of Volkswagen AG.

Volvo and the names of specific products/models are the registered trademarks of AB Volvo and Volvo Car Corporation

AdBlue® is a registered trademark of the VDA (Verband der Automobilindustrie)

Arrow®, T50, T-25 and JT-21 are trademarks of Arrow Fastener Co., Inc.

Erickson® is a trademark of Kennametal Inc.

Jacobs® is a registered trademark of The Jacobs Chuck Manufacturing Co.

Kevlar® is a registered trademark of E. I. du Pont de Nemours and Company

Teflon® is a registered trademarks of E. I. du Pont de Nemours and Company

Torx® is a registered trademark of Acument Intellectual Properties, LLC.

Viton is a registered trademark of DuPont Performance Elastomers L.L.C.

ANSI® is a registered trademark of American National Standards Institute

ASTM® is a registered trademark of ASTM International

Contender 88® is a registered trademark of Contender Composite Inc.

CoolPass® is a registered trademark of Jiangsu Hengli Chemical Fiber Co., Ltd.

Cordura® is a registered trademark of Invista

CSA® is a registered trademark of CSA Group

De Clermont® is a registered trademark of De Clermont SAS

Dry King®, Trail Pak®, Storm Master®, Flame-Gard®, CA-43®, Petro-Gard®, Utili-Gard®, Clipper®, FL Snapper®, Snapper® are registered trademarks of JET Equipment & Tools Ltd.

Eurowear™, StarTech™, FR-Tech™, Element FR™ are trademarks of JET Equipment & Tools Ltd.

GelFlex® is a registered trademark of Versaflex Inc.

Kevlar® is a registered trademark of E. I. du Pont de Nemours and Company

NFPA® is a registered trademark of the National Fire Protection Association

Nomex® is a registered trademark of E. I. du Pont de Nemours and Company

Protex® is a registered trademark of Kaneka Corporation

Radiantex® is a registered trademark of Texel Inc.

Reflexite® is a registered trademark of Orafol Americas Inc.

Scotchlite® is a registered trademark of 3M Company

Thermolite® is a registered trademark of LBP Manufacturing, Inc.

Thinsulate® is a registered trademark of 3M Company

Wellmax Flex-05® is a registered trademark of Wellmax Products Co., Ltd.

Vehicle manufacturers' names and models, are used in this catalogue as a common reference point and for no other reason.

JET Equipment & Tools Ltd. does not sponsor or endorse said manufacturers. All trademarks are the property of respective owners.

JET Equipment & Tools Ltd.® is a registered trademark of JET Equipment & Tools Ltd.®

JET-KUT® is a registered trademark of JET Equipment & Tools Ltd.®

POWER PLUS® is a registered trademark of JET Equipment & Tools Ltd.®

POWERBLEND® is a registered trademark of JET Equipment & Tools Ltd.®

POWERFLEX® is a registered trademark of JET Equipment & Tools Ltd.®

SUMO® is a registered trademark of JET Equipment & Tools Ltd.®

SUPER CHOP® is a registered trademark of JET Equipment & Tools Ltd.®

TORQUE DRIVE® is a registered trademark of JET Equipment & Tools Ltd.®

POWER XTREME® is a registered trademark of JET Equipment & Tools Ltd.®

SureWerx™ is a registered trademark of JET Equipment & Tools Ltd.®

PeakWorks® is a registered trademark of JET Equipment & Tools Ltd.®

Ranpro® is a registered trademark of JET Equipment & Tools Ltd.®

Sellstrom® is a registered trademark of Sellstrom.®

Pioneer® is a registered trademark of JET Equipment & Tools Ltd.®

Strongarm® is a registered trademark of JET Equipment & Tools Ltd.®

DISCLAIMER:

JET Equipment & Tools Ltd. (JET) makes every effort to maintain the accuracy and quality of the information provided in this catalogue. However, JET cannot guarantee and assumes no legal liability or responsibility for the accuracy or completeness of the information provided. The information contained in this catalogue is for general guidance only. You should take appropriate professional advice on your particular circumstances because the application of our equipment may vary depending on particular circumstances.

The copyright of all content in this catalogue is owned by JET Equipment & Tools Ltd. and/or the various manufacturers of our products. No part of the SureWerx catalogue may be changed, reproduced, stored in or transmitted on any website or medium without the prior written permission of JET Equipment & Tools Ltd. Requests to republish any material must be sent to marketing@surewerx.com. In case of any questions or remarks, feel free to contact us.



Our products are available from a broad distribution network throughout Canada. We support this network with our own system of warehouses in Vancouver, Edmonton, Winnipeg, Toronto, Montreal and Halifax. This distribution network ensures fast deliveries and superior service to our customers.

Date of publication March, 2016



Western Canada & Territories
(Vancouver Customer Service Centre)

Toll Free Tel.: 1-800-472-7685
Toll Free Fax: 1-800-663-7742
Sales Tel.: 604-523-7600
Sales Fax: 604-523-7693

Ontario & Quebec
(Toronto Customer Service Centre)

Toll Free Tel.: 1-800-387-3879
Toll Free Tel.: 1-800-363-2885 (French)
Toll Free Fax: 1-800-267-3310
Sales Tel.: 905-565-8661
Sales Fax: 905-565-7266

Head Office (Vancouver)

Tel.: 604-523-TOOL (8665)
Fax: 604-526-JET1 (5381)

Atlantic Canada

Toll Free Tel.: 1-800-472-7686
Toll Free Fax: 1-877-468-3461
Sales Tel.: 902-468-8324
Sales Fax: 902-468-3461



OUR FAMILY OF TOOL, EQUIPMENT & SAFETY BRANDS



surewerx.com

\$19.95

899921

