

ONE OF THE COUNTRY'S LEADING CAUSES OF TRUCK RELATED ACCIDENTS ARE DUE TO BRAKES THAT ARE OUT OF ADJUSTMENT. **BRAKESAFE** IS THE INDUSTRY'S SOLUTION. BY TELLING THE DRIVER IF HIS BRAKES ARE IN OR OUT OF ADJUSTMENT, THE **BRAKESAFE** UNIT HELPS DRIVERS AVOID THE FINES AND LOST POINTS AWARDED FOR OUT OF ADJUSTMENT BRAKES.

## DRIVER BENEFITS

- CONDUCT A VISUAL AIR BRAKE AND SPRING BRAKE INSPECTION IN LESS THAN 5 MINUTES.
- REDUCES EQUIPMENT DOWNTIME DUE TO INSPECTION AND UNNECESSARY BRAKE ADJUSTMENT.
- ELIMINATES FINES AND LOST CVOR POINT FOR OUT OF ADJUSTMENT BRAKES.

## MAINTENANCE BENEFITS

- QUICKLY AND ACCURATELY IDENTIFIES AIR BRAKE CHAMBERS THAT ARE IN OR OUT OF ADJUSTMENT.
- IDENTIFIES WEAK OR BROKEN EMERGENCY BRAKE SPRINGS.
- IDENTIFIES WORN, DEFECTIVE, SEIZED OR INCORRECTLY SETUP MANUAL OR AUTOMATIC SLACK ADJUSTERS.
- IDENTIFIES CRACKED OR OUT OF ROUND BRAKE DRUMS.
- PROMOTES BALANCED BRAKING, EXTENDING TIRE LIFE.
- SAVES THOUSANDS OF SHOP LABOUR HOURS ANNUALLY, TROUBLESHOOTING BRAKE DEFECTS AND NEEDLESSLY ADJUSTING AIR BRAKES.

## FEATURES

- HEAVY DUTY, PLATED STEEL BRACKET BOLTS TO BRAKE CHAMBER IN MINUTES.
- PRE-MEASURED REFERENCE UNIT AVAILABLE IN DOT/CVSA SPECIFIED SIZES.
- TOOLED CLEVIS PIN PROVIDES ACCURATE MEASUREMENT WITH OR WITHOUT BRIGHT COLOURED COVERS.
- HIGHLY VISIBLE RED POINTER BETWEEN THE CENTERS OF THE TWO YELLOW REFERENCE PINS INDICATES AIR BRAKES ARE IN ADJUSTMENT.
- UNIVERSAL FORMATS FOR TRUCKS AND TRAILERS.

# VISUAL BRAKE STROKE INDICATOR

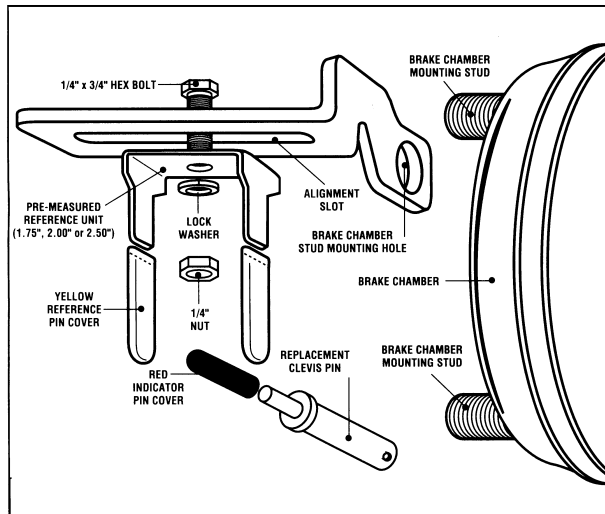

**NOTE:** Properly installed, the yellow reference pins and the red clevis indicator pin **do not** touch or interfere. Pins are aligned centre to centre.

## UNIVERSAL TRUCK BRACKETS (POWER UNITS)

PART #	CLEVIS PIN SIZE	CHAMBER SIZE	REF. UNIT WIDTH	APPLICATION INFORMATION
PU242	1/2"	16,20,24	1-3/4"	MOST STEERING AXLES
PU242-58	5/8"	16,20,24	1-3/4"	STEERING AXLES 5/8"
PU250LS	1/2"	30LS	2-1/2"	LONG STROKE, SQUARE PORT CHAMBERS
PU250LS-58	5/8"	30LS	2-1/2"	LONG STROKE, SQ. PRT CHAMBERS - 5/8"
PU302	1/2"	30,16L,20L,24L	2"	MOST DRIVE AXLES AND LONG STROKES
PU302-58	5/8"	30,16L,20L,24L	2"	DRIVE AXLES AND LONG STROKES - 5/8"
PU302E	1/2"	30, EXTENDED	2"	MACK CAMELBACK AND LONGER PUSHRODS
CP250LS	CLAMP	30	2-1/2"	TRANSIT BUS APPLICATIONS-TYPE 30 LONG STROKE
CP302	CLAMP	30	2"	TRANSIT BUS APPLICATIONS-TYPE 30 LONG REGULAR

## MISCELLANEOUS PARTS

PART #	PRODUCT	APPLICATION INFORMATION
RP1	PIN COVER	FOR CLEVIS PIN (RED)
YP2	PIN COVER	FOR REFERENCE PINS (YELLOW)
CLVS58	CLEVIS PINS	ALL SLACK ADJUSTERS WITH 5/8" CLEVIS PINS
CLVS12	CLEVIS PINS	ALL SLACK ADJUSTERS WITH 1/2" CLEVIS PINS

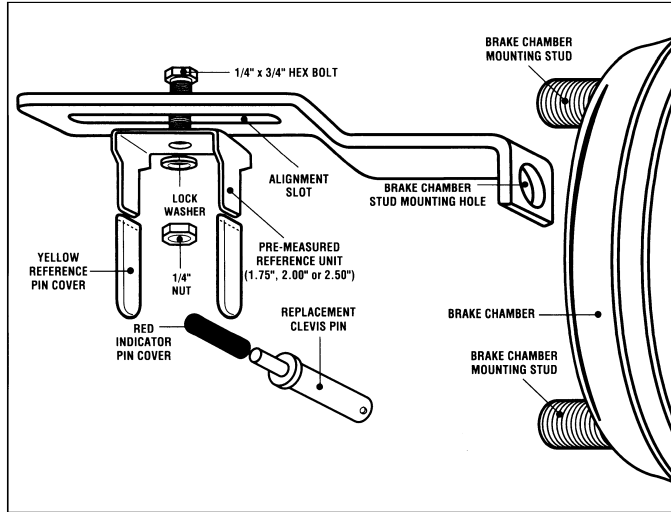

**NOTE:** Properly installed, the yellow reference pins and the red clevis indicator pin **do not** touch or interfere. Pins are aligned centre to centre.

## UNIVERSAL TRAILER BRACKETS (POWER UNITS)

PART #	CLEVIS PIN SIZE	CHAMBER SIZE	REF. UNIT WIDTH	APPLICATION INFORMATION
TL250LS	1/2"	30LS	2-1/2"	LONG STROKE, SQUARE PORT CHAMBERS
TL250LS-58	5/8"	30LS	2-1/2"	LONG STROKE, SQ. PRT CHAMBERS - 5/8"
TL302	1/2"	30	2"	FLATBED, VAN & TANKER TRAILERS.
TL302-58	5/8"	30	2"	FLATBED, VAN & TANKER TRAILERS - 5/8"
TL302S	1/2"	30- SHORT BRACKET	2"	LOW-FLOAT TRAILERS

## INTRAAX AND EXTENDED PUSHRODS

PART #	CLEVIS PIN SIZE	CHAMBER SIZE	REF. UNIT WIDTH
TL250LS-CP	CLAMP	30	2-1/2"
TL302-CP	CLAMP	30	2"

## CLAMP INDICATOR PIN (CIP) ASSEMBLY

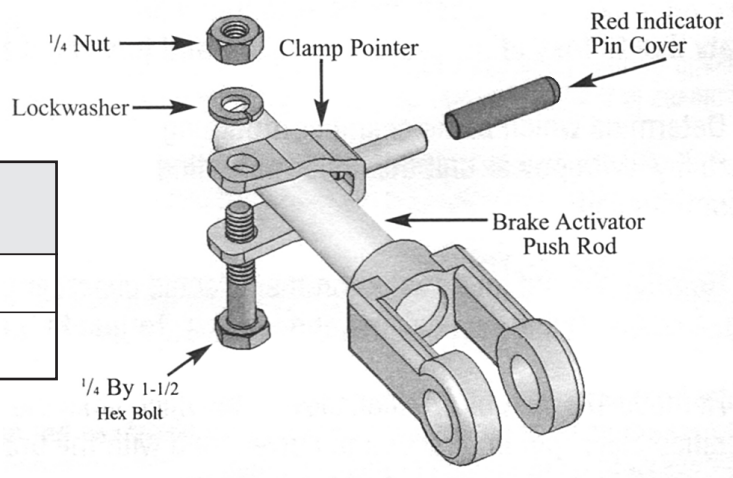

# MANUAL SLACK ADJUSTERS

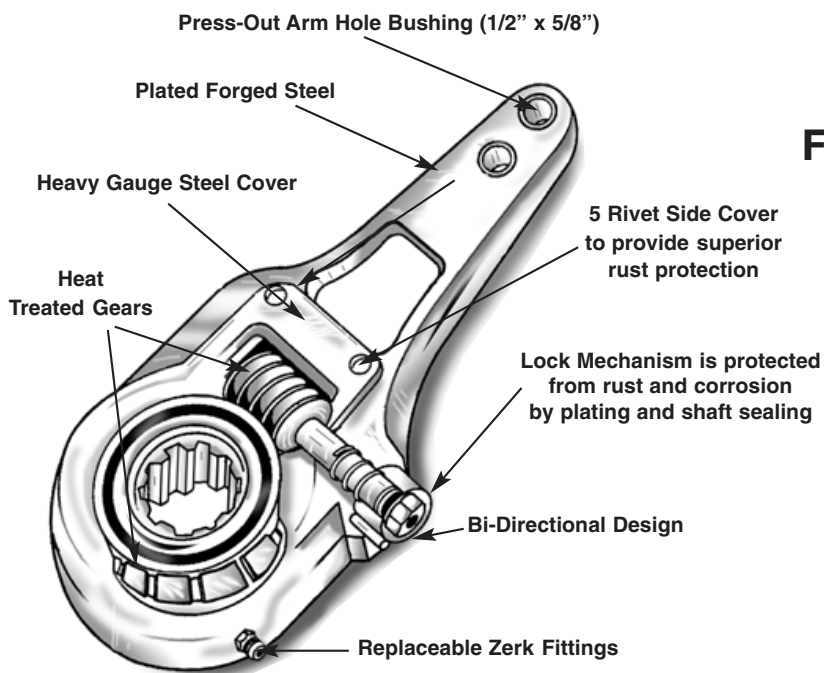

## FEATURES AND BENEFITS

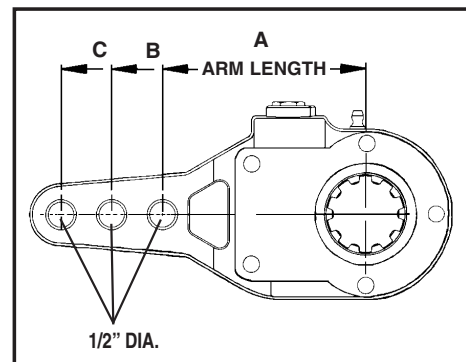

STRAIGHT ARM - 10 SPLINE					
PART #	ARM LENGTH			DIAMETER SPLINE	APPLICATIONS
	A	B	C		
MSA100	4-1/2	5-1/2	----	1-1/4" -10	STANDARD STEER AXLE
MSA101	5	6	----	1-1/4" -10	STANDARD STEER AXLE
MSA105	5	6	7	1-1/2" -10	POPULAR TRAILER AXLE
MSA105HD	5	6	7	1-1/2" -10	POPULAR TRAILER AXLE (30,000 LB. CAPACITY)
MSA106	5-1/2	6-1/2	----	1-1/2" -10	POPULAR DRIVE AXLE
MSA106HD	5-1/2	6-1/2	----	1-1/2" -10	POPULAR DRIVE AXLE (30,000 LB. CAPACITY)
STRAIGHT ARM - 24 OR 28 SPLINE					
PART #	ARM LENGTH			DIAMETER SPLINE	APPLICATIONS
	A	B	C		
MSA103	5-1/2	----	----	1-1/4 - 24	STANDARD STEER AXLE
MSA111	5-1/2	6-1/2	----	1-1/2 - 28	POPULAR DRIVE AXLE
MSA111HD	5-1/2	6-1/2	----	1-1/2 - 28	POPULAR DRIVE AXLE (30,000 LB. CAPACITY)
MSA112	5	6	7	1-1/2 - 28	POPULAR TRAILER AXLE
MSA112HD	5	6	7	1-1/2 - 28	POPULAR TRAILER AXLE (30,000 LB. CAPACITY)
STRAIGHT ARM - 37 SPLINE					
PART #	ARM LENGTH			DIAMETER SPLINE	APPLICATIONS
	A	B	C		
MSA113	6	----	----	1-37/64 - 37	FRUEHAUF AXLE



# MANUAL SLACK ADJUSTERS

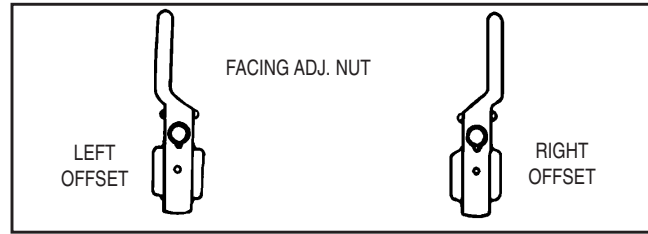
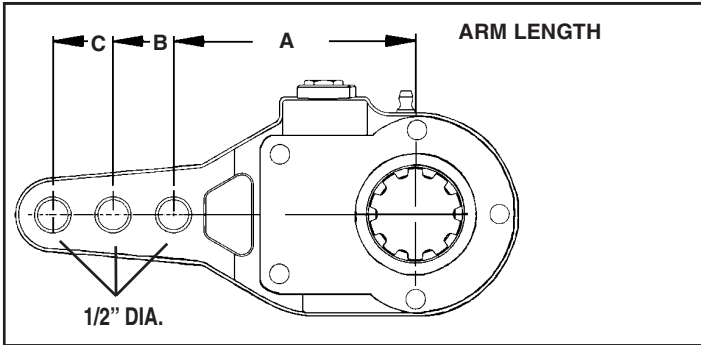

## 1 1/2" OFFSET ARM

PART #	ARM LENGTH			DIAMETER SPLINE	APPLICATIONS
	A	B	C		
MSA108R	5	6	----	1-1/2 -10	OFFSET FOR STEER AXLE
MSA108L	5	6	----	1-1/2 -10	
MSA109R	5-1/2	6-1/2	----	1-1/2 -10	
MSA109L	5-1/2	6-1/2	----	1-1/2 -10	
MSA118R	7	----	----	1-1/2 -10	
MSA118L	7	----	----	1-1/2 -10	

## 5/8" OFFSET ARM

PART #	ARM LENGTH			DIAMETER SPLINE	APPLICATIONS
	A	B	C		
MSA102R	4-1/2	5-1/2	----	1-1/4-10	OFFSET FOR STEER AXLE
MSA102L	4-1/2	5-1/2	----	1-1/4-10	
MSA104R	4-1/2	5-1/2	----	1-1/4-24	
MSA104L	4-1/2	5-1/2	----	1-1/4-24	
MSA117R	5-1/4	----	----	1-1/2-10	
MSA117L	5-1/4	----	----	1-1/2-10	
MSA107R	6	7	----	1-1/2-10	
MSA107L	6	7	----	1-1/2-10	
MSA116R	6	7	----	1-1/2-28	
MSA116L	6	7	----	1-1/2-28	

## CURVED ARM

PART #	ARM LENGTH	DIAMETER SPLINE	APPLICATIONS
MSA110	6	1 1/2-10	CURVED ARM FOR 12-1/4" BRAKES
MSA114	6	1 1/2-28	

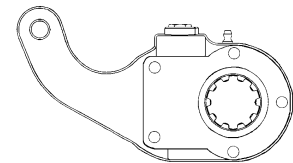

## ARM BUSHING

PART #	ARM LENGTH	
	O.D.	I.D.
MSA500	5/8	1/2

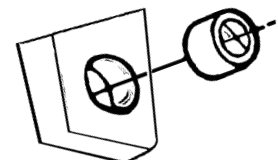

# MANUAL SLACK ADJUSTERS

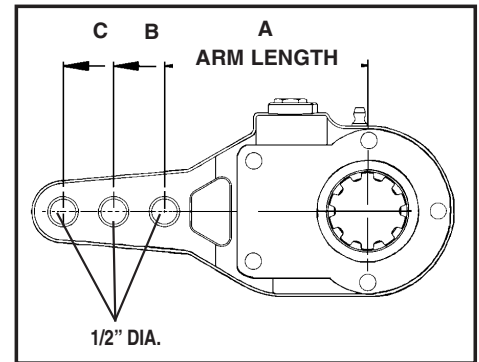
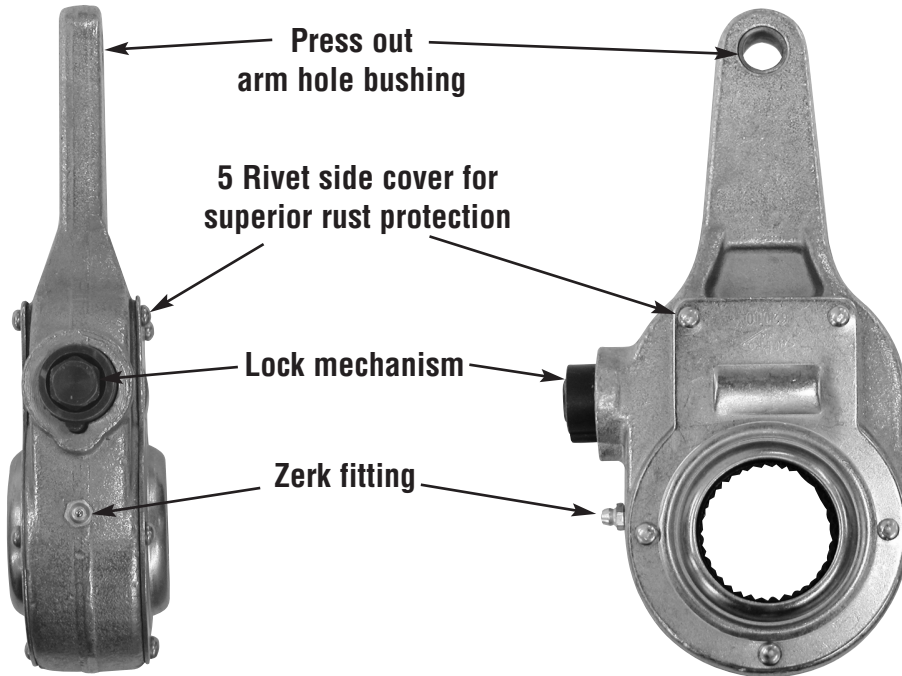

**IMPORTED**

STRAIGHT ARM - 10 SPLINE					
PART #	ARM LENGTH			DIAMETER SPLINE	APPLICATIONS
	A	B	C		
MSA105A	5	6	7	1-1/2" -10	POPULAR TRAILER AXLE
MSA106A	5-1/2	6-1/2	----	1-1/2" -10	POPULAR DRIVE AXLE
STRAIGHT ARM - 24 OR 28 SPLINE					
PART #	ARM LENGTH			DIAMETER SPLINE	APPLICATIONS
	A	B	C		
MSA111A	5-1/2	6-1/2	----	1-1/2 - 28	POPULAR DRIVE AXLE
MSA112A	5	6	7	1-1/2 - 28	POPULAR TRAILER AXLE
STRAIGHT ARM - 37 SPLINE					
PART #	ARM LENGTH			DIAMETER SPLINE	APPLICATIONS
	A	B	C		
MSA113A	6	----	----	1-37/64 - 37	FRUEHAUF AXLE



# AUTOMATIC SLACK ADJUSTERS

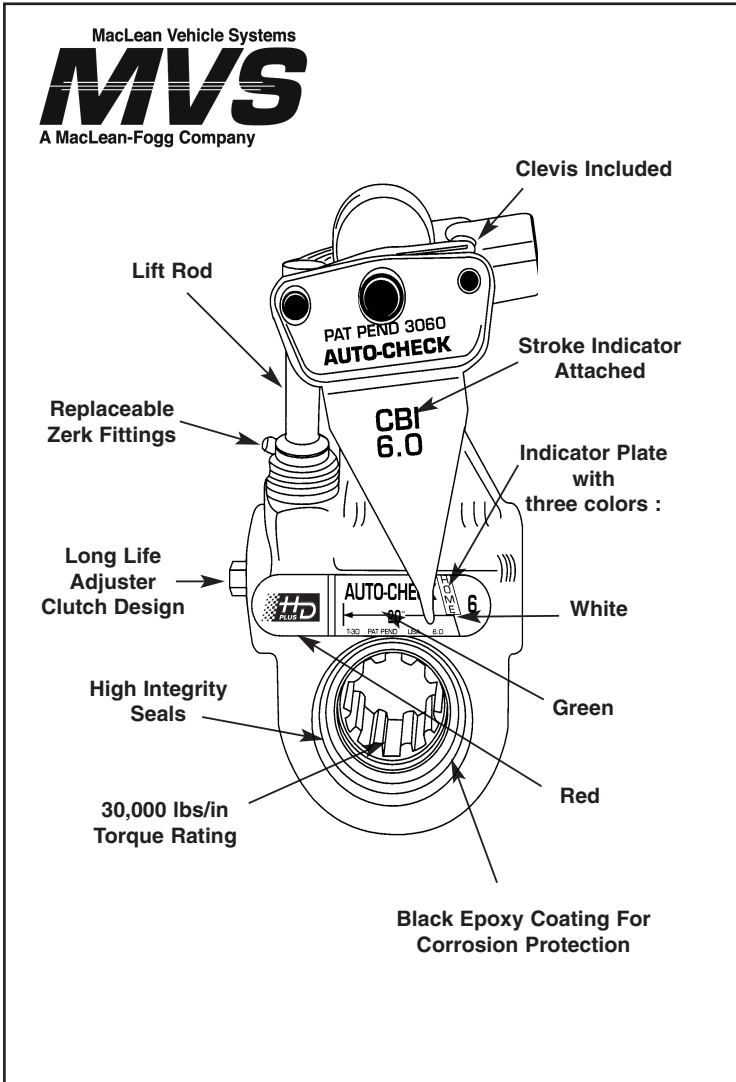

## FEATURES AND BENEFITS

- STROKE INDICATOR ATTACHED TO THE A.S.A. ELIMINATES THE NEED TO CRAWL UNDER VEHICLES.
- INDICATES BOTH THE CORRECT HOME/SET UP POSITION AND THE AIR CHAMBER STROKE, JUST BY LOOKING:
  - WHITE AREA: CORRECT HOME/SET UP POSITION
  - GREEN AREA: NORMAL WORKING STROKE
  - RED AREA: BRAKE STROKE IS PAST, RE-ADJUST LIMIT
- AUTO-CHECK ALSO OFFERS EXTRA QUALITY CONTROL CHECK FOR INSTALLER, OR REPAIR SHOP TO CONFIRM THE CORRECT SET UP. IF PROPERLY INSTALLED THE POINTER WILL BE IN THE AREA MARKED "HOME".
- AUTO-CHECK IS CLEARANCE SENSING TO MAINTAIN PROPER SHOE TO DRUM CONTACT, STROKE ADJUSTMENT ON THE RETURN LIFT ROD, WITH ONE PIECE CLEVIS. "NO EXTERNAL BRACKET REQUIRED".
- EASY INSTALLATION TOOL ENCLOSED WITH SLACK
- ALL ARE SOLD IN COMPLETE KIT (CLEVIS-CLEVIS PIN & INSTALLATION TEMPLATE)

## STRAIGHT ARM - 10 SPLINE

PART #	ARM LENGTH	DIA./SPLINE	CHAMBER SIZE	APPLICATIONS
ASA100	5-1/2	1-1/4 - 10	20 or 24	STEER AXLE (CLEVIS 5/8X18)
ASA101	6	1-1/4 - 10	30	STEER AXLE (CLEVIS 5/8X18)
ASA105	6	1-1/2 - 10	30	TRAILER AXLES
ASA205	6	1-1/2 - 10	30	TRAILER AXLES, EXTENDED CLEVIS
ASA106	5-1/2	1-1/2 - 10	30	DRIVE AXLES
ASA122	6-1/2	1-1/2 - 10	30	DRIVE AXLES
ASA105-LS	6	1-1/2 - 10	30	TRAILER LONG STROKE
ASA106-LS	5-1/2	1-1/2 - 10	30	TRUCK LONG STROKE
ASA120	5-1/2	1-1/4 - 10	16	STEER AXLE (CLEVIS 1/2X20)
ASA125	5-1/2	1-1/4 - 10	30	STEER AXLE (CLEVIS 5/8X18)

# AUTOMATIC SLACK ADJUSTERS



## STRAIGHT ARM - 24 OR 28 SPLINE

PART #	ARM LENGTH	DIA./SPLINE	CHAMBER SIZE	APPLICATIONS
ASA103	5-1/2	1-1/4 -24	20 OR 24	STEER AXLE (CLEVIS 5/8 X18)
ASA103-6	6	1-1/4 -24	30	STEER AXLE (CLEVIS 5/8 X18)
ASA111	5-1/2	1-1/2-28	30	DRIVE AXLES
ASA211	5-1/2	1-1/2-28	30	DRIVE AXLES, EXTENDED CLEVIS
ASA112	6	1-1/2-28	30	TRAILER AXLES
ASA212	6	1-1/2-28	30	TRAILER AXLES, EXTENDED CLEVIS
ASA111-LS	5-1/2	1-1/2-28	30	TRUCK LONG STROKE
ASA123	6-1/2	1-1/2-28	30	DRIVE AXLES
ASA112-LS	6	1-1/2-28	30	TRAILER LONG STROKE
ASA121	5-1/2	1-1/4-24	16	STEER AXLE (CLEVIS 1/2 X 20)
ASA126	5-1/2	1-1/4-24	30	STEER AXLE (CLEVIS 5/8 X18)

## STRAIGHT ARM - 37 SPLINE

PART #	ARM LENGTH	DIA./SPLINE	CHAMBER SIZE	APPLICATIONS
ASA113	6	1-5/8 -37	30	FRUEHAUF TRAILER AXLES
ASA113-LS	6	1-5/8 37	30	TRAILER LONG STROKE

**GENERATION II** PAT. PEND  
**"WORLD'S GREATEST BRAKE ADJUSTER"**  
 FEATURING  
**CLUTCH RELEASE BUTTON**



**OLD TYPE**  
 « GOLD »

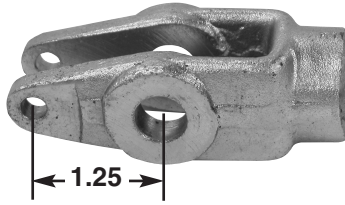

\* Pin kit included

PART #	THREAD	DESCRIPTION
ASA8110KTA	1/2" - 20	STRAIGHT CLEVIS
ASA8115KTA	1/2" - 20	OFFSET CLEVIS
ASA8120KTA*	5/8" - 18	STRAIGHT CLEVIS
ASA8125KTA	5/8" - 18	OFFSET CLEVIS

\* MOST POPULAR

**NEW TYPE**  
 « BLACK »

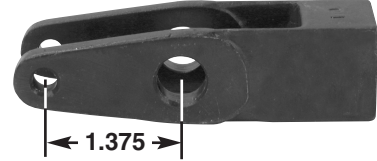

\* Pin kit included

PART #	THREAD	DESCRIPTION
ASA8410KTA	1/2" - 20	STRAIGHT CLEVIS
ASA8415KTA	1/2" - 20	OFFSET CLEVIS
ASA8420KTA*	5/8" - 18	STRAIGHT CLEVIS
ASA8425KTA	5/8" - 18	OFFSET CLEVIS
ASA8480KTA	5/8" - 18	EXTENDED STRAIGHT CLEVIS

\* MOST POPULAR



**CLEVIS PIN KIT**  
 (FOR BOTH TYPES)

**ASA8056KTA**

**AUTOMATIC SLACK ADJUSTER**

**OLD TYPE**  
 "GOLD"

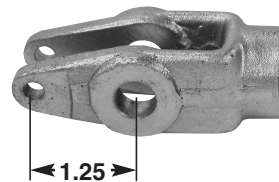

**STEEL**

**NEW TYPE**  
 "BLACK"

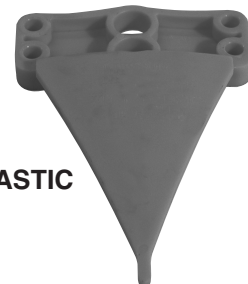

**PLASTIC**

**CREWSON AUTOMATIC SLACK ADJUSTER**

Since January 2003, Crewson has modified the spacing on the clevis from 1.25 to 1.375 inch. The installation tool has also been modified and the yellow pointer is now made of plastic instead of metal.

The old "Gold" clevis cannot be used with the new automatic slack that uses only the "Black" clevis. These are not interchangeable.

These changes will have no effect on the installation and functions of the slack.

The new Crewson slack with the "Black" clevis is shipped in an orange/black box.



## BENDIX STYLE

## FEATURES AND BENEFITS



H65344  
STANDARD AUTOMATIC  
SLACK ADJUSTER

5/8" - 18 UNF

- CLEARANCE SENSING TO MAINTAIN PROPER SHOE TO DRUM CONTACT ON BRAKE APPLICATION.
- LESS SENSITIVE TO VARYING TEMPERATURES THAN THE STROKE SENSING DESIGNS.
- INSTALLATION IS QUICK AND EASY BECAUSE THERE IS NO BRACKET OR TOOL NEEDED.
- UNHANDED DESIGN MINIMIZES INVENTORY.
- EASY MANUAL ADJUSTMENT WHEN DOING A BRAKE RELINE BY USING A 9/16" HEX WRENCH.
- WORM WITH LUBRICATION PASSAGE

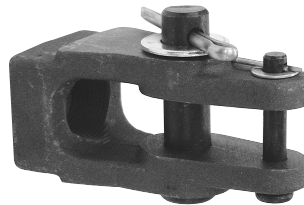

H107158  
STRAIGHT YOKE KIT



H291452  
STANDARD ADAPTER  
5/8" - 18 UNF

### STRAIGHT ARM - 10 SPLINE

PART #	ARM LENGTH	DIA./SPLINE	APPLICATION
H65700	5-1/2"	1 1/2" - 10	DRIVE AXLE
H65344	6"	1 1/2" - 10	TRAILER AXLE

### STRAIGHT ARM - 28 SPLINE

PART #	ARM LENGTH	DIA./SPLINE	APPLICATION
H65247	5-1/2"	1 1/2" - 28	DRIVE AXLE
H65175	6"	1 1/2" - 28	TRAILER AXLE

### STRAIGHT ARM - 37 SPLINE

PART #	ARM LENGTH	DIA./SPLINE	APPLICATION
H65179	6"	1 5/8"-37	FRUEHAUF AXLE

**IMPORTANT:**

The location of the pawl assembly is identified on the TYPE 1 and TYPE 2 slack adjusters.

The installation of the slack adjuster must allow for the pawl to be removed during maintenance.



TYPE 1  
(LEFT HAND)



TYPE 2  
(RIGHT HAND)



TYPE 3  
(UNHANDLED)

**STRAIGHT ARM - 10 SPLINE**

PART #	ARM LENGTH	DIA./SPLINE	TYPE	APPLICATIONS	CLEVIS
R801041	5-1/2"	1-1/2" - 10	3	STEER/DRIVE/TRAILER AXLE	R810019
R801042	6"	1-1/2" - 10	3	STEER/DRIVE/TRAILER AXLE	R810019

**STRAIGHT ARM - 28 SPLINE**

PART #	ARM LENGTH	DIA./SPLINE	TYPE	APPLICATIONS	CLEVIS
R801073	5-1/2"	1-1/2" - 28	3	STEER/DRIVE/TRAILER AXLE	R810019
R801074	6"	1-1/2" - 28	3	DRIVE/TRAILER AXLE	R810019
R802447	5-1/2"	1-1/2" - 28	2	STEER/DRIVE/TRAILER AXLE	R810019
R802487	6"	1-1/2" - 28	2	STEER/DRIVE/TRAILER AXLE	R810019
R802446	5-1/2"	1-1/2" - 28	1	STEER/DRIVE/TRAILER AXLE	R810019
R802486	6"	1-1/2" - 28	1	DRIVE/TRAILER AXLE	R810019



AUTOMATIC SLACK ADJUSTER CLEVIS PINS			
PART #	LENGTH	DIAMETER	REPLACES
R801730	1 37/64"	1/4"	19x127
R801732	1 3/4"	1/2"	19X45
R801773	1 7/8"	1/2"	19X1084, 19X60
R801774	2"	1/2"	19X1083



**R801700**  
AY PAWL ASA

PART #	CLEVIS TYPE	PUSH ROD	TECHNICAL
R810019	STRAIGHT	5/8" - 18	INCLUDES CLEVIS, PINS & CLIPS. FOR 20, 24, 30 & 36 CHAMBERS.

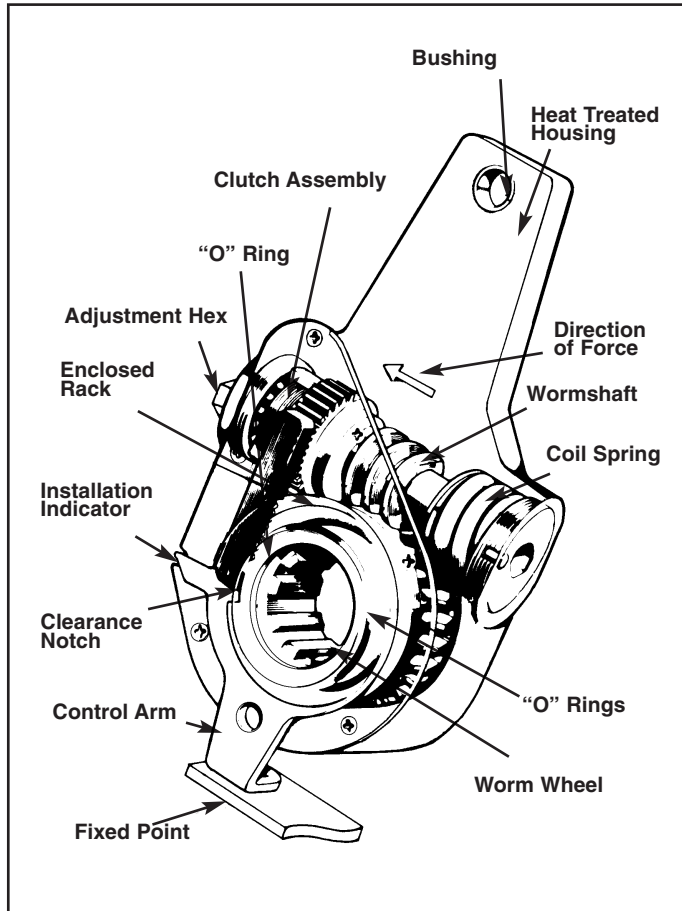

### FEATURES & BENEFITS

- EXCLUSIVE BUILT-IN "INSTALLATION INDICATOR" VISUALLY CONFIRMS CORRECT INSTALLATION.
- HALDEX AUTOMATIC BRAKE ADJUSTERS COVER MORE APPLICATIONS THAN ANY OTHER BRAND.
- #1 SELLING AUTOMATIC BRAKE ADJUSTER WITH OVER 10,000 UNITS SOLD.
- BACKED BY THE INDUSTRY'S LONGEST WARRANTY - 6 YEARS OR 750,000 MILES.
- PROVEN CLEARANCE SENSING DESIGN.
- HEAT TREATED HOUSING TO INCREASE SERVICE LIFE.

### SELECTING HALDEX AUTOMATIC SLACK ADJUSTERS

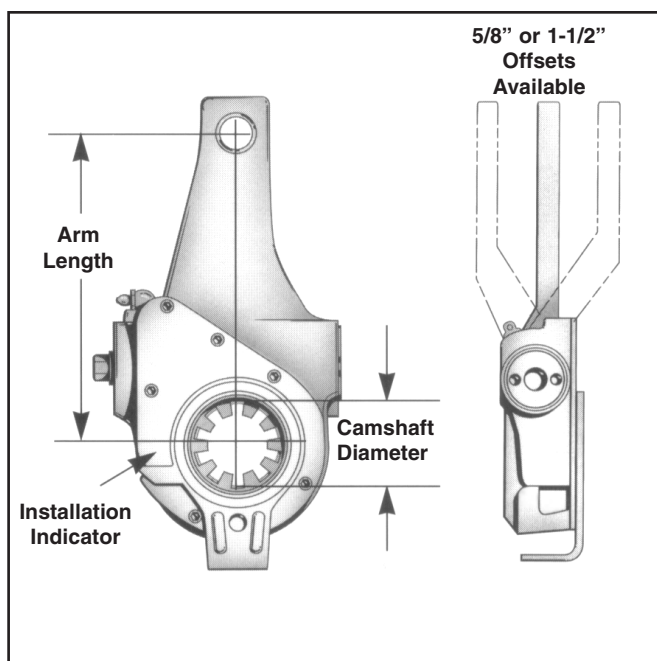

- STEP 1- DETERMINE WHAT AXLE ADJUSTER WILL BE USED ON, SEE TYPICALS ON FOLLOWING PAGES.
- STEP 2- DETERMINE THE CAMSHAFT DIAMETER AND NUMBER OF SPLINES.
- STEP 3- DETERMINE THE ADJUSTER ARM LENGTH.
- STEP 4- SELECT THE PROPER BRAKE ADJUSTER.

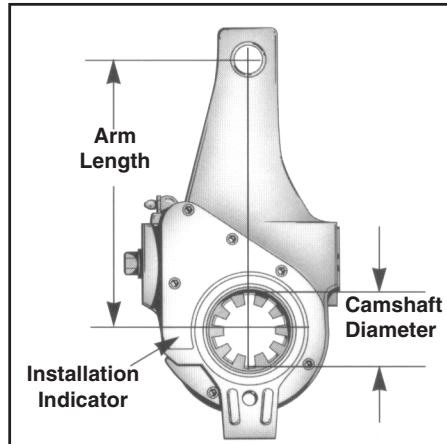

### STRAIGHT ARM - 10 SPLINE

PART #	ARM LENGTH	DIA./SPLINE	APPLICATIONS	BRACKET KIT #
40010001	5-1/2	1-1/4 - 10	STANDARD STEER AXLE	42710566
40010005	5-1/2	1-1/2 - 10	STANDARD STEER AXLE	42710566
40010142	5 - 6	1-1/2 - 10	STANDARD DRIVE AXLE	42710553
40010143	5-1/2 - 6-1/2	1-1/2 - 10	STANDARD DRIVE AXLE	42710553
40010145	6	1-1/2 - 10	MACK DRIVE AXLE	42710566
40010216	6	1-1/2 - 10	TRAILER AXLE 16-1/2" BRAKE	42710563
40010215	5-1/2	1-1/2 - 10	TRAILER AXLE 16-1/2" BRAKE	42710563

### STRAIGHT ARM - 24 OR 28 SPLINE

PART #	ARM LENGTH	DIA./SPLINE	APPLICATIONS	BRACKET KIT #
40010004	5-1/2	1-1/4 - 24	STANDARD STEER AXLE	42710567
40010008	5-1/2	1-1/2 - 28	STANDARD STEER AXLE	42710566
40010140	5-6	1-1/2 - 28	STANDARD DRIVE AXLE	42710553
40010141	5-1/2 - 6-1/2	1-1/2 - 28	STANDARD DRIVE AXLE	42710553
40010402	5-1/2	1-1/2 - 28	ROCKWELL AIR DISC BRAKE	42710543
40010144	6	1-1/2 - 28	MACK DRIVE AXLE	42710566
40010146	5-1/2 - 6-1/2"	1-1/2 - 28	MACK DRIVE AXLE	42710566
40010211	5-1/2	1-1/2 - 28	TRAILER AXLE 16-1/2" BRAKE	42710563
40010212	6	1-1/2 - 28	TRAILER AXLE 16-1/2" BRAKE	42710563

### STRAIGHT ARM - 37 SPLINE

PART #	ARM LENGTH	DIA./SPLINE	APPLICATIONS	BRACKET KIT #
40010213	5-1/2"	1-5/8"	FRUEHAUF AXLE	42710563
40010214	6"	1-5/8"	FRUEHAUF AXLE	42710563

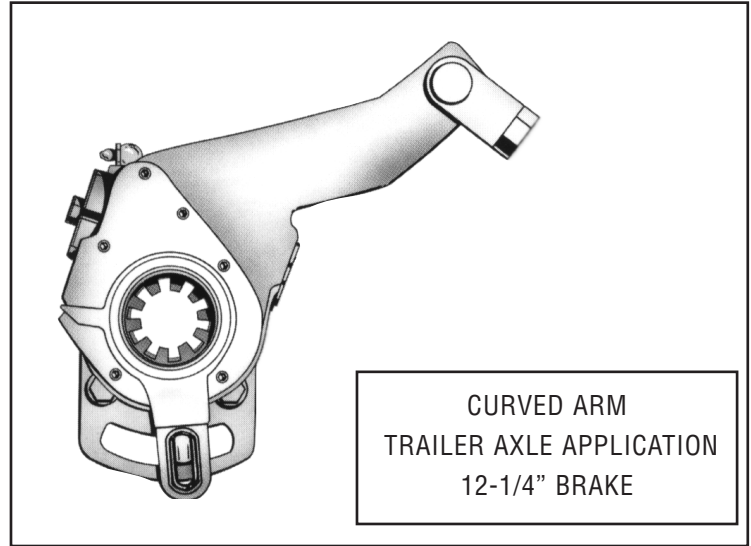
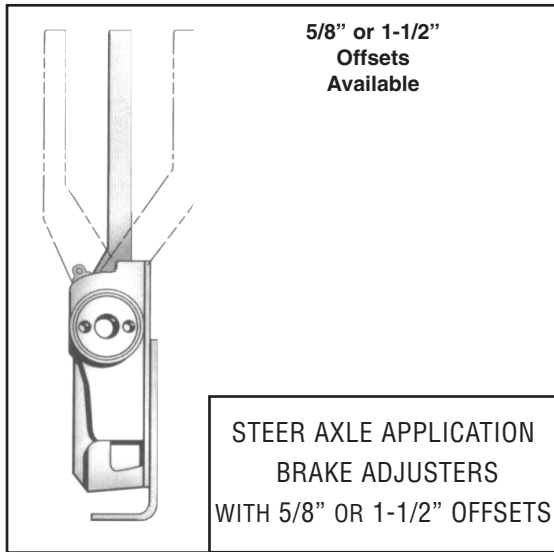

### 5/8" OFFSET ARM

PART #	POS.	ARM LENGTH	DIA./SPLINE	APPLICATIONS	BRACKET KIT #
40010002	RH	5-1/2	1-1/4 - 10	STANDARD STEER AXLE	42710566
40010003	LH	5-1/2	1-1/4 - 10		42710566
40010040	RH	5-1/2	1-1/4 - 24		42710567
40010041	LH	5-1/2	1-1/4 - 24		42710567

### 1/2" OFFSET ARM

PART #	POS.	ARM LENGTH	DIA./SPLINE	APPLICATIONS	BRACKET KIT #
40010009	RH	5-1/2	1-1/2 - 28	MACK 16,000 LBS. & GREATER STEER AXLES	42710548
40010010	LH	5-1/2	1-1/2 - 28		42710548

### CURVED ARM

PART #	ARM LENGTH	DIA./SPLINE	APPLICATIONS	BRACKET KIT #
40010304	5-1/2"	1-1/2"-28	TRAILER AXLE 12-1/4" BRAKE	42710563
40010305	6"	1-1/2"-28		42710563
40010306	6"	1-1/2"-10		42710563
40010307	6"	1-5/8"-37		42710563

## ANCHOR SCREW



PART #	DESCRIPTION
44310096	1" LG. (USE WITH THREADED ANCHOR BRACKET 7/16"-14 THREAD)
44310188	1-1/4" LG. (USE WITH SLIDE NUT 44310101)

## SLIDE NUT



PART #	DESCRIPTION
44310101	7/16"-14 THREAD X 13/16" ID

## DOUBLE BEND FLAT STUD KIT



PART #	DESCRIPTION
42710558	4 X 45210125 - BUSHINGS 4 X 44310318 - STUDS 4 X 44310204 - NUTS

## DOUBLE FLAT STUD



PART #	DESCRIPTION
44310318	3-7/8" TOTAL LENGTH, 2-3/4" LENGTH UNDER HEX TO END OF STUD, 7/16" -14 THREAD

## SERRATED HEX NUT



PART #	DESCRIPTION
44310204	7/16-14" THREAD (FOR FLAT STUD)

### PLASTIC BUSHING (BLACK OVAL)



PART #	DESCRIPTION
45210126	SINGLE BEND CONTROL LEVER PLASTIC CONTROL ARM REPLACEMENT BUSHING (13/16"OD X 9/16"ID)

### PLASTIC BUSHING (BLACK RECTANGULAR)



PART #	DESCRIPTION
45210125	PLASTIC CONTROL ARM REPLACEMENT BUSHING (1-1/4"OD X 3/4"ID)

### CLEVIS BUSHINGS



PART #	DESCRIPTION
45210058	5/8" OD X 1/2" ID (ALSO USED AS AN INSERT TO CONVERT 5/8" TO 1/2")
45210094	3/4" OD X 1/2" ID (SERRATED)

# AUTOMATIC SLACK ADJUSTERS

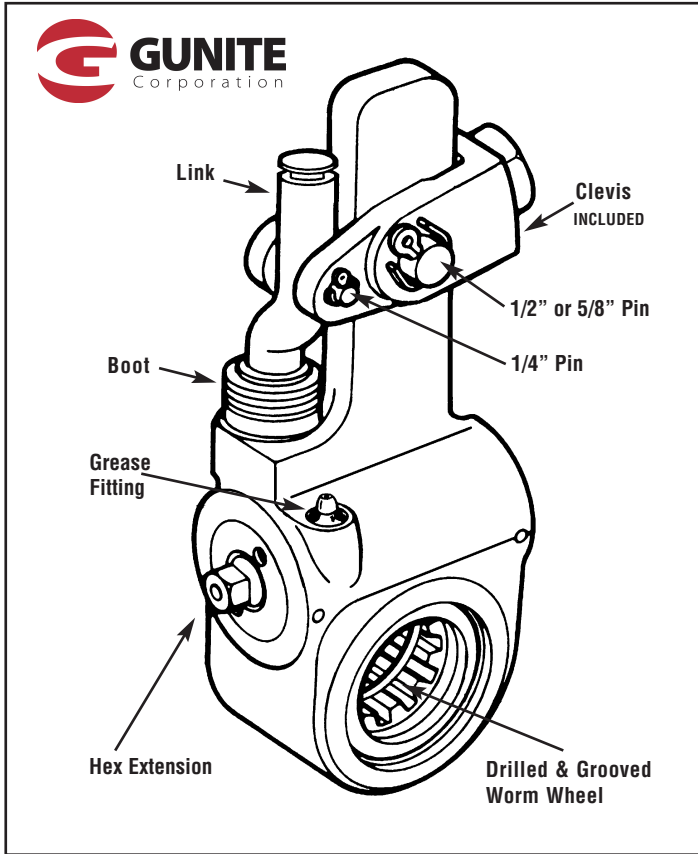

- FEATURES AND BENEFITS**
- UNHANDED DESIGN
  - COMPACT HOUSING FOR EASY INSTALLATION
  - DOUBLE SEALED ACTUATOR ARM
  - FACTORY LUBRICATED AND SEALED
  - EXTENDED LIFE CLEVIS PIN BUSHING
  - O-RING ON SPLINE GEAR

## STRAIGHT ARM (LONG STROKE) - 10 SPLINE

PART #	ARM LENGTH	DIA./SPLINE	APPLICATIONS	CLEVIS
AS1135	5	1-1/4 - 10	STEER AXLE	AS3019
AS1136	5-1/2	1-1/4 - 10	STEER AXLE	AS3019
AS1152**	5-1/2	1-1/4 - 10	STEER AXLE	AS3002
AS1153**	5-1/2	1-1/4 - 10	STEER AXLE	AS3003
AS1131	5	1-1/2 - 10	DRIVE AXLE	AS3016
AS1132	5-1/2	1-1/2 - 10	STEER / DRIVE AXLE	AS3019
AS1146*	5-1/2	1-1/2 - 10	TRAILER AXLE	AS3018
AS1156**	5-1/2	1-1/2 - 10	DRIVE AXLE	AS3003
AS1133	6	1-1/2 - 10	DRIVE AXLE	AS3016
AS1147*	6	1-1/2 - 10	TRAILER AXLE	AS3018
AS1134	6-1/2	1-1/2 - 10	DRIVE AXLE	AS3019
AS1148*	6-1/2	1-1/2 - 10	TRAILER AXLE	AS3018

\* EXTENDED CLEVIS FOR TRAILER APPLICATION INCLUDED

\*\* .625 OFFSET CLEVIS INCLUDED

# AUTOMATIC SLACK ADJUSTERS



## STRAIGHT ARM (LONG STROKE) - 24 SPLINE

PART #	ARM LENGTH	DIA./SPLINE	APPLICATIONS	CLEVIS
AS1137	5	1-1/4 - 24	STEER AXLE	AS3019
AS1138	5-1/2	1-1/4 - 24	STEER AXLE	AS3019
AS1154**	5-1/2	1-1/4 - 24	STEER AXLE	AS3002
AS1155**	5-1/2	1-1/4 - 24	STEER AXLE	AS3003

\*\* .625 OFFSET CLEVIS INCLUDED

## STRAIGHT ARM (LONG STROKE) - 28 SPLINE

PART #	ARM LENGTH	DIA./SPLINE	APPLICATIONS	CLEVIS
AS1139	5	1-1/2 - 28	DRIVE AXLE	AS3016
AS1140	5-1/2	1-1/2 - 28	STEER / DRIVE AXLE	AS3019
AS1149*	5-1/2	1-1/2 - 28	TRAILER AXLE	AS3018
AS1157**	5-1/2	1-1/2 - 28	DRIVE AXLE	AS3003
AS1141	6	1-1/2 - 28	DRIVE AXLE	AS3016
AS1150	6	1-1/2 - 28	TRAILER AXLE	AS3018
AS1142	6-1/2	1-1/2 - 28	DRIVE AXLE	AS3016
AS1151*	6-1/2	1-1/2 - 28	TRAILER AXLE	AS3018

\* EXTENDED CLEVIS FOR TRAILER APPLICATION INCLUDED  
 \*\* .625 OFFSET CLEVIS INCLUDED

## STRAIGHT ARM (LONG STROKE) -37 SPLINE

PART #	ARM LENGTH	DIA./SPLINE	APPLICATIONS
AS1143	5-1/2	1-5/8 - 37	FRUEHAUF AXLE
AS1144	6	1-5/8 - 37	FRUEHAUF AXLE
AS1145	6-1/2	1-5/8 - 37	FRUEHAUF AXLE



# CLEVIS & SLACK ADJUSTERS



## CLEVIS KITS

PART #	TYPE	STYLE	PUSH ROD THREADS
AS3000	THREADED CLEVIS	STRAIGHT	5/8 - 18
AS3001	THREADED CLEVIS	STRAIGHT	1/2 - 20
AS3002	THREADED CLEVIS	5/8" OFFSET	1/2 - 20
AS3003	THREADED CLEVIS	5/8" OFFSET	5/8 - 18
AS3011*	THREADED CLEVIS	STRAIGHT	5/8 - 18
AS3012*	THREADED CLEVIS	STRAIGHT	1/2 - 20
AS3013	EXTENDED THREADED CLEVIS	STRAIGHT	5/8 - 18
AS3015**	EXTENDED THREADED CLEVIS	STRAIGHT	5/8 - 18
AS3016	COLLAR LOCK CLEVIS	STRAIGHT	5/8 - 18
AS3017	COLLAR LOCK CLEVIS	STRAIGHT	1/2 - 20
AS3018	EXTENDED COLLAR LOCK CLEVIS	STRAIGHT	5/8 - 18
AS3019***	COLLAR LOCK CLEVIS	STRAIGHT	1/2 - 20 OR 5/8 - 18

\* FOR APPLICATIONS WITH 5/8" CLEVIS PINS

\*\* INCLUDES SAINLESS STEEL CLEVIS PINS

\*\*\* KIT CONTAINS ONE (1) 1/2" AND ONE (1) 5/8" COLLAR NUT

## SERVICE KITS

PART #	DESCRIPTION
AS4001	ONE LINK BOOT AND STEEL ARM BUSHING 1/2"
AS4003	ARM BUSHING KIT, SERVICED BY GUNAS4015
AS4004	CLEVIS PIN KIT (6 OF 1/2", 6 OF 1/4" PINS AND 12 COTTER PINS)
AS4005	24 - 5/8" STEEL ARM BUSHINGS
AS4006	CLEVIS PIN KIT (6 OF 5/8", 6 OF 1/4" PINS AND 12 COTTER PINS)
AS4007	ONE LINK BOOT AND STEEL ARM BUSHING 5/8"
AS4008	INSTALLATION GAUGE, FOR O.E.M.
AS4012	CLEVIS PIN KIT (5 OF 1/2", 5 OF 1/4" PINS AND 12 COTTER PINS) STAINLESS STEEL CLEVIS AND COTTER PINS
AS4013	COLLAR LOCK NUTS (INCLUDES 4 OF 1.25" LOCKING NUTS AND 4 OF 5/8"-18 COLLAR NUTS)
AS4014	COLLAR LOCK NUTS (INCLUDES 4 OF 1.25" LOCKING NUTS AND 4 OF 1/2"-20 COLLAR NUTS)
AS4015	ARM BUSHING KIT (24 - 1/2" STEEL ARM SUSHINGS)