

Haldex Trailer ABS Systems utilize many common valve and sensor components in all our ABS product offerings. Loom Assemblies and Electronic Control Units (ECU) will vary by ABS family. The illustrations below are representative of five families of product offerings. System identification and components reference can easily be found using these illustrations. Application notes are included in the catalog pages to aid in accurate service requirements. See ABS Service/Installation Manual L30041 for specific component usage.

Haldex ECU and Looms have mating connectors (numbers of pins and keys). Please exercise caution when replacing these items and follow the catalog references carefully. Contact your Haldex Representative if additional information is required.

## ECU Platforms



PLC Select 1M ECU  
(AL919338)



ITCM ECU  
(AL919348)

## ABS Valve Platforms



FFABS Valve  
(AL430670)

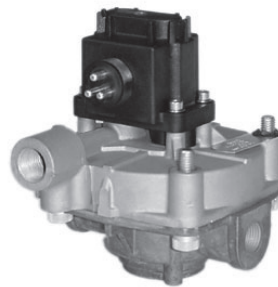

ABS Relay Valve  
(AL364040)

Requires separate Spring Brake Control Valve such as Haldex N34031A.

### Sensor Components

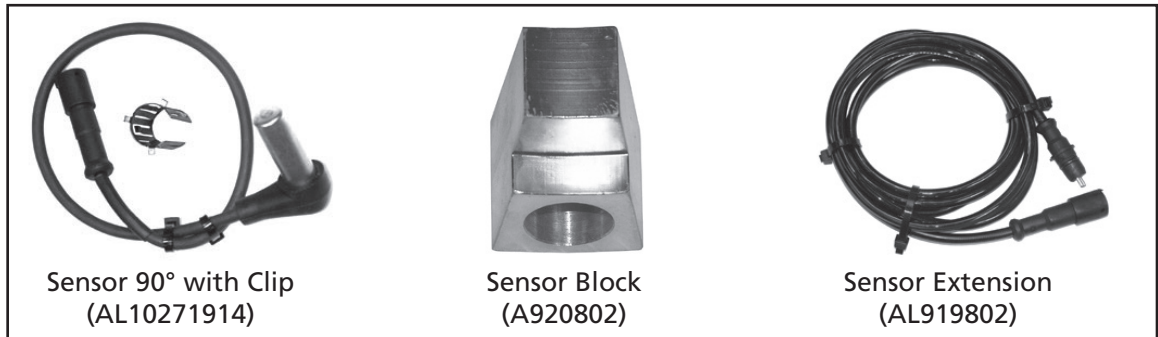

### ABS Cables



### Optional Power Cord Components

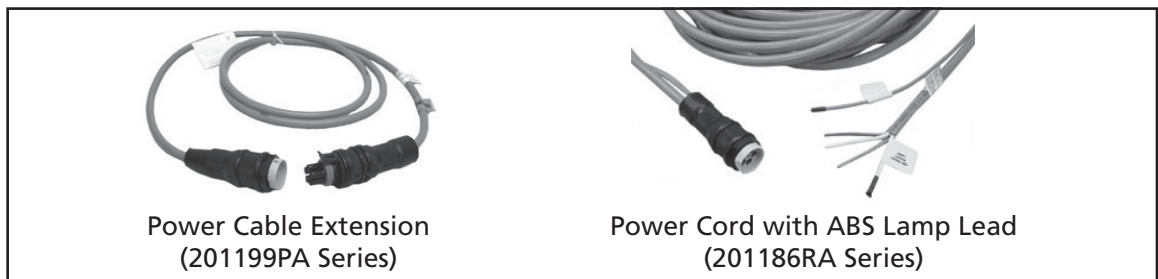

### Optional Miscellaneous Components



2S/1M ABS Relay Valve Kits  
Dollies and Single Axle Applications



**Features:**

- New trailer and competitive replacements
- Cost-effective solution for competitive system changeout
- ECU and ABS Valve designed to be serviced separately

**Specifications:**

ECU Design: PLC Select  
Valve Type: ABS Relay

**Notes:**

- 1) ABS Relay Valve system requires an additional separate spring brake control valve, such as Haldex KN26120 (N34031A).
- 2) DO NOT use this kit to replace the Haldex Full Function ABS (FFABS) System.
- 3) Most ABS maintenance involves Wheel-end Sensors. Haldex recommends that Wheel-end Sensors be replaced when replacing or upgrading the ABS System.

| Service Part No. | Product Description       | ECU/Valve Part No. | Valve Specifications  | Kit Contents other than Valve/ECU Assemblies              | OEM Part Number |
|------------------|---------------------------|--------------------|---|---|-----------------|
| AQ960505         | 2S/1M ABS Relay Valve Kit | N9001A             | 2-Port, 1/2" Reservoir Port, 12V, 3/8" Control Port, 3/8" Delivery Port | 6.0M Power Cord Extension<br>2.5M Sensors (90°) and Clips | -               |

## 2S/1M FFABS Valve Kits New Trailer Solutions / Multi-Axle Applications



AQ960208 Shown

### Features:

- For non-steer axles
- Patented FFABS Valve with integral Spring Brake Control function
- Pre-installed Reservoir Nipple with swivel and lock-nut feature assures easy servicing
- ECU and ABS Valve designed to be serviced separately

### Specifications:

ECU Design: PLC Select  
Valve Type: FFABS

### Notes:

- 1) Kit content varies see chart below for details.
- 2) Most ABS maintenance involves Wheel-end Sensors. Haldex recommends that Wheel-end Sensors be replaced when replacing or upgrading the ABS System.

| Service Part No. | Product Description   | ECU/Valve Part No. | Valve Specifications   | Kit Contents other than Valve/ECU Assemblies                                 | OEM Part Number |
|------------------|-----------------------|--------------------|--|--|-----------------|
| AQ960208         | 2S/1M FFABS Valve Kit | N9001JB            | 4-Port, Dual Nipple 1/2" & 3/4", 12V, 3/8" Ports Spring Brake Priority   | 20M Power Cord with 12M ABS Lamp Lead; 2.5M Full Sensors (90°) and Clips     | -               |
| AQ960802         | 2S/1M FFABS Valve Kit | N9001JB            | 4-Port, Dual Nipple 1/2" & 3/4", 12V, 3/8" Ports Spring Brake Priority   | 20M Power Cord with 12M ABS Lamp Lead; ABS Light Kit, 2.5M Sensor Extensions | -               |
| AQ961402         | 2S/1M FFABS Valve Kit | N9001JB            | 4-Port, Dual Nipple 1/2" & 3/4", 12V, 3/8" Ports Spring Brake Priority   | 2.5M Sensor Extensions   | -               |
| AQ961404         | 2S/1M FFABS Valve Kit | N9001JB            | 4-Port, Dual Nipple 1/2" * & 3/4", 12V, 3/8" Ports Spring Brake Priority | 6.0M Power Cord Extension, 2.5M Sensor Extensions                            | -               |

## 2S/1M ABS Relay Valve Kits Multi-Axle Applications



AQ960503 Shown

### Features:

- Competitive replacements
- For non-steer axles
- Cost-effective solution for competitive system changeout
- ECU and ABS Valve designed to be serviced separately

### Specifications:

ECU Design: PLC Select  
Valve Type: ABS Relay

### Notes:

- 1) ABS Relay Valve system requires an additional separate spring brake control valve, such as Haldex KN26120 (N34031A).
- 2) DO NOT use this kit to replace the Haldex Full Function ABS (FFABS) System.
- 3) Kit content varies see chart below for details.
- 4) AQ960514 & AQ960515 replaces MBS1, MB S1P and MBS2 (MBS2 requires optional wheel-end hardware kits to upgrade installation from in-axle sensing: AQ15457 uses Sensor Blocks, AQ15458 uses Sensor Brackets).
- 5) Most ABS maintenance involves Wheel-end Sensors. Haldex recommends that Wheel-end Sensors be replaced when replacing or upgrading the ABS System.

| Service Part No. | Product Description                                    | ECU/Valve Part No. | Valve Specifications  | Kit Contents other than Valve/ECU Assemblies  | OEM Part Number |
|------------------|--|--------------------|---|---|-----------------|
| AQ960503         | 2S/1M ABS Relay Valve Kit                              | N9001AA            | 6-Port, 1/2" Reservoir Port, 12V, 3/8" Control Port, 3/8" Delivery Port                           | 6.0M Power Cord Extension<br>3.0M Sensor Extensions   | -               |
| AQ960510         | 2S/1M ABS Relay Valve Kit                              | N9001AA            | 6-Port, 1/2" Reservoir Port, 12V, 3/8" Control Port, 3/8" Delivery Port                           | 6.0M Power Cord Extension<br>2.0M Sensor Extensions   | -               |
| AQ960514         | 2S/1M ABS Relay Valve Kit for MBS WNC Changeout (Max)  | N9001ZA            | 4-Port, 1/2" Reservoir Port, 12V, 3/8" Control Port, 3/8" Delivery Port, Special Mounting Bracket | 6.0M Power Cord Extension<br>2.5M Sensors and Clips<br>All Miscellaneous Hardware Required For Installation | -               |
| AQ960515         | 2S/1M ABS Relay Valve Kit for MBS WNC Changeout (Lite) | N9001ZA            | 4-Port, 1/2" Reservoir Port, 12V, 3/8" Control Port, 3/8" Delivery Port, Special Mounting Bracket | 6.0M Power Cord Extension<br>2.5M Sensors and Clips<br>All Miscellaneous Hardware Required For Installation | -               |

## 4S/2M FFABS Valve Kits Primarily Competitive Changeout



AQ963002 Shown

### Features:

- Cost effective solution for competitive system changeout
- Patented FFABS Valve with integral Spring Brake Control function
- Pre-installed Reservoir Nipple with swivel and lock-nut feature assures easy servicing
- ECU and ABS Valve designed to be serviced separately

### Specifications:

ECU Design: PLC Select 2M  
Valve Type: FFABS

### Notes:

- 1) Kit content varies see chart below for details.
- 2) Most ABS maintenance involves Wheel-end Sensors. Haldex recommends that Wheel-end Sensors be replaced when replacing or upgrading the ABS System.

| Service Part No. | Product Description                    | ECU/Valve Part No. | Valve Specifications   | Kit Contents other than Valve/ECU Assemblies  | OEM Part Number |
|------------------|--|--------------------|--|---|-----------------|
| AQ963002         | 4S/2M FFABS Valve Kit for Tri-Axles    | N9002JD            | 4-Port, Dual Nipple 1/2" & 3/4", 12V, 3/8" Ports Spring Brake Priority | 6.0M Power Cord Extension<br>1.5M & 2.5M Sensor Ext.<br>2-Port Relay Valve<br>2.0M Relay Valve Cable<br>Hose Clips, Cable Grips, Labels | -               |
| AQ963011         | 4S/2M FFABS Valve Kit for Tandem Axles | N9002JB            | 2-Port, Dual Nipple 1/2" & 3/4", 12V, 3/8" Ports Spring Brake Priority | 6.0M Power Cord Extension<br>1.5M & 2.5M Sensor Ext.<br>2-Port Relay Valve<br>2.0M Relay Valve Cable<br>Hose Clips, Cable Grips, Labels | -               |

4S/2M ABS Relay Valve or FFABS Valve Kits  
New Trailer Build Solutions



AQ963005 Shown

**Features:**

- ECU and ABS Valve designed to be serviced separately

**Specifications:**

ECU Design: PLC Select 2M  
Valve Type: ABS Relay or FFABS

**Notes:**

- 1) ABS Relay Valve system requires an additional separate spring brake control valve, such as Haldex KN26120 (N34031A).
- 2) Kit content varies see chart below for detail.
- 3) Most ABS maintenance involves Wheel-end Sensors. Haldex recommends that Wheel-end Sensors be replaced when replacing or upgrading the ABS System.

| Service Part No. | Product Description                        | ECU/Valve Part No. | Valve Specifications  | Kit Contents other than Valve/ECU Assemblies   | OEM Part Number |
|------------------|--|--------------------|---|--|-----------------|
| AQ963004         | 4S/2M ABS Relay Valve Kit for Tandem Axles | N9002A             | 2-Port, 1/2" Reservoir Port, 12V, 3/8" Control Port, 3/8" Delivery Port | 6.0M Power Cord Extension<br>1.5M & 2.5M Sensor Ext.<br>2-Port Relay Valve<br>2.0M Relay Valve Cable<br>Hose Clips, Cable Grips, Labels                                      | -               |
| AQ963005         | 4S/2M ABS Relay Valve Kit for Tri-Axles    | N9002AB            | 6-Port, 1/2" Reservoir Port, 12V, 3/8" Control Port, 3/8" Delivery Port | 6.0M Power Cord Extension<br>2.0M & 3.0M Sensor Ext.<br>2-Port Relay Valve<br>2.0M Relay Valve Cable<br>Hose Clips, Cable Grips, Labels                                      | -               |
| AQ963013         | 4S/2M FFABS Valve Kit for Tri-Axles        | N9002JD            | 4-Port, Dual Nipple, 1/2" & 3/4", 12V, 3/8" Ports Spring Brake Priority | 20M Power Cord with 12M ABS Lamp Lead<br>1.5M & 2.5M Sensor Ext.<br>2-Port Relay Valve<br>Warning Lamp Kit<br>Misc. Hardware & Labels  | -               |
| AQ963014         | 4S/2M FFABS Valve Kit for Tandem Axles     | N9002JB            | 2-Port, Dual Nipple, 1/2" & 3/4", 12V, 3/8" Ports Spring Brake Priority | 20M Power Cord with 12M ABS Lamp Lead<br>2.0M 90° Sensors<br>2.5M 90° Sensors<br>2-Port Relay Valve<br>2.0M Relay Valve Cable<br>Warning Lamp Kit<br>Misc. Hardware & Labels | -               |

## ITCM FFABS Valve Kits New or Replacement Installation

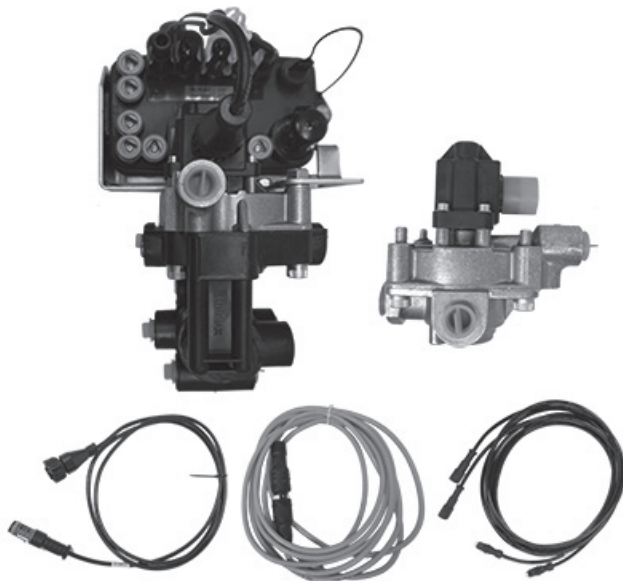

AQ965004 Shown

### Features:

- 2S/1M, 2S/2M, 4S/2M and 4S/3M ABS configurations
- Communication support includes CAN and PLC
- Patented FFABS Valve with integral Spring Brake Control function (additional valve required for 2M and 3M)
- Expanded Diagnostics and Fleet+

### Specifications:

- ECU Design: ITCM ECU will support 1M, 2M and 3M applications
- Auxiliary: Up to six auxiliary plug in options
- CAN: Controller Area Network - SAE J1939 and ISO 11898

### Notes:

- 1) ITCM includes expanded diagnostics.
- 2) Kit content varies see chart below for details.
- 3) Most ABS maintenance involves Wheel-end Sensors. Haldex recommends that Wheel-end Sensors be replaced when replacing or upgrading the ABS System.

| Service Part No. | Product Description                            | ECU/Valve OEM Part No. | Valve Specifications                                    | Kit Contents other than Valve/ECU Assemblies   | OEM Part Number |
|------------------|--|------------------------|---|--|-----------------|
| AQ965102         | ITCM FFABS Valve A7                            | N9004BA                | 4-Port FFABS (Spring Brake Priority)                    | Valve and ECU assembly only  | N4306JB         |
| AQ965103         | ITCM FFABS Valve A7                            | N9004CA                | 4-Port FFABS (Service Brake Priority)                   | Valve and ECU assembly only  | N4306KB         |
| AQ965105         | ITCM FFABS Valve A7                            | N9004BB                | 2-Port FFABS (Spring Brake Priority)                    | Valve and ECU assembly only  | N4306LB         |
| AQ965001         | ITCM FFABS Valve Kit, A7 for Tri-Axle, 4S/2M   | N9004BA                | 4-Port FFABS (Spring Brake Priority); 2-Port ABS Relay  | 6.0M Power Cord Extension<br>2.0M Relay Valve Cable<br>1.5M & 2.0M Sensor Ext.<br>Second Relay Valve (2-Port)<br>Hose Clips, Cable Grips | N4306JB         |
| AQ965004         | ITCM FFABS Valve Kit A7 for Tandem Axle, 4S/2M | N9004BB                | 2-Port FFABS (Spring Brake Priority), 2-Port ABS Relay  | 6.0M Power Cord Extension<br>2.0M Relay Valve Cable<br>1.5M & 2.5M Sensor Ext.<br>Second Relay Valve (2-Port)<br>Hose Clips, Cable Grips | N4306LB         |
| AQ965005         | ITCM FFABS Valve Kit A7 for Tri-Axles, 4S/2M   | N9004CA                | 4-Port FFABS (Service Brake Priority); 2-Port ABS Relay | 6.0M Power Cord Extension<br>2.0M Relay Valve Cable<br>1.5M & 2.5M Sensor Ext.<br>Second Relay Valve (2-Port)<br>Hose Clips, Cable Grips | N4306KB         |
| AQ965006         | ITCM FFABS Valve Kit A7 for Tandem Axle, 4S/2M | N9004CB                | 2-Port FFABS (Service Brake Priority); 2-Port ABS Relay | 6.0M Power Cord Extension<br>2.0M Relay Valve Cable<br>1.5M & 2.5M Sensor Ext.<br>Second Relay Valve (2-Port)<br>Hose Clips, Cable Grips | N4306MB         |

**ITCM Relay Valve Kits  
New or Replacement Installation**

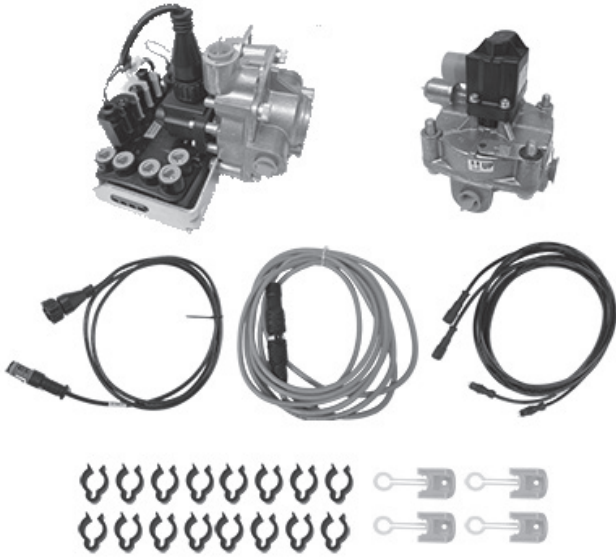

AQ965002 Shown

**Features:**

- 2S/1M, 2S/2M, 4S/2M and 4S/3M ABS configurations
- Communication support includes CAN and PLC
- For non-steer axles. Additional valve required for 2M and 3M.)
- Expanded Diagnostics and Fleet+

**Specifications:**

- ECU Design: ITCM ECU will support 1M, 2M and 3M applications
- Auxiliary: Up to six auxiliary plug in options
- CAN: Controller Area Network - SAE J1939 and ISO 11898

**Notes:**

- 1) ITCM includes expanded diagnostics.
- 2) Kit content varies see chart below for details.
- 3) Most ABS maintenance involves Wheel-end Sensors. Haldex recommends that Wheel-end Sensors be replaced when replacing or upgrading the ABS System.

| Service Part No. | Product Description                           | ECU/Valve OEM Part No. | Valve Specifications                                | Kit Contents other than Valve/ECU Assemblies   | OEM Part Number |
|------------------|---|------------------------|---|--|-----------------|
| AQ965100         | ITCM Relay Valve A7                           | N9004AA                | 6-Port Reservoir Mount                              | Valve and ECU assembly only  | N4306KB         |
| AQ965101         | ITCM Relay Valve A7                           | N9004AB                | 4-Port Reservoir Mount                              | Valve and ECU assembly only  | N4306MB         |
| AQ965104         | ITCM Relay Valve A7                           | N9004C                 | 2-Port Reservoir Mount                              | Valve and ECU assembly only  | N4306JB         |
| AQ965002         | ITCM Relay Valve Kit A7 for TandemAxle, 4S/2M | N9004C                 | Two 2-Port ABS Relay Reservoir Mount                | 6.0M Power Cord Extension<br>2.0M Relay Valve Cable<br>1.5M & 2.0M Sensor Ext.<br>Second Relay Valve (2-Port)<br>Hose Clips, Cable Grips | N4306JB         |
| AQ965003         | ITCM Relay Valve Kit A7 for Tri-Axle, 4S/2M   | N9004AA                | One 6-Port and One 2-Port ABS Relay Reservoir Mount | 6.0M Power Cord Extension<br>2.0M Relay Valve Cable<br>2.0M & 3.0M Sensor Ext.<br>Second Relay Valve (2-Port)<br>Hose Clips, Cable Grips | N4306LB         |

## ABS ECUs Upgrade Kits



AQ964111 Shown

### Features:

- Wheel-speed sensor and trailer power cord connect directly to ECU - no intermediate cables required
- Single fastener design assures easy serviceability
- Potted ECU enclosure provides excellent protection from the environment

### Specifications:

PLC Select 1M      Available to upgrade earlier  
and 2M Kits:      generation ECU platforms

### Notes:

- 1) Upgrade to new technology PLC Select 1M or 2M (see below for details).
- 2) Most ABS maintenance involves Wheel-end Sensors. Haldex recommends that Wheel-end Sensors be replaced when replacing or upgrading the ABS System.

| Service Part No. | Product Description  | ECU Design    | Kit Contents  | OEM Part Number |
|------------------|--|---------------|---|-----------------|
| AQ960502         | ECU Upgrade Kit<br>2S/1M A8 for Single Axle<br>and Dollie Applications | PLC Select    | 2.0M Power Cord Extension<br>3.0M Sensor Extensions<br>PLC Select ECU and Bracket<br>Power Cord End Kit                         | SN2605B         |
| AQ964110         | ECU Upgrade Kit<br>2S/1M A7 for Tandem<br>and Multiple Applications    | PLC Select    | 1.0M Power Cord Extension<br>0.5M Sensor Extensions<br>PLC Select ECU and Bracket   | SN2641TC        |
| AQ964111         | ECU Upgrade Kit<br>4S/2M for Multi-Axle<br>Applications                | 2M PLC Select | 2.0M Power Cord Extension<br>1.0M Sensor Extensions<br>PLC Select 2M ECU and Bracket<br>Power Cord End Kit<br>Valve Relay Cable | SN2632AA        |

### ABS ECUs

#### PLC Select 1M and 2M



AL919339 Shown

#### Features:

- Wheel-speed sensor and trailer power connect directly to ECU - no intermediate cables required
- Single fastener design assures easy serviceability
- Potted ECU enclosure provides excellent protection from the environment

#### Specifications:

PLS Select 1M: Supports all 2S/1M applications

PLC Select 2M: Supports all 4S/2M (or 2S/2M) applications

#### Notes:

- 1) PLC Select 1M and 2M Kits are available to upgrade earlier generation ECU platforms.
- 2) Post October 2009 Service Part Numbers incorporate DIN Style Solenoid Cable.
- 3) If replacing Pre-October 2009 ECU and replacing Valve Solenoid; use AL919347 Adapter Cable.

| Service Part No. | Product Description               | ECU Specification | ECU Dimensions  | Application                  | OEM Part Number |
|------------------|-----------------------------------|-------------------|---|------------------------------|-----------------|
| AL919336         | PLC Select Plus ECU 2S/1M         | DIN 12V, SLH-A7   | 4 1/4" Height x 8" Width                                  | Multi-Axle                   | 202028BC        |
| AL919338         | PLC Select 1M ECU 2S/1M           | DIN 12V, SLH-A7   | 4 1/4" Height x 5 1/2" Width                              | Multi-Axle (non-steer axles) | 201200BA        |
| AL919339         | PLC Select 1M ECU 2S/1M           | DIN 12V, SLH-A8   | 4 1/4" Height x 5 1/2" Width                              | Dollies and single axle      | 201200BB        |
| AL919340         | PLC Select 1M ECU 2S/1M           | DIN 12V, SLH-A7   | 4 1/4" Height x 5 1/2" Width with .675MM Valve Cable Lead | Multi-Axle (non-steer axles) | 201200BC        |
| AL919341         | PLC Select 1M ECU 2S/1M           | DIN 12V, SLH-A8   | 4 1/4" Height x 5 1/2" Width with .675MM Valve Cable Lead | Dollies and single axle      | 201200BD        |
| AL919342         | PLC Select 2M ECU 2S/2M and 4S/2M | DIN 12V, SLH-A7   | 4 1/4" Height x 8" Width                                  | Multi-Axle                   | 202028AB        |

## ABS ECUs Intelligent Trailer Control Module (ITCM)



AL919353 Shown

### Features:

- PLC Select Low/High technology, 12V power
- Self-configurable and flash upgradable
- 2S/1M, 2S/2M, 4S/2M and 4S/3M ABS configurations
- Communication support includes CAN and PLC
- Single fastener design assures easy serviceability
- Potted ECU enclosure provides excellent protection from the environment
- Expanded Diagnostics and Fleet+

### Specifications:

- Dimensions: 4 1/2" Height x 8" Wide
- Applications: ITCM ECU supports 1M, 2M and 3M
- Auxiliary: Up to six auxiliary plug in options
- Communication: Power Line Carrier (PLC)  
Trailer 7-Way  
Controller Area Network (CAN)  
SAE J1939 and ISO 11898

### Notes:

- 1) Upgrade any Haldex ABS platform.
- 2) Expanded Diagnostics platform available.
- 3) Bracket sold separately, use Part Number A920813.

| Service Part No. | Product Description | ECU Specification | Application             | Notes                       | OEM Part Number |
|------------------|---------------------|-------------------|-------------------------|-----------------------------|-----------------|
| AL919348         | ECU Only            | DIN 12V, SLH-A7   | Multi-Axle              | -                           | 201200CA        |
| AL919349         | ECU Only            | DIN 12V, SLH-A8   | Dollies and single axle | -                           | 201200CB        |
| AL919350         | ECU Only            | DIN 12V, SLH-A7   | Multi-Axle              | .675MM Valve Cable Included | 201200CC        |
| AL919351         | ECU Only            | DIN 12V, SLH-A8   | Dollies and single axle | .675MM Valve Cable Included | 201200CD        |
| AL919352         | ECU Only            | DIN 12V, SLH-A8   | Dollies and single axle | With BMS-3                  | 201200DA        |
| AL919353         | ECU and Bracket     | DIN 12V, SLH-A7   | Multi-Axle              | Bracket Included            | SN2900KA        |
| AL919354         | ECU and Bracket     | DIN 12V, SHL-A8   | Dollies and single axle | Bracket Included            | SN2900KB        |