



Single Groove Sheaves for "4L" or "A" Belts and "5L" or "B" Belts

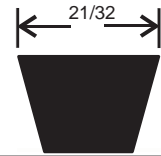
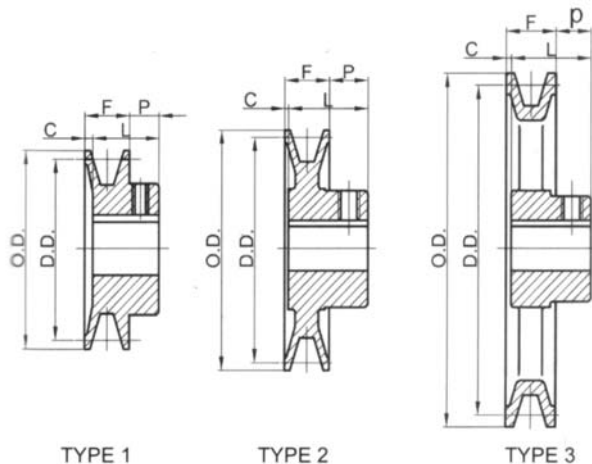

Table No.1 Stock Sizes—Finished Bore

| Part No. | DIAMETERS | | | Type | STOCK BORES MARKED "X" | | | | | | | | | | | DIMENSIONS | | | | Wt. Lbs. |
|----------|-----------|-----------|-----------|------|------------------------|------|------|------|--------|----|--------|---------|--------|--------|---------|------------|--------|-------|------|----------|
| | Out side | Datum "A" | Datum "B" | | 1/2" | 5/8" | 3/4" | 7/8" | 15/16" | 1" | 1 1/8" | 1 3/16" | 1 1/4" | 1 3/8" | 1 7/16" | F | L | P | C | |
| ▲BK24 | 2.40" | 1.80" | 2.20" | 1 | x | x | x | — | — | — | — | — | — | — | 13/16 | 1 1/16" | 13/32" | 5/32" | .4 | |
| ▲BK25 | 2.50 | 1.90 | 2.30 | 1 | x | x | x | x | — | — | — | — | — | — | 13/16 | 1 1/16 | 13/32 | 5/32 | .5 | |
| ▲BK26 | 2.60 | 2.00 | 2.40 | 1 | x | x | x | x | — | — | — | — | — | — | 13/16 | 1 1/16 | 13/32 | 5/32 | .6 | |
| ▲BK27 | 2.70 | 2.10 | 2.50 | 2 | x | x | x | x | — | — | — | — | — | — | 13/16 | 1 1/16 | 13/32 | 5/32 | .6 | |
| ▲BK28 | 2.95 | 2.20 | 2.60 | 2 | x | x | x | x | — | — | — | — | — | — | 13/16 | 1 1/16 | 13/32 | 5/32 | .8 | |
| ▲BK30 | 3.15 | 2.40 | 2.80 | 2 | x | x | x | x | — | — | — | — | — | — | 13/16 | 1 1/16 | 13/32 | 5/32 | .8 | |
| ▲BK32 | 3.35 | 2.60 | 3.00 | 2 | x | x | x | x | — | — | — | — | — | — | 13/16 | 1 1/16 | 13/32 | 5/32 | .8 | |
| BK34 | 3.55 | 2.80 | 3.20 | 2 | x | x | x | x | — | x | x | — | — | — | 7/8 | 1 5/32 | 13/32 | 1/8 | 1.3 | |
| BK36 | 3.75 | 3.00 | 3.40 | 2 | x | x | x | x | — | x | x | — | — | — | 7/8 | 1 5/32 | 13/32 | 1/8 | 1.5 | |
| BK40 | 3.95 | 3.20 | 3.60 | 2 | x | x | x | x | — | x | x | — | — | — | 7/8 | 1 5/32 | 13/32 | 1/8 | 1.5 | |
| BK45 | 4.25 | 3.50 | 3.90 | 2 | x | x | x | x | — | x | x | — | — | — | 7/8 | 1 5/32 | 13/32 | 1/8 | 1.8 | |
| BK47 | 4.45 | 3.70 | 4.10 | 2 | x | x | x | x | — | x | x | — | — | — | 7/8 | 1 5/32 | 13/32 | 1/8 | 1.9 | |
| BK50 | 4.75 | 4.00 | 4.40 | 3 | x | x | x | x | x | x | x | — | — | — | 7/8 | 1 5/32 | 13/32 | 1/8 | 2.0 | |
| BK52 | 4.95 | 4.20 | 4.60 | 3 | x | x | x | x | — | x | x | — | — | — | 7/8 | 1 5/32 | 13/32 | 1/8 | 2.0 | |
| BK55 | 5.25 | 4.50 | 4.90 | 3 | x | x | x | x | — | x | x | x | — | — | 7/8 | 1 5/32 | 13/32 | 1/8 | 2.2 | |
| BK57 | 5.45 | 4.70 | 5.10 | 3 | — | x | x | x | x | x | x | — | — | — | 7/8 | 1 5/32 | 13/32 | 1/8 | 2.3 | |
| BK60 | 5.75 | 5.00 | 5.40 | 3 | x | x | x | x | — | x | x | x | — | — | 7/8 | 1 5/32 | 13/32 | 1/8 | 2.3 | |
| BK62 | 5.95 | 5.20 | 5.60 | 3 | x | x | x | x | x | x | x | — | — | — | 7/8 | 1 5/32 | 13/32 | 1/8 | 2.4 | |
| BK65 | 6.25 | 5.50 | 5.90 | 3 | — | x | x | x | — | x | x | — | — | — | 7/8 | 1 5/32 | 13/32 | 1/8 | 2.7 | |
| BK67 | 6.45 | 5.70 | 6.10 | 3 | — | x | x | x | — | x | x | — | — | — | 7/8 | 1 5/32 | 13/32 | 1/8 | 2.8 | |
| BK70 | 6.75 | 6.00 | 6.40 | 3 | — | x | x | — | x | x | x | — | — | x | 7/8 | 1 15/32 | 21/32★ | 1/16★ | 3.3 | |
| BK72 | 6.95 | 6.20 | 6.60 | 3 | — | — | x | — | — | x | x | — | — | x | 7/8 | 1 15/32 | 21/32 | 1/16 | 3.9 | |
| BK75 | 7.25 | 6.50 | 6.90 | 3 | — | — | x | — | — | x | x | — | — | x | 7/8 | 1 15/32 | 21/32 | 1/16 | 3.9 | |
| BK77 | 7.45 | 6.70 | 7.10 | 3 | — | — | x | — | — | x | x | — | — | x | 7/8 | 1 15/32 | 21/32 | 1/16 | 4.1 | |
| BK80 | 7.75 | 7.00 | 7.40 | 3 | — | x | x | x | — | x | x | x | — | x | 7/8 | 1 15/32 | 21/32 | 1/16 | 4.4 | |
| BK85 | 8.25 | 7.50 | 7.90 | 3 | — | — | x | — | — | x | x | — | — | x | 7/8 | 1 15/32 | 21/32 | 1/16 | 5.0 | |
| BK90 | 8.75 | 8.00 | 8.40 | 3 | — | — | x | x | x | x | x | — | — | x | 7/8 | 1 15/32 | 21/32 | 1/16 | 5.0 | |
| BK95 | 9.25 | 8.50 | 8.90 | 3 | — | — | x | — | — | x | x | — | — | x | 7/8 | 1 15/32 | 21/32 | 1/16 | 5.4 | |
| BK100 | 9.75 | 9.00 | 9.40 | 3 | — | — | x | x | x | x | x | — | — | x | 7/8 | 1 15/32 | 21/32 | 1/16 | 5.6 | |
| BK105 | 10.25 | 9.50 | 9.90 | 3 | — | — | — | — | — | x | — | — | — | x | 7/8 | 1 15/32 | 21/32 | 1/16 | 5.8 | |
| BK110 | 10.75 | 10.00 | 10.40 | 3 | — | — | x | — | — | x | x | x | — | x | 7/8 | 1 15/32 | 21/32 | 1/16 | 6.4 | |
| BK115 | 11.25 | 10.50 | 10.90 | 3 | — | — | — | — | — | x | — | — | — | x | 7/8 | 1 15/32 | 21/32 | 1/16 | 6.9 | |
| BK120 | 11.75 | 11.00 | 11.40 | 3 | — | — | x | — | — | x | — | x | — | x | 7/8 | 1 15/32 | 21/32 | 1/16 | 7.4 | |
| BK130 | 12.75 | 12.00 | 12.40 | 3 | — | — | x | — | — | x | x | x | — | x | 7/8 | 1 15/32 | 21/32 | 1/16 | 8.4 | |
| BK140 | 13.75 | 13.00 | 13.40 | 3 | — | — | x | — | — | x | — | x | — | x | 7/8 | 1 15/32 | 21/32 | 1/16 | 9.4 | |
| BK160 | 15.75 | 15.00 | 15.40 | 3 | — | — | — | — | — | x | x | x | — | x | 7/8 | 1 15/32 | 21/32 | 1/16 | 11.4 | |
| BK190 | 18.75 | 18.00 | 18.40 | 3 | — | — | — | — | — | x | — | x | — | x | 7/8 | 1 15/32 | 21/32 | 1/16 | 13.4 | |

★P=13/32" and C=1/8" for 1" Bore and Smaller

▲NOTE—DO NOT USE THESE "BK" SHEAVES WITH "B" NOTCHED BELT RATINGS.



◆ ◆
 HOLLOW HEAD SETSCREWS
 ◆ ◆
 STATICALLY BALANCED
 ◆ ◆

Standard Keyseats Table No.2

| Bore Range | Keyseat |
|----------------|-------------|
| 1/2" | None |
| 5/8 to 7/8 | 3/16"x3/32' |
| 15/16 to 1 1/4 | 1/4x1/8 |
| 1 7/16 | 3/8x3/16 |

Single Groove Sheaves for "4L" or "A" Belts and "5L" or "B" Belts

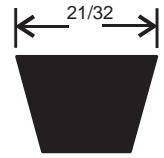
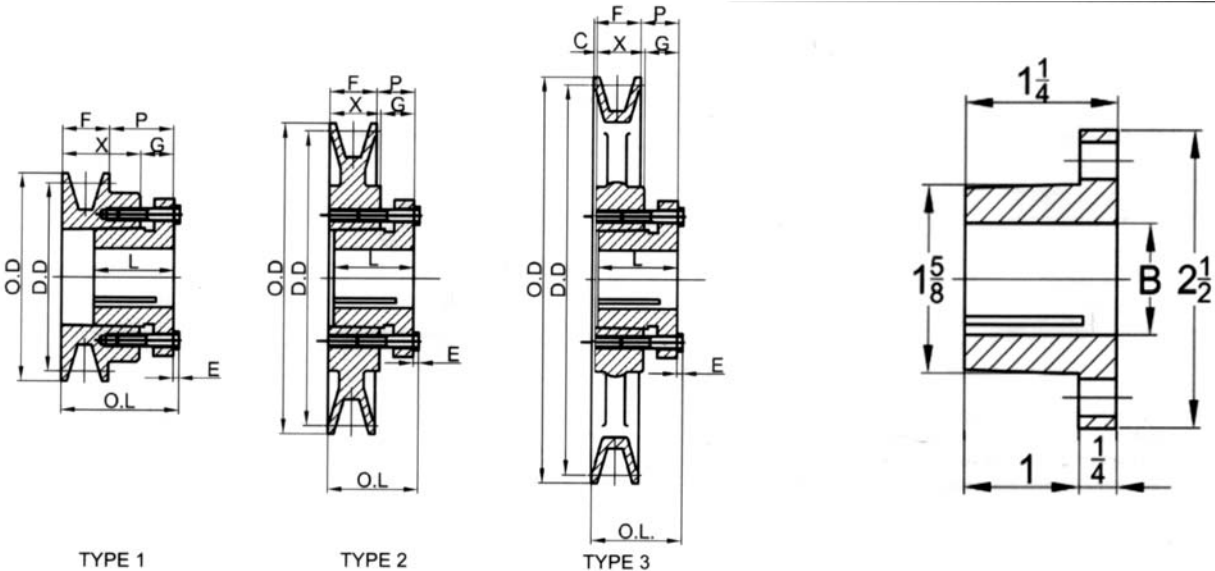
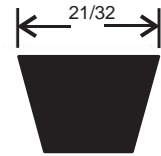

Table No.1 Stock Sizes—Finished Bore

| Part No. | DIAMETERS | | | Type | DIMENSIONS | | | | | | | | Wt. Less Bus |
|----------|-----------|-----------|-----------|------|------------|------|--------|------|-------|---------|-------|-------|--------------|
| | O.D. | Datum "A" | Datum "B" | | O.L. | F | L | P | C | X | G | E | |
| BK30H | 3.15" | 2.40" | 2.80" | 1 | 1 15/16" | 7/8" | 1 1/4" | 7/8" | — | 1 5/16" | 7/16" | 3/16" | 1.2 |
| BK32H | 3.35 | 2.60 | 3.00 | 1 | 1 15/16 | 7/8 | 1 1/4 | 7/8 | — | 1 5/16 | 7/16 | 3/16 | 1.40 |
| BK34H | 3.55 | 2.80 | 3.20 | 1 | 1 15/16 | 7/8 | 1 1/4 | 7/8 | — | 1 5/16 | 7/16 | 3/16 | 1.60 |
| BK36H | 3.75 | 3.00 | 3.40 | 2 | 1 1/2 | 7/8 | 1 1/4 | 7/16 | — | 7/8 | 7/16 | 3/16 | 1.20 |
| BK40H | 3.95 | 3.20 | 3.60 | 2 | 1 1/2 | 7/8 | 1 1/4 | 7/16 | — | 7/8 | 7/16 | 3/16 | 1.40 |
| BK45H | 4.25 | 3.50 | 3.90 | 2 | 1 1/2 | 7/8 | 1 1/4 | 7/16 | — | 7/8 | 7/16 | 3/16 | 1.80 |
| BK47H | 4.45 | 3.70 | 4.10 | 2 | 1 1/2 | 7/8 | 1 1/4 | 7/16 | — | 7/8 | 7/16 | 3/16 | 2.20 |
| BK50H | 4.75 | 4.00 | 4.40 | 2 | 1 1/2 | 7/8 | 1 1/4 | 7/16 | — | 7/8 | 7/16 | 3/16 | 2.00 |
| BK52H | 4.95 | 4.20 | 4.60 | 2 | 1 1/2 | 7/8 | 1 1/4 | 7/16 | — | 7/8 | 7/16 | 3/16 | 2.10 |
| BK55H | 5.25 | 4.50 | 4.90 | 2 | 1 1/2 | 7/8 | 1 1/4 | 7/16 | — | 7/8 | 7/16 | 3/16 | 2.70 |
| BK57H | 5.45 | 4.70 | 5.10 | 2 | 1 1/2 | 7/8 | 1 1/4 | 7/16 | — | 7/8 | 7/16 | 3/16 | 2.70 |
| BK60H | 5.75 | 5.00 | 5.40 | 2 | 1 1/2 | 7/8 | 1 1/4 | 7/16 | — | 7/8 | 7/16 | 3/16 | 2.50 |
| BK62H | 5.95 | 5.20 | 5.60 | 2 | 1 1/2 | 7/8 | 1 1/4 | 7/16 | — | 7/8 | 7/16 | 3/16 | 2.60 |
| BK65H | 6.25 | 5.50 | 5.90 | 2 | 1 1/2 | 7/8 | 1 1/4 | 7/16 | — | 7/8 | 7/16 | 3/16 | 2.80 |
| BK67H | 6.45 | 5.70 | 6.10 | 2 | 1 1/2 | 7/8 | 1 1/4 | 7/16 | — | 7/8 | 7/16 | 3/16 | 2.90 |
| BK70H | 6.75 | 6.00 | 6.40 | 3 | 1 9/16 | 7/8 | 1 1/4 | 1/2 | 1/16" | 7/8 | 7/16 | 3/16 | 2.80 |
| BK72H | 6.95 | 6.20 | 6.60 | 3 | 1 9/16 | 7/8 | 1 1/4 | 1/2 | 1/16" | 7/8 | 7/16 | 3/16 | 3.10 |
| BK75H | 7.25 | 6.50 | 6.90 | 3 | 1 9/16 | 7/8 | 1 1/4 | 1/2 | 1/16" | 7/8 | 7/16 | 3/16 | 3.30 |
| BK77H | 7.45 | 6.70 | 7.10 | 3 | 1 9/16 | 7/8 | 1 1/4 | 1/2 | 1/16" | 7/8 | 7/16 | 3/16 | 3.80 |
| BK80H | 7.75 | 7.00 | 7.40 | 3 | 1 9/16 | 7/8 | 1 1/4 | 1/2 | 1/16" | 7/8 | 7/16 | 3/16 | 3.40 |
| BK85H | 8.25 | 7.50 | 7.90 | 3 | 1 9/16 | 7/8 | 1 1/4 | 1/2 | 1/16" | 7/8 | 7/16 | 3/16 | 3.80 |
| BK90H | 8.75 | 8.00 | 8.40 | 3 | 1 9/16 | 7/8 | 1 1/4 | 1/2 | 1/16" | 7/8 | 7/16 | 3/16 | 4.30 |
| BK95H | 9.25 | 8.50 | 8.90 | 3 | 1 9/16 | 7/8 | 1 1/4 | 1/2 | 1/16" | 7/8 | 7/16 | 3/16 | 5.00 |
| BK100H | 9.75 | 9.00 | 9.40 | 3 | 1 9/16 | 7/8 | 1 1/4 | 1/2 | 1/16" | 7/8 | 7/16 | 3/16 | 5.20 |
| BK105H | 10.25 | 9.50 | 9.90 | 3 | 1 9/16 | 7/8 | 1 1/4 | 1/2 | 1/16" | 7/8 | 7/16 | 3/16 | 5.50 |
| BK110H | 10.75 | 10.00 | 10.40 | 3 | 1 9/16 | 7/8 | 1 1/4 | 1/2 | 1/16" | 7/8 | 7/16 | 3/16 | 6.00 |
| BK115H | 11.25 | 10.50 | 10.90 | 3 | 1 9/16 | 7/8 | 1 1/4 | 1/2 | 1/16" | 7/8 | 7/16 | 3/16 | 6.40 |
| BK120H | 11.75 | 11.00 | 11.40 | 3 | 1 9/16 | 7/8 | 1 1/4 | 1/2 | 1/16" | 7/8 | 7/16 | 3/16 | 6.90 |
| BK130H | 12.75 | 12.00 | 12.40 | 3 | 1 9/16 | 7/8 | 1 1/4 | 1/2 | 1/16" | 7/8 | 7/16 | 3/16 | 6.90 |
| BK140H | 13.75 | 13.00 | 13.40 | 3 | 1 9/16 | 7/8 | 1 1/4 | 1/2 | 1/16" | 7/8 | 7/16 | 3/16 | 8.50 |
| BK150H | 14.75 | 14.00 | 14.40 | 3 | 1 9/16 | 7/8 | 1 1/4 | 1/2 | 1/16" | 7/8 | 7/16 | 3/16 | 9.50 |
| BK160H | 15.75 | 15.00 | 15.40 | 3 | 1 9/16 | 7/8 | 1 1/4 | 1/2 | 1/16" | 7/8 | 7/16 | 3/16 | 9.80 |
| BK190H | 18.75 | 18.00 | 18.40 | 3 | 1 9/16 | 7/8 | 1 1/4 | 1/2 | 1/16" | 7/8 | 7/16 | 3/16 | 12.80 |





Two Groove Sheaves for "4L" or "A" Belts and "5L" or "B" Belts

Table No.1 Stock Sizes—Finished Bore

| Part No. | DIAMETERS | | | Type | STOCK BORES MARKED "X" | | | | | | | | | DIMENSIONS | | | | Wt. Lbs. |
|----------|-----------|-----------|-----------|------|------------------------|------|------|------|----|--------|---------|--------|---------|------------|--------|------|------|----------|
| | Out side | Datum "A" | Datum "B" | | 1/2" | 5/8" | 3/4" | 7/8" | 1" | 1 1/8" | 1 3/16" | 1 3/8" | 1 7/16" | F | L | P | C | |
| 2BK25 | 2.50" | 1.90" | 2.30" | 1 | x | x | x | x | — | — | — | — | 1 3/4" | 1 31/3 | 15/32" | 1/4" | 1.3 | |
| 2BK27 | 2.70 | 2.10 | 2.50 | 1 | x | x | x | x | x | — | — | — | 1 3/4 | 1 31/3 | 15/32 | 1/4 | 1.6 | |
| 2BK28 | 2.95 | 2.20 | 2.60 | 1 | x | x | x | x | x | — | — | — | 1 3/4 | 1 31/3 | 15/32 | 1/4 | 1.9 | |
| 2BK30 | 3.15 | 2.40 | 2.80 | 1 | x | x | x | x | x | — | — | — | 1 3/4 | 1 31/3 | 15/32 | 1/4 | 2.3 | |
| 2BK32 | 3.35 | 2.60 | 3.00 | 1 | — | x | — | x | x | — | — | — | 1 3/4 | 1 31/3 | 15/32 | 1/4 | 2.6 | |
| 2BK34 | 3.55 | 2.80 | 3.20 | 1 | — | x | x | x | x | — | — | — | 1 3/4 | 1 31/3 | 15/32 | 1/4 | 2.8 | |
| 2BK36 | 3.75 | 3.00 | 3.40 | 1 | — | — | x | x | x | — | x | — | 1 3/4 | 1 31/3 | 15/32 | 1/4 | 3.3 | |
| 2BK40 | 3.95 | 3.20 | 3.60 | 2 | — | x | x | x | x | — | — | — | 1 3/4 | 1 15/3 | 15/32 | 3/4 | 3.3 | |
| 2BK45 | 4.25 | 3.50 | 3.90 | 2 | — | — | — | — | x | x | — | x | 1 3/4 | 1 15/3 | 15/32 | 3/4 | 3.3 | |
| 2BK47 | 4.45 | 3.70 | 4.10 | 2 | — | — | — | x | x | — | — | — | 1 3/4 | 1 15/3 | 15/32 | 3/4 | 3.7 | |
| 2BK50 | 4.75 | 4.00 | 4.40 | 2 | — | — | x | — | x | x | — | x | 1 3/4 | 1 15/3 | 15/32 | 3/4 | 4.1 | |
| 2BK52 | 4.95 | 4.20 | 4.60 | 2 | — | — | — | x | x | x | — | x | 1 3/4 | 1 15/3 | 15/32 | 3/4 | 4.5 | |
| 2BK55 | 5.25 | 4.50 | 4.90 | 2 | — | — | — | — | — | x | — | x | 1 3/4 | 1 15/3 | 15/32 | 3/4 | 4.5 | |
| 2BK57 | 5.45 | 4.70 | 5.10 | 2 | — | — | — | — | x | x | — | x | 1 3/4 | 1 15/3 | 15/32 | 3/4 | 5.1 | |
| 2BK60 | 5.75 | 5.00 | 5.40 | 3 | — | — | x | x | x | x | — | x | 1 3/4 | 1 15/3 | 15/32 | 3/4 | 4.9 | |
| 2BK62 | 5.95 | 5.20 | 5.60 | 3 | — | — | — | — | x | x | — | x | 1 3/4 | 1 15/3 | 15/32 | 3/4 | 4.8 | |
| 2BK65 | 6.25 | 5.50 | 5.90 | 3 | — | — | — | — | x | x | — | x | 1 3/4 | 1 15/3 | 15/32 | 3/4 | 5.0 | |
| 2BK67 | 6.45 | 5.70 | 6.10 | 3 | — | — | — | — | x | x | — | x | 1 3/4 | 1 15/3 | 15/32 | 3/4 | 5.0 | |
| 2BK70 | 6.75 | 6.00 | 6.40 | 3 | — | — | x | — | x | x | — | x | 1 3/4 | 1 19/3 | 11/32 | 1/2 | 6.6 | |
| 2BK80 | 7.75 | 7.00 | 7.40 | 3 | — | — | x | — | x | x | — | x | 1 3/4 | 1 19/3 | 11/32 | 1/2 | 7.2 | |
| 2BK90 | 8.75 | 8.00 | 8.40 | 3 | — | — | x | — | x | x | — | x | 1 3/4 | 1 19/3 | 11/32 | 1/2 | 8.4 | |
| 2BK100 | 9.75 | 9.00 | 9.40 | 3 | — | — | x | — | x | — | — | x | 1 3/4 | 1 19/3 | 11/32 | 1/2 | 9.4 | |
| 2BK110 | 10.75 | 10.00 | 10.40 | 3 | — | — | — | — | x | — | x | — | 1 3/4 | 1 19/3 | 11/32 | 1/2 | 10.4 | |
| 2BK120 | 11.75 | 11.00 | 11.40 | 3 | — | — | — | — | x | — | x | — | 1 3/4 | 1 19/3 | 11/32 | 1/2 | 11.8 | |
| 2BK130 | 12.75 | 12.00 | 12.40 | 3 | — | — | — | — | x | — | x | — | 1 3/4 | 1 19/3 | 11/32 | 1/2 | 14.9 | |
| 2BK140 | 13.75 | 13.00 | 13.40 | 3 | — | — | — | — | x | — | — | x | 1 3/4 | 1 19/3 | 11/32 | 1/2 | 16.3 | |
| 2BK160 | 15.75 | 15.00 | 15.40 | 3 | — | — | — | — | x | — | x | — | 1 3/4 | 1 19/3 | 11/32 | 1/2 | 18.0 | |
| 2BK190 | 18.75 | 18.00 | 18.40 | 3 | — | — | — | — | — | — | x | — | 1 3/4 | 1 19/3 | 11/32 | 1/2 | 23.3 | |

Standard Keyseats

Table No.2

| Bore Range | Keyseat |
|-----------------|--------------|
| 1/2" | None |
| 5/8 to 7/8 | 3/16 x3/32 " |
| 15/16 to 1 3/16 | 1/4x1/8 |
| 1 3/8 | 5/16 x5/32 |
| 1 7/16 | 3/8x3/16 |

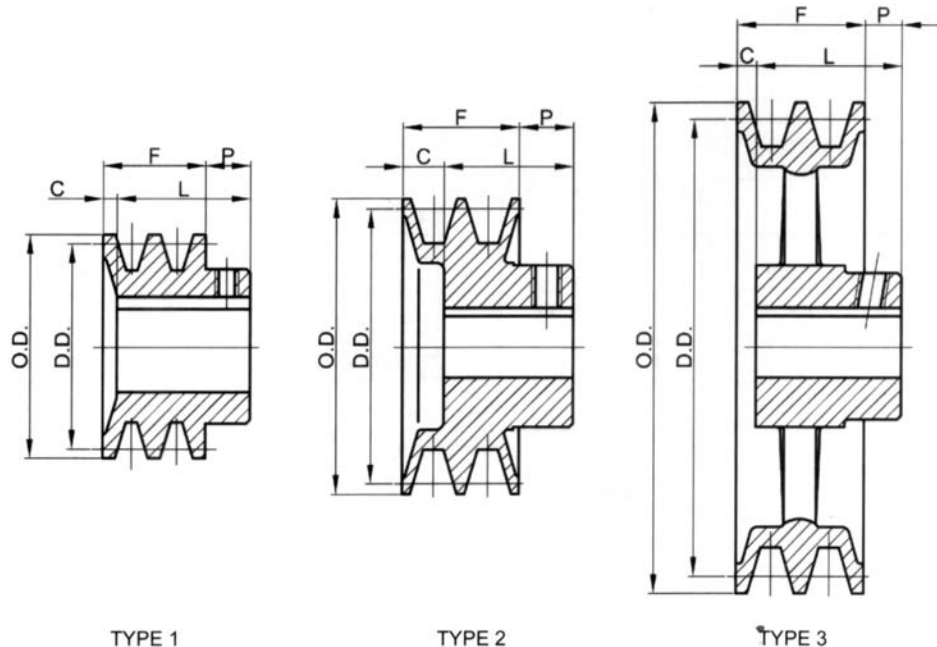

Two Groove Sheaves for "4L" or "A" Belts "4L" or "A" Belts

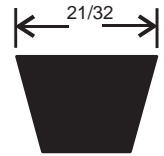
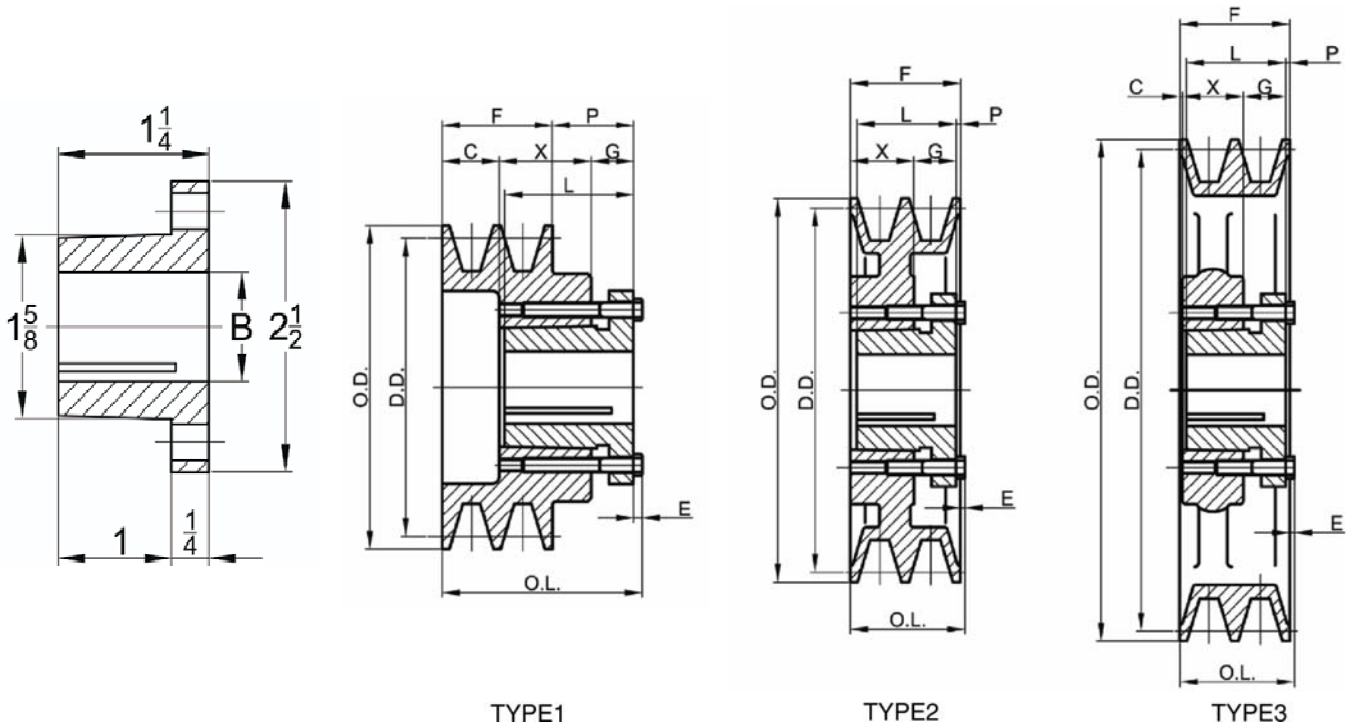

Table No.1

Stock Sizes—with Split Taper Bushings

| Part No. | DIAMETERS | | | Type | DIMENSIONS | | | | | | | | Wt. Less Bus |
|----------|-----------|-----------|-----------|------|------------|--------|--------|------|--------|------|-------|-------|--------------|
| | O.D. | Datum "A" | Datum "B" | | O.L. | F | L | P | C | X | G | E | |
| 2BK32H | 3.35" | 2.60" | 3.00" | 1 | 2 13/16" | 1 3/4" | 1 1/4" | 7/8" | 1 5/16 | 7/8" | 7/16" | 3/16" | 2.10 |
| 2BK34H | 3.55 | 2.80 | 3.20 | 1 | 2 13/16 | 1 3/4 | 1 1/4 | 7/8 | 1 5/16 | 7/8 | 7/16 | 3/16 | 2.40 |
| 2BK36H | 3.75 | 3.00 | 3.40 | 1 | 2 3/8 | 1 3/4 | 1 1/4 | 7/16 | 7/8 | 7/8 | 7/16 | 3/16 | 2.00 |
| 2BK40H | 3.95 | 3.20 | 3.60 | 1 | 2 3/8 | 1 3/4 | 1 1/4 | 7/16 | 7/8 | 7/8 | 7/16 | 3/16 | 2.40 |
| 2BK45H | 4.25 | 3.50 | 3.90 | 1 | 2 3/8 | 1 3/4 | 1 1/4 | 7/16 | 7/8 | 7/8 | 7/16 | 3/16 | 3.00 |
| 2BK47H | 4.45 | 3.70 | 4.10 | 2 | 1 3/4 | 1 3/4 | 1 1/4 | 7/16 | — | 7/8 | 7/16 | 3/16 | 2.80 |
| 2BK50H | 4.75 | 4.00 | 4.40 | 2 | 1 3/4 | 1 3/4 | 1 1/4 | 7/16 | — | 7/8 | 7/16 | 3/16 | 3.30 |
| 2BK52H | 4.95 | 4.20 | 4.60 | 2 | 1 3/4 | 1 3/4 | 1 1/4 | 7/16 | — | 7/8 | 7/16 | 3/16 | 3.60 |
| 2BK55H | 5.25 | 4.50 | 4.90 | 2 | 1 3/4 | 1 3/4 | 1 1/4 | 7/16 | — | 7/8 | 7/16 | 3/16 | 3.90 |
| 2BK57H | 5.45 | 4.70 | 5.10 | 2 | 1 3/4 | 1 3/4 | 1 1/4 | 7/16 | — | 7/8 | 7/16 | 3/16 | 4.30 |
| 2BK60H | 5.75 | 5.00 | 5.40 | 2 | 1 3/4 | 1 3/4 | 1 1/4 | 7/16 | — | 7/8 | 7/16 | 3/16 | 4.40 |
| 2BK62H | 5.95 | 5.20 | 5.60 | 2 | 1 3/4 | 1 3/4 | 1 1/4 | 7/16 | — | 7/8 | 7/16 | 3/16 | 4.50 |
| 2BK65H | 6.25 | 5.50 | 5.90 | 3 | 1 3/4 | 1 3/4 | 1 1/4 | 7/16 | 1/4 | 7/8 | 7/16 | 3/16 | 4.50 |
| 2BK67H | 6.45 | 5.70 | 6.10 | 3 | 1 3/4 | 1 3/4 | 1 1/4 | 7/16 | 1/4 | 7/8 | 7/16 | 3/16 | 5.00 |
| 2BK70H | 6.75 | 6.00 | 6.40 | 3 | 1 3/4 | 1 3/4 | 1 1/4 | 7/16 | 1/4 | 7/8 | 7/16 | 3/16 | 5.10 |
| 2BK80H | 7.75 | 7.00 | 7.40 | 3 | 1 3/4 | 1 3/4 | 1 1/4 | 7/16 | 1/4 | 7/8 | 7/16 | 3/16 | 6.40 |
| 2BK90H | 8.75 | 8.00 | 8.40 | 3 | 1 3/4 | 1 3/4 | 1 1/4 | 7/16 | 1/4 | 7/8 | 7/16 | 3/16 | 7.60 |
| 2BK100H | 9.75 | 9.00 | 9.40 | 3 | 1 3/4 | 1 3/4 | 1 1/4 | 7/16 | 1/4 | 7/8 | 7/16 | 3/16 | 8.40 |
| 2BK110H | 10.75 | 10.00 | 10.40 | 3 | 1 3/4 | 1 3/4 | 1 1/4 | 7/16 | 1/4 | 7/8 | 7/16 | 3/16 | 9.30 |
| 2BK120H | 11.75 | 11.00 | 11.40 | 3 | 1 3/4 | 1 3/4 | 1 1/4 | 7/16 | 1/4 | 7/8 | 7/16 | 3/16 | 11.00 |
| 2BK130H | 12.75 | 12.00 | 12.40 | 3 | 1 3/4 | 1 3/4 | 1 1/4 | 7/16 | 1/4 | 7/8 | 7/16 | 3/16 | 13.10 |
| 2BK140H | 13.75 | 13.00 | 13.40 | 3 | 1 3/4 | 1 3/4 | 1 1/4 | 7/16 | 1/4 | 7/8 | 7/16 | 3/16 | 14.80 |
| 2BK160H | 15.75 | 15.00 | 15.40 | 3 | 1 3/4 | 1 3/4 | 1 1/4 | 7/16 | 1/4 | 7/8 | 7/16 | 3/16 | 17.50 |
| 2BK190H | 18.75 | 18.00 | 18.40 | 3 | 1 3/4 | 1 3/4 | 1 1/4 | 7/16 | 1/4 | 7/8 | 7/16 | 3/16 | 21.50 |



Three Groove Sheaves

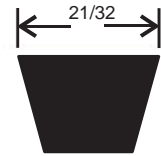

COMBINATION GROOVE

for "4L" or "A" Belts and "5L" or "B" Belts

Table No. 1 Stock Sizes-Finished Bore

| Part No. | DIAMETERS | | | Type | STOCK BORES MARKED "X" | | | | | | | Wt. Lbs. |
|----------|-----------|-----------|-----------|------|------------------------|------|----|--------|-------|------|-----|----------|
| | Outside | Datum "A" | Datum "B" | | 5/8" | 7/8" | 1" | 1 1/8" | F | L | P | |
| 3BK25 | 2.50" | 1.9" | 2.3" | 1 | x | x | | | 2 1/2 | 3" | 1/2 | 1.70 |
| 3BK27 | 2.70 | 2.10 | 2.50 | 1 | x | x | x | | 2 1/2 | 3.00 | 1/2 | 2.10 |
| 3BK28 | 2.95 | 2.20 | 2.60 | 1 | x | x | x | x | 2 1/2 | 3.00 | 1/2 | 2.50 |
| 3BK30 | 3.15 | 2.40 | 2.80 | 1 | | x | x | x | 2 1/2 | 3.00 | 1/2 | 3.00 |
| 3BK32 | 3.35 | 2.60 | 3.00 | 1 | | x | x | x | 2 1/2 | 3.00 | 1/2 | 3.40 |
| 3BK34 | 3.55 | 2.80 | 3.20 | 1 | | x | x | x | 2 1/2 | 3.00 | 1/2 | 3.80 |
| 3BK36 | 3.75 | 3.00 | 3.40 | 1 | | x | x | x | 2 1/2 | 3.00 | 1/2 | 4.30 |
| 3BK40 | 3.95 | 3.20 | 3.60 | 1 | | x | x | x | 2 1/2 | 3.00 | 1/2 | 4.70 |

Standard Keyseats

Table No.2

| Bore Range | Keyseats |
|------------------|-------------|
| 5/8" to 7/8" | 3/16"x3/32" |
| 15/16" to 1 1/8" | 1/4"x1/8" |

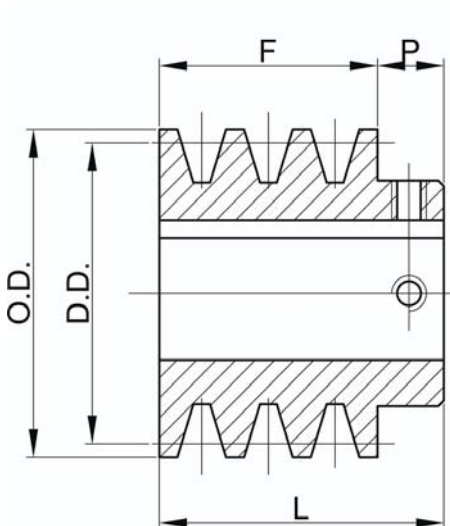

Close Grain Cast Iron

Accurately Machined

INDIVIDUALLY PACKGED

HOLLOW HEAD SETSCREWS PAINTED



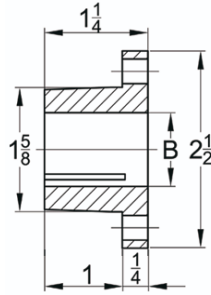

**Three Groove Sheaves
COMBINATION GROOVE**
for "4L" or "A" Belts and "5L" or "B" Belts

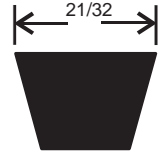
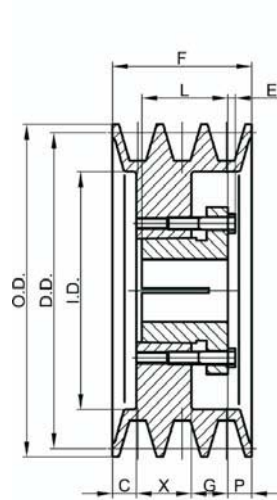

Table No.1

Stock Sizes - with Split Taper Bushings

| Part No. | DIAMETERS | | | | Type | DIMENSIONS | | | | | | | Wt. Less Bush |
|----------|-----------|-----------|-----------|---------|------|------------|--------|-------|--------|------|-------|-------|---------------|
| | Out side | Datum "A" | Datum "B" | Inside | | F | L | P | C | X | G | E | |
| 3BK45H | 4.25" | 3.5" | 3.9" | 2 5/8" | 2 | 2 1/2" | 1 1/4" | 1/2" | 11/16" | 7/8" | 7/16" | 3/16" | 3.90 |
| 3BK47H | 4.45 | 3.70 | 4.10 | 2 11/16 | 2 | 2 1/2 | 1 1/4 | 1/2 | 11/16 | 7/8 | 7/16 | 3/16 | 4.20 |
| 3BK50H | 4.75 | 4.00 | 4.40 | 3 | 2 | 2 1/2 | 1 1/4 | 1/2 | 11/16 | 7/8 | 7/16 | 3/16 | 4.40 |
| 3BK52H | 4.95 | 4.20 | 4.60 | 3 3/16 | 2 | 2 1/2 | 1 1/4 | 1/2 | 11/16 | 7/8 | 7/16 | 3/16 | 4.70 |
| 3BK55H | 5.25 | 4.50 | 4.90 | 3 1/2 | 2 | 2 1/2 | 1 1/4 | 1/2 | 11/16 | 7/8 | 7/16 | 3/16 | 5.10 |
| 3BK57H | 5.45 | 4.70 | 5.10 | 3 11/16 | 2 | 2 1/2 | 1 1/4 | 1/2 | 11/16 | 7/8 | 7/16 | 3/16 | 5.30 |
| 3BK60H | 5.75 | 5.00 | 5.40 | 4 | 3 | 2 1/2 | 1 1/4 | 1/2 | 11/16 | 7/8 | 7/16 | 3/16 | 5.60 |
| 3BK62H | 5.95 | 5.20 | 5.60 | 4 3/16 | 3 | 2 1/2 | 1 1/4 | 1/2 | 11/16 | 7/8 | 7/16 | 3/16 | 5.80 |
| 3BK65H | 6.25 | 5.50 | 5.90 | 4 1/2 | 3 | 2 1/2 | 1 1/4 | 29/32 | 9/32 | 7/8 | 7/16 | 3/16 | 5.80 |
| 3BK67H | 6.45 | 5.70 | 6.10 | 4 11/16 | 3 | 2 1/2 | 1 1/4 | 29/32 | 9/32 | 7/8 | 7/16 | 3/16 | 6.20 |
| 3BK70H | 6.75 | 6.00 | 6.40 | 5 | 3 | 2 1/2 | 1 1/4 | 29/32 | 9/32 | 7/8 | 7/16 | 3/16 | 6.60 |
| 3BK80H | 7.75 | 7.00 | 7.40 | 6 | 3 | 2 1/2 | 1 1/4 | 27/32 | 11/32 | 7/8 | 7/16 | 3/16 | 8.30 |
| 3BK90H | 8.75 | 8.00 | 8.40 | 7 | 3 | 2 1/2 | 1 1/4 | 27/32 | 11/32 | 7/8 | 7/16 | 3/16 | 9.80 |
| 3BK100H | 9.75 | 9.00 | 9.40 | 8 | 3 | 2 1/2 | 1 1/4 | 27/32 | 11/32 | 7/8 | 7/16 | 3/16 | 10.90 |
| 3BK110H | 10.75 | 10.00 | 10.40 | 9 | 3 | 2 1/2 | 1 1/4 | 27/32 | 11/32 | 7/8 | 7/16 | 3/16 | 12.10 |
| 3BK120H | 11.75 | 11.00 | 11.40 | 10 | 3 | 2 1/2 | 1 1/4 | 27/32 | 11/32 | 7/8 | 7/16 | 3/16 | 14.30 |
| 3BK130H | 12.75 | 12.00 | 12.40 | 11 | 3 | 2 1/2 | 1 1/4 | 25/32 | 13/32 | 7/8 | 7/16 | 3/16 | 16.20 |
| 3BK140H | 13.75 | 13.00 | 13.40 | 12 | 3 | 2 1/2 | 1 1/4 | 25/32 | 13/32 | 7/8 | 7/16 | 3/16 | 17.70 |
| 3BK160H | 15.75 | 15.00 | 15.40 | 14 | 3 | 2 1/2 | 1 1/4 | 25/32 | 13/32 | 7/8 | 7/16 | 3/16 | 21.00 |
| 3BK190H | 18.75 | 18.00 | 18.40 | 17 | 3 | 2 1/2 | 1 1/4 | 25/32 | 13/32 | 7/8 | 7/16 | 3/16 | 25.80 |



TYPE 1

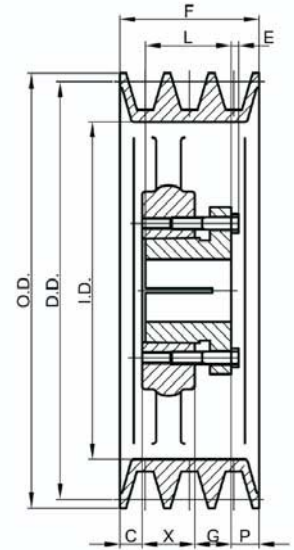

TYPE 2