

Bendix® E-2™ Brake Valve (Basic)

- Available Remanufactured Exchange
- Maintenance Kits
 - Pc. No. 276119N Minor Repair
 - Pc. No. 289324N Major Repair

Treadle and Mounting Plate not furnished.

V.M.R.S. 13-010-019
 i SD-03-812

Reman. Exch. Pc. No.	Service New Pc. No.	A Pipe Thread (Delivery)
229500RX	229500N	3/8"
229501RX	229501N	1/2"

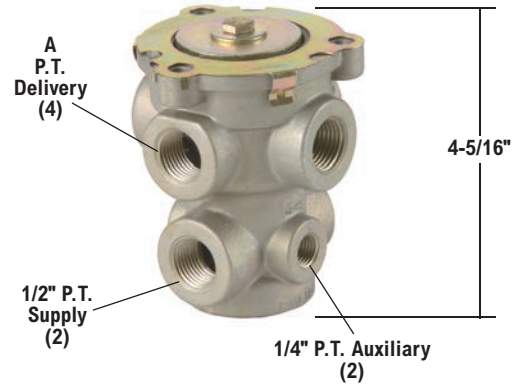

Bendix® E-3™ Brake Valve (Basic)

- Available Remanufactured Exchange
- Maintenance Kits
 - Pc. No. 276119N Minor Repair
 - Pc. No. 289329N Major Repair

Treadle and Mounting Plate not furnished.

V.M.R.S. 13-010-019
 i SD-03-812

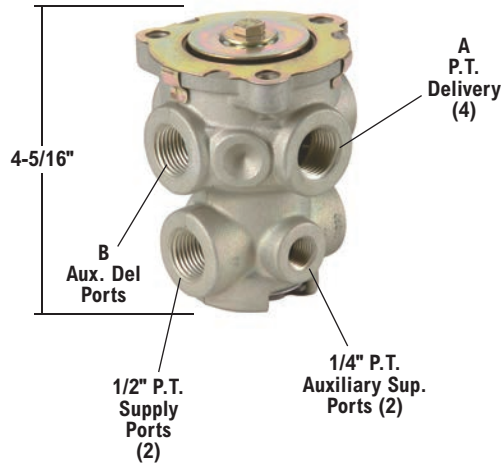

Reman. Exch. Pc. No.	Service New Pc. No.	A Pipe Thread (Delivery)	B Auxiliary Ports
277863RX	277863N	1/2"	NONE
278998RX	278998	1/2"	2-1/4"

Bendix® E-5™ Brake Valve (Basic)

- Available Remanufactured Exchange
- Maintenance Kits
 - Pc. No. 281084N Minor Repair
 - Pc. No. 289334N Major Repair

Pedal and Mounting Plate not furnished.

V.M.R.S. 13-010-019
 i SD-03-816

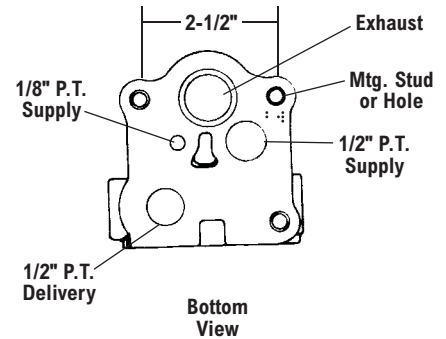
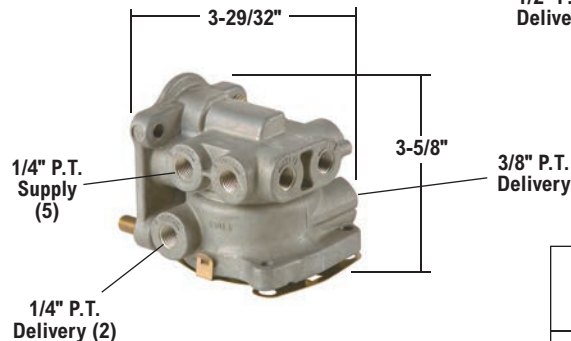

Service New Pc. No.
279950N

Bendix® E-6® Dual Brake Valve (Basic)

- Available Remanufactured Exchange
- Maintenance Kits
 - Pc. No. 287368N Minor Repair
 - Pc. No. 5019319 Minor Repair - High Temp
 - Pc. No. 289335 Major Repair

Treadle and Mounting Plate not furnished.

V.M.R.S. 13-010-051
 i [SD-03-817](#)

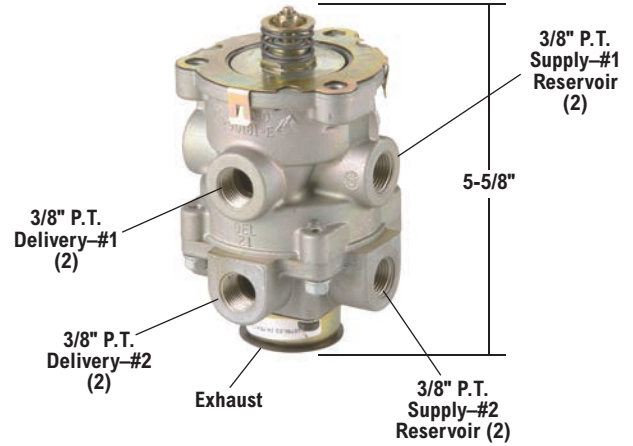

Typical E-6 Brake Valve Assembly and Service Parts				
Service New Assembly Pc. No.	Service New Valve Pc. No.	Treadle	Mounting Plate	Plunger
286173N	286171N	226834N	236979N	236981N

Reman. Exch. Pc. No.	Service New Pc. No.	Comments
286171RX	286171N	
-	802911	High Temp.

Bendix® E-8P®, E-10P™ & E-10PR™ Dual Brake Valves

- Maintenance Kits
 - Pc. No. 287368N Minor Repair
 - Pc. No. 5019319 Minor Repair - High Temperature
 - Pc. No. 289335 Major Repair

V.M.R.S. 13-010-051
 i [SD-03-830](#) and [SD-03-832](#)

Service New Bendix® E-8P® Brake Valve	Replaces Bendix® E-12™ Brake Valve	Comments*
800629	065313, 800583	Lower Body Rotated 90°
800630	065458	Lower Body Rotated 90°
800631	065460, 800407	1/2" NPT Exhaust
802924	—	High Temp
800599	—	PTC Fittings
5008547	800171	Includes Valve and Plunger

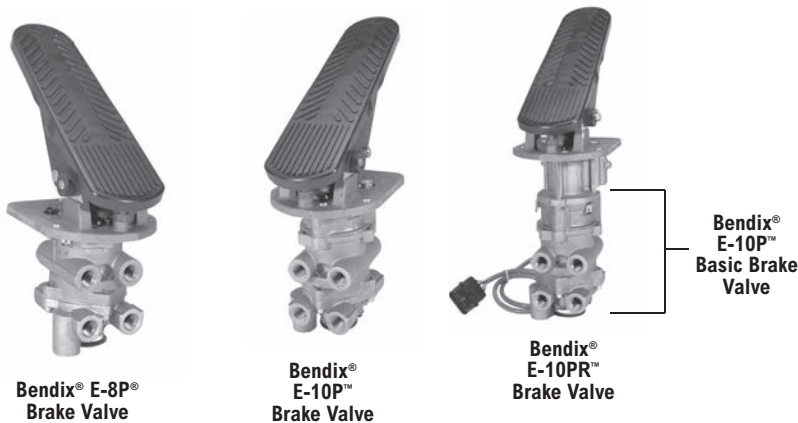

Service New Bendix® E-10P™ Brake Valve	Replaces Bendix® E-15™ Brake Valve
800632	065315 800318

Service New Bendix® E-10P™ Brake Valve	Replaces Bendix® E-15™ Brake Valve
800632	800319

*PTC - Push-To-Connect Fittings

Typical E-8P Brake Valve Assembly and Service Parts					
Service New Assembly Pc. No.	Mounting Plate and Treadle	Treadle	Mounting Plate	Treadle	Plunger
800633	103197N	109428	236979N	109176	112336

Bendix® E-7™ Dual Brake Valve (Basic)

- Available Remanufactured Exchange
- Maintenance Kits
 - Pc. No. 289352 Minor Repair
 - Pc. No. 289353 Major Repair
 - Pc. No. 261047 O-Ring Kit

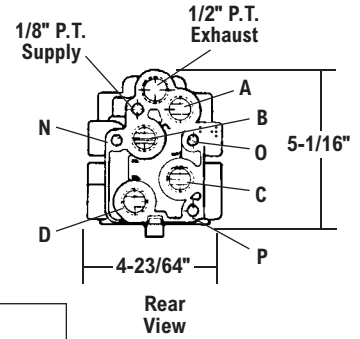
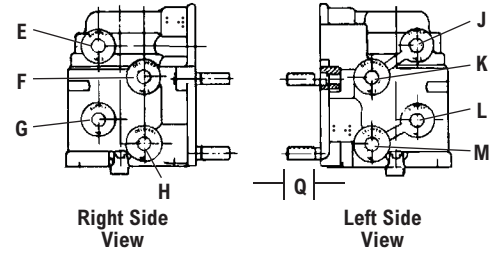

Pedal and Mounting Plate not furnished.

V.M.R.S. 13-010-051

[SD-03-818](#)

Reman. Exch. Pc. No.	Service New Pc. No.	Port Thread Sizes & Locations												Mtg. Studs in Positions "N", "O" "P" Above	Stud Length Q	Stud Thread Size
		A	B	C	D	E	F	G	H	J	K	L	M			
†284760RX	†284760N	No Thd	No Thd	No Thd	No Thd	1/4	-	1/4	-	-	-	-	-	No	-	-
286773RX	286773	1/2	1/2	1/2	1/2	1/4	1/4	1/4	1/4	1/4	1/4	1/4	1/4	Yes	1-1/2"	3/8"-24
286775RX	-	1/2	1/2	1/2	1/2	1/4	1/4	1/4	1/4	1/4	1/4	1/4	1/4	Yes	3/4"	3/8"-16
287411RX	287411N	1/2	1/2	1/2	1/2	1/4	1/4	1/4	1/4	3/8	3/8	3/8	3/8	No	-	-
*287564RX	*287564N	1/2	1/2	1/2	1/2	1/4	3/8	1/4	3/8	1/4	1/4	1/4	1/4	Yes	15/16"	3/8"-16
*288383RX	*288383N	1/2	1/2	1/2	1/2	1/4	1/4	1/4	1/4	1/4	1/4	1/4	1/4	No	-	-
101818RX	101818N	1/2	1/2	1/2	1/2	1/4	3/8	1/4	3/8	1/4	3/8	1/4	3/8	No	-	-

† Ford® Basic Valve Kit: Includes a basic valve and 10 sealing rings.

* Exhaust port contains a diaphragm.

Bendix® E-10™ Dual Brake Valves (Basic)

- Maintenance Kit
 - Pc. No. 102100

Treadle and Mounting Plate not furnished.

V.M.R.S. 13-010-051

[SD-03-817](#)

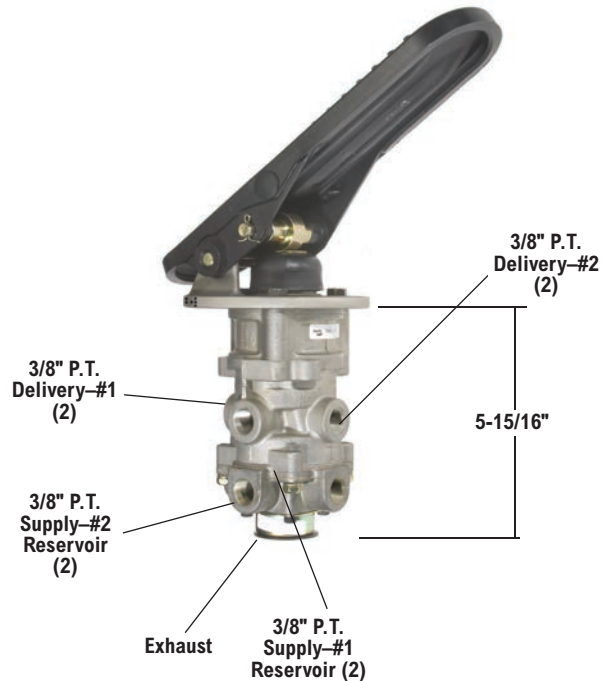

Reman Exch. Pc. No.	Service New Pc. No.
101100RX	101100N

Bendix® E-12™ & E-15™ Dual Brake Valves

• Maintenance Kit Pc. No. 108367 Minor Repair

V.M.R.S. 13-010-051

[SD-03-826](#)

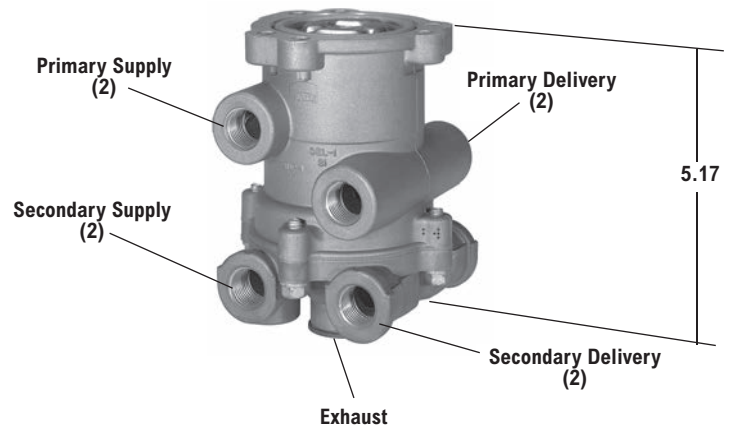

Bendix® E-14™ Dual Brake Valve (Basic)

• Maintenance Kit Pc. No. 108367 (Minor Repair)

V.M.R.S. 13-010-051

[SD-03-828](#)

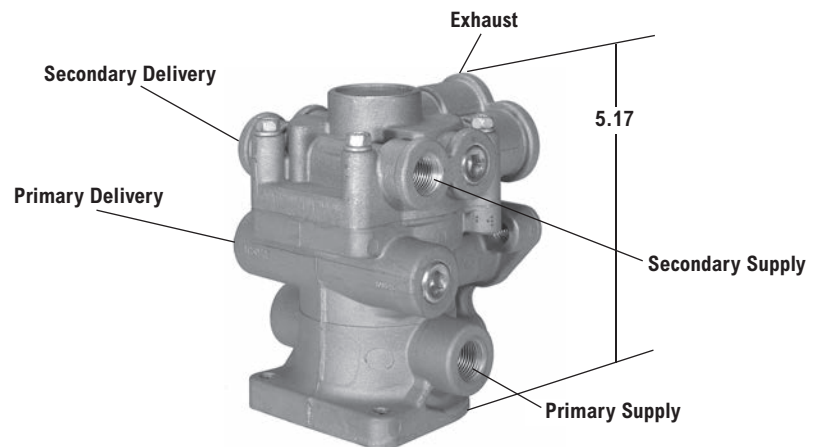

Bendix® BVA-85™ Brake Valve Actuator

Service New Pc. No.	Comments*
5009593	1/4" PTC Port
5009594	1/4" NPT Port
K039060	1/4" NPT Port - High Temp.

*PTC - Push-To-Connect Fittings

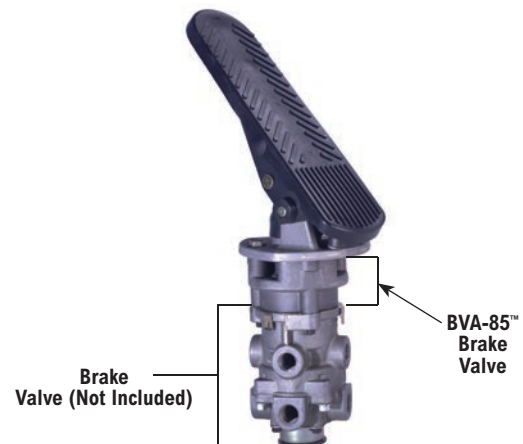

Bendix® TC-2™ Brake Valve (Basic)

- Available Remanufactured Exchange
- Maintenance Kit Pc. No. 276122

Handle not furnished.

V.M.R.S. 13-010-014

[SD-03-813](#)

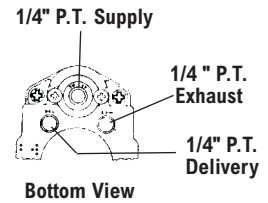
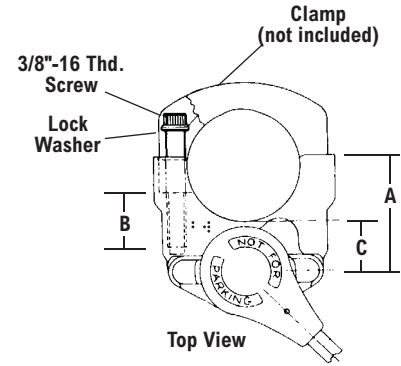

Reman. Exch. Pc. No.	Service New Pc. No.	Graduated Range Pressure (psi)	Final Delivery Pressure (psi)	A	B Thd./Drill Depth	C
-	101460	5-125	125	2.35"	1.4"	.97"
276270RX	276270N	5-80	Reservoir	3.44"	1.1"	2.1"
-	800172	5-125	Reservoir	1.25"	Through	.09"
-	800173	5-80	80	1.25"	Through	.09"
-	802634	5-80	80	3.44"	1.1"	2.1"

Bendix® TC-6™ Brake Valve

- Maintenance Kit Pc. No. 289890

Mounting Plate not furnished.

V.M.R.S. 13-010-159

[SD-03-821](#)

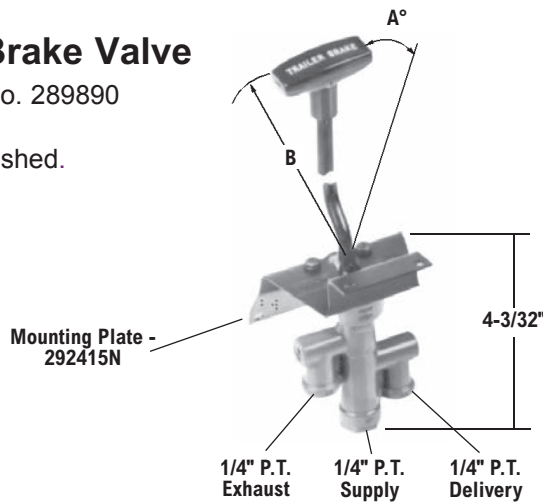

Service New Pc. No.	Handle		Final Delivery Pressure (psi)
	A°	B	
065512	55	7.03"	85
106385	55	8.93" Self-returning	85
101786N	75	8.52"	120
289884N	75	4.5"	120
289885N	75	4.5"	50
5003601N	55	8.9"	85

Bendix® TC-7™ Brake Valve

- Maintenance Kit Pc. No. 102145

Handle and Mounting Bracket not furnished.

V.M.R.S. 13-010-159

[SD-03-824](#)

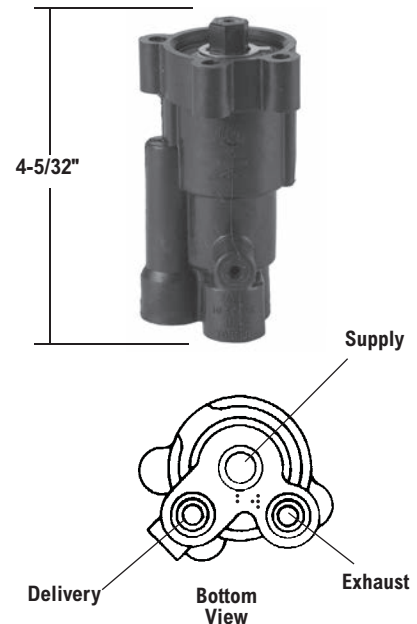

Service New Pc. No.	Comments	Handle Travel	Final Delivery Pressure	Port Sizes
101860	Positioning	71° CW	Reservoir	1/4" PT
102394N	Self-returning.	71° CW	Reservoir	1/4" PT
102707	Positioning	50° CW	80 psi	1/4" PT
108233N	Self-returning.	50° CW	80 psi	1/4" PT
800960	Positioning	71° CW	Reservoir	3/8" PTC
802672	Self-returning.	71° CW	Reservoir	3/8" PTC

*PTC - Push-To-Connect Fittings

Bendix® TCS-9000™ Control Valve

[SD-03-3674](#)

Service New Pc. No.	Supply	Delivery	Comments	Handle Text
802033	3/8"	3/8"	Self-returning	No Handle Cap
K031988	3/8"	3/8"	Self-returning	No Handle Cap
K024944	1/4"	1/4"	Self-returning	Rear Brake
K024946	3/8"	3/8"	Self-returning	Trailer Brake
K024947	3/8"	3/8"	Self-returning	Rear Brake
K024948	3/8"	3/8"	Positioning	Trailer Brake - Not for Parking

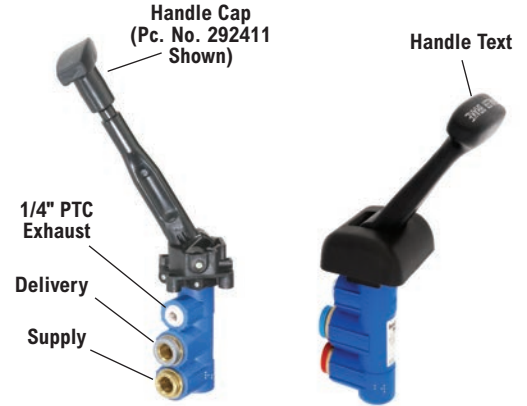

*PTC – Push-To-Connect Fittings

Bendix® TR-2™ Inversion Valve

- Available Remanufactured Exchange
- Maintenance Kit 281138N

V.M.R.S. 13-010-047

[SD-03-4650](#)

NOTE: With 125 psi supply pressure, valve must begin to exhaust at 65 psi nominal ascending control pressure. Valve must deliver full supply pressure with 40 psi nominal descending control pressure.

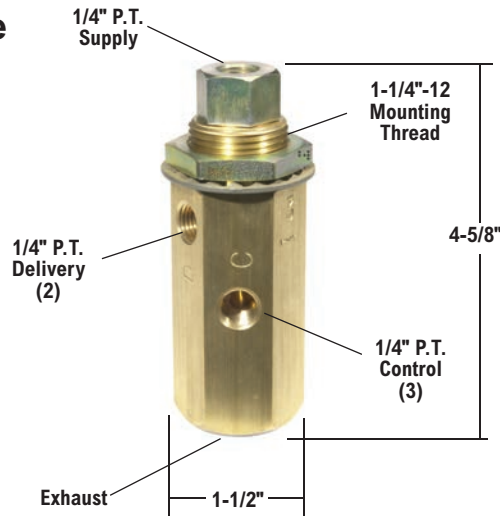

Reman. Exch. Pc. No.	Service New Pc. No.	Comments
277340RX	277340N	—
—	101125N	Brass Body

Bendix® TR-3™ Inversion Valve

- Available Remanufactured Exchange

V.M.R.S. 13-010-047

[SD-03-4650](#)

NOTE: With common control & supply pressure, inlet opens at “A” descending pressure and exhaust opens at “B” ascending pressure.

Reman. Exch. Pc. No.	Service New Pc. No.	A (psi)	B (psi)
—	280758N	45	60
281318RX	281318N	35	70
281459RX	281459N	25	40
*101450RX	*101450N	25	40

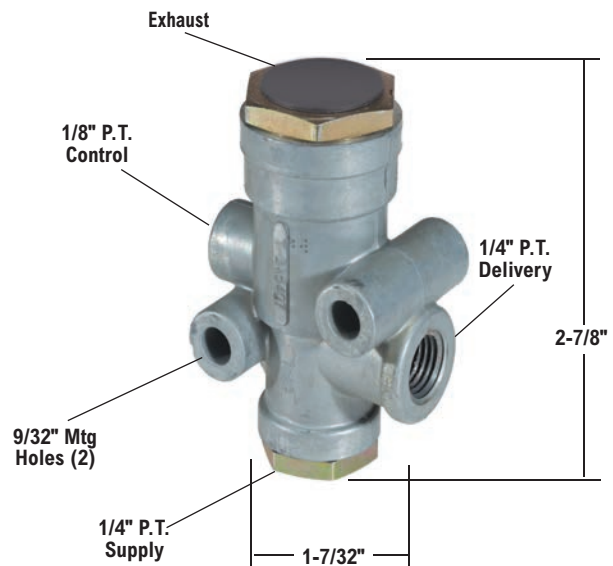

*Special-Duty Bus Application