

Bendix® PP-1® Control Valve

- Available Remanufactured Exchange
- Maintenance Kit 281126N
- Button and Mounting Nut not furnished with Exchange Valve - common Pc. No. 239357
- Typical Button (Yellow) and Pin Kit Pc. No. 102087N
- Typical Mounting Nut Pc. No. 239357N

V.M.R.S. 13-010-016

[SD-03-3611](#)

Reman. Exch. Pc. No.	Service New Pc. No.	Automatic Release Pressure (psi)	Delivery Port (P.T.)
276566RX	276566N	20	1/8"
276567RX	276567N	40	1/8"
278450RX	278450N	—	1/8"
*281587RX	—	40	1/8"
283828RX	283828N	60	1/8"
287417RX	287417N	30	1/4"
287600RX	287600N	40	1/4"

*Remote controlled

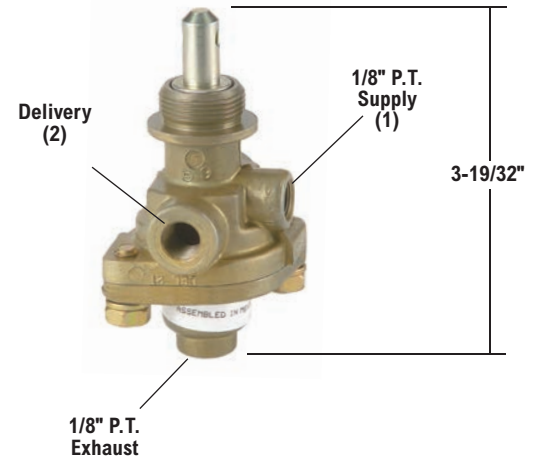

Bendix® PP-2™ Control Valve (Pressure Balanced)

- Available Remanufactured Exchange
- Maintenance Kit 281127N
- Button and Mounting Nut not furnished with Exchange Valve

V.M.R.S. 13-010-104

[SD-03-3611](#)

Reman. Exch. Pc. No.	Service New Pc. No.	Automatic Release Pressure (psi)
276462RX	276462N	40

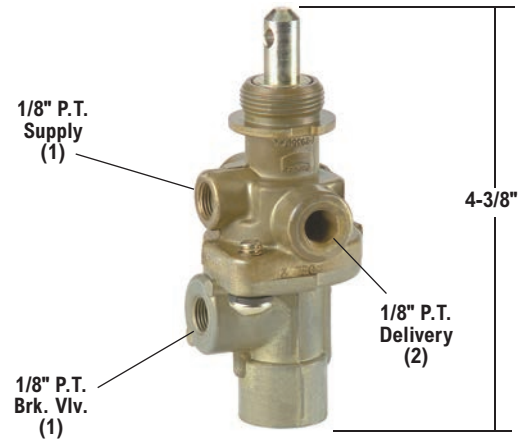

Bendix® PP-3™ Control Valve (Automatic Tripper)

- Available Remanufactured Exchange
- Maintenance Kit 280857N
- Button and Mounting Nut not furnished with Exchange Valve

V.M.R.S. 13-010-016

[SD-03-3613](#)

Reman. Exch. Pc. No.	Service New Pc. No.	Delivery (P.T.)
†*279787RX	†*279787	None
288746RX	288746N	None
289477RX	289477	1/8"
*289512RX	—	1/8"

Tripper Exhausts at 30 psi & Charges above 50 psi. Plunger Trips at 40 psi and Charges Manually.

*Remote Controlled
†Mounting Nut Furnished

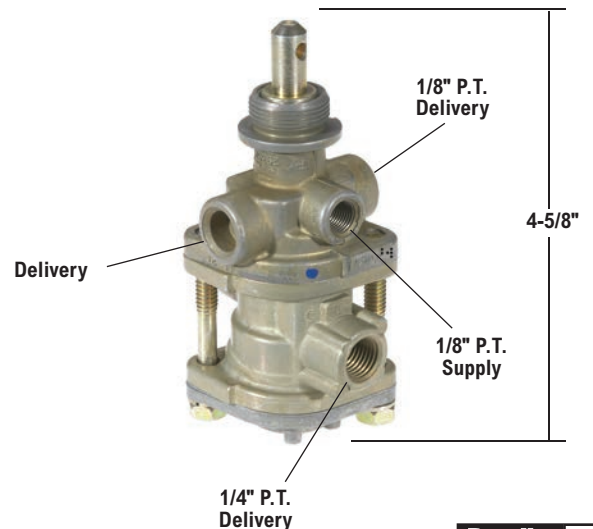

Bendix® PP-5™ Control Valve (With Pilot Air Release)

- Maintenance Kit 281949
- Button is Furnished with Valve Pc. No. 284744N

V.M.R.S. 13-010-104

[SD-03-3611](#)

Service New Pc. No.	Automatic Release Pressure (psi)
281946N	40
284744N	Manual

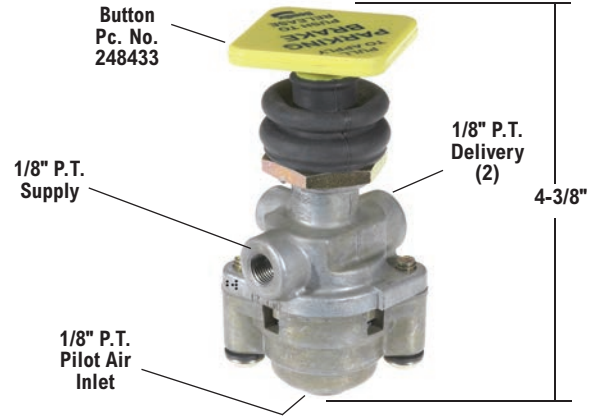

Bendix® PP-7™ Trailer Supply Valve

- Available Remanufactured Exchange
- Maintenance Kit 287367
- Button and Mounting Nut not furnished with Exchange Valve
- Typical Button (Red) Pc. No. 291624N
- Typical Mounting Nut Pc. No. 239357N

V.M.R.S. 13-010-016

[SD-03-3617](#)

Automatic Release Pressure 40 psi

Reman. Exch. Pc. No.	Service New Pc. No.	Comments
288239RX	288239N	-
288241X	106113	1/4" Exhaust (P.T.)
288242RX	288242	Remote Controlled

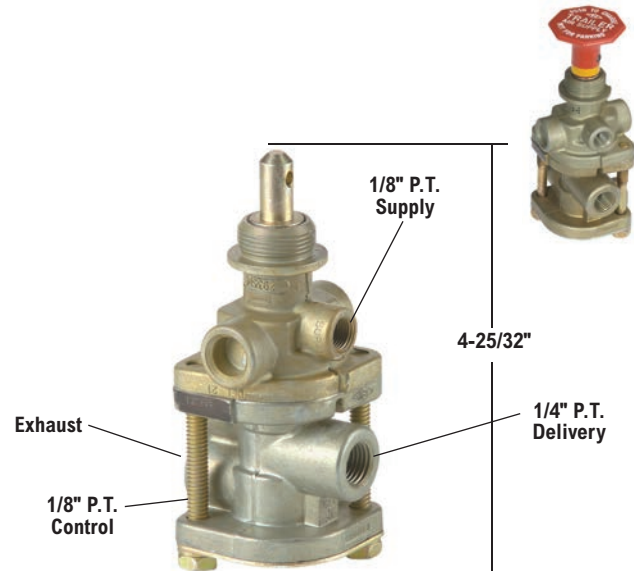

Bendix® PP-8™ Control Valve

- Available Remanufactured Exchange
- Button and Mounting Nut not furnished with Exchange Valve

V.M.R.S. 13-010-104

[SD-03-3611](#)

Reman. Exch. Pc. No.	Service New Pc. No.	Delivery Port (P.T.)
287238RX	287238N	1/8"
287418RX	287418N	1/4"

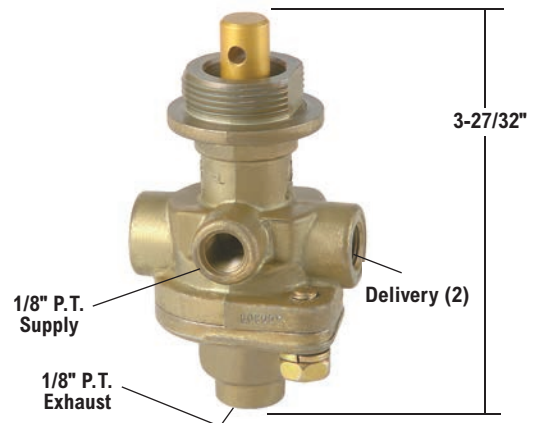

Bendix® RD-3™ Push Type Control Valve

- Available Remanufactured Exchange
- Maintenance Kit 281126N
- Button not furnished with Exchange Valve, Roll Pin Furnished
- Refer to Master Parts Catalog for Button or Dial Plate Pc. No.

V.M.R.S. 13-010-104

[SD-03-3611](#)

Service New Pc. No.	Comments
286211N	—
104644	See View 1

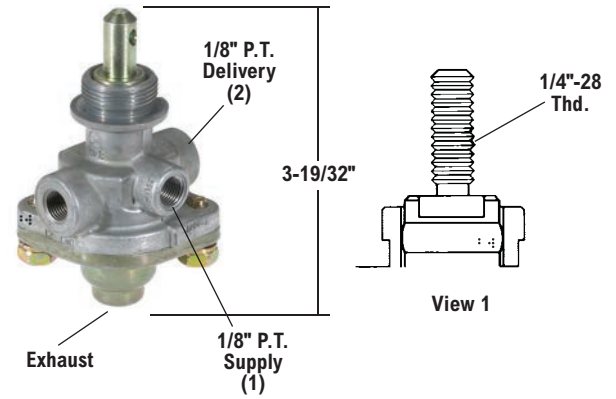

Bendix® E-Z-Grip® Soft Button Cover

Service New Pc. No.	Button Shape	Description
801526		Fits Bendix® MV-3®/PP-DC® Valve Style
801593		Fits Bendix® PP-1® Valve Style
802123		Fits Bendix® PP-7™ Valve Style
802124	and	Contains both Bendix® MV-3® Button Covers



Button not included

Bendix® PP-DC® Control Valve

• Maintenance Kit 5006939

V.M.R.S. 13-101-017

[SD-03-3619](#)

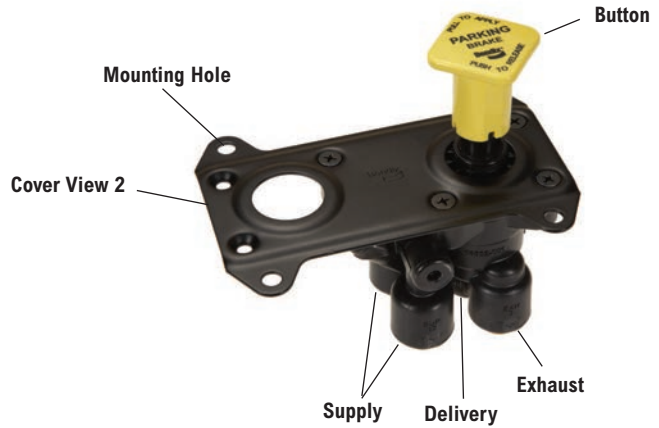
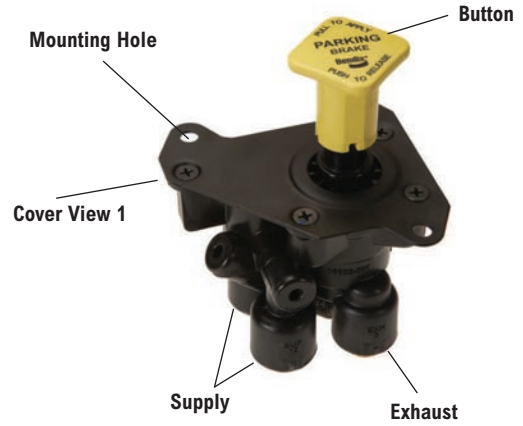
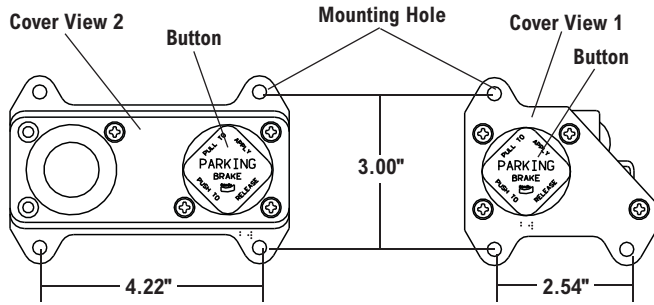

Service Pc. No.	Cover View	Mounting Holes	Port Type*
065643	2	.27" Dia.	3/8" PTC
065661	1	1/4-20 Thread	3/8" PTC
065690	1	.27" Dia.	3/8" PTC
800034	2	.27" Dia	1/4" NPT
800142	1	1/4-20 Thread	1/4" NPT
800309	3	M6 x 1-6H	3/8" PTC
800620	4	M8 x 1-6H	3/8" PTC
800841	2	M6 x 1-6H	3/8" PTC
801315	2	.27" Dia	3/8" PTC Elbow

*PTC - Push-To-Connect Fittings

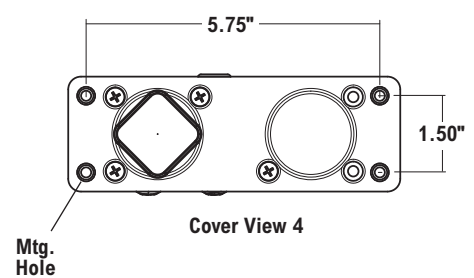
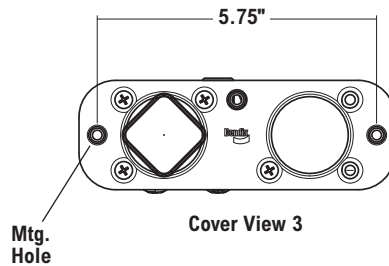

Bendix® MV-3® Control Module

- Maintenance Kit 5002741
- Shuttle Kit 5002742

V.M.R.S. 13-010-112

[SD-03-3415](#)



Typical Yellow Button Pc. No. 298818N
 Typical Red Button Pc. No. 298817N

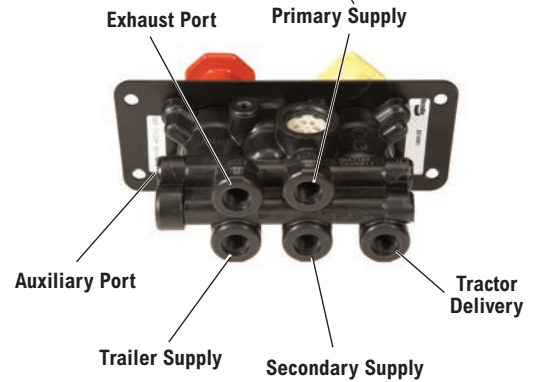
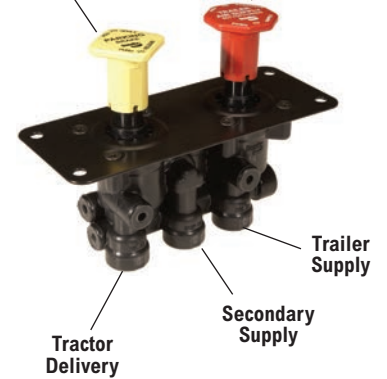

Service New Pc. No.	Replaces	Cover View	Mounting Hole	Auxiliary Port	Port Type*
800257	065523	1	.28" Dia.	—	3/8" PTC
800259	800036	1	1/4-20 Thread	—	3/8" PTC
800260	—	1	M5 x .8-6H Thread	—	3/8" PTC
800445	—	2	.27" Dia.	—	1/4" NPT
800516	065157	1	.28" Dia.	—	1/4" NPT
	065697				
800517	065159	2	#10-24 Thread	—	1/4" NPT
	065379				
800518	065160	1	.28" Dia.	1/8" NPT	1/4" NPT
800519	065186	1	1/4-20 Thread	—	1/4" NPT
800521	065192	3	1/4-20 Thread	—	1/4" NPT
800522	065208	1	M6 x 1-6H Thread	1/8-27	1/4" NPT
800523	065248	1	#10-24 Thread	—	1/4" NPT
800573	065187	1	1/4-20 Thread	—	1/4" NPT
801631	5012393	4	.20" Dia.	—	3/8" PTC Elbow
K031485	K031484	1	1/4-20 Thread	—	3/8" PTC Elbow

*PTC - Push-To-Connect Fittings

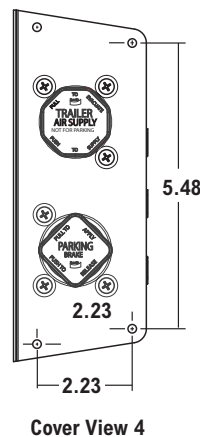
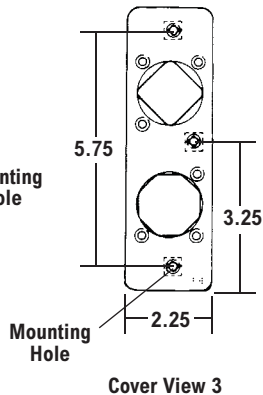
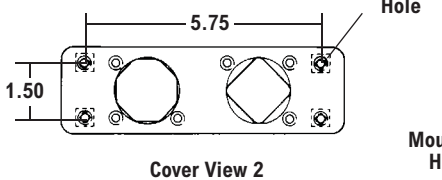
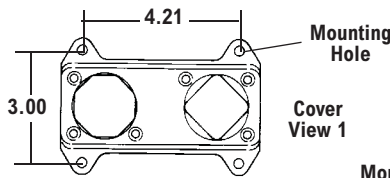

WARNING

The exhaust port may contain a composite (non-metallic) fitting. This fitting does not meet Department of Transportation (DOT) standards for pressurized air lines and is for non-pressurized exhaust air lines only. Installing a Bendix® MV-3® control valve that contains this fitting in an application that uses pressurized air in this port could cause a sudden application of the parking brakes.



Bendix® MV-3® Valve with Push-to-Connect Fittings

Bendix® TC-4™ Modulating Control Valve (With Lever Latch)

- Available Remanufactured Exchange
- Dial Plate not furnished with Exchange Valve

V.M.R.S. 13-010-104

[SD-03-4503](#)

Reman. Exch. Pc. No.	Service New Pc. No.	Locking Button Position	Delivery Pressure (psi)	Comments
282368RX	282368N	LEFT	86-100	–
–	282382N	LEFT	86-100	Includes Dial Plate

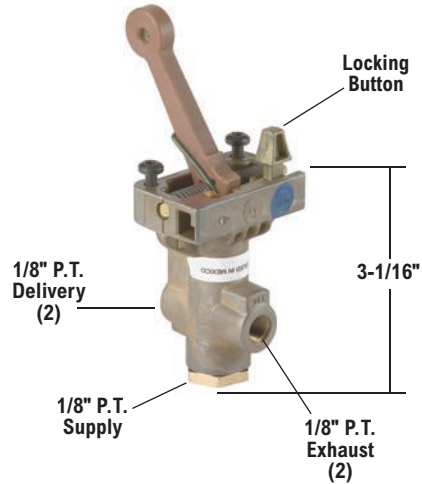

Bendix® TW-1™ Control Valve

- Available Remanufactured Exchange
- Dial Plate not furnished with Exchange Valve

V.M.R.S. 13-016-016

[SD-03-3602](#)

Reman. Exch. Pc. No.	Service New Pc. No.	Lever Material and Finish
228729RX	228729N	Zinc-Chrome
229635RX	229635N	Steel-Chrome
277516RX	277516N	Nylon-Black

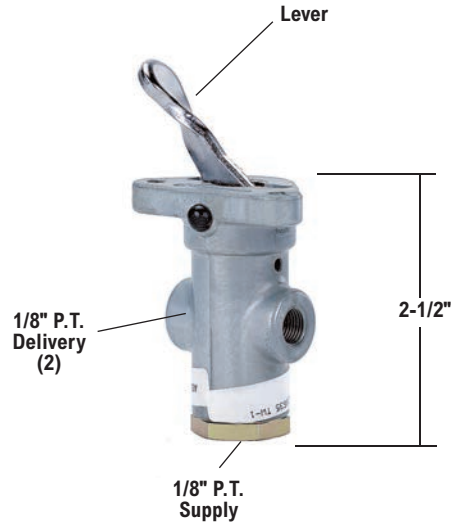

Bendix® TW-2™ & TH-3™ Control Valve

- (TW-2 Control Valve Two Lever Positions)
- (TH-3 Control Valve Three Lever Positions)
- Available Remanufactured Exchange
- Maintenance Kit 282391
- Dial Plate not furnished with Exchange Valve

Service New TW-2™ Control Valve Pc. No.	Service New TH-3™ Control Valve Pc. No.	Lever
280905N	280904N	Centering
–	281560N	Positioning

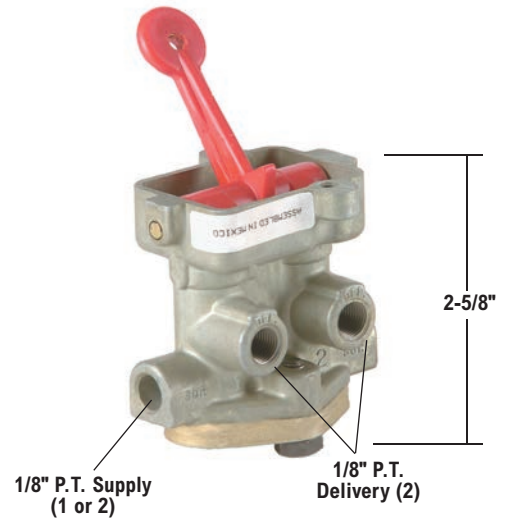

Bendix® TW-3™ Control Valve

- Available Remanufactured Exchange
- Dial Plate not furnished with Exchange Valve

V.M.R.S. 13-010-016

[SD-03-3602](#)

Reman. Exch. Pc. No.	Service New Pc. No.	Lever Material
225892RX	225892N	Zinc
228762RX	228762N	Steel
283040RX	283040N	Steel

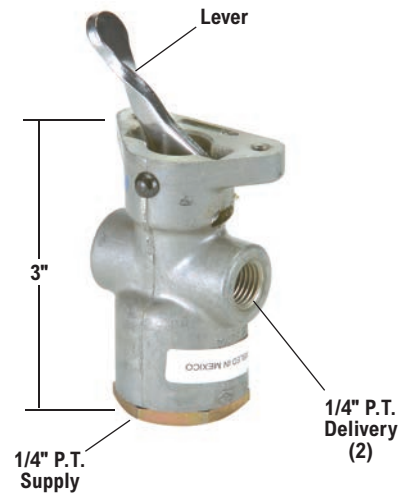

Bendix® TW-4™ Control Valve

- Available Remanufactured Exchange
- Refer to Master Parts Catalog for Button Pc. No.

V.M.R.S. 32-004-007

[SD-03-3602](#)

Service New Pc. No.
276635N

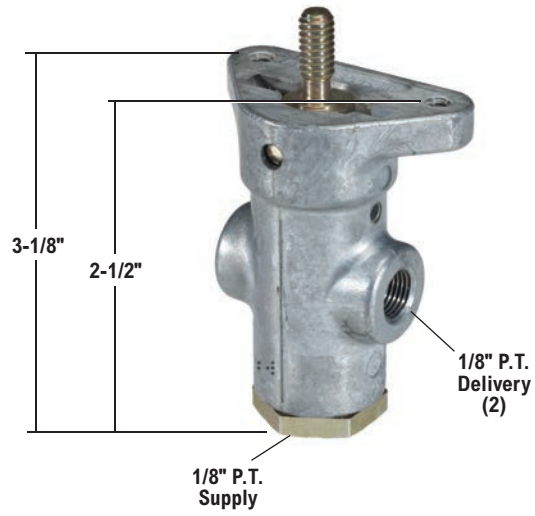

Bendix® TW-11™ Control Valve

- Used in conjunction with the Bendix® HR-1™ Hydraulic Relay Valve

Service New Pc. No.	Configuration
065356	Fig. B
065316	Fig. A

Fig. B

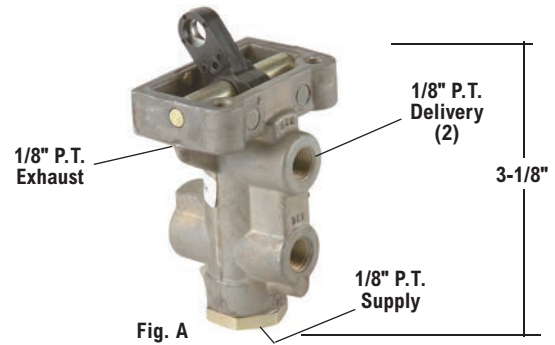
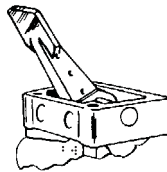

Bendix® SV-1™ Synchronizing Valve

i SD-03-4020

Service New Pc. No.	A (psi)	B (psi)
278825N	42	28
282472N	21	11
283700N	62	50

With Common Control & Supply Pressure, Inlet Opens at A and Exhaust Opens at B

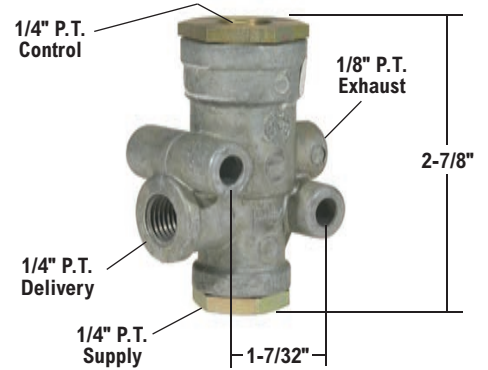

Bendix® SV-4™ Trailer Release Valve

i SD-03-4020

Service New Pc. No.	Breather Valve Size/Shape
108769	1" Hex
109149	9/16" 12 point

