

Bendix® QR-L™ Inline Quick Release Valve

V.M.R.S. 13-010-008

[SD-03-906](#)

| Service New Pc. No. | Comments |
|---------------------|------------------------|
| 800332 | Frame or Bracket Mount |
| 800333 | Direct Mount |

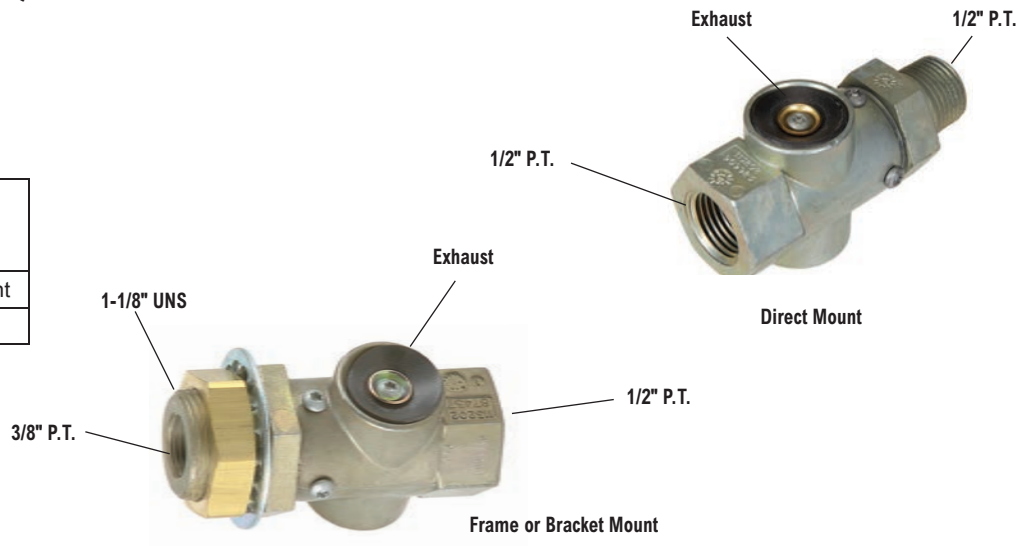

Bendix® RV-3™ Pressure Reducing Valve

[SD-03-3515](#)

| Service New Pc. No. | Delivery Pressure (psi) |
|---------------------|-------------------------|
| 101837N | 85 |
| 107154N | 44 |

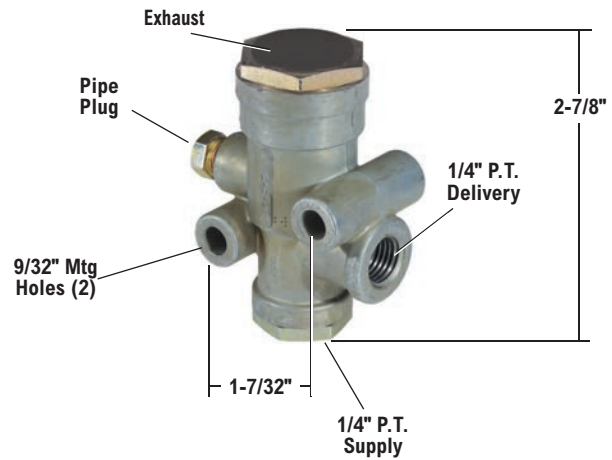

Bendix® QR-1® Quick Release Valve

- Available Remanufactured Exchange
- Use maintenance kit piece no. 260519 to convert 0 psi crack pressure valves to 1 psi

V.M.R.S. 13-010-008

[SD-03-901](#)

| Reman. Exch. Pc. No. | Service New Pc. No. | Supply Port (PT) | Delivery Ports (PT) | Crack Pressure (psi) | Comments |
|----------------------|---------------------|------------------|---------------------|----------------------|-----------------|
| 229813RX | 229813N | 3/8" | 1/4" | 0 | |
| 229844RX | 229844N | 1/2" | 1/4" | 0 | |
| 229859RX | 229859N | 3/8" | 3/8" | 0 | |
| 229860RX | 229860N | 1/2" | 3/8" | 0 | |
| 281024RX | 281024N | 1/4" | 1/4" | 0 | |
| 288251RX | 288251N | 3/8" | 3/8" | 0 | 3/8" PT Exhaust |
| 278483RX | 278483N | 1/2" | 3/8" | 5-8 | |
| - | 102344N | 3/8" | 3/8" | 10-16 | |
| 289525RX | 289042N | 3/8" | 1/4" | 1 max | w/ insert |
| 289525RX | 289525N | 3/8" | 3/8" | 1 max | w/ insert |

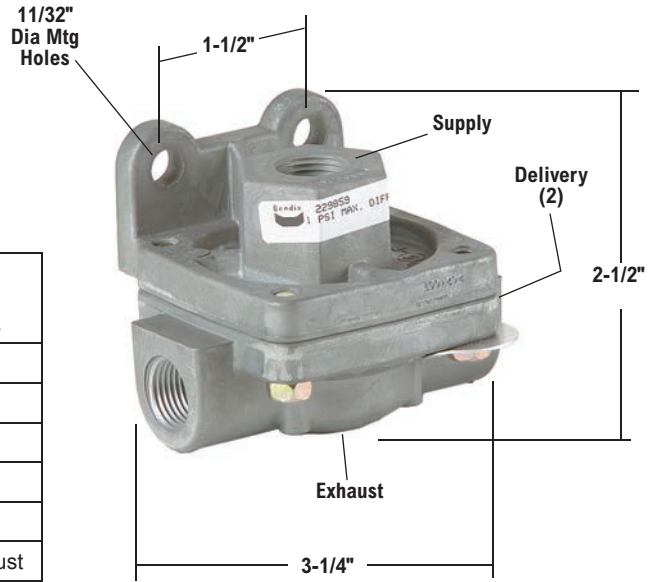

Bendix® QRN™ Quick Release Valve

- Maintenance Kit 104463

V.M.R.S. 13-010-008

[SD-03-905](#)

| Service Part No. | Mounting Hole or Slot | Differential Pressure (psi) | Supply Port* | Delivery Port* |
|------------------|-----------------------|-----------------------------|--------------|----------------|
| 802741 | .34" Dia | 5-8 | 3/8" PT | 3/8" PT |
| 802742 | .34" Dia | 5-8 | 1/2" PT | 3/8" PT |
| 802743 | .34" Dia | 1 Max | 3/8" PT | 3/8" PT |
| 802744 | Slot .75 x .34 in | 1 Max | 3/8" PT | 3/8" PT |
| 802745 | .34" Dia | 1 Max | 1/2" PT | 3/8" PT |
| 803074 | Slot .75" x .34" | 2-4.5 | 3/8" PT | 3/8" PT |
| 803075 | Slot .75" x .34" | 2-4.5 | 1/2" PT | 3/8" PT |
| 803076 | Slot .75" x .34" | 4.5-7.5 | 3/8" PT | 3/8" PT |
| 803077 | Slot .75" x .34" | 4.5-7.5 | 1/2"-14 PT | 3/8" PT |
| K022145 | .34" Dia | 1 Max | 3/8" PT | 3/8" PT |
| K027097 | N/A | 1 Max | 1/2" PT | 3/8" PT |
| K027098 | N/A | 2-4.5 | 1/2" PT | 3/8" PT |
| K049775 | Slot .75" x .34" | 0 | 1/2" PTC | 1/2" PTC |
| K049776 | Slot .75" x .34" | 0 | 1/2" PT | 3/8" PT |
| K049777 | Slot .75" x .34" | 0 | 3/8" PT | 3/8" PT |

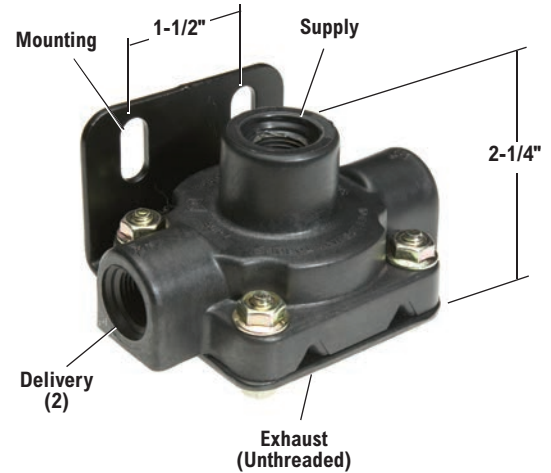

| Silencer Kit Complete (Adapter & Silencer) | Silencer Adapter | Silencer |
|--|------------------|----------|
| K028796 | K023669 | K028795 |

*PTC - Push-To-Connect Fittings

Bendix® QR-1C® Quick Release Valve

- Available Remanufactured Exchange
- Use maintenance kit piece no. 260519 to convert 0 psi crack pressure valves to 1 psi

V.M.R.S. 13-010-008

[SD-03-904](#)

| Reman. Exch. Pc. No. | Service New Pc. No. | Delivery Port (P.T.) | Exhaust Port (P.T.) | Crack Pressure (psi) |
|----------------------|---------------------|----------------------|---------------------|----------------------|
| 289182RX | 289182N | 1/4" | – | 0 |
| 289714RX | 289714N | 3/8" | – | 0 |
| – | 107881N | 3/8" | 1/2" w/ Silencer | 0 |
| – | 800539 | 3/8" | – | 1 Max |
| – | 109094N | 3/8" | – | 5-8 |

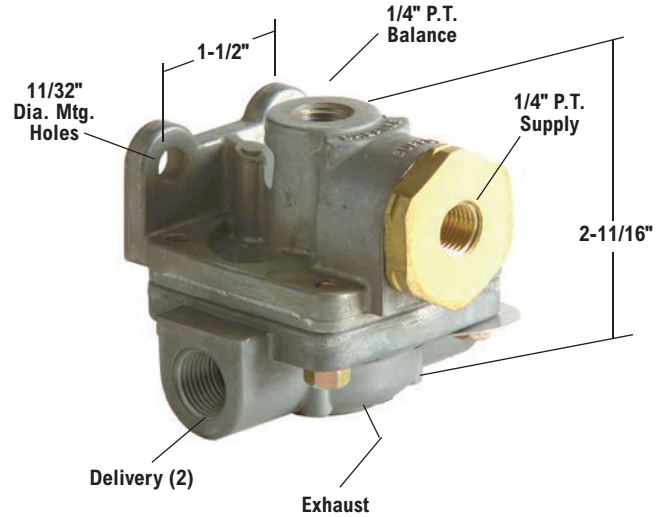

Bendix® LQ-2™ Limiting and Quick Release Valve

- Available Remanufactured Exchange
- Maintenance Kit 282098N

V.M.R.S. 13-010-008

[SD-03-950](#)

| Reman. Exch. Pc. No. | Service New Pc. No. | Supply Port (P.T.) | Delivery Port (P.T.) | Exhaust Port (P.T.) |
|----------------------|---------------------|--------------------|----------------------|---------------------|
| 229505RX | 229505N | 3/8" | 3/8" | – |
| 229507RX | 229507N | 1/2" | 1/4" | – |
| 229509RX | 229509N | 3/8" | 1/4" | – |
| 288417RX | 288417N | 3/8" | 3/8" | 3/8" |

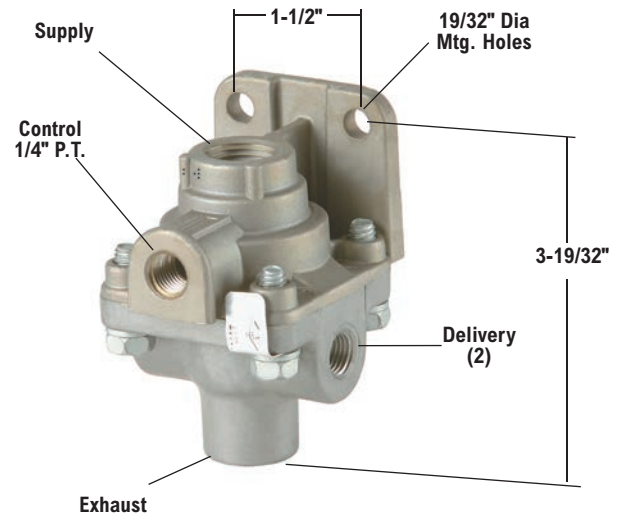

Bendix® LQ-4™ Front Axle Ratio Valve

- Available Remanufactured Exchange
- Maintenance Kit 289500N

V.M.R.S. 13-010-034

[SD-03-951](#)

| Reman. Exch. Pc. No. | Service New Pc. No. | Nominal Hold Off Pressure (psi) | Nominal Equalizing Pressure (psi) |
|----------------------|---------------------|---------------------------------|-----------------------------------|
| 101311RX | 101311N | 20 | 70 |
| 289144RX | 289144N | 4 | 60 |
| 289148RX | 289148N | 10 | 65 |

