

Bendix® R-6™ Relay Valve

- Available Remanufactured Exchange
- Maintenance Kit 280856N

V.M.R.S. 13-010-009

[i SD-03-1060](#)

Reman. Exch. Pc. No.	Service New Relay Valve Pc. No.	A° Service Port Angle	B (P.T.)	C (P.T.)	Mounting Flange
-	279180N	180°	-	3/8"	2 Hole
279952RX	279952N	180°	3/4"	3/8"	2 Hole
280375RX	280375	90°	-	1/2"	2 Hole
279952RX	*280651N	180°	3/4"	3/8"	2 Hole
283940RX	283940N	270°	3/8"	3/8"	4 Hole

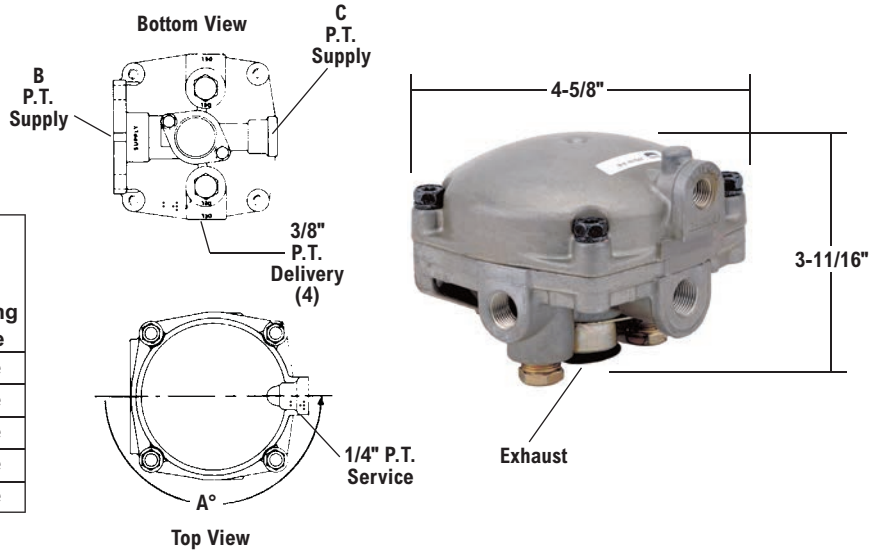

Crack Pressure 2 psi

*Pipe Plugs & Gasket Attached

Bendix® R-8™ Relay Valve

- Available Remanufactured Exchange
- Maintenance Kit 287370N

V.M.R.S. 13-010-009

[i SD-03-1061](#)

Reman. Exch. Pc. No.	Service New Pc. No.	A° Service Port Location	Comments
286370RX	286370N	90°	
286371RX	286371N	90°	No Exh. Cover
287260RX	287260N	180°	No Exh. Cover
288369RX	288369N	180°	
288781RX	288781	180°	Waterproof

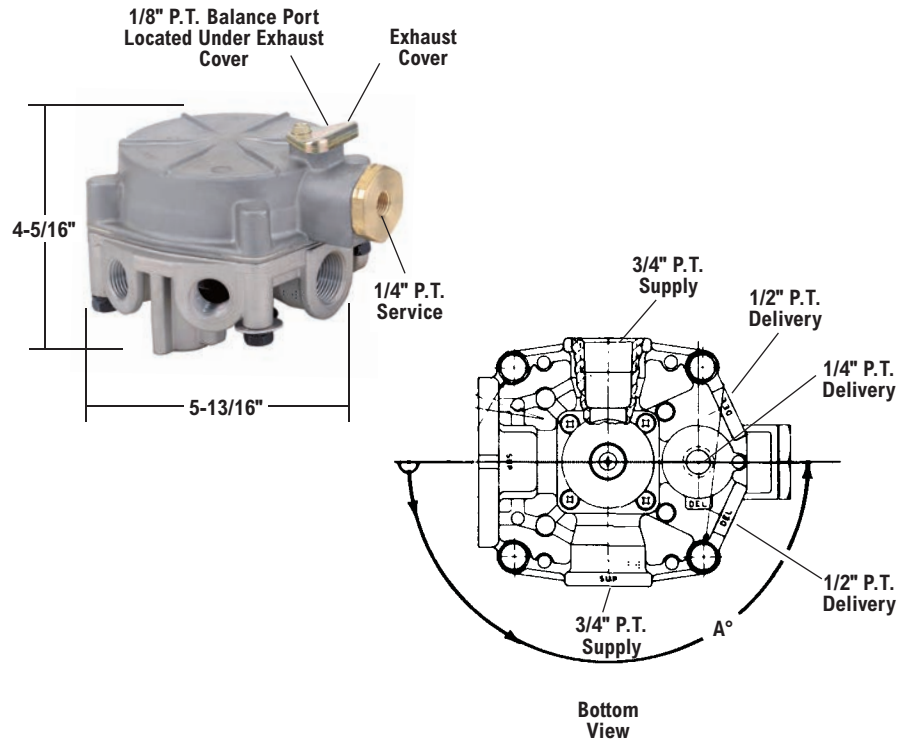

Bendix® R-8P™ Relay Valve

- Available Remanufactured Exchange
- Maintenance Kit 103799

V.M.R.S. 13-010-009

[SD-03-1061A](#)

Reman. Exch. Pc. No.	Service New Pc. No.	Comments
287114RX	287114N	-

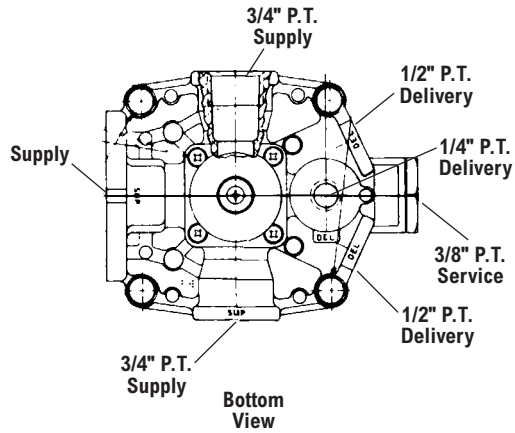
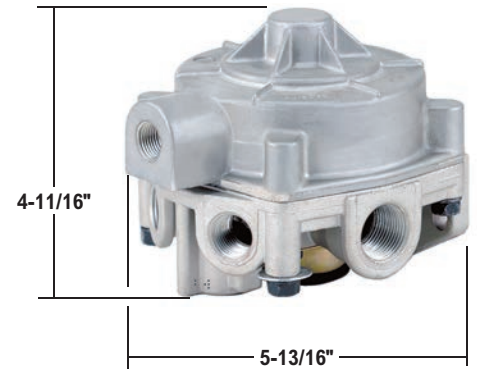

Bendix® R-12® Relay Valves

- Available Remanufactured Exchange
- All Universal Bendix R-12® and R-14® Relay Valves include Installation Instructions and a Universal Mounting Bracket as indicated.
- Field maintenance kit for R-12® and R-14® Relay Valves is Pc. No. 102802N.

V.M.R.S. 13-010-009

[SD-03-1064](#)

Vertical Delivery Ports

Reman. Exch. Pc. No.	Service New Pc. No.	Crack Pressure (psi)	Delivery (P.T.)	Maint. Kit	Mounting Bracket
5003365X	065104	4	3/8"	102802N	296010N
-	065181	5.5	1/2"	102802N	296010N
102626RX	102626N	4	1/2"	102802N	296010N
103912RX	103912	7.5	1/2"	102802N	296010N
104561RX	-	5.5	3/8"	102802N	296010N
-	*800365	4	3/8"	102802N	296010N

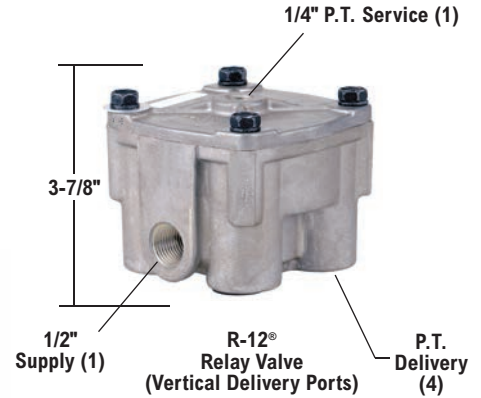
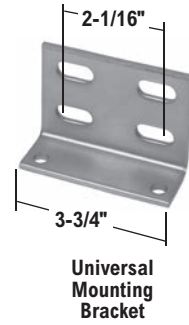

Horizontal Delivery Ports

Reman. Exch. Pc. No.	Service New Pc. No.	Crack Pressure (psi)	Supply Port Size (P.T.)	Maint. Kit	Mounting Bracket	Delivery (P.T.)
-	065125	5.5	1/2"	102802N	296010N	1/2"
-	065309	4	1/2"	102802N	296010N	1/2"
-	065546	4	1/2"	109523	296010N	1/2"
103009RX	103009N	4	3/4"	102802N	296010N	1/2"
104165RX	-	7.5	3/4"	102802N	296010N	1/2"
-	800238	4	3/4"	102802N	N/A	1/2"
-	800305	4	1/2"	5002831	296010N	1/2"
-	*800366	5.5	1/2"	5004029	296010N	3/8"
-	*800365	4	1/2"	5004029	296010N	1/2"
-	801123	4	1/2"	5019003	N/A	1/2" PTC

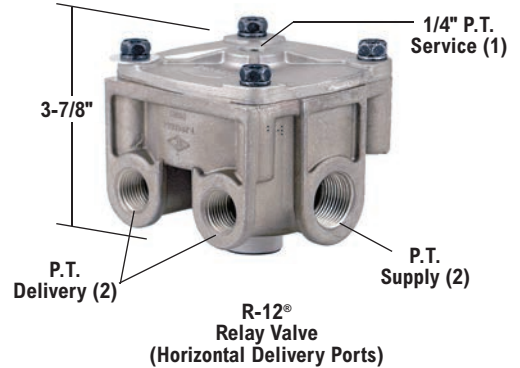

*Self-draining piston
PTC-Push-to-Connect fittings

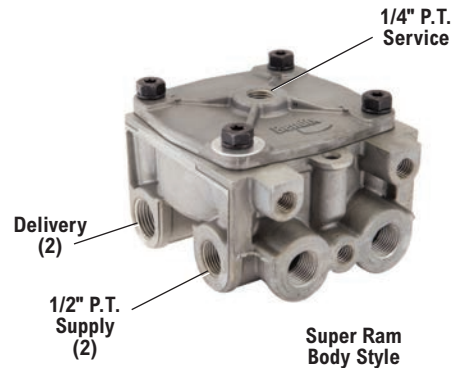

Bendix® R-12® Relay Valves (cont'd)

Two (2) Vertical & Horizontal Delivery Ports

Service New Pc. No.	Crack Pressure (psi)	Delivery Port Size	Maint. Kit	Mounting Bracket
065206	5.5	3/8" P.T.	102802N	296010N
065303	4	3/8" P.T.	102802N	296010N
800095	4	3/8" P.T.	102802N	102846N**
800441	5.5	3/8" P.T.	102802N	102846N**
800483	5.5	1/2" P.T.	102802N	N/A
800484	5.5	1/2" P.T.	102802N	296010N
800485	4	1/2" P.T.	102802N	N/A
800486	4	1/2" P.T.	102802N	296010N
800508	5.5	1/2" P.T.	102802N	N/A

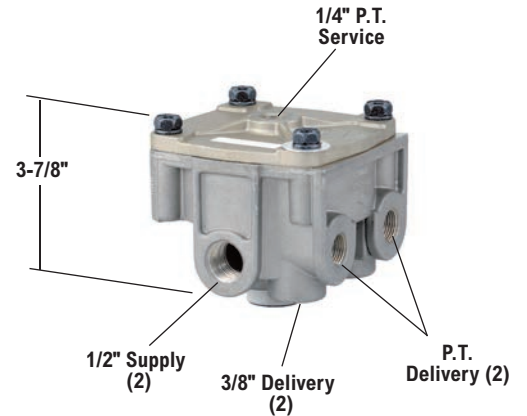

**Mounting bracket 102846N includes two 5/16" mounting studs.
PTC-Push-to-Connect fittings

Bendix® R-12P™ Pilot Relay Valve

- Available Remanufactured Exchange
- Universal Mounting Bracket 296010 included
- Field Maintenance Kit 109265

V.M.R.S. 13-010-009

[SD-03-1063](#)

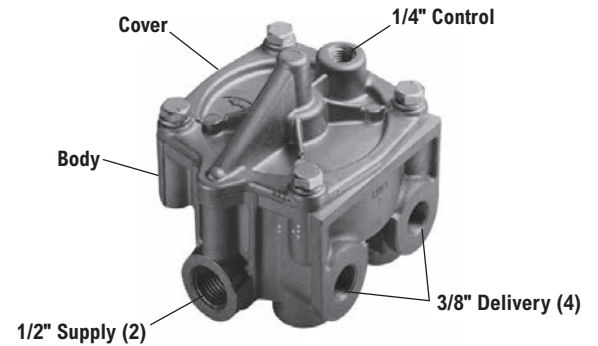

Service New Pc. No.	Reman. Exch. Pc. No.	Delivery (P.T.)	Comments
065476	109264X	3/8"	
801742	—	1/2"	Super Ram Body Style

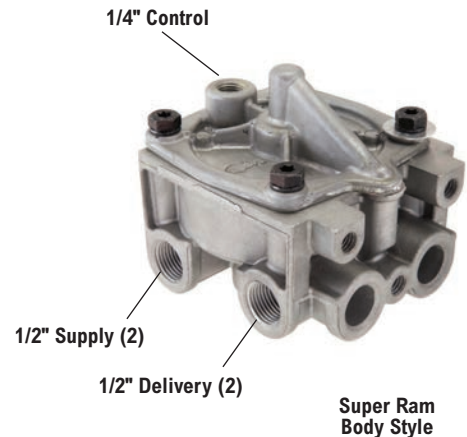

Bendix® R-12DC® Relay Valve with Biased Double Check

SD-03-1068

Bendix® R-12DC® Relay Valve with Two (2) Horizontal Delivery Ports

Service New Pc. No.	Crack Pressure PSI	Supply Ports NPT	Delivery Ports NPT	Bracket Pc. No. (Included)
800470	4	1/2"	1/2"	296010N
800471	5.5	1/2"	1/2"	294649N
800627	4	1/2"	1/2"	294649N

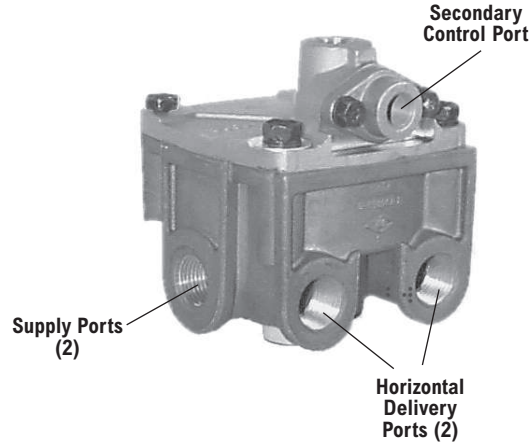

Bendix® R-12DC® Relay Valve with two (2) Horizontal and two (2) Vertical Delivery Ports

Service New Pc. No.	Crack Pressure PSI	Horizontal Delivery Ports NPT	Vertical Delivery Ports NPT	Bracket Pc. No. (Included)	Comments
800481	4	1/2"	3/8"	None	Mounting Studs
801305	4	1/2"	3/8"	102846N	
801381	5.5	1/2"	3/8"	102846N	
K065767	4	1/2"	3/8"	K023876	Bendix® AR1-DC™ valve replacement

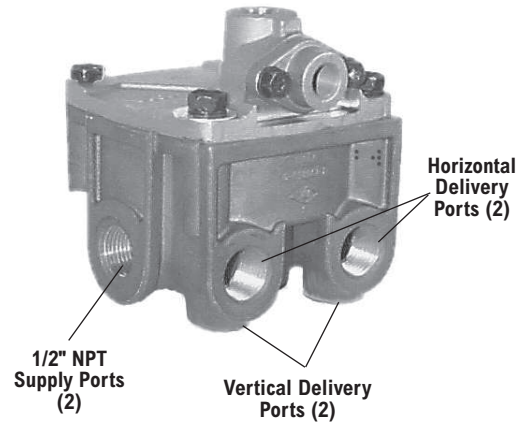

Bendix® R-12DC® Relay Valve with four (4) Vertical Delivery Ports

Service New Pc. No.	Crack Pressure PSI	Vertical Delivery Ports (NPT)	Bracket Pc. No. (Included)
800477	4	1/2"	102846N
800479	4	1/2"	294649N

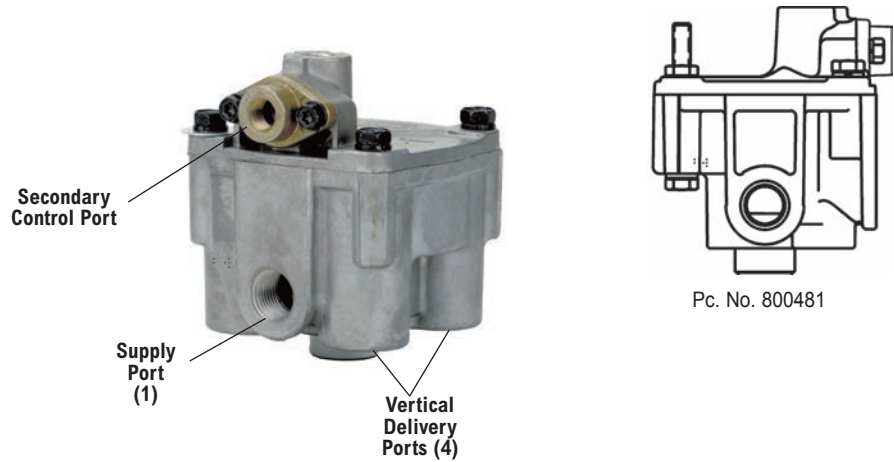

Mounting Bracket Pc. No. 102846N

Mounting Bracket Pc. No. 296010N

Mounting Bracket Pc. No. 294649N

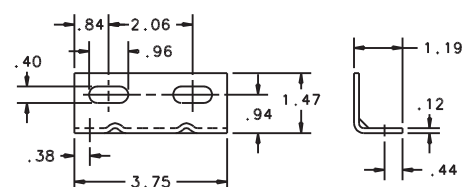
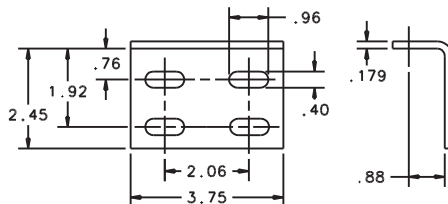
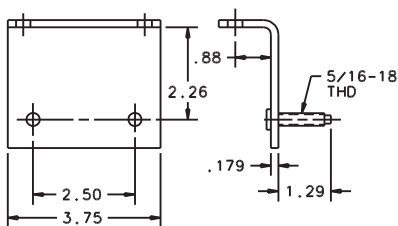

Bendix® R-14® Relay Valve

- Available Remanufactured Exchange
- Field Maintenance Kit for Bendix® R-12® & R-14® Relay Valves is Pc. No. 102802N
- Balance port diaphragm kit - Pc. No. 5011455
- All Universal R-12® and R-14® Relay Valves Include Installation Instructions and a Universal Mounting Bracket Pc. No. 296010N.

V.M.R.S. 13-010-009

SD-03-1064

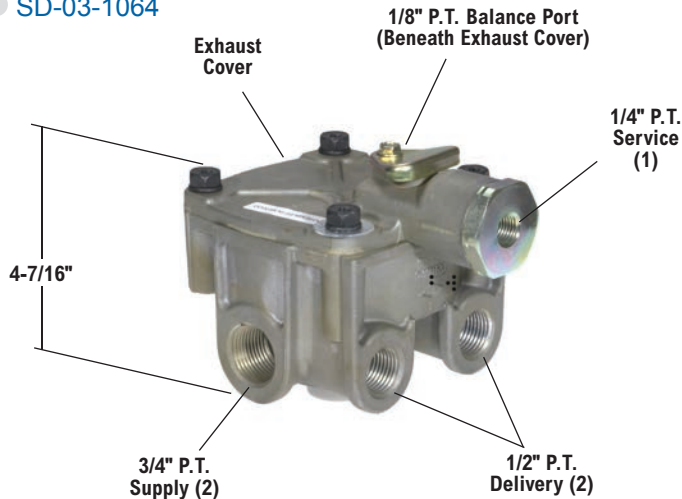

Bendix® R-14® Relay Valve (Horizontal Delivery Ports)

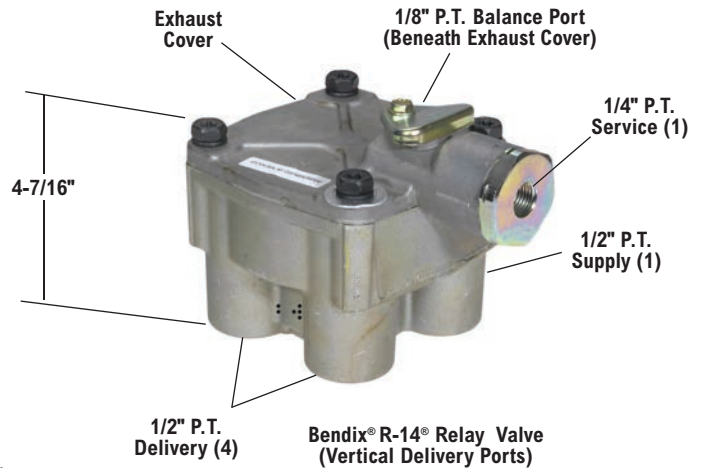
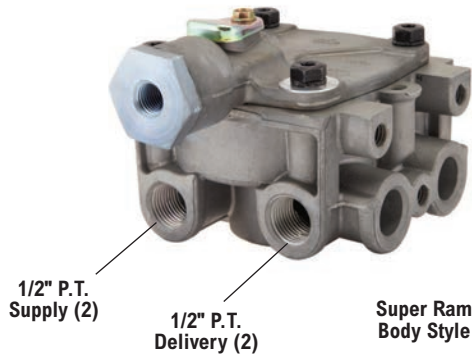

Bendix® R-14® Relay Valve (Vertical Delivery Ports)

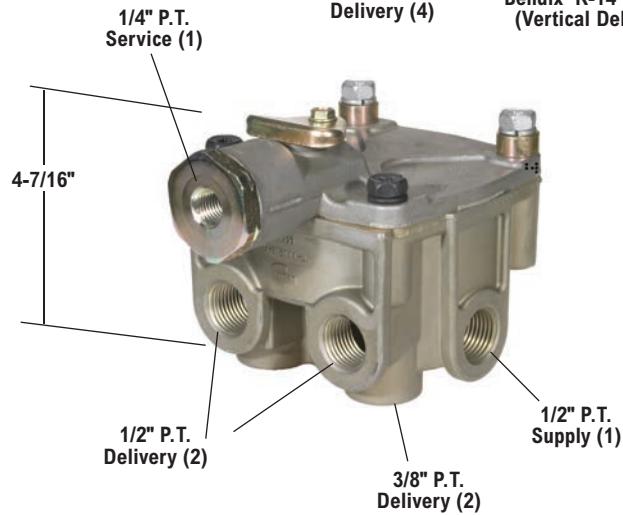

Bendix® R-14® Relay Valve (Horizontal & Vertical Delivery Ports)

Reman. Exchange Pc. No.	Service New Pc. No.	Crack Pressure (psi)	Supply
Horizontal Delivery Ports			
103010RX	103010N	4	3/4"
103294RX	103294N	5.5	3/4"
103835X	103835	7.5	3/4"
-	104345	5	3/4"
104574RX	104574	4	1/2"
-	801629**	4	1/2"
Vertical Delivery Ports			
103028RX	103028N	4	1/2"
-	103833	7.5	1/2"
-	106313	5.5	1/2"
Vertical & Horizontal Delivery Ports*			
-	065430	4	1/2"
-	K065765***	4	1/2"

*Delivery ports two 3/8" & two 1/2"

**Super Ram body style

***Replacement for Bendix® AR-1™ valve

Bendix® RE-6® & RE-6NC™ Relay Emergency Valves

- Available Remanufactured Exchange
- Maintenance Kits:
282812 Complete Valve
282813 Insert Only

V.M.R.S. 13-010-037
 ⓘ [SD-03-1151](#)

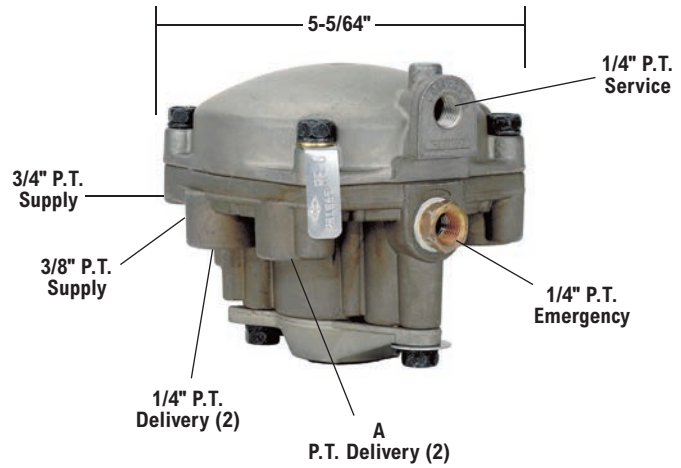

Reman. Exch. Pc. No.	Service New Pc. No.	Valve	A Delivery (P.T.)
281865X	281865	RE-6® Relay Emergency Valve	3/8"
281860X	281860	RE-6 Relay Emergency Valve	1/4"
-	065451	RE-6NC™ Relay Emergency Valve	1/4"

The RE-6NC relay emergency valve must be used in conjunction with a Bendix® PR-3™ reservoir control valve.



Not all reman brake shoes are created equal. In fact, testing shows Bendix® reman brake shoes help you stop more safely – five or more car lengths ahead of the competition. And with our exclusive ProteX™ coatings and high flexural strength friction, Bendix brake shoes extend service life, virtually eliminating rust jacking and cracking. Bendix reman brake shoes. **Now, you know better.**

Discover the difference at safertrucks.com/shoes or call 1.800.AIR.BRAKE (1.800.247.2725) today.



© Bendix Commercial Vehicle Systems LLC, a member of the Knorr-Bremse Group. All Rights Reserved.