

STRONGEST IN THE INDUSTRY

Ankra winches comply with FMCSA, WSTDA-T3 and Canadian Standard 905 regulations. Available in different base configurations to suit a variety of needs and load requirements.

All winches shown are right hand models. Left hand models may be available on special orders.

Black powder coat is the standard finish for all winches.

Smooth ground web slots prevent web wear.

Seamless solid steel mandrel.

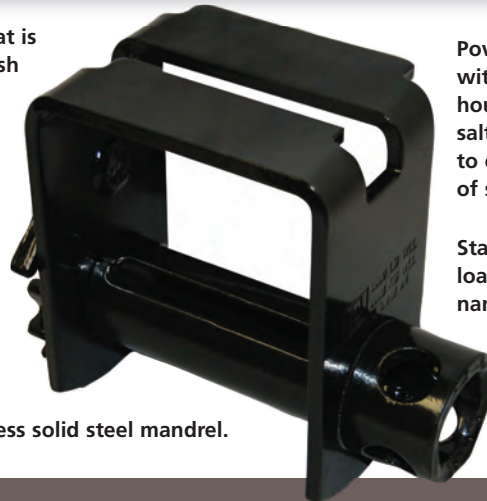

Powder coating withstands 250 hours of standard salt spray testing to ensure years of service.

Stamped working load limit and Ankra name certify quality.

High-strength alloy pawl pins.

WEB WINCHES

Bottom Mount



43563-10
Standard Weld-on
Weight: 8.6 lbs./3.9 kg.
WLL: 5,500 lbs./2,500 kg.



43563-10-RW
Standard Weld-on Ratchet Winch
Weight: 10.1 lbs./4.58 kg.
WLL: 5,500 lbs./2,500 kg.



43564-127
Web Storable Portable w/ 2SS
Weight: 11.1 lbs./5.0 kg.
WLL: 5,500 lbs./2,500 kg.



43564-147
Standard Portable w/ 2SS
Lighter 7mm heat treated frame
Weight: 7.7 lbs./3.5 kg.
WLL: 5,500 lbs./2,500 kg.



43564-147-RW
Standard Portable Ratchet Winch
Lighter 7mm heat treated frame
Weight: 9.2 lbs./4.17 kg.
WLL: 5,500 lbs./2,500 kg.



43564-167
Low Profile Portable w/ 2SS
Weight: 10.1 lbs./4.58 kg.
WLL: 5,500 lbs./2,500 kg.



43573-10
Web Storable Weld-on
Weight: 9.1 lbs./4.1 kg.
WLL: 5,500 lbs./2,500 kg.



43573-13
Web Storable Weld-on 4" Spool
Weight: 12.4 lbs./5.6 kg.
WLL: 5,500 lbs./2,500 kg.



48783-10
Weld-on Double Cap
Weight: 9.0 lbs./4.1 kg.
WLL: 5,500 lbs./2,500 kg.

WEB WINCHES

Side Mount Weld-on



43579-20
Low Profile Weld-on
Weight: 7.3 lbs./3.3 kg.
WLL: 5,500 lbs./2,500 kg.



41691-10
Leg Bracket Weld-on
Weight: 7.1 lbs./3.2 kg.
WLL: 5,500 lbs./2,500 kg.

DID YOU KNOW? About Winches

3-BAR: Designed for easy strap insertion during snow and ice conditions. Prevents the mandrel from freezing up.

PORTABLE: Versatile and meant for temporary installation, and can be placed along the trailer side frame.

SPOOL: Designed to reduce strap wear, spool discs guide and store the webbing into a single roll up to 30'.

STANDARD DOUBLE CAP: Incremental adjustment from both sides of the winch allows for clearance applications.

SLIDERS: Allow for easy positioning in the track, but lock into place when tension is applied to the strap. For use with Ankra C track 42357-11, -12 & -21 and Ankra double L track 49242-10-120 & 49789-10-102 or equivalent.

Sliders



43565-127
Web Storable
C Track Slider.
Lighter 7mm heat treated frame
Weight: 8.2 lbs./3.7 kg.
WLL: 6,000 lbs./2,730 kg.



43565-127-RW
Web Storable Bottom Mount
Ratchet Winch
C Track Slider
Lighter 7mm heat treated frame
Weight: 9.7 lbs./4.4 kg.
WLL: 6,000 lbs./2,730 kg.



43565-127-XZ
Web Storable
X-Treme Zinc Finish
C Track Slider
Lighter 7mm heat treated frame
Weight: 8.2 lbs./3.7 kg.
WLL: 6,000 lbs./2,730 kg.



43565-137
Standard Double Cap
C Track Slider. Lighter 7mm heat treated frame
Weight: 8.3 lbs./3.8 kg.
WLL: 6,000 lbs./2,730 kg.



43565-14
Web Storable w/ Side Washers
C Track Slider.
Weight: 8.6 lbs./3.9 kg.
WLL: 6,000 lbs./2,730 kg.

*43565-177 Standard height version also available.



Reduces weight per winch by 2 lbs. on average. Lighter weight reduces fuel expenses and allows for a greater payload. Heat treated material maintains strength.

WEB WINCHES

Sliders



43565-157
Standard Bottom Mount
C Track Slider. Lighter 7mm heat
treated frame
Weight: 7.6 lbs./3.5 kg.
WLL: 6,000 lbs./2,730 kg.



43565-157-RW
Standard Ratchet Winch
C Track Slider
Lighter 7mm heat treated frame
Weight: 9.1 lbs./4.1 kg.
WLL: 6,000 lbs./2,730 kg.



43565-157-XZ
Standard Bottom Mount
X-Treme Zinc Finish
C Track Slider
Lighter 7mm heat treated frame
Weight: 7.6 lbs./3.5 kg.
WLL: 6,000 lbs./2,730 kg.



49207-127
Web Storable
Double L Track Slider
Lighter 7mm heat treated frame
Weight: 6.8 lbs./3.09 kg.
WLL: 5,500 lbs./2,500 kg.



49207-127-RW
Web Storable Ratchet Winch
Double L Track Slider
Lighter 7mm heat treated frame
Weight: 8.3 lbs./3.8 kg.
WLL: 5,500 lbs./2,500 kg.



49207-127-XZ
Web Storable
Double L Track Slider
X-Treme Zinc Finish
Lighter 7mm heat treated frame
Weight: 6.8 lbs./3.1 kg.
WLL: 5,500 lbs./2,500 kg.



49207-137
Standard
Double L Track Slider
Lighter 7mm heat treated frame
Weight: 6.5 lbs./2.95 kg.
WLL: 5,500 lbs./2,500 kg.



49207-137-RW
Standard Ratchet Winch
Double L Track Slider
Lighter 7mm heat treated frame
Weight: 8.0 lbs./3.6 kg.
WLL: 5,500 lbs./2,500 kg.



49207-137-XZ
Standard
Double L Track Slider
X-Treme Zinc Finish
Lighter 7mm heat treated frame
Weight: 6.5 lbs./2.3 kg.
WLL: 5,500 lbs./2,500 kg.



To give your winches a longer working life, specify X-Treme Zinc for better corrosion protection than zinc-plated, paint or powder coated finishes.

WEB WINCHES

Sliders



49207-187
Low Profile
Double L Track Slider
Lighter 7mm heat treated frame
Weight: 6.2 lbs./2.8 kg.
WLL: 5,500 lbs./2,500 kg.



49207-187-RW
Low Profile Ratchet Winch
Double L Track Slider
Lighter 7mm heat treated frame
Weight: 7.7 lbs./3.5 kg.
WLL: 5,500 lbs./2,500 kg.



49207-187-XZ
Low Profile
Double L Track Slider
X-Treme Zinc Finish
Lighter 7mm heat treated frame
Weight: 6.2 lbs./2.8 kg.
WLL: 5,500 lbs./2,500 kg.



49706-10
Standard
Wilson Track Slider
Weight: 12.5 lbs./5.7 kg.
WLL: 5,500 lbs./2,500 kg.



49706-11
Low Profile
Wilson Track Slider
Weight: 11.5 lbs./5.2 kg.
WLL: 5,500 lbs./2,500 kg.



49246-10-BP
Standard
Utility Trailer Track Slider
Weight: 13 lbs./5.9 kg.
WLL: 5,500 lbs./2,500 kg.



RATCHETING WINCHES

Faster and more convenient than traditional winches. Reduces the tensioning time by 33%. Also, reduces risk of winch bar rollover. Once the winch bar tip is inserted into the winch cap, the winch can be fully tensioned without the need to repetitively remove and reposition the winch bar.

LOOSE TIE DOWNS?

Even with enough tie downs in place, if any are loose or defective, you could get a citation.

WEB WINCHES

3-Bar

Weld-on and 3-Bar winches are available in various finishes, including X-Treme Zinc.



48101-103
3-Bar Weld-on
Side Mount
Weight: 9.5 lbs./4.3 kg.
WLL: 6,000 lbs./2,730 kg.



48101-103-XZ
3-Bar Weld-on
Side Mount
X-Treme Zinc Finish
Weight: 9.5 lbs./4.3 kg.
WLL: 6,000 lbs./2,730 kg.

DID YOU KNOW?
Portable and slider winches are engineered to be placed anywhere along side the trailer as needed to best secure the load.



48101-133
3-Bar Low Profile Weld-on
Bottom Mount
Weight: 9.6 lbs./4.4 kg.
WLL: 6,000 lbs./2,730 kg.



48101-143
3-Bar Standard Weld-on
Bottom Mount
Weight: 11.3 lbs./5.1 kg.
WLL: 6,000 lbs./2,730 kg.



48101-163-XZ
3-Bar Standard Portable
w/ 2 Set Screws
X-Treme Zinc Finish
Weight: 11.2 lbs./5.1 kg.
WLL: 6,000 lbs./2,730 kg.



48101-173
3-Bar Standard
C Track Slider
Weight: 10.4 lbs./4.7 kg.
WLL: 6,000 lbs./2,730 kg.



49207-273
3-Bar Standard
Double L Track Slider
Weight: 8.7 lbs./3.9 kg.
WLL: 5,500 lbs./2,500 kg.



49207-273-XZ
3-Bar Standard
Double L Track Slider
X-Treme Zinc Finish
Weight: 8.7 lbs./3.9 kg.
WLL: 5,500 lbs./2,500 kg.

49207-283-XZ
3-Bar Low Profile
Double L Track Slider
X-Treme Zinc Finish
Weight: 9.2 lbs./4.2 kg.
WLL: 5,500 lbs./2,500 kg.



Introducing Ancra's new bolt-on side mount 3-Bar winch. All Ancra 3-bar winches comply with FMCSA, WSTDA-T3 and Canadian Standard 905 regulations.

49997-113 **NEW**
3-Bar Side Mount Bolt-on
Lighter 7mm heat treated frame
Weight: 9.8 lbs./4.4 kg.
WLL: 5500 lbs./2500 kgs



COMBINATION WEB/CABLE WINCHES

Ancra Combination Winches are made in a variety of configurations to fit applications that require cable or webbing tie downs.



41681-10
Standard Bottom Mount
Weight: 10.6 lbs./4.8 kg.
WLL: 5,500 lbs./2,500 kg.



43488-20
Low Profile Side Mount
Weight: 10.9 lbs./4.9 kg.
WLL: 5,500 lbs./2,500 kg.



43908-10
Recessed Box
Weight: 12.9 lbs./5.9 kg.
WLL: 5,500 lbs./2,500 kg.



43997-10
Low Profile Leg Bracket
Weight: 8.7 lbs./3.9 kg.
WLL: 5,500 lbs./2,500 kg.

CABLE WINCH

For cable applications, Ancra offers these popular models. Your cable selection must be consistent with your cable manufacturer's safe working load ratings.



END MOUNT

41696-10
End Mount RH
Weight: 15.4 lbs./7.0 kg.
WLL: 5,500 lbs./2,500 kg.

41696-11
End Mount LH
Weight: 15.4 lbs./7.0 kg.
WLL: 5,500 lbs./2,500 kg.



'TRUCKER TIP'

CARGO THAT IS NOT BLOCKED MUST HAVE AT LEAST 2 TIE DOWNS IN THE FIRST 10 FEET AND ONE ADDITIONAL TIE DOWN FOR EACH ADDITIONAL 10 FEET OR FRACTION THEREOF. FOR COMPLETE INFORMATION, REFER TO THE FMCSA AND OR CANADIAN REGULATIONS.

LASHING WINCHES

The lashing winch with double hex drive can be bolted or welded to the trailer like a standard winch, yet offers the quick release and easy operation of a ratchet buckle.



47640-31

With double hex drive and three mounting holes.
Weight: 3.8 lbs./1.7 kg.
WLL: 3,333 lbs./1,515 kg.

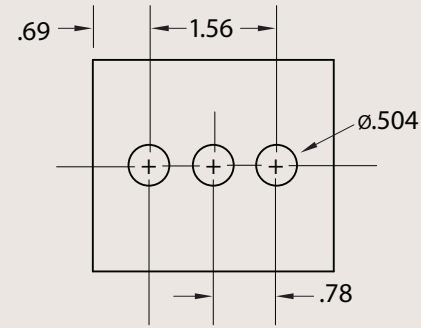

48496-11

With double hex drive, release latch, and single mounting hole.
Weight: 2.2 lbs./1 kg.
WLL: 2,500 lbs./1,135 kg.

WINCH MAINTENANCE

Though winches don't actually come in contact with the load, their function of tightening and anchoring the webbing or cable is critical to the security of over-the-road cargo hauling.

INSPECTION

To insure winches will perform, a quick inspection before each use will assure they are undamaged and working properly. Damaged or non-operational winches should be replaced immediately.

CARE

For optimum performance, winches should be cleaned to remove dirt, mud, road salt, and ice. Lubrication ensures that gravity will allow the winch pawl to drop freely into the sprocket teeth, and the sprocket will rotate freely. When not in use, portable winches should be cleaned and stored in a dry location. With a little care, your winches will go a long way.

PORTAWINCH® AND PORTANCHOR®

PATENTED

Turn stake pockets into strap anchor points.

Ankra has created a way you can turn standard stake pockets into solid anchor points for securement straps. Our FMCSA compliant 3-Bar PortaWinch and PortaAnchor offer a versatile system that allows you to position the tie down straps anywhere along either side, front or back of the trailer, using stake pockets that best accommodate your load.

- ▶ Fasten straps securely and in compliance with federal regulations.
- ▶ Working Load Limit (WLL) 5,500 lbs./ 2,495 kg.
- ▶ For use with standard winch straps and tensions with standard winch bar.
- ▶ Fits all standard stake pockets. Will not fit tapered stake pockets.
- ▶ Installs easily without tools.
- ▶ Works over tires and toolboxes.
- ▶ Removable when not in use.



Installs easily with patented spring-loaded front hook design that distributes the load evenly across the stake pocket. Cap has four holes and accommodates standard winch bars.

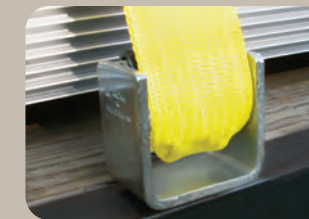

PortaAnchor accepts straps with flat hooks and straps with chain anchors.

PORTAWINCH® PATENTED

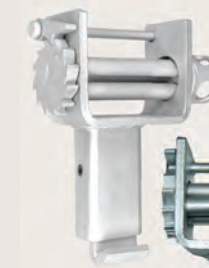

49716-10

Standard outward off-set.
Weight: 11.5 lbs./5.2 kg. WLL: 5,500 lbs.



49716-10-RW

Ratcheting PortaWinch
Standard outward off-set.
Weight: 13.2 lbs./5.9 kg. WLL: 5,500 lbs.

49716-11

Inward off-set to allow for track-mounted tarp clearance.
Weight: 11.5 lbs./5.2 kg. WLL: 5,500 lbs.

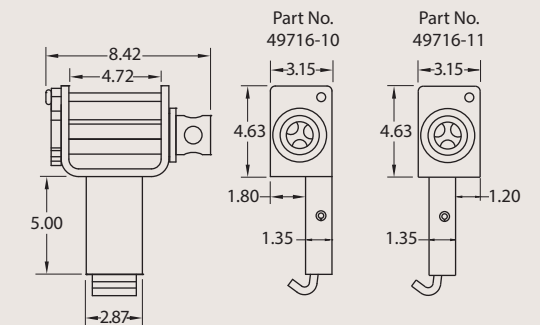

PORTANCHOR® PATENTED



49717-10

Standard outward off-set.
Weight: 9.5 lbs./4.3 kg.
WLL: 5,500 lbs.

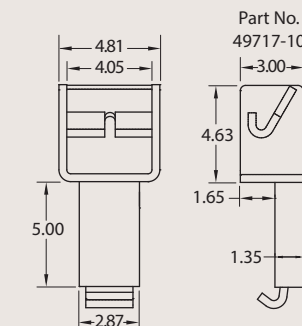

Flat Hook Application



Chain Anchor Application

SILVERCAP OVERDRIVE® RATCHETING CAP

PATENTED

Convert any winch into a ratcheting winch by adding Ankra's OverDrive Ratcheting Cap. The OverDrive Ratcheting Cap has been re-engineered to feature the enhanced ratcheting mechanism employed by all Ankra Ratcheting Winches. Benefits of the OverDrive Ratcheting Cap include an easy access grease fitting for maintaining effortless function and ease of installation onto standard winches using the hardware provided. The patented design includes internal seals to keep out moisture and road grime so an outer rubber sleeve is no longer needed. Your winch bar stays in the winch until your straps are tight. For more information about Ankra's one-year product warranty, please call Customer Service at 800-233-5138.

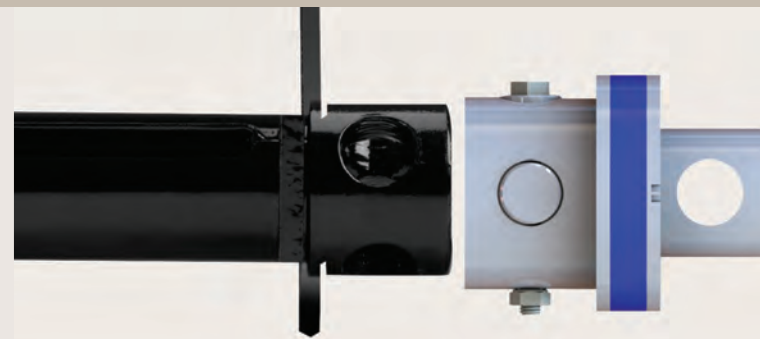

SilverCap
OverDrive®



49723-10
Weight: 3.45 lbs./1.56 kg.

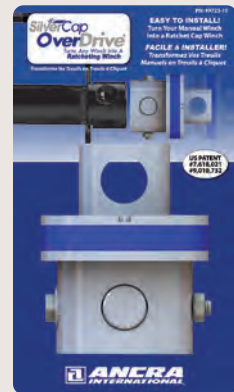

Ankra's OverDrive® is the easy upgrade for winches. With a ratcheting winch, you work faster because the winch bar stays in the winch until the strap is tight.

To install on any winch:

1. Simply slide the OverDrive unit over the cap of the existing winch.
2. Rotate cap to line up holes and insert pin.
3. Secure it with the bolt.

It's that simple. All necessary parts are included.

Assembly Diagram Schéma de Montage

Lubrication: Periodically add lubricant through grease fitting to maintain ratchet function. Use needle adapter on grease gun. Shell Gadus S2 V100 is recommended. **DO NOT OVERFILL.**

Lubrification : Ajouter périodiquement du lubrifiant graisseur pour maintenir la fonction de cliquet. Utilisez un adaptateur d'aiguille sur le pistolet graisseur. Shell Gadus S2 V100 est recommandé. **NE PAS TROP REMPLIR.**

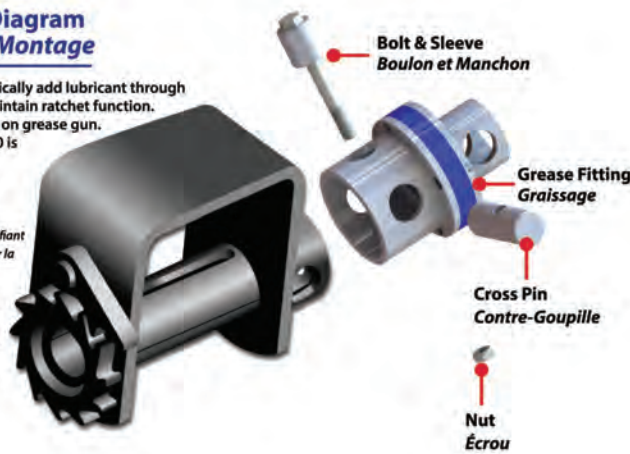

FLATBED ACCESSORIES

ERGO 360° Winch Bars

PATENTED



ErgoBar®
A NEW ANGLE
ON THE WINCH BAR®

See what a difference a bend in the bar makes.

The Ergo 360° Bar takes Ankra's winch bars to the next level. The patented ergonomic design maintains parallel alignment of handle and tip, so you can rotate the bar for optimum leverage without removing it, and keep it secured in the winch cap through the mushroom tip. Easy to carry, easy to handle, the Ergo 360° Bar is the most efficient and economical new tool you'll use. Available in standard, combination and combination box end models. Combination winch bars can be used to release tension on chain binders. Use caution to avoid injury. Not to be used as a cheater bar.



50015-10
Standard Painted.
Weight: 5.0 lbs./2.27 kg.



50015-20
Combination Painted.
Weight: 6.5 lbs./2.95 kg.



50015-21
Combination Box End Painted.
Weight: 6.0 lbs./2.72 kg.



Learn how this uniquely designed winch bar prevents injuries.

Scan this QR Code to watch the video or go to our website at <https://www.ancracargo.com/product-category/flatbed-solutions/winch-bars/ergo-360-winch-bars/>

FLATBED ACCESSORIES

Standard Winch Bars

Tapered and angled at the end for easy operation, Ancra's winch bar handles are knurled at two sections, and the mushroom tip helps keep the bar from slipping from the winch cap. They are heat-treated for extra strength and cycle tested to simulate years of heavy use. Combination winch bars can be used to release tension on chain binders. Use caution to avoid injury. Not to be used as a cheater bar.

Flanged mushroom tip helps keep the bar from slipping from the winch cap.



42313-10
Standard Painted. Weight: 5.0 lbs./2.27 kg.



42313-17
Standard Chrome. Weight: 5.0 lbs./2.27 kg.



42313-19
Combination Chrome. Weight: 6.5 lbs./2.95 kg.



42313-12
Combination Box End Painted Silver and Yellow. Weight: 6.5 lbs./2.95 kg.

Heavy Duty D-Rings



Rugged forged steel D-Rings add versatility for securing complex loads. Utility trailers typically use 1/2 and 5/8 inch models, while heavy-duty applications rely on the 3/4 and 1-inch sizes. Individually polybagged.

49896-10 1/2" Forged steel w/ Bolt-on clip Wt: 1.0 lbs./0.50 kg. WLL: 4,000 lbs.	49896-11 1/2" Forged steel w/ Weld-on clip Wt: 1.0 lbs./0.50 kg. WLL: 4,000 lbs.	49897-10 5/8" Forged steel w/ Weld-on clip Wt: 1.9 lbs./0.86 kg. WLL: 6,300 lbs.	49898-10 3/4" Forged steel w/ Weld-on clip Wt: 2.2 lbs./1.0 kg. WLL: 9,000 lbs.	49899-10 1" Forged steel w/ Weld-on clip Wt: 4.4 lbs./2.0 kg. WLL: 15,600 lbs.	49899-11 NEW 1" Forged Bent D-Ring Assembly w/ Weld-on clip. Wt: 4.8 lbs./2.1 kg. WLL: 15,600 lbs.
--	--	--	---	--	--

FLATBED ACCESSORIES

Hooks & Web Winders

44102-11
H-2 Hook. Flame-cut from 5/8-in. material and can be welded on vehicles. Accepts web loops, D-Rings, cable or rope. Meets anchorage requirements when properly secured. Hook opening .81" Weight: .61 lb./ .28 kg. WLL: 5,400 lbs./2,450 kg.

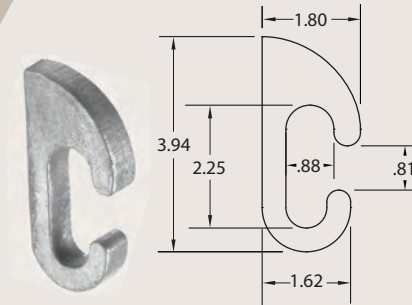

44122-10
Corner Iron Hook
Constructed with no sharp corners to reduce abrasion to rope or cable. Weight: .63 lb./0.29 kg.



50024-10
Tarp Hook. For securing tarp straps to trailers. 1/2-in. steel wire. Unfinished light oil. Weight: .39 lb./0.18 kg.

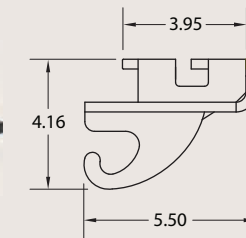

49768-10
Double L Track Slider Hook
Black powder coat finish. Hook opening .71" Weight: 5.65 lbs./2.57 kg. WLL: 5,500 lbs./2,500 kg.



50092-10
EZ Winder Strap Winder quickly and easily winds webbing onto your winch for storage. Weight: 1.1 lbs./0.5 kg.

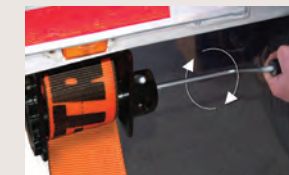

45801-10
Web Winder. Constructed of all steel, the Ancra Web Winder winds 2-in., 3-in. and 4 in. winch straps for compact storage. Easy to attach to vehicle rails, easy to remove with tapered forks, and easy to disassemble for storage. Weight: 3.25 lbs./1.48 kg.

50391-10
Premium Cargo Strap Winder
Constructed of zinc-plated steel for maximum durability, the new Strap Winder quickly assists in winding winch straps into rolls for storage. Designed to clip into trailer stake pocket or side rail. Weight: 2.7 lbs./1.2 kg.



Heavy Duty Strap Storage Band

Keep stored straps from unrolling with our 1-inch by 7-inch long storage bands. Made of natural rubber, the storage bands are tough and easy-to-use at low temperatures.

NEW 50433-10 Pack of 5



ANCRA X-TREME™ WEBBING PERFORMANCE LEADER

As the name implies, Ancra's X-TREME webbing offers our greatest performance, durability, strength and abrasion resistance. Because of its special weave construction and coating process, X-TREME realizes an impressive 80% minimum retained strength after abrasion testing, as opposed to 40% for standard webbing. X-TREME's coating is durable and permanent, and reduces water absorption and freezing. Ancra X-TREME is available in popular winch and ratchet strap models that meet or exceed WSTDA T-1 standards. Custom lengths and end hardware quoted upon request.



ANCRA X-TREME™ WINCH STRAP ASSEMBLIES

Custom lengths and webbing configurations available.

2" WINCH STRAPS — WLL: 3,333 lbs./1,515 kg. using 41632-37 X-TREME Webbing



41659-90-27
2-in. x 27-ft. ANCRA X-TREME Strap w/ 40891-18 Flat Hook

41659-90-30
2-in x 30-ft. ANCRA X-TREME Strap w/ 40891-18 Flat Hook



41659-92-30
2-in x 30-ft. ANCRA X-TREME Strap w/ 43120-13 Wire Hook



41659-93-30
2-in x 30-ft. ANCRA X-TREME Strap w/ 43366-21 Chain Anchor



41659-94-30
2-in x 30-ft. ANCRA X-TREME Strap w/o hardware. For winch to winch applications. Custom lengths available.



ANCRA X-TREME™ WINCH STRAP ASSEMBLIES

3" WINCH STRAPS — WLL: 5,400 lbs./2,450 kg. using 41632-38 X-TREME Webbing



41660-90-30
3-in. x 30-ft. ANCRA X-TREME Strap w/ 41766-18 Flat Hook



41660-93-30
3-in. x 30-ft. ANCRA X-TREME Strap w/ 43366-14 Chain Anchor



41660-95-30
3-in. x 30-ft. ANCRA X-TREME Strap w/o hardware. For winch to winch applications. Custom lengths available.

ANATOMY OF A WINCH STRAP

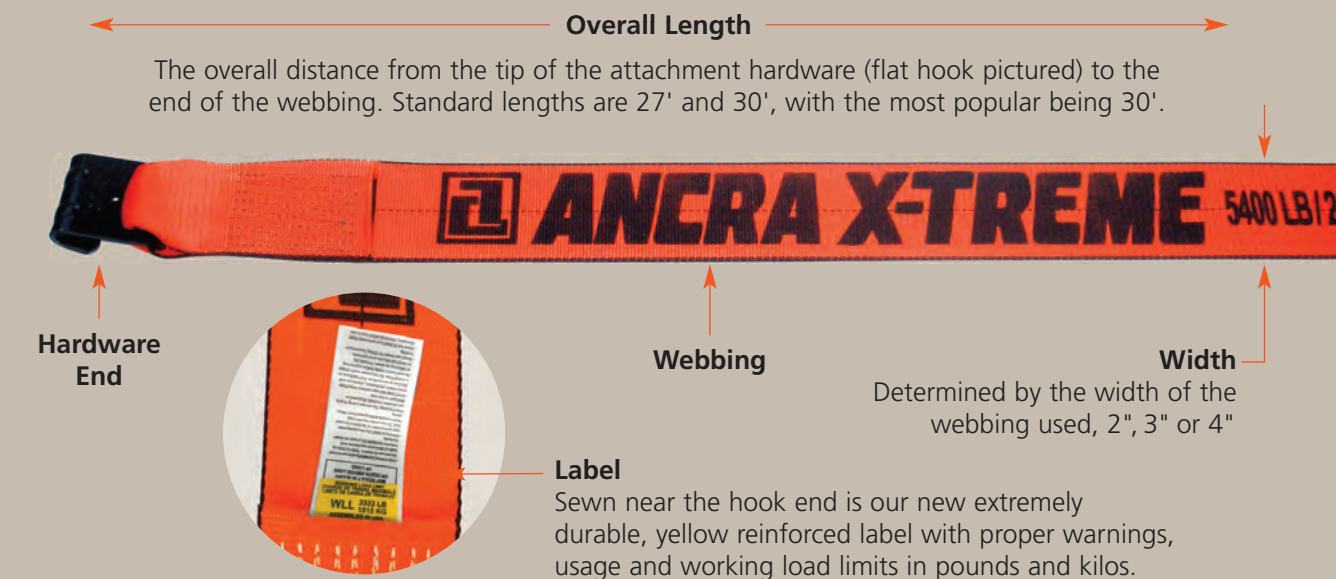

ANCRA X-TREME™ WINCH STRAP ASSEMBLIES

4" WINCH STRAPS — WLL: 5,400 lbs./2,450 kg. using 43797-37 X-TREME Webbing



43795-90-27

4-in. x 27-ft. ANCRA X-TREME Strap w/ 41766-18 Flat Hook

43795-90-30

4-in. x 30-ft. ANCRA X-TREME Strap w/ 41766-18 Flat Hook

43795-90-40

4-in. x 40-ft. ANCRA X-TREME Strap w/ 41766-18 Flat Hook

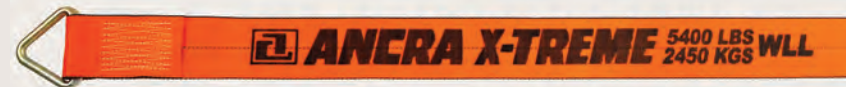

43795-91-27

4-in. x 27-ft. ANCRA X-TREME Strap w/ 41631-12 Delta Ring

43795-91-30

4-in. x 30-ft. ANCRA X-TREME Strap w/ 41631-12 Delta Ring

43795-91-40

4-in. x 40-ft. ANCRA X-TREME Strap w/ 41631-12 Delta Ring



43795-93-30

4-in. x 30-ft. ANCRA X-TREME Strap w/ Half Twisted Loop



43795-95-30

4-in. x 30-ft. ANCRA X-TREME Strap w/ 43366-14 Chain Anchor



43795-92-30

4-in. x 30-ft. ANCRA X-TREME Strap w/o hardware. For winch to winch applications. Custom lengths available.

MILE AFTER MILE, YOUR DEPENDABLE CLASSIC.

Ancra Winch Strap Assemblies combine heavy-duty, wear and weather resistant latex treated polyester webbing with strong, dependable hardware to meet the demanding conditions of flatbed operations. Ancra straps meet FMCSA and CCMTA specifications and are tested for strength and durability. Meets or exceeds WSTDA T-1 Recommended Standard Specifications for synthetic web tie downs.



WINCH STRAP ASSEMBLIES

2" WINCH STRAPS — WLL: 3,333 lbs./1,515 kg. using 41632-46 Webbing



41659-10-27

2-in. x 27-ft. Winch Strap w/ 40891-18 Flat Hook

41659-10-30

2-in. x 30-ft. Winch Strap w/ 40891-18 Flat Hook



41659-11-27

2-in. x 27-ft. Winch Strap w/ 40978-11 Delta Ring

41659-11-30

2-in. x 30-ft. Winch Strap w/ 40978-11 Delta Ring



41659-13-27

2-in. x 27-ft. Winch Strap w/ 43120-13 Wire Hook

41659-13-30

2-in. x 30-ft. Winch Strap w/ 43120-13 Wire Hook



41659-15-27

2-in. x 27-ft. Winch Strap w/ 43366-21 Chain Anchor

41659-15-30

2-in. x 30-ft. Winch Strap w/ 43366-21 Chain Anchor



41659-16-30

2-in. x 30-ft. Winch Strap w/o hardware for winch to winch application. Custom lengths available.

WINCH STRAP ASSEMBLIES

3" WINCH STRAPS — WLL: 5,400 lbs./2,450 kg. using 41632-14 Webbing



41660-10-27
3-in. x 27-ft. Winch Strap w/
41766-18 Flat Hook

41660-10-30
3-in. x 30-ft. Winch Strap w/
41766-18 Flat Hook



41660-14-27
3-in. x 27-ft. Winch Strap w/
43366-14 Chain Anchor

41660-14-30
3-in. x 30-ft. Winch Strap w/
43366-14 Chain Anchor



41660-18-27
3-in. x 27-ft. Winch Strap w/
43120-20 Wire Hook

41660-18-30
3-in. x 30-ft. Winch Strap w/
43120-20 Wire Hook



41660-17-30
3-in. x 30-ft. strap w/o hardware for winch to winch application.
Custom lengths available.

4" WINCH STRAPS — WLL: 5,400 lbs./2,450 kg. using 43797-12 Webbing



43795-10-27
4-in. x 27-ft. Winch Strap w/
41766-18 Flat Hook

43795-10-40
4-in. x 40-ft. Winch Strap w/
41766-18 Flat Hook

43795-10-30
4-in. x 30-ft. Winch Strap w/
41766-18 Flat Hook

43795-10-50
4-in. x 50-ft. Winch Strap w/
41766-18 Flat Hook

43795-10-35
4-in. x 35-ft. Winch Strap w/
41766-18 Flat Hook



43795-11-27
4-in. x 27-ft. Winch Strap w/
41631-12 Delta Ring

43795-11-40
4-in. x 40-ft. Winch Strap w/
41631-12 Delta Ring

43795-11-30
4-in. x 30-ft. Winch Strap w/
41631-12 Delta Ring

43795-11-50
4-in. x 50-ft. Winch Strap w/
41631-12 Delta Ring

43795-11-35
4-in. x 35-ft. Winch Strap w/
41631-12 Delta Ring



43795-13-30
4-in. x 30-ft. Winch Strap w/
Half Twisted Loop

43795-13-65
4-in. x 65-ft. Winch Strap w/
Half Twisted Loop

43795-13-45
4-in. x 45-ft. Winch Strap w/
Half Twisted Loop

43795-13-75
4-in. x 75-ft. Winch Strap w/
Half Twisted Loop

43795-13-50
4-in. x 50-ft. Winch Strap w/
Half Twisted Loop



43795-14-27
4-in. x 27-ft. Winch Strap w/
43365-12 Grab Hook

43795-14-30
4-in. x 30-ft. Winch Strap w/
43365-12 Grab Hook

WINCH STRAP ASSEMBLIES

4" WINCH STRAPS — WLL: 5,400 lbs./2,450 kg. using 43797-12 Webbing



43795-15-27
4-in. x 27-ft. Winch Strap w/
43366-14 Chain Anchor

43795-15-30
4-in. x 30-ft. Winch Strap w/
43366-14 Chain Anchor



43795-19-30
4-in. x 30-ft. Winch Strap w/o hardware for winch to winch application. Custom lengths available.



43795-40-30
4-in. x 30-ft. Winch Strap w/ 41766-18 Flat Hook.
using 43797-19 Blue Webbing.



43795-60-30
4-in. x 30-ft. Winch Strap w/ 41766-18 Flat Hook.
using 43797-23 Crimson Red Webbing.

ROLL-ON/ROLL-OFF CONTAINER STRAPS

STANDARD



49526-10
4-in. x 5-ft. Strap w/ 48968-11 Container Hook.
WLL: 5,400 lbs./2,450 kg.



49526-11
4-in. x 5-ft. Strap w/ 48968-11 Container Hook and Sewn Loop end. WLL: 5,400 lbs./2,450 kg.

ANCRA X-TREME™



49526-90
4-in. x 5-ft. Ankra X-TREME Strap w/ 48968-11 Container Hook.
WLL: 5,400 lbs./2,450 kg.



49526-91
4-in. x 5-ft. Ankra X-TREME Strap w/ 48968-11 Container Hook and Sewn loop end. WLL: 5,400 lbs./2,450 kg.