



W1

## “Normal” Mini-clip

The use of malleable mild steel in the manufacture of the “Normal” mini-clip means that when tightened, the clip adapts perfectly to the hose, clamping firmly but gently.

This clip is recommended for use with gaseous fluids at low pressure.

“Normal” also has many applications in the automotive industry

\* The maximum pressure may vary depending on the type of hose and coupling used.

## “Normal” Mini-clip W1

Application Ø		Part n° W1	r	e	a	b	s	Max. values* Torque (Nm)	Max. values* Pressure (Bars)	Box quantity	Packing
mm	inches										
6	15/64	03010510	M3	5	8,4	9	0,5	0,4	15,0	100	1600
8	5/16	03010528	M3	5	9	9	0,5	0,4	14,0	100	1600
9	23/64	03010536	M4	6	10	10	0,5	1,0	15,0	100	1600
9,5-10	3/8-25/64	03010544	M4	6	10	10	0,5	1,0	14,0	100	1600
10-11	25/64 -7/16	03010552	M4	6	10	10	0,5	1,0	13,0	100	1600
12-13	15/32-33/64	03010560	M4	6	10	10	0,5	1,0	12,5	100	1600
13-14	33/64-35/64	03010579	M4	6	10	10	0,5	1,0	12,5	100	1600
14-15	35/64-19/32	03010587	M4	6	10	10	0,5	1,0	12,0	100	1600
15-17	19/32-43/64	03010595	M4	6	10	10	0,5	1,0	12,0	100	1600
16-18	5/8-45/64	03010608	M4	6	10	10	0,5	1,0	11,5	100	1600
18-20	45/64-25/32	03010616	M4	6	10	10	0,5	1,0	10,5	100	1600
19-21	3/4-53/64	03010624	M4	6	10	10	0,5	1,0	10,5	100	800
20-22	25/32-55/64	03010632	M4	6	10	10	0,5	1,0	10,5	100	800
22-25	55/64-63/64	03010640	M4	6	10	10	0,5	1,0	9,5	100	800
23-26	29/32-1-1/32	03010659	M4	6	10	10	0,5	1,0	9,0	100	800
25-28	63/64-1-7/64	03010667	M4	6	10	10	0,5	1,0	8,5	100	800
26-29	1-1/32-1-9/64	03010675	M4	6	10	10	0,5	1,0	8,5	100	800

**W1 Screw:** 6.6 strength Grey-white Cr3 zinc-plated **Band:** St 02Z (DIN 1.0226) **Nut:** 6 strength white Cr3 zinc-plated.

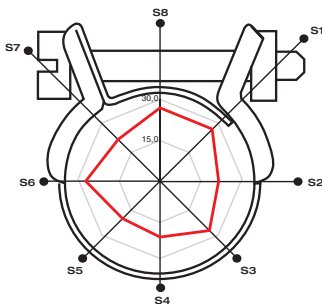

### Polar Diagram

● Sectors	S1	S2	S3	S4	S5	S6	S7	S8
— Force Kg	27,0	21,5	25,6	20,4	19,3	27,2	21,7	26,9

Torque / Efficiency [ Nm / daN ]

