

1.5ME SERIE

- BI-DIRECTIONAL
- SAE-AA 2 BOLT MOUNTING FLANGE
- 1/2 PARALLEL SHAFT
- SAE 04 DRAIN PORT
- * **NEW HIGH PRESSURE SHAFT SEAL AVAILABLE**
CAN GO UP TO 450 PSI COMPARE TO 43 PSI WITHOUT

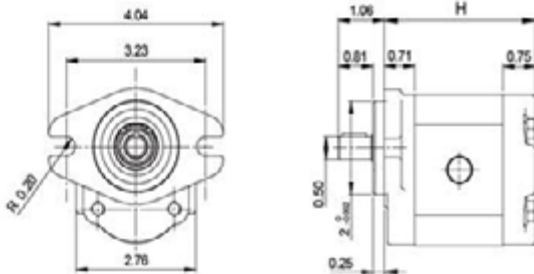

PART NUMBER	DISPLACEMENT IN ³ (CM ³) / REV.	DIMENSION H (IN)	RPM MIN	RPM MAX	MAX PSI	PORT SIZE IN & OUT
610910328	0.17 (2.8)	3.35	700	4500	3625	SAE 8
610911088	0.21 (3.5)	3.42		4500	3625	
610910348	0.25 (4.1)	3.49		4000	3625	
610911098	0.32 (5.2)	3.61		4000	3335	
610910368	0.38 (6.2)	3.72	600	3600	3335	SAE 10
610911108	0.46 (7.6)	3.88		3300	2900	
610910388	0.57 (9.3)	4.07		3000	2610	
610910398	0.67 (11)	4.26		3000	2465	



2ME SERIE

- BI-DIRECTIONAL
- SAE-A 2 BOLT MOUNTING FLANGE
- 5/8" PARALLEL SHAFT
- SAE 04 DRAIN PORT
- * **NEW HIGH PRESSURE SHAFT SEAL AVAILABLE**
CAN GO UP TO 450 PSI COMPARE TO 43 PSI WITHOUT

ALSO AVAILABLE

- OTHER SHAFT DIMENSIONS
- OUTRIGGER BEARING TO ACCEPT SIDE LOAD
- REAR PORT COVER
- INTERNAL DRAIN

PART NUMBER	DISPLACEMENT IN ³ (CM ³) / REV.	DIMENSION H (IN)	RPM MIN	RPM MAX	MAX PSI	PORT SIZE IN & OUT
612095948	0.40 (6.5)	3.64	600	4000	3600	SAE 10
612081668	0.50 (8.3)	3.74	500	3600		
612083618	0.68 (11.3)	4.02		3500		
612084388	0.84 (13.8)	4.17		3400		
612084398	1.01 (16)	4.32	450	3200	3140	SAE 12
612084408	1.15 (19)	4.64		3000	2900	
612084418	1.37 (22.5)	4.86		2850	2600	
612084428	1.58 (26)	5.09				

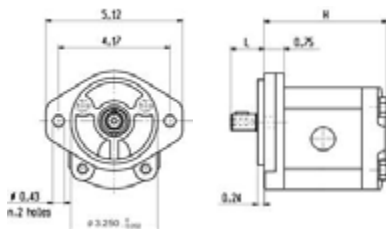

2MGE CAST IRON SERIE

- BI-DIRECTIONAL
- SAE-A 2 BOLT MOUNTING FLANGE
- 5/8" PARALLEL SHAFT
- SAE 04 DRAIN PORT
- * **NEW HIGH PRESSURE SHAFT SEAL AVAILABLE**
CAN GO UP TO 450 PSI COMPARE TO 43 PSI WITHOUT



ALSO AVAILABLE

- OTHER SHAFT DIMENSIONS
- OUTRIGGER BEARING TO ACCEPT SIDE LOAD
- REAR PORT COVER
- INTERNAL DRAIN

PART NUMBER	DISPLACEMENT IN ³ (CM ³) / REV.	DIMENSION H (IN)	RPM MIN	RPM MAX	MAX PSI	PORT SIZE IN & OUT
614670872	1.01 (16)	4.31	450	3200	3600	SAE 10
614670882	1.18 (19)	4.63	450	3200	3140	SAE 12
614670892	1.37 (22.5)	4.85	450	3000	2900	SAE 12
614670902	1.58 (26)	5.08	450	2850	2600	SAE 12

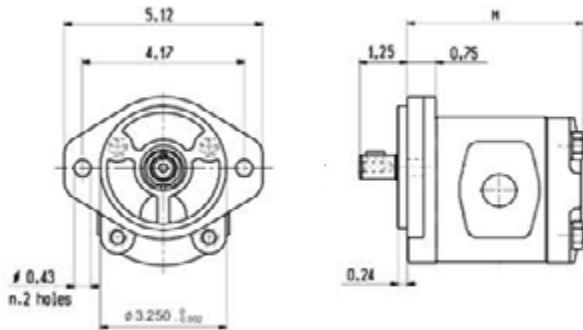

3ME SERIE

- BI-DIRECTIONAL
- SAE-B 2 BOLT MOUNTING FLANGE
- 7/8" PARALLEL SHAFT
- 3/8" BSP DRAIN PORT
- * **NEW HIGH PRESSURE SHAFT SEAL AVAILABLE :**
CAN GO UP TO 450 PSI COMPARE TO 43 PSI WITHOUT



PART NUMBER	DISPLACEMENT IN ³ (CM ³) / REV.	DIMENSION H (IN)	RPM MIN	RPM MAX	MAX PSI	PORT INLET	PORT OUTLET
612978738	1.65 (27)	5.26	600	3000	360	SAE 16	SAE 12
612978748	2.04 (38)	5.46	500				
612978768	2.86 (46)	6.24	400	2750	3500	SAE 20	SAE 16
612978778	3.30 (55)	6.48		2500	3190		

