

MINIMIZER MATERIAL OPTIONS

Minimizer offers a large variety of semi-truck fender styles, colors and material options. With an unmatched reputation of quality, durability, and style; our fenders will enhance your truck's appearance and increase it's lifespan while protecting precious loads and cargo. Our industry leading fender line is manufactured using proprietary composite materials and thermoformed using exclusive technology along with over 35 years of firsthand industry and manufacturing expertise. When dented or crushed Minimizer fenders bounce back into their original shape. The composite materials are extremely durable, impervious to salt and corrosion, and have been tested to withstand temperatures ranging from -100° F to 197° F.

MINIMIZER STANDARD MATERIAL OPTIONS will NEVER NEED PAINT, NEVER FADE, NEVER RUST, AND NEVER CRACK! The color is molded throughout the sheet to hide the the daily abuse of demanding jobsites and unforgiving roads!

MINIMIZER UNIQUE MATERIAL OPTIONS go head-to-head with "shiny metal & custom fiberglass fenders" that will only weigh your truck down and inevitably bend, rust and break! Get the remarkable shine and reflection of metal fenders or the custom aftermarket look, combined with the superior durability of all Minimizer products!

STANDARD MATERIAL OPTIONS



BLACK

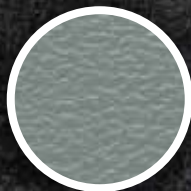

GALVANIZED



RED



WHITE



GREEN



UNIQUE MATERIAL OPTIONS



PAINTABLE



**BLACK
DIAMOND PLATE**



**SILVER
DIAMOND PLATE**

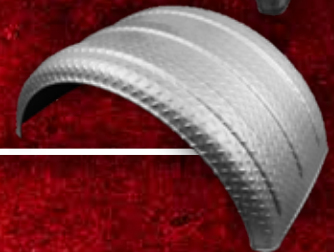

LIQUID PLATIUM



CARBON FIBER



**SILVER
MIRROR FINISH**

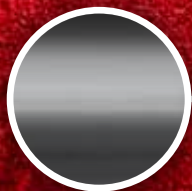

**SMOKY BLACK
MIRROR FINISH**





MIN1600 FENDER SERIES:

THE ONE TON

- MIN1600 is designed to fit a single axle tractor or trailer with 16.5" wheels.
- The set consists of 2 pieces (2 - PM1601 single fenders).
- The total weight of the MIN1600 fender kit is less than 11 lbs.
- See page 38 for complete list of fenders and additional color, material, and lightbox options.
- Visit www.minimizer.com for a fully detailed CADD drawing and individual part numbers by color.



FENDER WIDTH: 20"

MATERIAL OPTIONS

STANDARD



UNIQUE



INSTALLATION KITS

- B100BTPA - Black Plastic Bolt-on Kit
- B100BTSA - Stainless Bolt-on Kit
- B100WOA - Weld-on Kit

See pages 39-46 for more bracket kit information and complete bracket kit listings.



*LIGHT BOX OPTION AVAILABLE

MIN 1900 FENDER SERIES:

LIL' SCRAPPER

- MIN1900 is designed to fit a single axle tractor or trailer with 19.5" wheels.
- The set consists of 2 pieces (2 - PM1901 single fenders).
- The total weight of the MIN1900 fender kit is less than 14 lbs.
- See page 38 for complete list of fenders and additional color, material, and lightbox options.
- Visit www.minimizer.com for a fully detailed CADD drawing and individual part numbers by color.



FENDER WIDTH: 21"

MATERIAL OPTIONS

STANDARD



UNIQUE



INSTALLATION KITS

- B100BTSA - Stainless Bolt-on Kit
- B100BTPA - Black Plastic Bolt-on Kit
- B100W0A - Weld-on Kit

See pages 39-46 for more bracket kit information and complete bracket kit listings.



*LIGHT BOX OPTION AVAILABLE

MIN2260 FENDER SERIES:

THE TTTWIN

- MIN2260 is designed to fit a single, tandem, or multi axle tractor or trailer with 22.5" or 24.5" wheels.
- The set consists of 2 pieces (2 - PM2261 single fenders).
- The total weight of the MIN2260 fender kit is less than 24 lbs.
- See page 38 for complete list of fenders and additional color, material, and lightbox options.
- Visit www.minimizer.com for a fully detailed CADD drawing and individual part numbers by color.



FENDER WIDTH: 25"

MATERIAL OPTIONS

STANDARD



UNIQUE



INSTALLATION KITS

- B100BTPA - Black Plastic Bolt-on Kit
- B100BTPACF - Carbon Fiber Plastic Bolt-on Kit
- #100126 - Mirror Finish Plastic Bolt-on Kit
- B100BTPAPL - Liquid Platinum Plastic Bolt-on Kit
- B100PBA - Plastic Paddle Bracket Bolt-on Kit
- B100BTSA - Stainless Bolt-on Kit
- B100WOA - Weld-on Kit

See pages 39-46 for more bracket kit information and complete bracket kit listings.



*LIGHT BOX OPTION AVAILABLE

MIN2480 FENDER SERIES:

THE TEXAS DOUBLE

- MIN2480 is designed to fit a single, tandem, or multi axle tractor or trailer with 24.5" wheels.
- The set consists of 2 pieces (2 - PM2481 single fenders).
- The total weight of the MIN2480 fender kit is less than 26 lbs.
- See page 38 for complete list of fenders and additional color, material, and lightbox options.
- Visit www.minimizer.com for a fully detailed CADD drawing and individual part numbers by color.



FENDER WIDTH: 25"

MATERIAL OPTIONS

STANDARD



UNIQUE



INSTALLATION KITS

- B100BTPA - Black Plastic Bolt-on Kit
- B100BTPACF - Carbon Fiber Plastic Bolt-on Kit
- #100126 - Mirror Finish Plastic Bolt-on Kit
- B100BTPAPL - Liquid Platinum Plastic Bolt-on Kit
- B100PBA - Plastic Paddle Bracket Bolt-on Kit
- B100BTSA - Stainless Bolt-on Kit
- B100W0A - Weld-on Kit

See pages 39-46 for more bracket kit information and complete bracket kit listings.

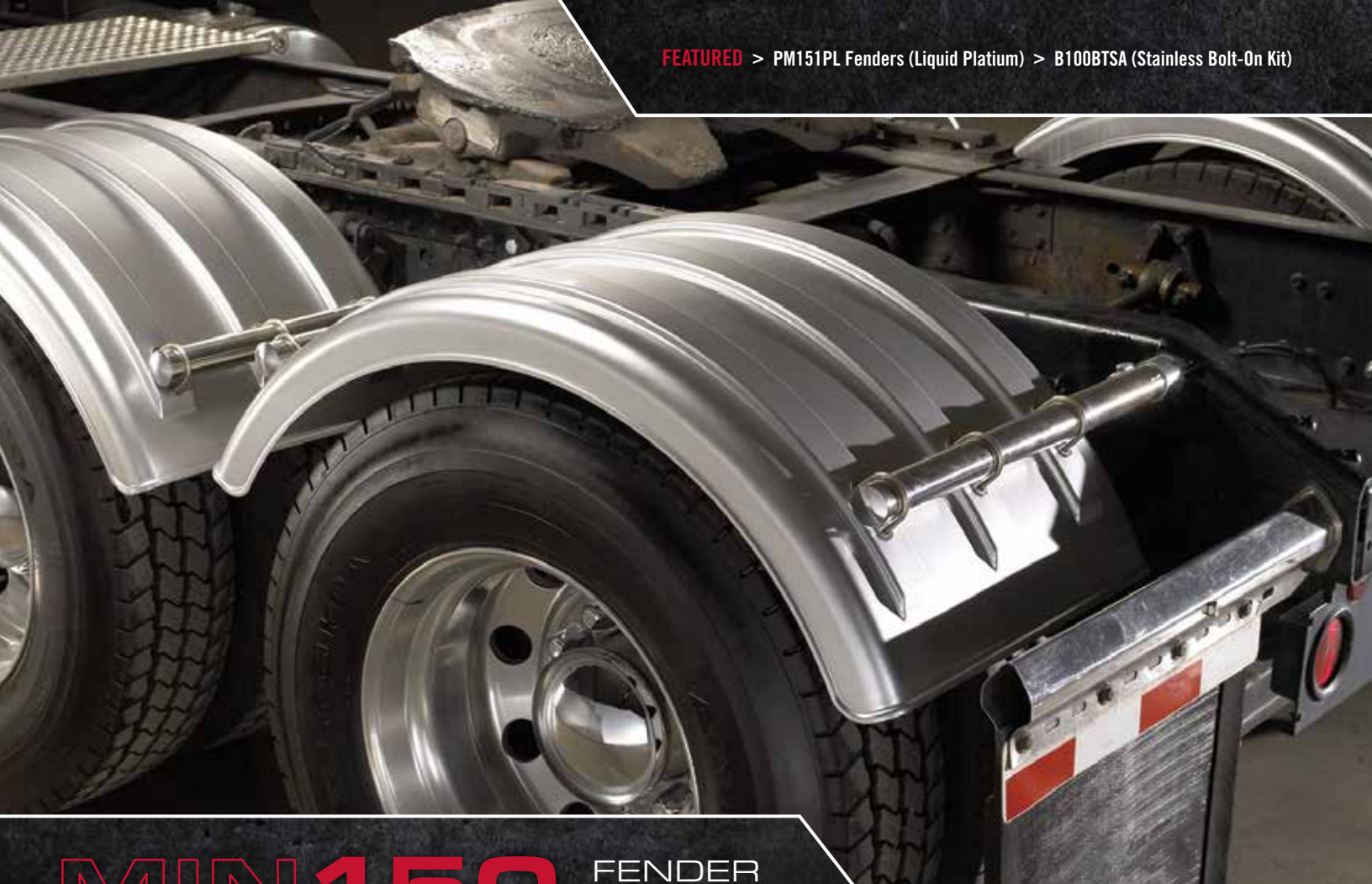

MIN150 FENDER SERIES:

THE EYEBROW

- MIN150 is designed to fit a single, tandem, or multi axle tractor or trailer with 22.5" or 24.5" wheels.
- The set consists of 2 pieces (2 - PM151 single fenders).
- The total weight of the MIN150 fender kit is less than 17 lbs.
- See page 38 for complete list of fenders and additional color, material, and lightbox options.
- Visit www.minimizer.com for a fully detailed CADD drawing and individual part numbers by color.

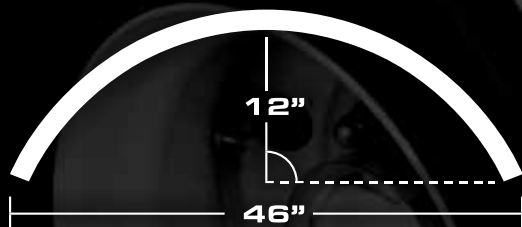

FENDER WIDTH: 26"

MATERIAL OPTIONS

STANDARD



UNIQUE



INSTALLATION KITS

- B100BTPA - Black Plastic Bolt-on Kit
- B100BTPACF - Carbon Fiber Plastic Bolt-on Kit
- #100126 - Mirror Finish Plastic Bolt-on Kit
- B100BTPAPL - Liquid Platinum Plastic Bolt-on Kit
- B100PBA - Plastic Paddle Bracket Bolt-on Kit
- B100BTSA - Stainless Bolt-on Kit
- B100WOA - Weld-on Kit

See pages 39-46 for more bracket kit information and complete bracket kit listings.

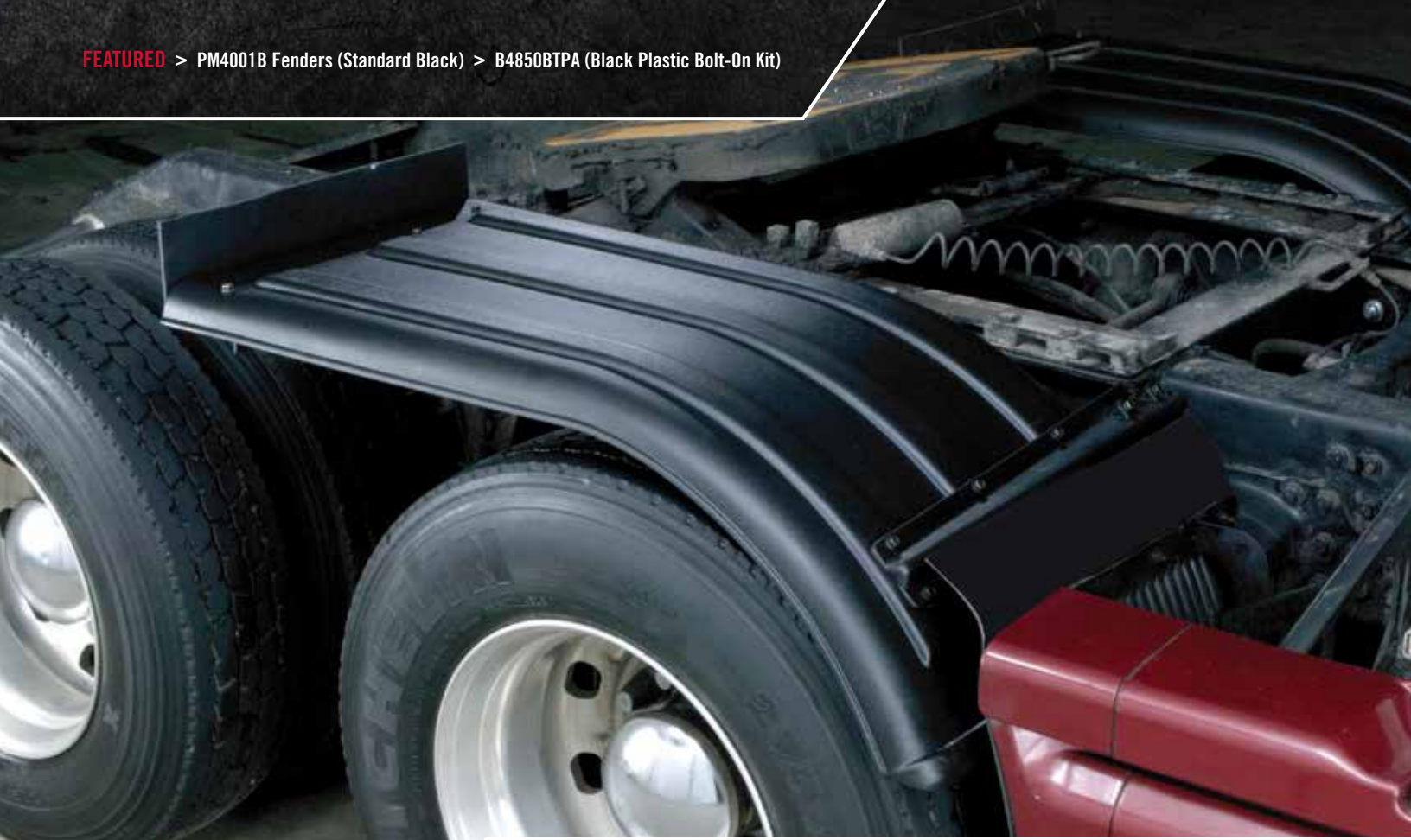

MIN4050 FENDER SERIES:

THE HALF HORSE

- MIN4050 is designed to fit a tandem axle tractor or trailer as a half fender.
- The set consists of 2 pieces (2 - PM4001 fender sections).
- The total weight of the MIN4050 fender kit is less than 23 lbs.
- Optional splash guards are available.
- See page 38 for complete list of fenders and additional color, material, and lightbox options.
- Visit www.minimizer.com for a fully detailed CADD drawing and individual part numbers by color.

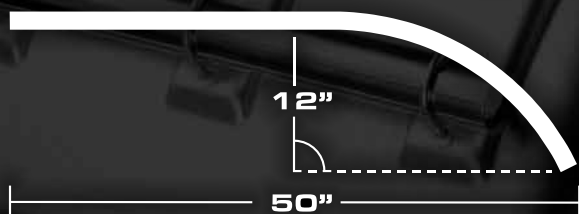

FENDER WIDTH: 25"

MATERIAL OPTIONS

STANDARD



UNIQUE



INSTALLATION KITS

- B4850BTPA - Black Plastic Bolt-on Kit
- B4850BTPACF - Carbon Fiber Plastic Bolt-on Kit
- #100129 - Mirror Finish Plastic Bolt-on Kit
- B4850BTPAPL - Liquid Platinum Plastic Bolt-on Kit
- B4850PBA - Plastic Paddle Bracket Bolt-on Kit
- B4850BTSa - Stainless Bolt-on Kit
- B4850W0A - Weld-on Kit

See pages 39-46 for more bracket kit information and complete bracket kit listings.



MIN950 FENDER SERIES:

THE BRUTE HALF

- MIN950 is designed to fit a tandem axle tractor / trailer as a half fender.
- The set consists of 2 pieces (2 - PM901 fender sections).
- The total weight of the MIN950 fender kit is less than 26 lbs.
- Optional splash guard available.
- See page 38 for complete list of fenders and additional color, material, and lightbox options.
- Visit www.minimizer.com for a fully detailed CADD drawing and individual part numbers by color.

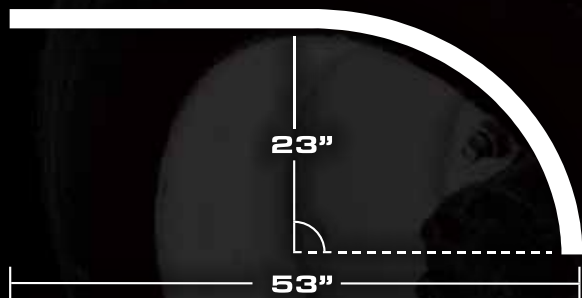

FENDER WIDTH: 25"

MATERIAL OPTIONS

STANDARD



UNIQUE



INSTALLATION KITS

- B4850BTPA - Black Plastic Bolt-on Kit
- B4850BTPACF - Carbon Fiber Plastic Bolt-on Kit
- #100129 - Mirror Finish Plastic Bolt-on Kit
- B4850BTPAPL - Liquid Platium Plastic Bolt-on Kit
- B4850PBA - Plastic Paddle Bracket Bolt-on Kit
- B4850BTSA - Stainless Bolt-on Kit
- B4850WOA - Weld-on Kit

See pages 39-46 for more bracket kit information and complete bracket kit listings.



MIN1550 FENDER SERIES:

SQUARE BACK HALF

- MIN1550 is designed to fit a tandem axle tractor / trailer as a half fender.
- The set consists of 2 pieces (2 – PM1501 fender sections).
- The total weight of the MIN1550 is less than 22 lbs.
- Optional splash guard available.
- See page 38 for complete list of fenders and additional color, material, and lightbox options.
- Visit www.minimizer.com for a fully detailed CADD drawing and individual part numbers by color.



FENDER WIDTH: 25"

MATERIAL OPTIONS

STANDARD



UNIQUE



INSTALLATION KITS

- B4850BTPA - Black Plastic Bolt-on Kit
- B4850BTPACF - Carbon Fiber Plastic Bolt-on Kit
- #100129 - Mirror Finish Plastic Bolt-on Kit
- B4850BTPAPL - Liquid Platinum Plastic Bolt-on Kit
- B4850PBA - Plastic Paddle Bracket Bolt-on Kit
- B4850BTSA - Stainless Bolt-on Kit
- B4850WOA - Weld-on Kit

See pages 39-46 for more bracket kit information and complete bracket kit listings.



*LIGHT BOX OPTION AVAILABLE

MIN900 FENDER SERIES:

THE BRUTE

- MIN900 is designed to fit a tandem axle tractor or trailer.
- The set consists of 4 pieces (4 - PM901 single fenders).
- The total weight of the MIN900 fender kit is less than 52 lbs.
- 10" extension available for trucks with 60" axle spacing.
- See page 38 for complete list of fenders and additional color, material, and lightbox options.
- Visit www.minimizer.com for a fully detailed CADD drawing and individual part numbers by color.



MATERIAL OPTIONS

STANDARD



UNIQUE



INSTALLATION KITS

- B4578BTPA - Black Plastic Bolt-on Kit
- B4578BTPACF - Carbon Fiber Plastic Bolt-on Kit
- #100128 - Mirror Finish Plastic Bolt-on Kit
- B4578BTPAPL - Liquid Platium Plastic Bolt-on Kit
- B4578PBA - Paddle Bracket Bolt-on Kit
- B4578BTSA - Stainless Bolt-on Kit
- B4578W0A - Weld-on Kit

See pages 39-46 for more bracket kit information and complete bracket kit listings.



MIN4000 FENDER SERIES:

THE WORK HORSE

- MIN4000 is designed to fit a tandem axle tractor or trailer.
- The set consists of 4 pieces (4-PM4001 fender sections).
- The total weight of the MIN4000 fender kit is less than 42 lbs.
- 10" extension available for trucks with 60" axle spacing.
- See page 38 for complete list of fenders and additional color, material, and lightbox options.
- Visit www.minimizer.com for a fully detailed CADD drawing and individual part numbers by color.



FENDER WIDTH: 25"

MATERIAL OPTIONS

STANDARD



UNIQUE



INSTALLATION KITS

- B4578BTPA - Black Plastic Bolt-on Kit
- B4578BTPACF - Carbon Fiber Plastic Bolt-on Kit
- #100128 - Mirror Finish Plastic Bolt-on Kit
- B4578BTPAPL - Liquid Platinum Plastic Bolt-on Kit
- B4578PBA - Paddle Bracket Bolt-on Kit
- B4578BTSA - Stainless Bolt-on Kit
- B4578WOA - Weld-on Kit

See pages 39-46 for more bracket kit information and complete bracket kit listings.



*LIGHT BOX OPTION AVAILABLE

MIN1500/1554 FENDER SERIES:

SQUARE BACK BRUISER

- MIN1500 is designed to fit a tandem axle tractor or trailer with a 52" axle spread.
- MIN1554 is designed to fit a tandem axle tractor or trailer with a 54" axle spread.
- The set consists of 4 pieces (4 - PM1501/PM1554 single fenders).
- The total weight of the MIN1500/1554 fender kit is less than 45 lbs.
- See page 38 for complete list of fenders and additional color, material, and lightbox options.
- Visit www.minimizer.com for a fully detailed CADD drawing and individual part numbers by color.



FENDER WIDTH: 25"

MATERIAL OPTIONS

STANDARD



UNIQUE



INSTALLATION KITS

- B4578BTPA - Black Plastic Bolt-on Kit
- B4578BTPACF - Carbon Fiber Plastic Bolt-on Kit
- #100128 - Mirror Finish Plastic Bolt-on Kit
- B4578BTPAPL - Liquid Platinum Plastic Bolt-on Kit
- B4578PBA - Paddle Bracket Bolt-on Kit
- B4578BTSA - Stainless Bolt-on Kit
- B4578W0A - Weld-on Kit

See pages 39-46 for more bracket kit information and complete bracket kit listings.



*LIGHT BOX OPTION AVAILABLE

MIN1352/1354 FENDER SERIES:

THE DOUBLE DEUCE

- MIN1352 is designed to fit a tandem axle tractor or trailer with a 52" axle spread.
- MIN1354 is designed to fit a tandem axle tractor or trailer with a 54" axle spread.
- The set consists of 4 pieces (4 - PM1352/PM1354 single fenders).
- The total weight of the MIN1352/1354 fender kit is less than 44 lbs.
- See page 38 for complete list of fenders and additional color, material, and lightbox options.
- Visit www.minimizer.com for a fully detailed CADD drawing and individual part numbers by color.



MATERIAL OPTIONS

STANDARD



UNIQUE



INSTALLATION KITS

- B9900BTPA - Black Plastic Bolt-on Kit
- B9900BTPACF - Carbon Fiber Plastic Bolt-on Kit
- #100131 - Mirror Finish Plastic Bolt-on Kit
- B9900BTPAPL - Liquid Platinum Plastic Bolt-on Kit
- B9900PBA - Plastic Paddle Bracket Bolt-on Kit
- B9900BTSA - Stainless Bolt-on Kit
- B9900WOA - Weld-on Kit

See pages 39-46 for more bracket kit information and complete bracket kit listings.



MIN200 FENDER SERIES:

THE ORIGINAL

- MIN200 is designed to fit a tandem axle tractor or trailer.
- The set consists of 4 pieces (4 - PM201 fender sections).
- The total weight of the MIN200 fender kit is less than 38 lbs.
- Optional trim plates (PM2014) are available.
- See page 38 for complete list of fenders and additional color, material, and lightbox options.
- Visit www.minimizer.com for a fully detailed CADD drawing and individual part numbers by color.



FENDER WIDTH: 25"

MATERIAL OPTIONS

STANDARD



UNIQUE



INSTALLATION KITS

- B200BTPA - Black Plastic Bolt-on Kit
- B200BTPACF - Carbon Fiber Plastic Bolt-on Kit
- #100127 - Mirror Finish Plastic Bolt-on Kit
- B200BTPAPL - Liquid Platinum Plastic Bolt-on Kit
- B200PBA - Plastic Paddle Bracket Bolt-on Kit
- B200WOA - Weld-on Kit

See pages 39-46 for more bracket kit information and complete bracket kit listings.



MIN300 FENDER SERIES:

THE TRIPLE THREAT

- MIN300 is designed to fit a tri-axle tractor or trailer.
- The set consists of 6 pieces (4 - PM201 front and rear sections and 2 - PM301 center sections).
- The total weight of the MIN300 fender kit is less than 55 lbs.
- Optional trim plates (PM2014) are available.
- See page 38 for complete list of fenders and additional color, material, and lightbox options.
- Visit www.minimizer.com for a fully detailed CADD drawing and individual part numbers by color.



FENDER WIDTH: 25"

MATERIAL OPTIONS

STANDARD



UNIQUE



INSTALLATION KITS

- B300BTPA - Black Plastic Bolt-on Kit
- B300BTPACF - Carbon Fiber Plastic Bolt-on Kit
- #100168 - Mirror Finish Plastic Bolt-on Kit
- B300BTPAPL - Liquid Platinum Plastic Bolt-on Kit
- B300PBA - Plastic Paddle Bracket Bolt-on Kit
- B300WOA - Weld-on Kit

See pages 39-46 for more bracket kit information and complete bracket kit listings.

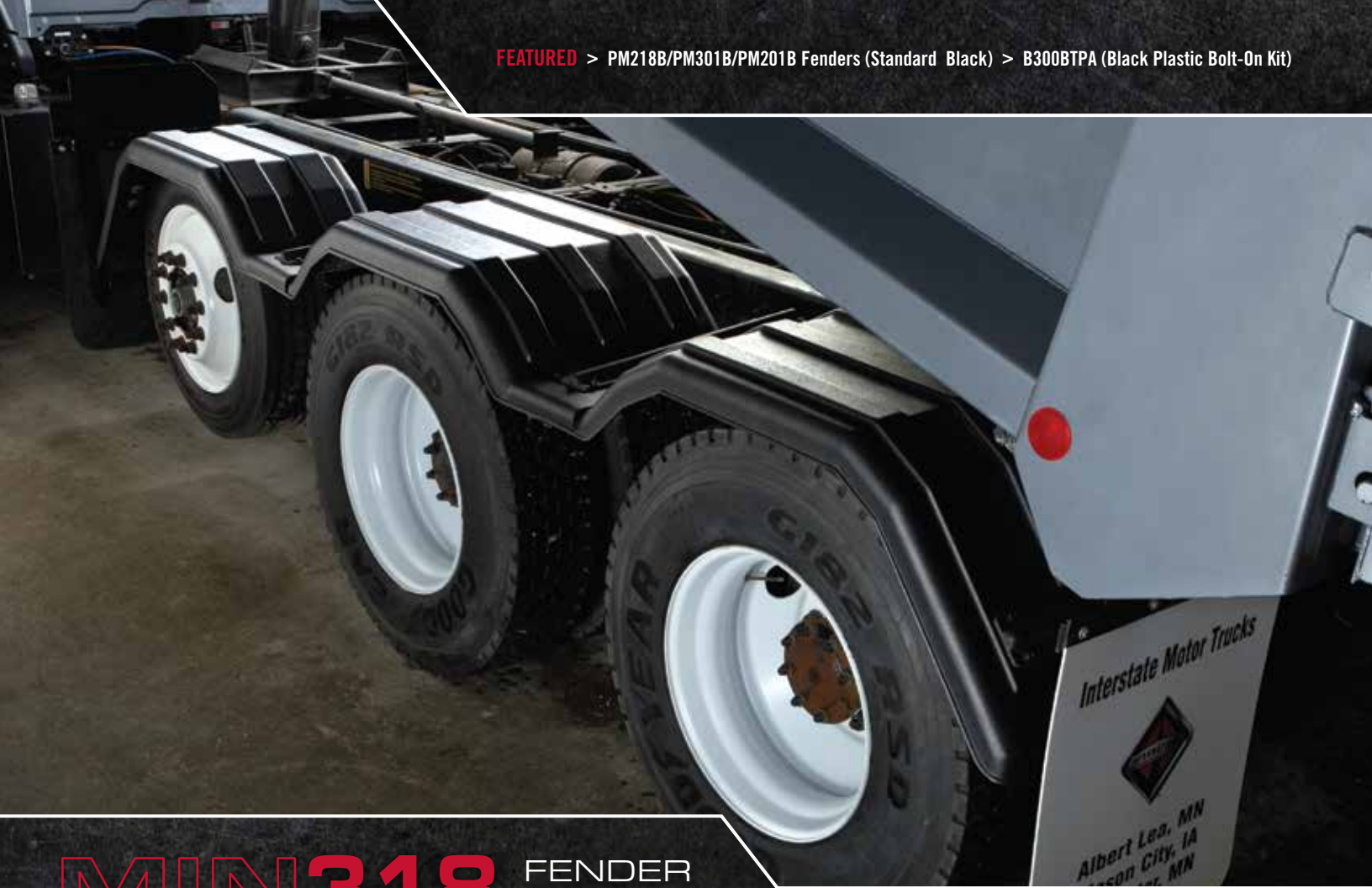

MIN318 FENDER SERIES:

ROLLING TRIPLES

- MIN318 is designed to fit a tri-axle tractor or trailer with a single wheel pusher axle.
- The set consists of 6 pieces (2 - PM218 front sections, 2 - PM301 center sections and 2 - PM201 rear sections).
- The total weight of the MIN318 fender kit is less than 51 lbs.
- Optional trim plates (PM2014) are available.
- See page 38 for complete list of fenders and additional color, material, and lightbox options.
- Visit www.minimizer.com for a fully detailed CADD drawing and individual part numbers by color.



FENDER WIDTH: **18"** (PM218)
25" (PM301/201)

MATERIAL OPTIONS

STANDARD



UNIQUE



INSTALLATION KITS

- B300BTPA - Black Plastic Bolt-on Kit
- B300BTPACF - Carbon Fiber Plastic Bolt-on Kit
- #100168 - Mirror Finish Plastic Bolt-on Kit
- B300BTPAPL - Liquid Platinum Plastic Bolt-on Kit
- B300PBA - Plastic Paddle Bracket Bolt-on Kit
- B300WOA - Weld-on Kit

See pages 39-46 for more bracket kit information and complete bracket kit listings.



PM202-302-1021 FENDER SERIES:

THE TRASHER

- PM202/302/1021 are designed to fit a tandem axle tractor or trailer with a single wheel pusher axle.
- The fender set is sold per individual piece. The front single wheel section is the PM1021, the center section is the PM302 and the rear section is the PM202.
- The total weight of the PM202/302/1021 fender set is less than 44 lbs.
- See page 38 for complete list of fenders and additional color, material, and lightbox options.
- Visit www.minimizer.com for a fully detailed CADD drawing and individual part numbers by color.

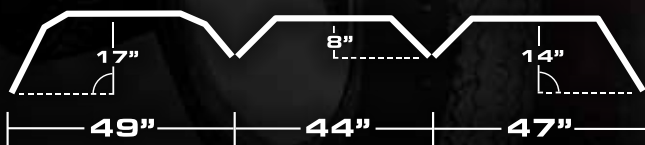

FENDER WIDTH: **18"** [PM1021]
24" [PM302/202]

MATERIAL OPTIONS

STANDARD



UNIQUE



INSTALLATION KITS

- B100BTPA - Black Plastic Bolt-on Kit
- B100BTPACF - Carbon Fiber Plastic Bolt-on Kit
- #100126 - Mirror Finish Plastic Bolt-on Kit
- B100BTPAPL - Liquid Platinum Plastic Bolt-on Kit
- B100PBA - Plastic Paddle Bracket Bolt-on Kit
- B100BTSA - Stainless Bolt-on Kit
- B100W0A - Weld-on Kit

*** 3 TOTAL INSTALLATION KITS REQUIRED**

See pages 39-46 for more bracket kit information and complete bracket kit listings.



*LIGHT BOX OPTION AVAILABLE

MINTA1554 FENDER SERIES:

THE LONG SHOT

- MINTA1554 is designed to fit a tri-axle tractor or trailer.
- The set consists of 6 pieces (4 - PM1554 front and rear sections, 2 - PMTA53 center sections).
- The total weight of the MINTA1554 fender kit is less than 80 lbs.
- See page 38 for complete list of fenders and additional color, material, and lightbox options.
- Visit www.minimizer.com for a fully detailed CADD drawing and individual part numbers by color.



FENDER WIDTH: 25"

MATERIAL OPTIONS

STANDARD



UNIQUE



INSTALLATION KITS

- B600BTPA - Black Plastic Bolt-on Kit
- B600BTPACF - Carbon Fiber Plastic Bolt-on Kit
- #100130 - Mirror Finish Plastic Bolt-on Kit
- B600BTPAPL - Liquid Platinum Plastic Bolt-on Kit
- B600PBA - Plastic Paddle Bracket Bolt-on Kit
- B600BTSA - Stainless Bolt-on Kit
- B600WOA - Weld-on Kit

See pages 39-46 for more bracket kit information and complete bracket kit listings.



*LIGHT BOX OPTION AVAILABLE

MINTA910 FENDER SERIES:

LONG & STREAMLINED

- MINTA910 is designed to fit a tri-axle tractor or trailer.
- The set consists of 6 pieces (4 - PM901 front and rear sections and 2 PMTA53 center sections).
- The total weight of the MINTA910 fender kit is less than 80 lbs.
- See page 38 for complete list of fenders and additional color, material, and lightbox options.
- Visit www.minimizer.com for a fully detailed CADD drawing and individual part numbers by color.



FENDER WIDTH: 25"

MATERIAL OPTIONS

STANDARD



UNIQUE



INSTALLATION KITS

- B600BTPA - Black Plastic Bolt-on Kit
- B600BTPACF - Carbon Fiber Plastic Bolt-on Kit
- #100130 - Mirror Finish Plastic Bolt-on Kit
- B600BTPAPL - Liquid Platinum Plastic Bolt-on Kit
- B600PBA - Plastic Paddle Bracket Bolt-on Kit
- B600BTS - Stainless Bolt-on Kit
- B600WOA - Weld-on Kit

See pages 39-46 for more bracket kit information and complete bracket kit listings.



MINTF900/1554 FENDER SERIES:

TANKER FENDERS

- MINTF900/1554 is designed to fit the front of a tanker trailer.
- The set consists of 8 pieces (2 - PMTF44EC End Caps, 4 - PMTF44 Center Sections, and 2 - PM901 Rear Sections or 2 - PM1554 Rear Sections).
- The total weight of the MINTF900/1554 fender kit is less than 49 lbs.
- See page 38 for complete list of fenders and additional color, material, and lightbox options.
- Visit www.minimizer.com for a fully detailed CADD drawing and individual part numbers by color.



FENDER WIDTH: 25.5"

MATERIAL OPTIONS

STANDARD



UNIQUE



INSTALLATION KITS

- B600BTPA - Black Plastic Bolt-on Kit
- B600BTPACF - Carbon Fiber Plastic Bolt-on Kit
- #100130 - Mirror Finish Plastic Bolt-on Kit
- B600BTPAPL - Liquid Platinum Plastic Bolt-on Kit
- B600PBA - Plastic Paddle Bracket Bolt-on Kit
- B600B TSA - Stainless Steel Bolt-on Kit
- B600WOA - Weld-on Kit

See pages 39-46 for more bracket kit information and complete bracket kit listings.



MIN2220 FENDER SERIES:

THE SS TWIN

- MIN2220 is designed to fit wide-base tires on a single, tandem, or multi axle tractor or trailer with 22.5" or 24.5" wheels.
- The set consists of 2 pieces (2-PM2221 single fender sections).
- The total weight of the MIN2220 fender kit is less than 24 pounds.
- See page 38 for complete list of fenders and additional color, material, and lightbox options.
- Visit www.minimizer.com for a fully detailed CADD drawing and individual part numbers by color.



FENDER WIDTH: 19.5"

MATERIAL OPTIONS

STANDARD



UNIQUE



INSTALLATION KITS

- #103144 - Stainless Steel Bolt-on Kit

See pages 39-46 for more bracket kit information and complete bracket kit listings.



MIN4020 FENDER SERIES:

THE **SS WORKHORSE**

- MIN4020 is designed to fit wide-base tires on tandem axle tractors or trailers with 52" - 54" spacing.
- The set consists of 4 pieces (4-PM4021 fender sections).
- The total weight of the MIN4020 fender kit is less than 32 pounds.
- See page 38 for complete list of fenders and additional color, material, and lightbox options.
- Visit www.minimizer.com for a fully detailed CADD drawing and individual part numbers by color.



FENDER WIDTH: **19.5"**

MATERIAL **OPTIONS**

STANDARD



UNIQUE



INSTALLATION **KITS**

- #103100 - Stainless Steel Bolt-on Kit

See pages 39-46 for more bracket kit information and complete bracket kit listings.



MIN4070 FENDER SERIES:

THE SS HALF HORSE

- MIN4070 is designed to fit wide-base tires on tandem axle tractors or trailers as a half fender.
- The set consists of 2 pieces (2-PM4021 fender sections).
- The total weight of the MIN4070 fender kit is less than 16 pounds.
- See page 38 for complete list of fenders and additional color, material, and lightbox options.
- Visit www.minimizer.com for a fully detailed CADD drawing and individual part numbers by color.



FENDER WIDTH: 19.5"

MATERIAL OPTIONS

STANDARD



UNIQUE



INSTALLATION KITS

- #103143 - Stainless Steel Bolt-on Kit

See pages 39-46 for more bracket kit information and complete bracket kit listings.



MIN9020 FENDER SERIES:

THE **SS BRUTE**

- MIN9020 is designed to fit wide-base tires on tandem axle tractors or trailers with 52" - 54" spacing.
- The set consists of 4 pieces (4-PM9021 fender sections).
- The total weight of the MIN9020 fender kit is less than 42 pounds.
- See page 38 for complete list of fenders and additional color, material, and lightbox options.
- Visit www.minimizer.com for a fully detailed CADD drawing and individual part numbers by color.

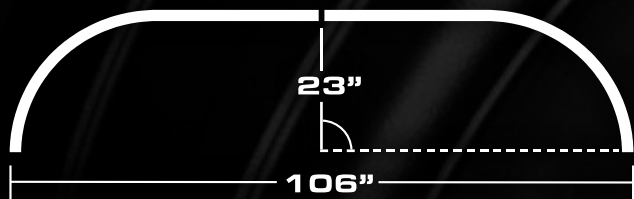

FENDER WIDTH: **19.5"**

MATERIAL **OPTIONS**

STANDARD



UNIQUE



INSTALLATION **KITS**

- #103100 - Stainless Steel Bolt-on Kit

See pages 39-46 for more bracket kit information and complete bracket kit listings.



MIN9070 FENDER SERIES:

THE **SS HALF BRUTE**

- MIN9070 is designed to fit wide-base tires on tandem axle tractors or trailers as a half fender.
- The set consists of 2 pieces (2-PM9021 fender sections).
- The total weight of the MIN9070 fender kit is less than 16 pounds.
- See page 38 for complete list of fenders and additional color, material, and lightbox options.
- Visit www.minimizer.com for a fully detailed CADD drawing and individual part numbers by color.

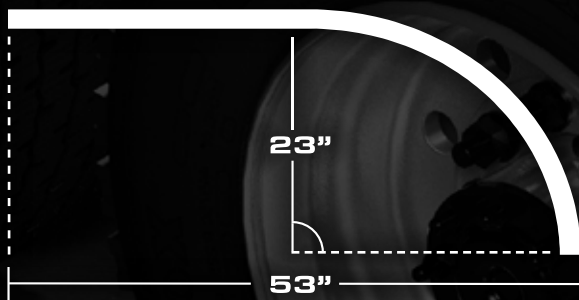

FENDER WIDTH: 19.5"

MATERIAL **OPTIONS**

STANDARD



UNIQUE



INSTALLATION **KITS**

- #103143 - Stainless Steel Bolt-on Kit

See pages 39-46 for more bracket kit information and complete bracket kit listings.



MINTR4020 FENDER SERIES:

THE **SS TRAILER HORSE**

- MINTR4020 is designed to fit wide-base tires on trailers with 48" spacing commonly found on rear of tank trailers.
- The set consists of 4 pieces (4-PMTR4021 fender sections).
- The total weight of the MINTR4020 fender kit is less than 30 pounds.
- See page 38 for complete list of fenders and additional color, material, and lightbox options.
- Visit www.minimizer.com for a fully detailed CADD drawing and individual part numbers by color.



FENDER WIDTH: **19.5"**

MATERIAL **OPTIONS**

STANDARD



UNIQUE



INSTALLATION **KITS**

- #103100 - Stainless Steel Bolt-on Kit

See pages 39-46 for more bracket kit information and complete bracket kit listings.



MIN161200 FENDER SERIES:

THE LONER

- MIN161200 is designed to fit a single tractor or trailer 16.5" tire up to a low-profile 22.5" tire (255 70R 22.5).
- The set consists of 2 pieces (2 - PM1612 fender sections).
- Works great for steerable or lift axles.
- The total weight of the MIN161200 fender kit is less than 12 pounds.
- See page 38 for complete list of fenders and additional color, material, and lightbox options.



FENDER WIDTH: 12"

MATERIAL OPTIONS

STANDARD



UNIQUE



INSTALLATION KITS

- BSHORTLIFTAX - Lift Axle Bracket Kit (Page 45)
- Steerable Lift Axle Kit (Page 46)

See pages 39-46 for more bracket kit information and complete bracket kit listings.



MIN221800 FENDER SERIES:

18 & SINGLE

- MIN221800 is designed to fit a super single tractor or trailer 22.5" or 24.5" wheel (445).
- The set consists of 2 pieces. (2 - PM2218 fender sections).
- The total weight of the MIN221800 is less than 16 pounds.
- MIN221800 works great on super singles, lift axles and steer axles.
- See page 38 for complete list of fenders and additional color, material, and lightbox options.



FENDER WIDTH: 18"

MATERIAL OPTIONS

STANDARD



UNIQUE



INSTALLATION KITS

- #103144 - Stainless Bolt-on Kit (Pictured on page 44)
- B100BTPA - Black Plastic Bolt-on Kit
- B100BTPACF - Carbon Fiber Plastic Bolt-on Kit
- #100126 - Mirror Finish Plastic Bolt-on Kit
- B100BTPAPL - Liquid Platinum Plastic Bolt-on Kit
- B100PBA - Plastic Paddle Bracket Bolt-on Kit
- B100WOA - Weld-on Kit

See pages 39-46 for more bracket kit information and complete bracket kit listings.



MIN1400 FENDER SERIES:

THE QUARTER

- MIN1400 is designed to fit standard dual tractor or trailer wheels.
- The total weight of the MIN1400 fender kit is less than 35 lbs.
- This a complete kit including fenders and all mounting hardware.
- Kit Options
 - MIN1400B does not include either a post nor flange mount and is intended to replace an existing quarter fender.
 - MIN1400BF includes two flange mounts.
 - MIN1400BP includes two post mounts.

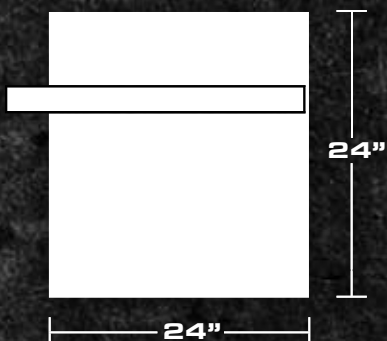

MATERIAL OPTIONS

STANDARD



UNIQUE



INSTALLATION KITS



• PBFLANGEQF - Flange Mount



• PBPOSTQF - Post Mount



ARMADILLO FENDER SERIES:

THE ARMADILLO

- Ideal for keeping mud off windows and mirrors. Improve your organization's safety record by keeping operator's area protected.
- Forever Shape™ pops back after impact. It will not stress crack. Fits on applications where metal fenders are simply not practical.
- Superior control of over spray and rocks helps keep equipment cleaner and prevents damage.
- Please reference Part# PM1100B, this fender is sold individually and not as a set.



FENDER WIDTH: 16"

MATERIAL OPTIONS

STANDARD



UNIQUE



INSTALLATION KITS

BRACKET KITS NOT AVAILABLE FOR PM1100B.



G1000 FENDER SERIES:

THE G1000

- Ideal for keeping mud off windows and mirrors. Improve your organization's safety record by keeping operator's area protected.
- Forever Shape™ pops back after impact. It will not stress crack. Fits on applications where metal fenders are simply not practical.
- Superior control of over spray and rocks helps keep equipment cleaner and prevents damage.
- Reference Part# PCG1000B, this fender is sold individually and not as a set.



FENDER WIDTH: 20.5"

MATERIAL OPTIONS

STANDARD



UNIQUE



INSTALLATION KITS

BRACKET KITS NOT AVAILABLE FOR #PCG1000B.



AUXILIARY LIFT FENDER SERIES:

THE AUXILIARY LIFT

- Improve your organization's safety record by keeping operator's area protected.
- Forever Shape™ pops back after impact. It will not stress crack. Fits on applications where metal fenders are simply not practical.
- Superior control of water spray and rocks keep equipment and loads cleaner.
- Reference Part# PMC10R - Curbside and/or PMC10L - Road Side

FRONT



12"

SIDE



9"

31"

MATERIAL OPTIONS

STANDARD



UNIQUE



INSTALLATION KITS

BRACKET KITS NOT AVAILABLE FOR PMC10R OR PMC10L.

FENDER OPTIONS:

MATERIAL & FINISH



Fender Series	Options	Standard Black	Standard Galvanized	Standard Red	Standard White	Standard Green	TPO Paintable	Diamond Plate Black	Diamond Plate Silver	Liquid Platinum	Carbon Fiber	Silver Mirror Finish	Smoky Black Mirror Finish	Optional Light Box
MIN1600		X	X	X	X	X	X	X	X	X	X	N/A	N/A	N/A
MIN1900		X	X	X	X	X	X	X	X	X	X	N/A	N/A	X
MIN2260		X	X	X	X	X	X	X	X	X	X	X	X	X*
MIN2480		X	X	X	X	N/A	N/A	X	X	N/A	N/A	N/A	N/A	X
MIN150		X	X	X	X	X	X	X	X	X	X	N/A	N/A	N/A
MIN4050		X	X	X	X	X	X	X	X	X	X	X	X	N/A
MIN950		X	X	X	X	N/A	X	X	X	X	X	X	X	N/A
MIN1550		X	X	X	X	N/A	X	X	X	X	X	N/A	N/A	N/A
MIN4000		X	X	X	X	X	X	X	X	X	X	X	X	N/A
MIN900		X	X	X	X	N/A	X	X	X	X	X	X	X	X*
MIN1500		X	X	X	X	N/A	X	X	X	X	X	N/A	N/A	X
MIN1554		X	X	X	X	N/A	X	X	X	X	X	N/A	N/A	X
MIN135200		X	X	X	X	N/A	X	X	X	X	X	X	X	X*
MIN135400		X	X	X	X	N/A	X	X	X	X	X	X	X	X*
MIN200		X	X	X	X	X	X	X	X	X	X	N/A	N/A	N/A
MIN300		X	X	X	X	X	X	X	X	X	X	N/A	N/A	N/A
MIN318		X	X	X	X	X	X	X	X	X	X	N/A	N/A	N/A
MIN202-302-1021		X	X	X	X	X	N/A	X	X	N/A	N/A	N/A	N/A	N/A
MINTA1554		X	X	X	X	N/A	X	X	X	X	X	N/A	N/A	X
MINTA910		X	X	X	X	N/A	X	X	X	X	X	N/A	N/A	X
MINTF900		X	X	X	X	N/A	X	X	X	X	X	N/A	N/A	N/A
MINTF1554		X	X	X	X	N/A	X	X	X	X	X	N/A	N/A	N/A
MIN161200		X	X	X	X	X	X	X	X	X	X	N/A	N/A	N/A
MIN2220		X	X	X	X	X	X	X	X	X	X	X	X	N/A
MIN4020		X	X	X	X	X	X	X	X	X	X	X	X	N/A
MIN4070		X	X	X	X	X	X	X	X	X	X	X	X	N/A
MINTR4020		X	X	X	X	X	X	X	X	X	X	X	X	N/A
MIN9020		X	X	X	X	N/A	X	X	X	X	X	X	X	N/A
MIN9070		X	X	X	X	N/A	X	X	X	X	X	X	X	N/A
MIN221800		X	X	X	X	X	X	X	X	X	X	N/A	N/A	N/A
MIN1400		X	N/A	N/A	N/A	N/A	N/A	N/A	N/A	N/A	N/A	N/A	N/A	N/A

*Light box option not available in Silver or Smoky Black Mirror Finish

ORIGINAL PLASTIC BOLT-ON KIT

THE BEST FENDER BRACKET SYSTEMS IN THE INDUSTRY
HERE'S WHY: **ULTIMATE DURABILITY**

- DESIGNED FOR FLEXIBILITY TO SOFTEN ROAD VIBRATION
- 100% COMPOSITE MATERIAL WILL NEVER STRESS CRACK
- NEVER NEEDS PAINT & WILL NEVER RUST OR CORRODE



The competition gives you metal brackets with composite fenders...
WHY? We do it right, you get a nearly indestructible bracket with your Minimizer Fender!

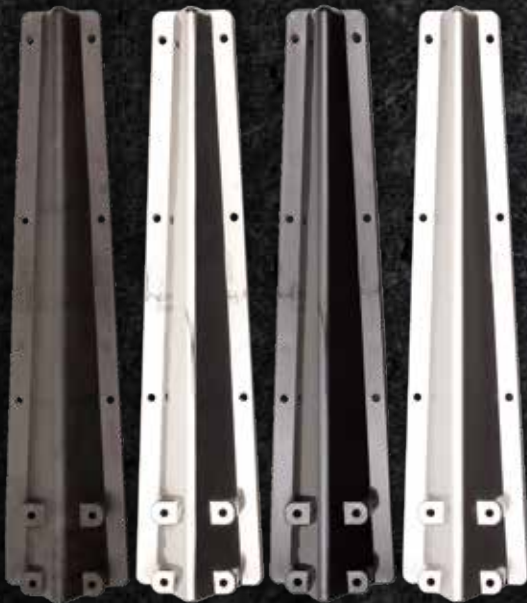

You need to have the right tools for the trade, right? You know that already, you bought Minimizer Fenders! What would nearly indestructible fenders be without the industry's toughest and most reliable brackets to match?

You need brackets that won't bend out of shape with the slightest tap or break and do nothing but cost you hard earned money. At Minimizer our Fenders & Bracket Systems are Guaranteed for Life! That's good math for you! How can Minimizer make such an offer? It's simple, we have total confidence in the design and performance of our fenders and bracket kits.

Minimizer Brackets are designed for strength and they have remarkable staying power - when bumped or bent they "give" slightly and spring back into shape without dents or paint chips. These brackets will last as long as you own your Minimizer Fenders - we guarantee it!

Available in Standard Black, Mirror Finish, Carbon Fiber, and Liquid Platinum!

PADDLE BRACKET BOLT-ON KIT

THE BEST FENDER BRACKET SYSTEMS IN THE INDUSTRY
SLEEK NEW LOOK: **SAME DURABILITY**

- EASIER INSTALLATION AND REDUCES SUSPENSION BULK
- 100% COMPOSITE MATERIAL WILL NEVER STRESS CRACK
- NEVER NEEDS PAINT & WILL NEVER RUST OR CORRODE



The competition gives you metal brackets with composite fenders...
WHY? We do it right, you get a nearly indestructible bracket with your Minimizer Fender!



We thought long and hard about how to improve our bracket systems. We set out to duplicate the durability and ability to absorb impact of the original Standard Plastic Bolt-on Bracket System with a low profile custom look.

The Minimizer Paddle Bracket System is designed to be mounted directly to the frame which eliminates the need to use spacers in most cases. The sleek & compact profile allows the bracket arm to fit lower on the frame rail if needed, creating more clearance between the frame and the fifth wheel plate. All of the fastening hardware is hidden beneath the fender creating a more streamlined and aesthetically pleasing look.

But don't let it's good looks fool you, all of Minimizer Bracket Systems have been Tested and Tortured to ensure that it will meet the performance expectations of demanding jobsites and unforgiving roads.

FENDER BRACKET SYSTEMS:

INSTALLATION KITS

B100 SERIES:



B100BTPA - Plastic Bolt-on Kit



B100BTPACF - Carbon Fiber Plastic Bolt-on Kit



#100126 - Mirror Finish Plastic Bolt-on Kit



B100BTPAPL - Liquid Platinum Plastic Bolt-on Kit



B100PBA - Paddle Bracket Kit



B100BTSA - Stainless Bolt-on Kit



B100WOA - Weld-on Kit

B200 SERIES:



B200BTPA - Plastic Bolt-on Kit



B200BTPACF - Carbon Fiber Plastic Bolt-on Kit



#100127 - Mirror Finish Plastic Bolt-on Kit



B200BTPAL - Liquid Platinum Plastic Bolt-on Kit



B200PBA - Paddle Bracket Kit



B200WOA - Weld-on Kit

B300 SERIES:



B300BTPA - Plastic Bolt-on Kit



B300BTPACF - Carbon Fiber Plastic Bolt-on Kit



#100168 - Mirror Finish Plastic Bolt-on Kit



B300BTPAPL - Liquid Platinum Plastic Bolt-on Kit



B300PBA - Paddle Bracket Kit



B300WOA - Weld-on Kit

B4578 SERIES:



B4578BTPA - Plastic Bolt-on Kit



B4578BTPACF - Carbon Fiber Plastic Bolt-on Kit



#100128 - Mirror Finish Plastic Bolt-on Kit



B4578BTPAPL - Liquid Platinum Plastic Bolt-on Kit



B4578PBA - Paddle Bracket Kit



B4578BTSA - Stainless Bolt-on Kit



B4578WOA - Weld-on Kit

FENDER BRACKET SYSTEMS:

INSTALLATION KITS

B4850 SERIES:



B4850BTPA - Plastic Bolt-on Kit



B4850BTPACF - Carbon Fiber Plastic Bolt-on Kit



#100129 - Mirror Finish Plastic Bolt-on Kit



B4850BTPAPL - Liquid Platinum Plastic Bolt-on Kit



B4850PBA - Paddle Bracket Kit



B4850B TSA - Stainless Bolt-on Kit



B4850W OA - Weld-on Kit

B600 SERIES:

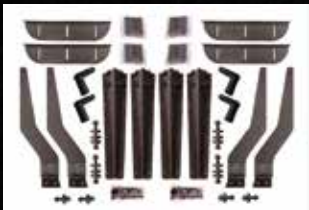

B600BTPA - Plastic Bolt-on Kit

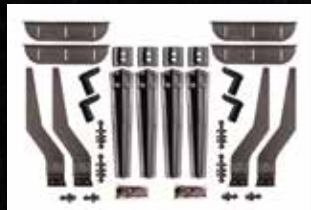

B600BTPACF - Carbon Fiber Plastic Bolt-on Kit

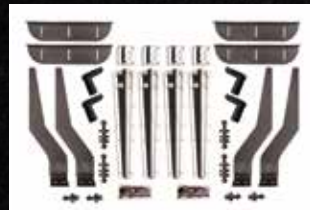

#100130 - Mirror Finish Plastic Bolt-on Kit

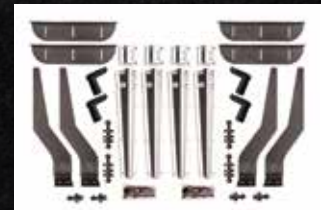

B600BTPAPL - Liquid Platinum Plastic Bolt-on Kit



B600PBA - Paddle Bracket Kit

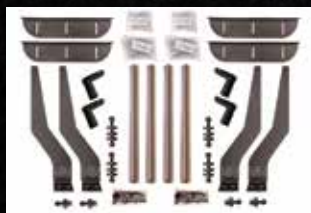

B600B TSA - Stainless Bolt-on Kit



B600W OA - Weld-on Kit

B9900 SERIES:



B9900BTPA - Plastic Bolt-on Kit



B9900BTPACF - Carbon Fiber Plastic Bolt-on Kit



#100131 - Mirror Finish Plastic Bolt-on Kit



B9900BTPAPL - Liquid Platinum Plastic Bolt-on Kit



B9900PBA - Paddle Bracket Kit



B9900BTSA - Stainless Bolt-on Kit



B9900WOA - Weld-on Kit

SUPERSINGLE SERIES:



Part # 103100 - Stainless Steel Bolt-on Kit



Part # 103143 - Stainless Steel Bolt-on Kit



Part # 103144 - Stainless Steel Bolt-on Kit

All Minimizer Fender Bracket System Installation Kits come with the applicable mounting hardware for proper installation:

- Bracket Arm Assembly
- Plastic Center Bracket Assembly (Plastic Arm mounted to Steel Angle)
- Plastic Angle/Height Support
- Mounting Flanges, Mounting Bolts, and Spacers
- All Bolts, Washers, and Nuts

LIFT AXLES BRACKETS



- Designed specifically for 5" round lift axles.
- Easy bolt-on design for a quick installation.
- Available for single wheel applications.
- Lift Axle Fenders are also available.
- Fenders are molded for a specific tire size.
- Please reference Part# BSHORTLIFTAX
- Bracket Kit clamps on to a 5" round axle allowing the fender to raise and lower with the axle.

VISIT WWW.MINIMIZER.COM FOR MORE INFORMATION ON LIFT AXLE BRACKET OPTIONS

STEERABLE BRACKETS



- Designed specifically for steerable axles.
- Easy bolt-on design for a quick installation.
- Over 20 different kits are available depending on the style and brand of your axle.
- Steerable Axle Fenders are also available.
- Call 1-800-248-3855 for part numbers and availability.
- Steerable kits are made to bolt on using existing holes on the brake assembly allowing the fender to raise, lower and steer with the wheel.

VISIT WWW.MINIMIZER.COM FOR MORE INFORMATION ON STEERABLE AXLE BRACKET OPTIONS