



Section 6

Soupapes de suspension à air
Suspension Air Valves

Section 6 • Soupapes de suspension à air
 • Suspension Air Valves

**Soupapes de contrôle de niveau
 Height Control Valves**

New	Notes
FS-6586NT	* Metal construction. * Immediate Response. * Left or Right side installation.
Replaces: Neway 90554241	

New	Notes
FS-6843	* Engineered Plastic construction. * Immediate Response. * Left or Right side installation.
Replaces: Haldex 90555105	

New	Notes
FS-6586NTA	* Immediate Response. * Left or Right side installation. * FS-6678 Linkage Kit included.

New	Notes
FS-6587	* Immediate Response. * Left or Right side installation. * FS-6590 Dump Valve included. * Normally Open - needs air to dump.
Replaces: Neway 90554271	

New	Notes
FS-6590	* Dump Valve <only> for FS-6587. * Normally Open - needs air to dump.

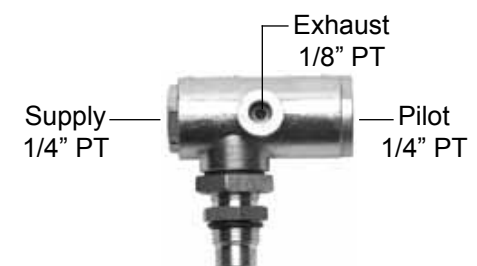
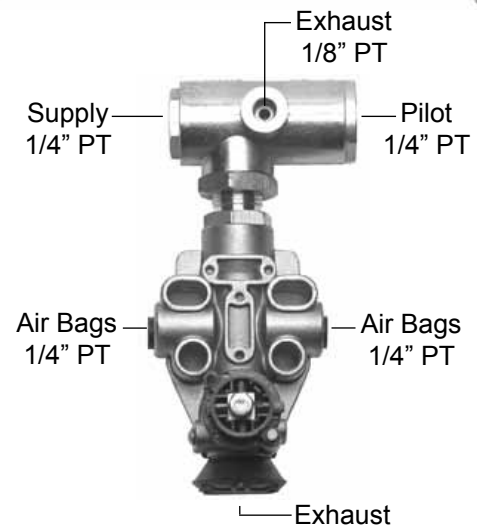
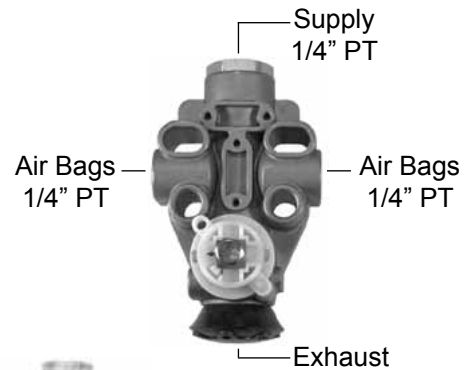

Section 6 . Soupapes de suspension à air Suspension Air Valves

Soupapes de contrôle de niveau Height Control Valves

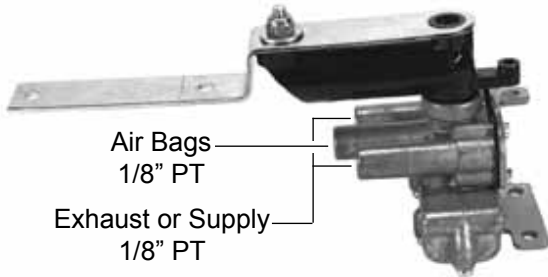

New	Notes
FS-6586	* Left or Right side installation. * Less responsive to short duration axle position changes.
Replaces: Neway 90054007	

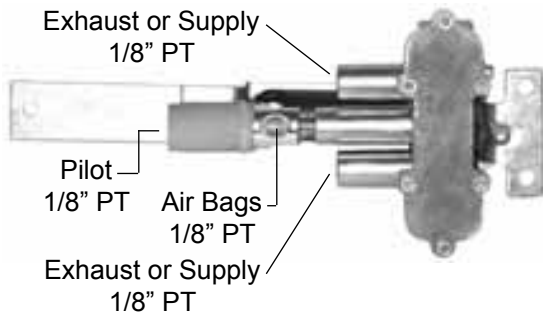

New	Notes
FS-6589NO	* Delayed Response. * Left or Right side installation. * Unresponsive to short duration axle position changes. * FS-6588NO Dump Valve included * Normally Open - needs air to dump.
Replaces: Neway 90554334	



New	Notes
FS-6588NO	* Dump Valve <only> for FS-6589NO * Normally Open - needs air to dump.
Replaces: Neway 90554335	

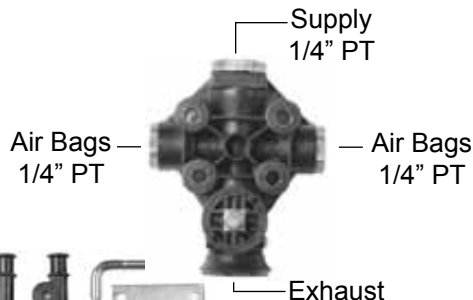

New	Notes
FSKN27000N	* Immediate Response. * Left or Right side installation. * Made of Engineered Plastic * Linkage Kit included. * Mounting Adapter Plate included
Replaces: Haldex KN27000	

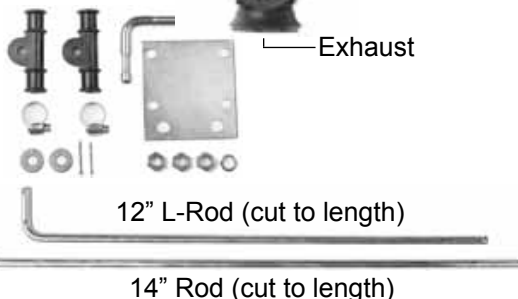

Propriété exclusive de FleetSpec. Toute reproduction interdite. / Exclusive property of FleetSpec. Reproduction prohibited.

Section 6 • Soupapes de suspension à air • Suspension Air Valves

Soupapes de contrôle de niveau PR Plus Height Control Valves

New	Notes
FS-6577	* Fast Response, tight Dead Zone. * Straight Manifold. * 3/8" P-T-C Supply & Delivery Ports. * 1/4" P-T-C swivel Dump Port. * Integrated Dump Valve (N.O.)
Replaces: Haldex 90555376 Kenworth 90555143	

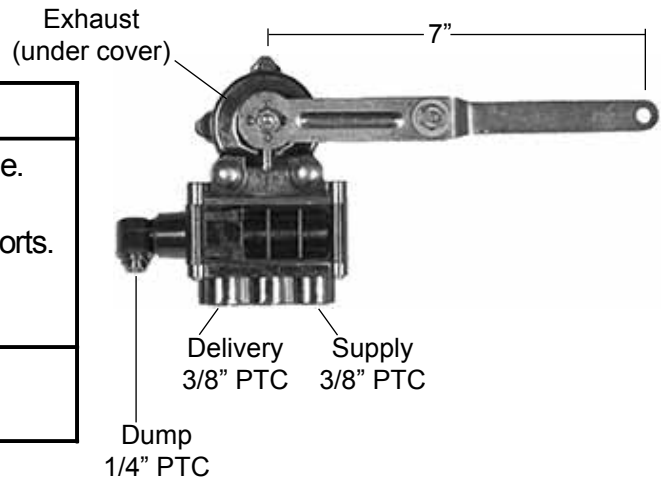

New	Notes
FS-6578	* Fast Response, tight Dead Zone. * Straight Manifold. * 1/4" PT Supply & Delivery Ports. * 1/4" P-T-C swivel Dump Port. * Integrated Dump Valve (N.O.)
Replaces: Haldex 90554950 Euclid E-13918	

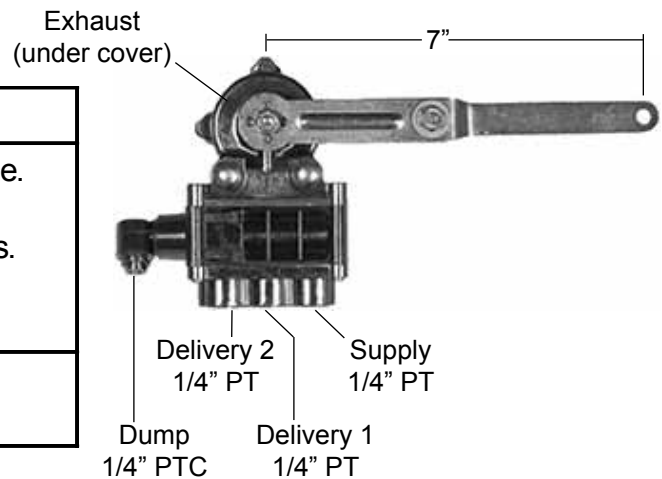

New	Notes
FS-6579	* Fast Response, tight Dead Zone * 3/8" P-T-C Supply & Delivery Ports. * 1/4" P-T-C Swivel Dump Port. * Integrated Dump Valve (N.O.)
Replaces: Haldex 90555375, 90555141 Kenworth G90-1073-024, -026, -095 G90-1099-024, -026, -095	

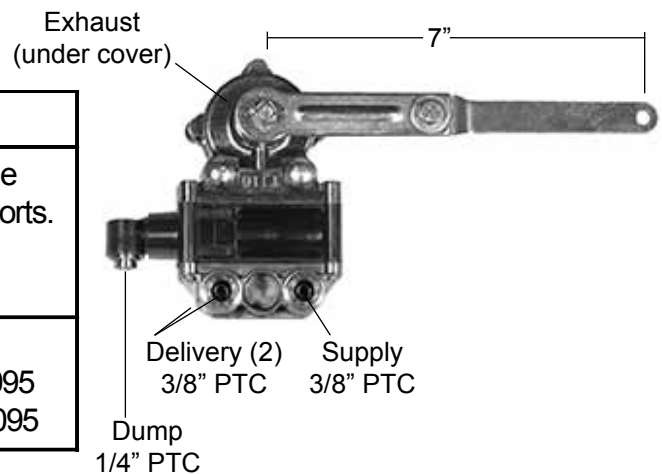

Propriété exclusive de FleetSpec. Toute reproduction interdite. / Exclusive property of FleetSpec. Reproduction prohibited.

Section 6 • Soupapes de suspension à air • Suspension Air Valves

Soupapes de contrôle de niveau Height Control Valves

New	Notes
FS-H00450CE	* 2 Install Brackets and 2 Arms cover a variety of installations.
Replaces: Euclid E-9623, Hadley H00450CE, Tectran 80-1006. Volvo 3130560	

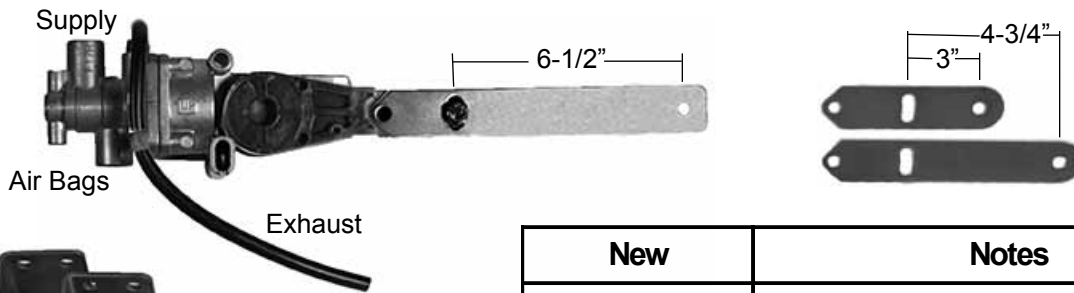
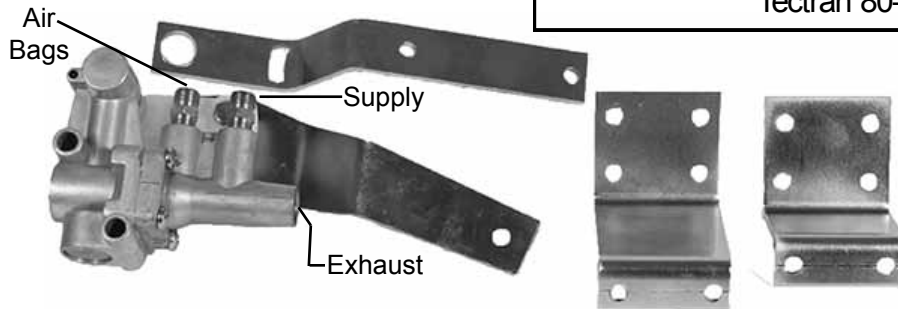

New	Notes
FS-H00500C	Hadley style Cab Height Control 2 Install Brackets and 3 Arms cover a variety of installations.
Replaces: Euclid E-9624, Hadley H00500C	

New	Notes
FS-H00600P	* 2 arms and a 12-1/4" Linkage covers a variety of installations. * Lever travel 45° up to 20° down.
Replaces: Euclid E-11464, Hadley H00600P	

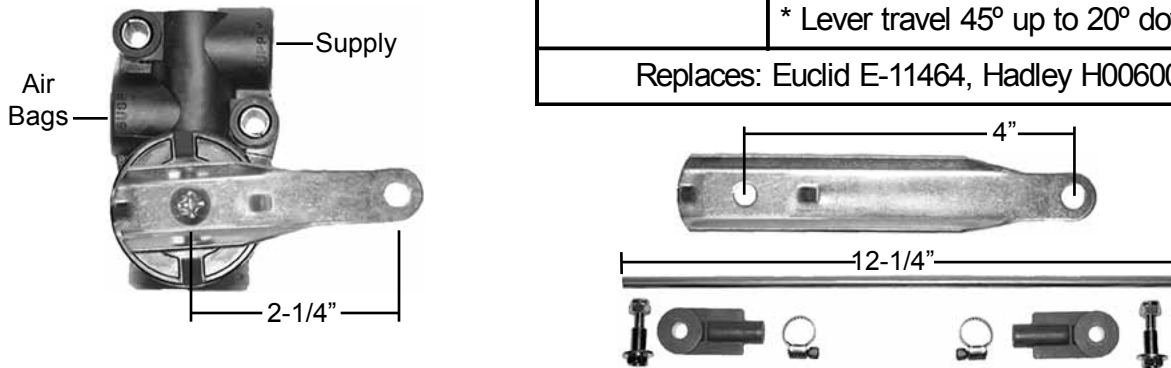

Propriété exclusive de FleetSpec. Toute reproduction interdite. / Exclusive property of FleetSpec. Reproduction prohibited.

Section 6 : Soupapes de suspension à air
 : Suspension Air Valves

**Soupapes de contrôle de niveau
 Height Control Valves**

New	Notes
FS-6585	* Fast Response, High Airflow design * 4 (1/4" PT) Ports.
Replaces: Hendrickson Trailer VS-227, A-28651 Barksdale 52321-Q195	

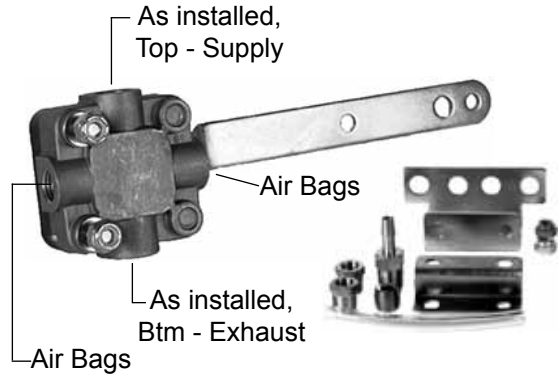
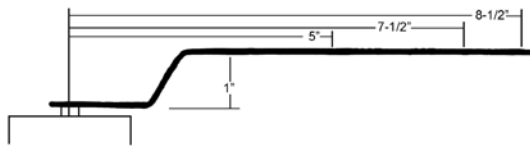

New	Notes
FS-6603	* Fast Response, High Airflow design * 4 (1/4" PT) Ports.
Replaces: Barksdale 52321-Q29, Q113, Q197 Freightliner KD-2204	

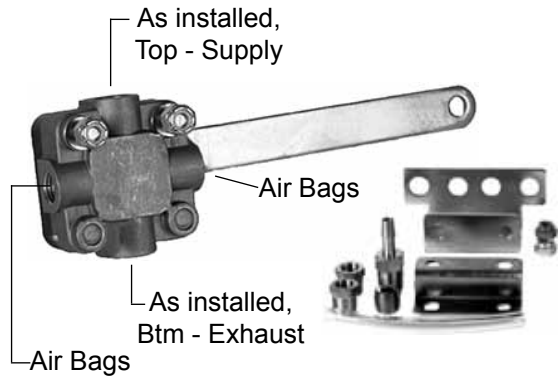

New	Notes
FS-6613	* Fast Response, High Airflow design * 4 (1/4" PT) Ports.
Replaces: Barksdale KD-2375, 52321-Q303 Hadley H00450CE	

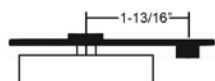

Section 6 . Soupapes de suspension à air
Suspension Air Valves

**Soupapes de contrôle de niveau
Height Control Valves**

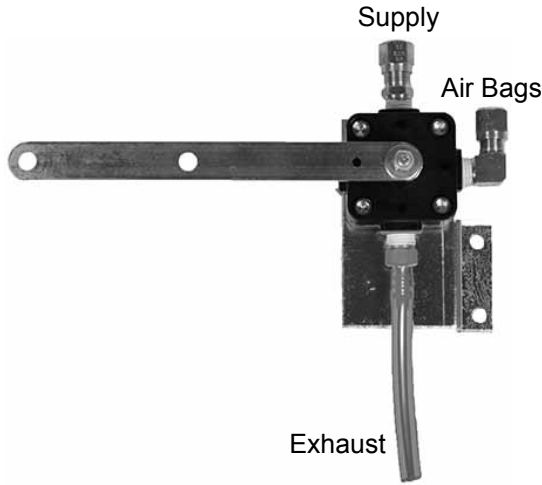

New	Notes
FS-6616	* Fast Response, High Airflow design * 4 (1/4" PT) Ports. * Mounting Bracket and Compression Fittings pre-installed.
Replaces: Barksdale 52321-Q321 Manac 073-007	

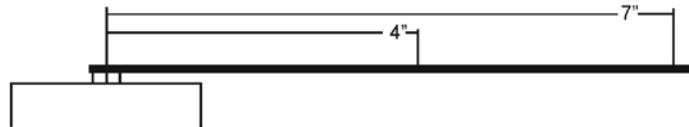

New	Notes
FS-6619	* Fast Response, High Airflow design * 4 (1/4" PT) Ports
Replaces: Barksdale KD2290; KD2356, 52321-Q295 Haldex KN27000 Wabco S443 002 443-0	



Section 6 • Soupapes de suspension à air
 • Suspension Air Valves

**Soupapes de contrôle de niveau
 Height Control Valves**

New	Notes
FS-6607	* Cab Height Control Valve * Fast Response, High Airflow design * Push-to-Connect Ports.
Replaces: Barksdale KD2262; 55521-Q103 Freightliner 13-37808-000	

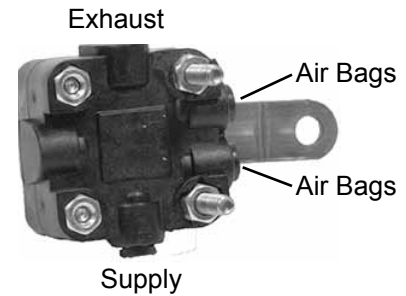
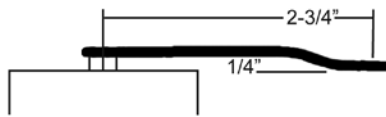

New	Notes
FS-6608	* Cab Height Control Valve * Fast Response, High Airflow design * Push-to-Connect Ports.
Replaces: Barksdale KD2168; 55521-Q35 Western Star 66007-3401	

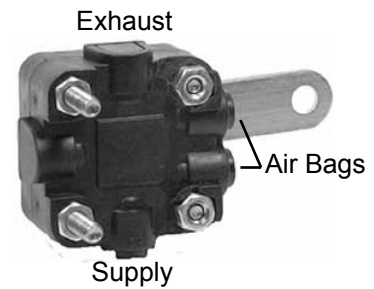
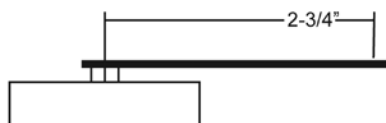

New	Notes
FS-6617	* Fast Response, High Airflow design * Push-to-Connect Ports
Replaces: Barksdale KD2355; 55521-Q149 Wabco S464 007 0040	

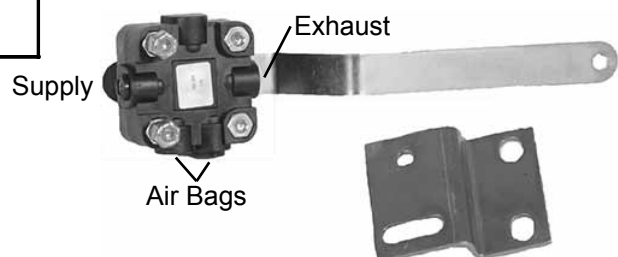
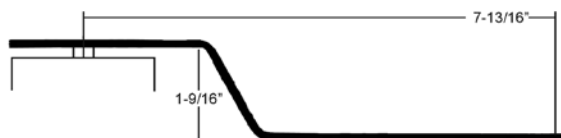

Propriété exclusive de FleetSpec. Toute reproduction interdite. / Exclusive property of FleetSpec. Reproduction prohibited.

Section 6 . Soupapes de suspension à air Suspension Air Valves

Soupapes de contrôle de niveau Height Control Valves

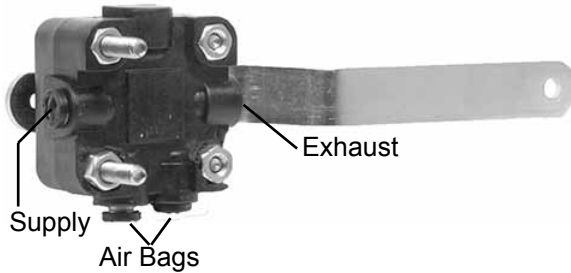

New	Notes
FS-6618	* Fast Response, High Airflow design * Push-to-Connect Ports
Replaces: Barksdale KD2261; 55521-Q87 Freightliner 18-30630-000	



Section 6 • Soupapes de suspension à air
 • Suspension Air Valves

**Soupapes de contrôle de niveau
 Height Control Valves**

New	Notes
FS-6591	* Fast Response, High Airflow design * Integral Dump Valve. (N.C.) * 5 (1/4" PT) Ports.
Replaces: Hendrickson 57977-000, 60501-000 Barksdale 52341-Q123, KD2265 KD2315 Euclid E-11870	

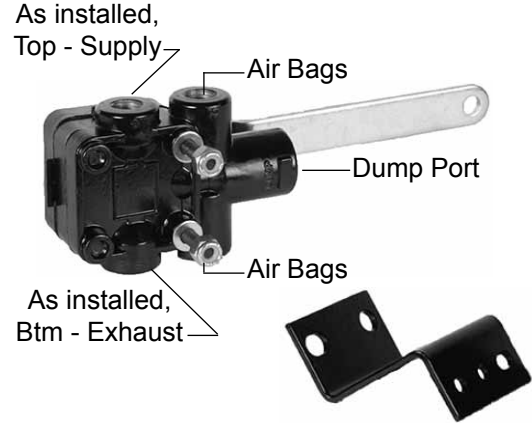
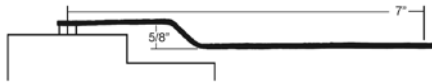

New	Notes
FS-6592	* Fast Response, High Airflow design * Integral Dump Valve. (N.C.) * 5 (1/4" PT) Ports.
Replaces: Barksdale KD2205, Volvo 3188710 Freightliner 16-14318-000	

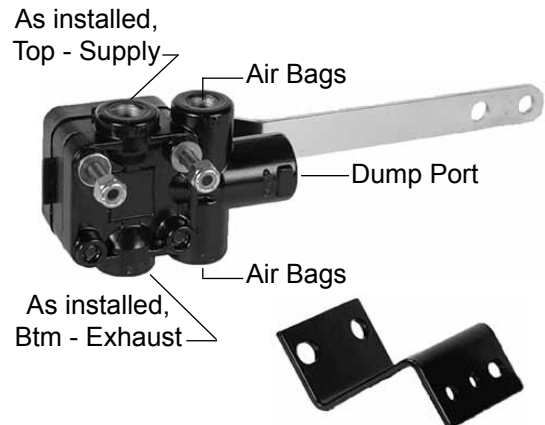
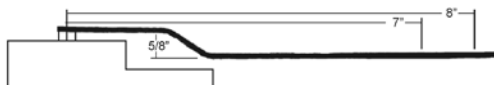

New	Notes
FS-6600	* Fast Response, High Airflow design * Integral Dump Valve. (N.C.) * 5 (1/4" PT) Ports.
Replaces: Peerless Trailer 52341-Q115	

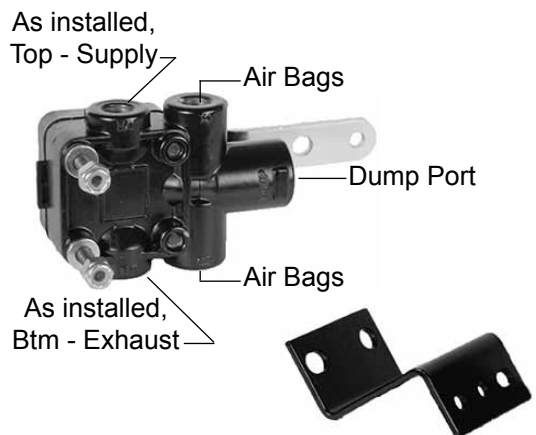
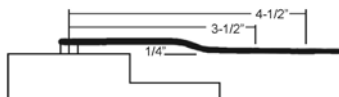

Section 6 . Soupapes de suspension à air . Suspension Air Valves

Soupapes de contrôle de niveau Height Control Valves

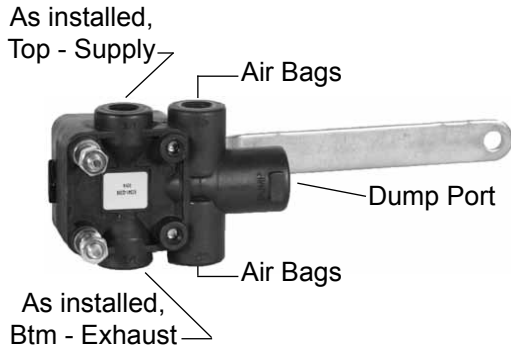

New	Notes
FS-6610	* Fast Response, High Airflow design * Integral Dump Valve. (N.C.) * 5 (1/4" PT) Ports.
Replaces: Barksdale KD-2360, 52341-Q206 Hadley HAD500NS International 2506169C91	

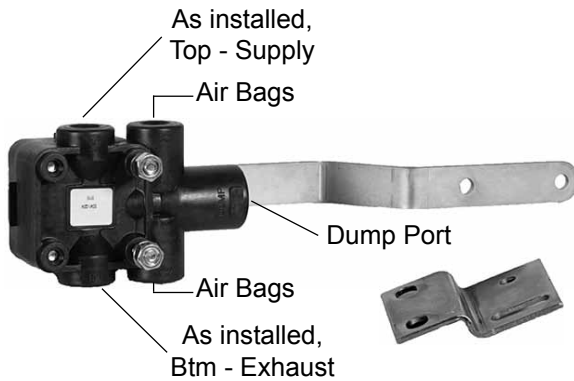
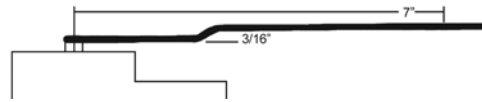

New	Notes
FS-6611	* Fast Response, High Airflow design * Integral Dump Valve. (N.C.) * 5 (1/4" PT) Ports.
Replaces: Barksdale KD-2358, 52341-Q204 Hadley H00500RS	

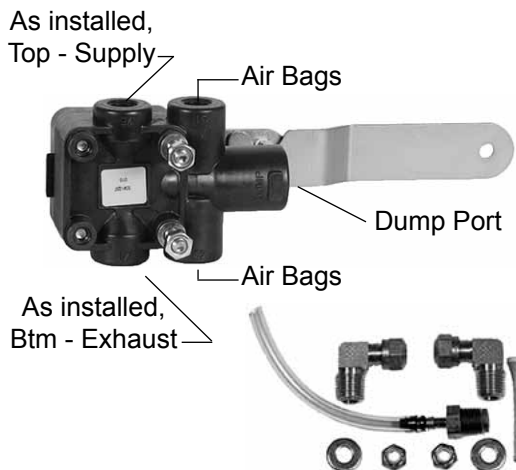

New	Notes
FS-6612	* Fast Response, High Airflow design * Integral Dump Valve. (N.C.) * 5 (1/4" PT) Ports.
Replaces: Barksdale: KD-2374, KD-2445, 52341-Q207 Haldex: G90-10199-095, G90-10919-99, PR 90554950, 90554945	



Section 6 : Soupapes de suspension à air
 : Suspension Air Valves

**Soupapes de contrôle de niveau
 Height Control Valves**

New	Notes
FS-6614	* Fast Response, High Airflow design * Integrated Dump Port (NC) * 5 (1/4" PT) Ports.
Replaces: Barksdale KD2228, Hendrickson S9890-000 Peterbilt 08-03315, Volvo 2516S691	

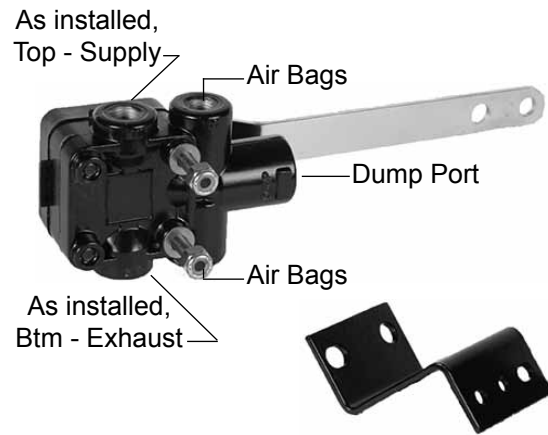

New	Notes
FS-6615	* Volvo trucks, 2006 and newer. * Fast Response, High Airflow design * Integrated Dump Port (NC) * Hook-Up Kit included. * 5 (1/4PT) Ports
Replaces: Barksdale KD2503 Haldex / Hadley 4 Bag HCV Volvo 85144423	

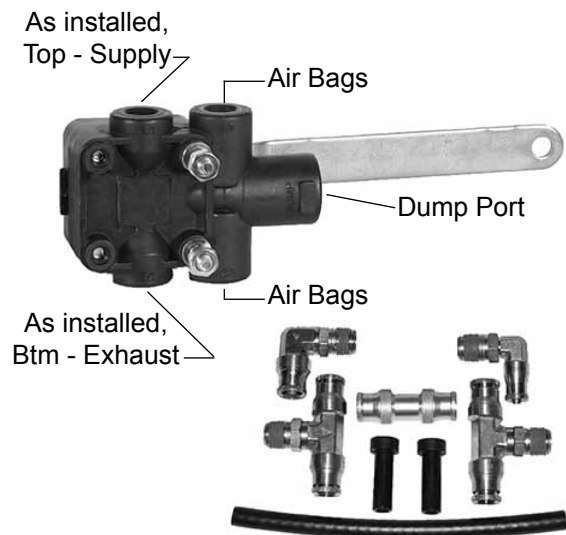

New	Notes
FS-6621	* Fast Response, High Airflow design * Integrated Dump Port (NC) * Includes Exhaust Hose & Hose Barb * 5 (1/4PT) Ports * Can also upgrade to FS-6614 (OE version)
Replaces: Barksdale KD2422, 52341-Q242 Peterbilt HV9990, TRP HV9990	

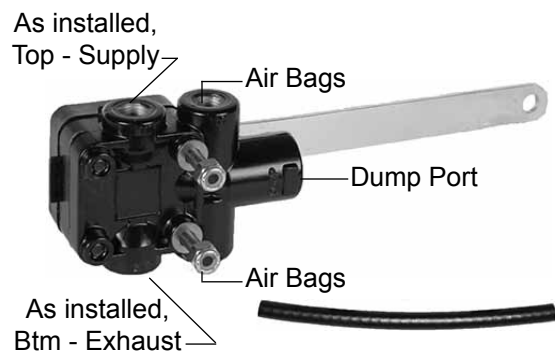
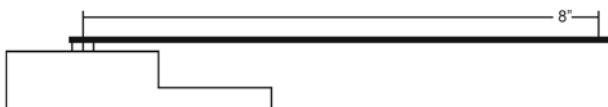

Compatible avec
Compatible with

**Barksdale &
Henderson**

"Votre source pour tous vos pièces neuves et remanufacturées depuis 1996"
"Your trusted source for quality New & Reman air components since 1996"

Section 6 . Soupapes de suspension à air Suspension Air Valves

Soupapes de contrôle de niveau Height Control Valves

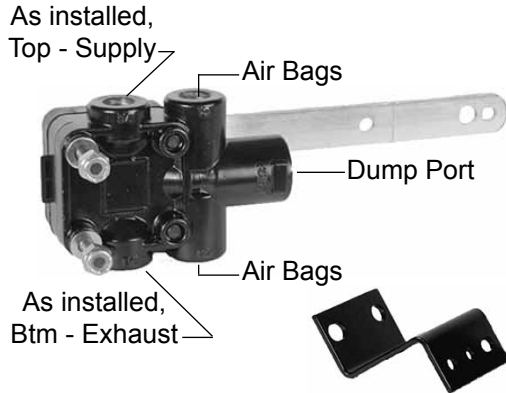

New	Notes
FS-6602	<ul style="list-style-type: none"> * Fast Response, High Airflow design * Integral Dump Valve. (N.O. - needs air applied to operate levelling) * Works with Trailer Parking Brakes. * 5 (1/4" PT) Ports.
Replaces: Hendrickson Trailer VS-228, A-29391	

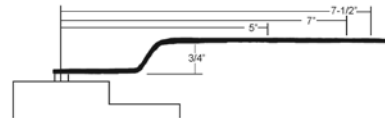

Compatible avec
Compatible with

Meritor / Wabco

"Votre source pour tous vos pièces neuves et remanufacturées depuis 1996"
"Your trusted source for quality New & Reman air components since 1996"

Soupapes de contrôle de niveau Height Control Valve



New	Notes
FS-6540	<ul style="list-style-type: none"> * Cab Height Control Valve * Protective Rubber Boot included * 2 (1/4P-T-C) Ports
Replaces: Barksdale KD2291, Dayton K862001 PrimaBrands LV70040 Meritor/Wabco MTR S4640070040	

FleetSpec

Section 6 • Soupapes de suspension à air • Suspension Air Valves

Tiges pour les soupapes de contrôle de niveau Linkages for Height Control Valves

New	Notes
FS-6594	* 18" Straight Rod. * Easily cuts down for any install.
Replaces: Neway SRK168, 48100225	
FS-6594R	"Lollipop" rubber link <only>
Replaces: Haldex 90054516	

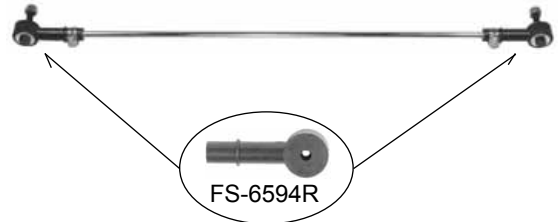

New	Notes
FS-6595	* Maximum 21" C to C * Easily adjusts for any install.
Replaces: Hendrickson/Turner A14187 Hendrickson S-14187	

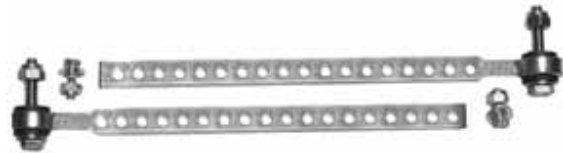

New	Notes
FS-6678	* 14-1/2" Straight Rod. * 12-1/2" L Rod. * Easily adjusts for any install.
Replaces: Neway SRK205, 48100867	
FS-6678RE	"Elbow" rubber link <only>
Replaces: Haldex 90054630	
FS-6678R	"Lollipop" rubber link <only>
Replaces: Haldex 90054670	

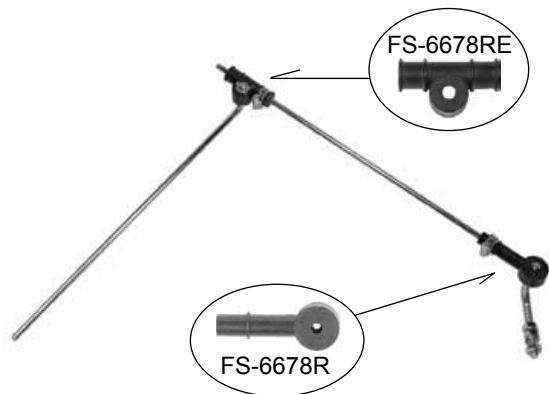

New	Notes
FS-6598	* Replacement kit for Haldex KN27000 Height Control Valve * Easily adjusts for any install.

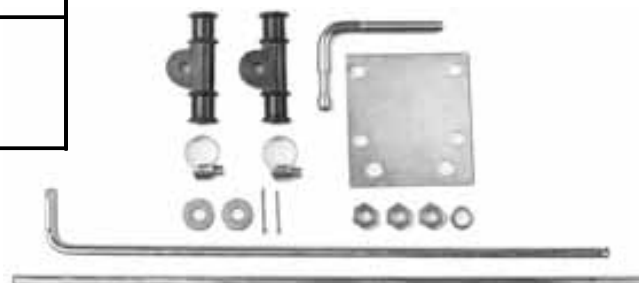

Section 6 : Soupapes de suspension à air Suspension Air Valves

Modules de contrôle pour essieu relevable Lift Axle Control Modules

Lift Axle Control Modules

These chassis-mounted Lift Axle Control Modules are specifically designed for the heavy-duty truck and trailer industry. They provide full pneumatic control of the lift axle. These modules contain two industry proven brake-style relay valves, integrated into a single unit for compactness and ease of installation.

These modules provide excellent flow capacity for rapid lift axle operation.

More robust than the commonly used spool valves, which can suffer from contamination and temperature extremes.

Available with a control solenoid for electric operation.

*Note: If an air gauge is not used, simply plug the gauge port.

GTD5040-111-01C

Air Actuated, with Check Valve
 * Replaces Ride-Air RA204

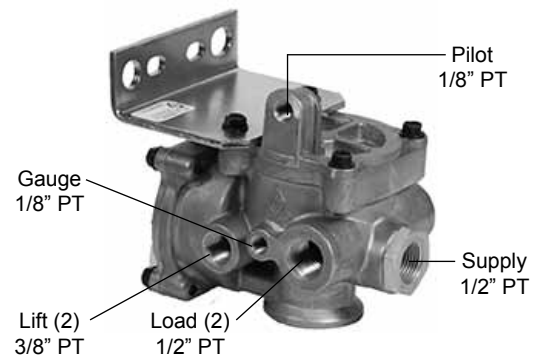

GTD5040-211-01C

12 Volt Solenoid Actuated (N.O.)
 With Check Valve
 * Replaces Ride-Air RA206

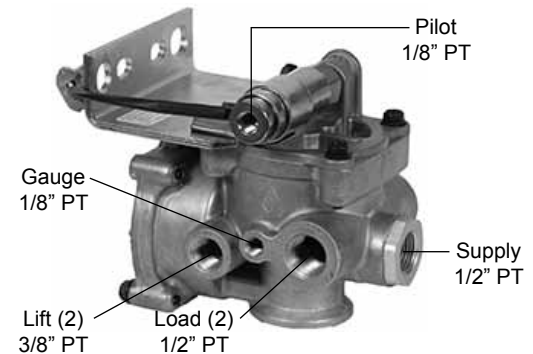

GTD5040-311-01C

12 Volt Solenoid Actuated (N.C.)
 With Check Valve
 * Replaces Ride-Air RA205

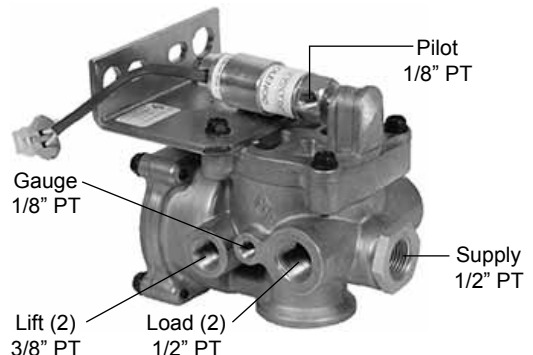

Section 6 • Soupapes de suspension à air • Suspension Air Valves

Soupapes de contrôle Control Valves

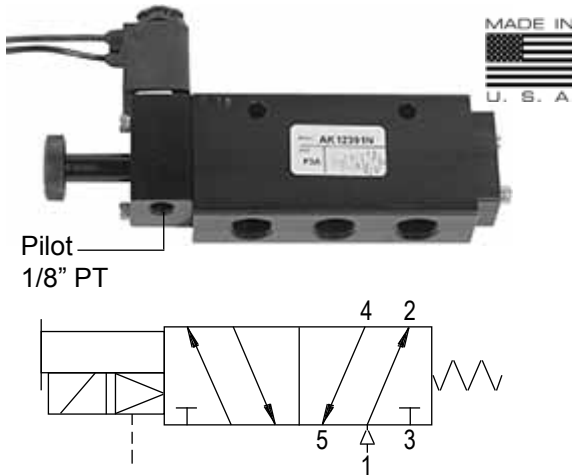

New	Notes
AK12391N	<ul style="list-style-type: none"> * 2 Position, 5 (3/8" PT) Port Valve. * 12 Volt Solenoid, Spring Return. * Manual (locking) Override. * 96 SCFM airflow (at full open). * External Pilot supply needed. * 40 PSI to 150 PSI Supply.
Replaces: Manac SP-4904 Ride-Air RA220-1	

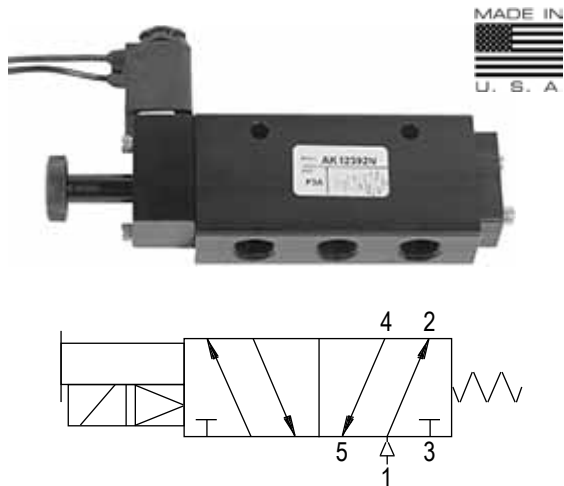

New	Notes
AK12392N	<ul style="list-style-type: none"> * 2 Position, 5 (3/8" PT) Port Valve. * 12 Volt Solenoid, Spring Return. * Manual (locking) Override. * 96 SCFM airflow (at full open). * Mesh screens in ports 1, 2 and 4. * 40 PSI to 150 PSI Supply.
Replaces: HD Plus ACW4944 Manac SP-4900, 223-6197 Ride-Air RA220	

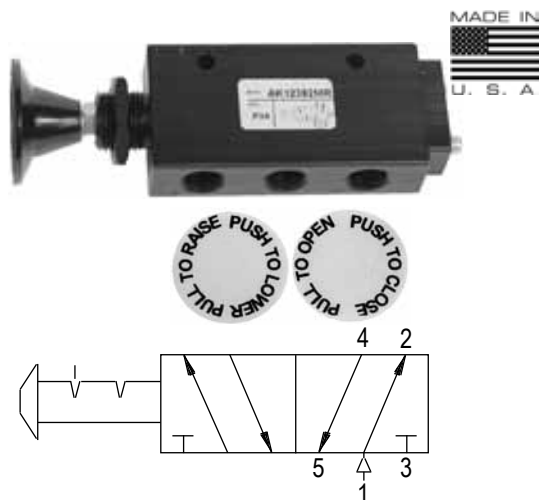

New	Notes
AK12392MR	<ul style="list-style-type: none"> * 2 Position, 5 (3/8" PT) Port Valve. * Fully Manual Operation. * 96 SCFM airflow (at full open). * Panel, inline, or thru hole mounting. * 200 PSI Max supply.
Replaces: Ride-Air RA221	

Section 6 • Soupapes de suspension à air
 • Suspension Air Valves

**Soupapes de contrôle
 Control Valves**

New	Notes
AK12392PR	<ul style="list-style-type: none"> * 2 Position, 5 (3/8" PT) Port Valve. * Manual operation, with air pilot reset. Detented in the out position. * 96 SCFM airflow (at full open). * Panel, inline, or thru hole mounting. * 200 PSI Max supply,. * 40 PSI Minimum for pilot pressure.
Replaces: Ride-Air RA222	
AK12392PR-1/4	As above, with 1/4" PT ports and 48 SCFM airflow
Replaces: Sealco 152000	

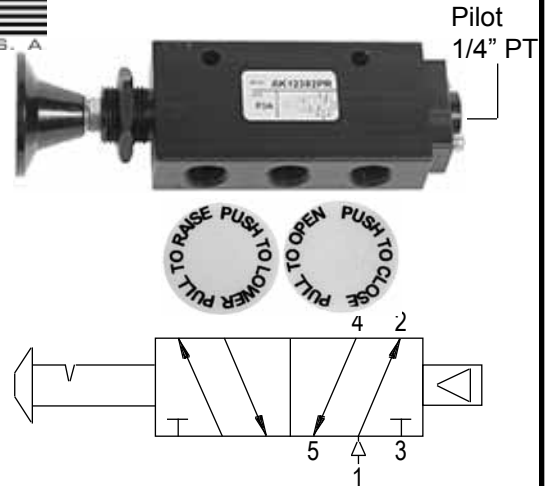

New	Notes
AK12393N	<ul style="list-style-type: none"> * 2 Position, 3 (3/8" PT) Port Valve. * Manual operation, with air pilot reset. Detented in the out position. * 96 SCFM airflow (at full open). * Panel, inline, or thru hole mounting. * 200 PSI Max supply,. * 40 PSI Minimum for pilot pressure.
Replaces: Manac 223-6204 Ride-Air RA222-3	

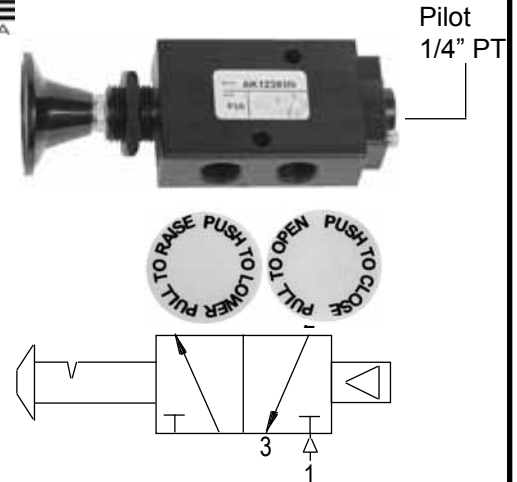

New	Notes
AK12394N	<ul style="list-style-type: none"> * 2 Position, 3 (3/8" PT) Port Valve. * Air pilot operation, Spring return. * 96 SCFM airflow (at full open). * Inline, or thru hole mounting. * 200 PSI Max supply,. * 40 PSI Minimum for pilot pressure.
Replaces: HD Plus ACW4948 Manac SP-4902, 223-6203, 223-6196 Ride-Air RA224-3	

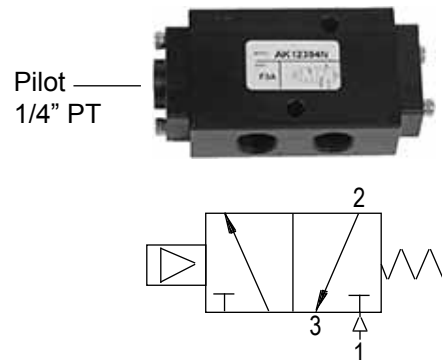

Section 6 • Soupapes de suspension à air • Suspension Air Valves

Soupapes de contrôle Control Valves

Pilot
1/4" PT

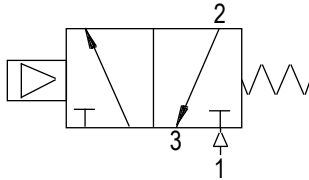

New	Notes
AK12394-1/4	<ul style="list-style-type: none"> * 2 Position, 3 (1/4" PT) Port Valve. * Air pilot operation, Spring return. * 48 SCFM airflow (at full open). * Inline, or thru hole mounting. * 200 PSI Max supply,. * 40 PSI Minimum for pilot pressure.
Replaces: Norgren K41DA00KS1KA-2	

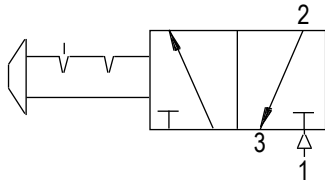

New	Notes
AK12395N	<ul style="list-style-type: none"> * 2 Position, 3 (3/8" PT) Port Valve. * Fully Manual Operation. * 96 SCFM airflow (at full open). * Panel, inline, or thru hole mounting. * 200 PSI Max supply.
Replaces: Ride-Air RA221-3	

Pilot
1/4" PT

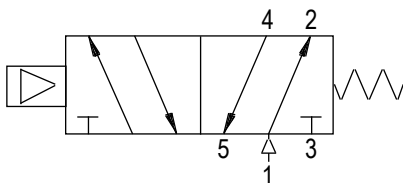

New	Notes
AK12396N	<ul style="list-style-type: none"> * 2 Position, 5 (3/8" PT) Port Valve. * Air pilot operation, Spring return. * 96 SCFM airflow (at full open). * Inline, or thru hole mounting. * 200 PSI Max supply,. * 40 PSI Minimum for pilot pressure.
Replaces: Ride-Air RA224	

Section 6 : Soupapes de suspension à air
 : Suspension Air Valves

Soupapes de contrôle
Control Valves

New	Notes
AK12401N	<ul style="list-style-type: none"> * 2 Position, 3 (3/8" PT) Port Valve. * Manual operation, with air pilot reset. Detented in the out position. * 96 SCFM airflow (at full open). * Panel, inline, or thru hole mounting. * 200 PSI Max supply. * 40 PSI Minimum for pilot pressure. * Mini Black Knob.
Replaces: HD Plus ACW4946 Manac SP-4901, 223-6204	

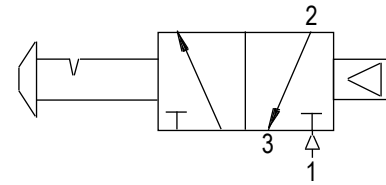

New	Notes
AK12402N	Air Control Valve, with Air Reset for use in FS-6967-6A Suspension Dump Control Box.



New	Notes
AK12403N	Air Control Valve (full manual), for use in FS-6967-6B Suspension Dump Control Box.



New	Notes
AK12404N	<ul style="list-style-type: none"> * 2 Position, 5 (1/8" PT) Port Valve. * Fully Manual Operation. * Panel, inline, or thru hole mounting.
Replaces: Airman 2400-628 (Talbert Lowboy)	

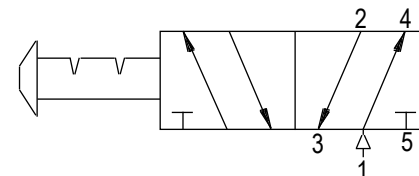

Section 6 . Soupapes de suspension à air Suspension Air Valves

Soupapes de contrôle Control Valves

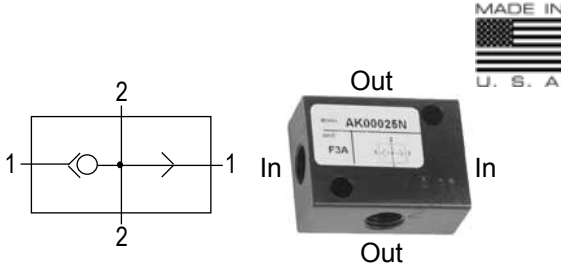

New	Notes
AK00025N	<ul style="list-style-type: none"> * 4 (1/4" PT) Ports * Thru hole mounting. * 10 to 150 PSI operation.
Replaces: Norgren T65A2800	

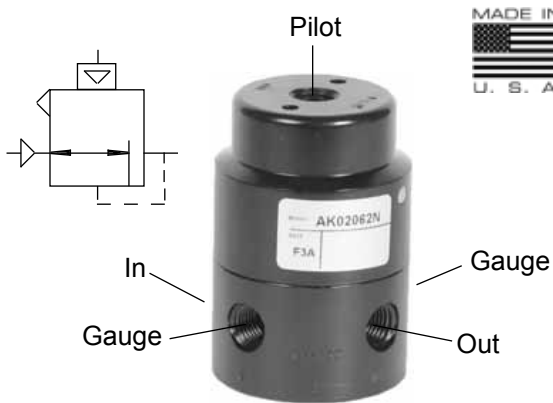

New	Notes
AK02062N	<ul style="list-style-type: none"> * 2:1 Ratio Regulator. * 5 (1/4" PT) Ports. - 2 for optional Air Gauge use. * Outputs 50 % of Signal Pressure. * Designed to regulate a Steer Axle with Torpress Air Bag.
Replaces: Ride-Air RA6210	



New	Notes
AK12391A	Replacement Actuator for AK12391N



New	Notes
AK12392S	Replacement Solenoid Coil for AK12391N or AK12392N Valves
Replaces: Ride-Air RA220A	



New	Notes
AK12392SP	Replacement Spool for AK12391N or AK12392N Control Valves
Replaces: Ride-Air RA220C	

Section 6 : Soupapes de suspension à air
 : Suspension Air Valves

**Soupapes de contrôle
 Control Valves**

New	Notes
RA12391N	<ul style="list-style-type: none"> * 2 Position, 5 (3/8" PT) Port Valve. * 12 Volt Solenoid, Spring Return. * Manual (locking) Override. * Manual or Electric operation. * 1/8" Pilot Port * External pilot supply needed for electrical operation
Replaces: Ride-Air RA020-1	



New	Notes
RA12392N	<ul style="list-style-type: none"> * 2 Position, 5 (3/8" PT) Port Valve. * 12 Volt Solenoid, Spring Return. * Manual (locking) Override. * Manual or Electric operation. * Internal Pilot Supply
Replaces: Ride-Air RA020	



New	Notes
RA12392S	Replacement Solenoid Coil for RA12391N or RA12392N Valves
Replaces: Ride-Air RA020A	



New	Notes
RA12392SP	Replacement Spool Kit for RA12391N or RA12392N Valves
Replaces: Ride-Air RA020C	



Section 6 . Soupapes de suspension à air . Suspension Air Valves

Soupapes de contrôle - Série Nugget 200 Nugget 200 series Control Valves



NORK910019

- * 2 Position, 5 (3/8" PT) Port Valve.
- * 12 Volt Solenoid, Spring Return.
- * Manual (locking) Override.
- * Pilot air needed for electric operation
- * Solenoid on 3 port side of valve.



NORK910014

- * 2 Position, 5 (3/8" PT) Port Valve.
- * 12 Volt Solenoid, Spring Return.
- * Manual (locking) Override.
- * Solenoid on 2 port side of valve.

Pilot
1/8" PT



NORK910054

- * 2 Position, 3 (3/8" PT) Port Valve.
- * Manual Operation, Pilot Return.

Replaces: Manac 223-6195

Control
1/8" PT



NORK41EA00KS6KA2

- * 2 Position, 3 (3/8" PT) Port Valve.
- * Air Operated, Spring Return.

Replaces: Manac 023-2995, 223-6196



NORK910038

- * 2 Position, 3 (3/8" PT) Port Valve.
- * Fully Manual Operation.

Replaces: Manac 023-2996

Section 6 • Soupapes de suspension à air • Suspension Air Valves

Soupapes de contrôle - Série Nugget 200 Nugget 200 series Control Valves

NORK71EA00KS6KA2

- * 2 Position, 5 (3/8" PT) Port Valve.
- * Air Operated, Spring Return.

Replaces: Manac 023-2997

NORK71EA00KS6KV2

- * 2 Position, 5 (3/8" PT) Port Valve.
- * 12 Volt Solenoid, Spring Return..
- * Locking Override Knob.



Control
1/8" PT



Pièces de remplacement Nugget 200 Nugget 200 series Service Parts

New	Notes
NOR54237-56	* Replacement Spool Ass'y <only> for 5-Port Valves.



New	Notes
NOR54452-02	* 12 V Coil for NORK71EA00KS6KV2
NOR54932-26	* 12V Coil for NORK910014 & 19
NOR54932-27	* 24V Coil for NORK910014 & 19



NOR54452-02
illustrated here

New	Notes
NOR54933-06	* Replacement Electrical Cable, 6 feet, for NOR54932-26 & -27 coils



Section 6 • Soupapes de suspension à air • Suspension Air Valves

Soupapes de contrôle Control Valves



New	Notes
NG12391N	<ul style="list-style-type: none"> * 2 Position, 5 (3/8" PT) Port Valve. * 12 Volt Solenoid, Spring Return. * Manual (locking) Override. * Pilot air needed for electric operation * Solenoid on 3 port side of valve.
Replaces: Norgren K910019 Haldex 90554662 Tectran 29-SS6E	



New	Notes
NG12392N	<ul style="list-style-type: none"> * 2 Position, 5 (3/8" PT) Port Valve. * 12 Volt Solenoid, Spring Return. * Manual (locking) Override. * Solenoid on 2 port side of valve.
Replaces: Norgren K910014 Manac 023-299, 223-6197 Tectran 29-SS6M	

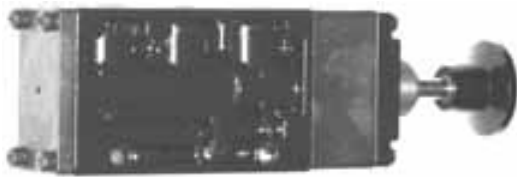

New	Notes
NG12392MR	<ul style="list-style-type: none"> * 2 Position, 5 (3/8" PT) Port Valve. * Fully Manual Operation.
Replaces: Parker 52043-1000	

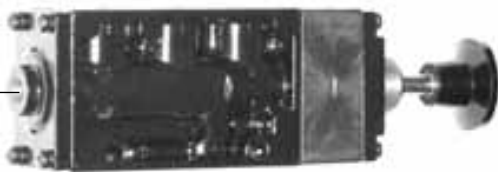

New	Notes
NG12392PR	<ul style="list-style-type: none"> * 2 Position, 5 (3/8" PT) Port Valve. * Manual Operation, Pilot Return.
Replaces: Parker 52045-1000	

Section 6 : Soupapes de suspension à air
 : Suspension Air Valves

Soupapes de contrôle
Control Valves

New	Notes
NG12392SR	* 2 Position, 5 (3/8" PT) Port Valve. * Manual Operation, Spring Return.
Replaces: Parker 52041-1000	

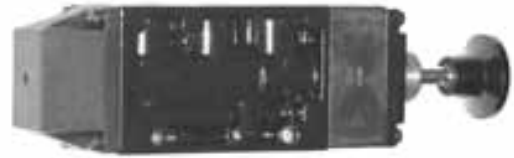

New	Notes
NG12393N	* 2 Position, 3 (3/8" PT) Port Valve. * Manual Operation, Pilot Return.
Replaces: Norgren K910054 Air-Max 02400188 Manac 223-6195	



Pilot
 1/8" PT

New	Notes
NG12394N	* 2 Position, 3 (3/8" PT) Port Valve. * Air Operated, Spring Return.
Replaces: Norgren K41EA00KS6KA2 Manac 023-2995, 223-6196	



Control
 1/8" PT

New	Notes
NG12395N	* 2 Position, 3 (3/8" PT) Port Valve. * Fully Manual Operation.
Replaces: Norgren K910038 Manac 023-2996 Parker M08531826	



New	Notes
NG12396N	* 2 Position, 5 (3/8" PT) Port Valve. * Air Operated, Spring Return.
Replaces: Norgren K71EA00KS6KA2 Manac 023-2997	

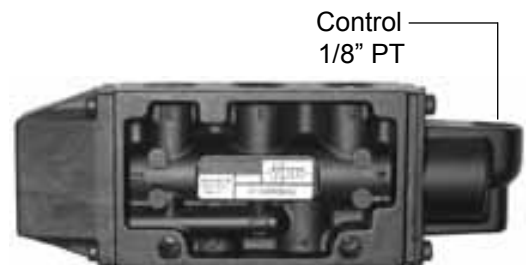

Control
 1/8" PT

Section 6 . Soupapes de suspension à air Suspension Air Valves

Soupapes de contrôle Control Valves



New	Notes
NG12398N	* 2 Position, 5 (3/8" PT) Port Valve. * 12 Volt Solenoid, Spring Return. * Pilot Port (35-150 PSI).
Replaces: Norgren K71EA00KS6KWW Velvac 320130	



New	Notes
NG12399N	* 2 Position, 5 (3/8" PT) Port Valve. * 12 Volt Solenoid, Spring Return.. * Locking Override Knob.
Replaces: Norgren K71EA00KS6KV2 Velvac 320131	



New	Notes
NG12410N	* 2 Position, 3 (3/8" PT) Port Valve. * 12 Volt Solenoid, Spring Return. * Normally Open, Quick Response
Replaces: Norgren K910027 Can replace FS-4523, when higher airflow is needed	



New	Notes
NG12411N	* 2 Position, 3 (3/8" PT) Port Valve. * Manual Operation, Spring Return.

Section 6 : Soupapes de suspension à air
 : Suspension Air Valves

**Soupapes de contrôle
 Control Valves**

New	Notes
NG12392S	* Manual / Electric replacement actuator for NG12391N & NG12392N
NG12392-C	* Replacement Solenoid Coil <only> for NG12391, 12392 & 12399
NG12392W	Replacement Electrical Socket and Cable for NG12391, 12392 & 12399 * 6 Foot Cable * Includes Gasket and Screw
NG12397	* Replacement Knob <only> for NG12391N, NG12392N
NG12392SP	* Replacement Spool <only> for NG12391, 92, 96, 98, 99

New	Notes
NG12398S	Replacement Actuator for NG12398N
NG12398C	Replacement Coil <only>

New	Notes
NG12399S	Replacement Actuator for NG12399N

New	Notes
NG12400	Replacement "Palm" Knob for NG12392MR, SR, PR, NG12393, 95
NG616-10	Replacement panel-mount Nut for NG12392MR, PR, SR, NG12393, 95

New	Notes
FS-70-2120	* Breather Fitting, 1/8" PT
FS-70-2140	* Breather Fitting, 1/4" PT
FS-70-2160	* Breather Fitting, 3/8" PT



Section 6 . Soupapes de suspension à air Suspension Air Valves

Solénoïde électrique à 4-voie 4-Way Electrical Solenoid Valve

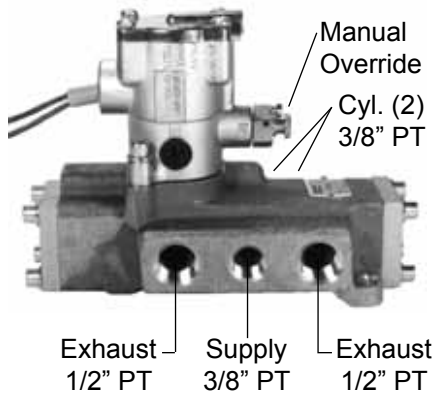

New	Notes
SH12387N	* 2 Position, 5 Port Valve. * 12 Volt Solenoid.
Reman SH12387X	* Manual (locking) Override. * 35 to 140 PSI operation. * 19" long wire, bare ends.
Replaces: Schrader L7053310445 Hendrickson A-12502-021 Tectran 27-S5331	
SH12387EC	End-Cover Repair Kit, with cover, air filter, end-gasket and 4 screws.

New	Notes
SH12387S	* 12 Volt replacement Solenoid. * "Special" -or- Continuous Service. * Manual (locking) Override. * 19" long wire, bare ends. * SH12387MG Metal Gasket included
Replaces: Schrader K085302545 Hendrickson A-12502-031 Tectran 27-K853025	

New	Notes
SH12387SK	* Service Kit to rebuild the Solenoid

New	Notes
SH12387MG	* replacement Metal Gasket for Solenoid mount.

New	Notes
SH12387GK	* Service Kit, to rebuild Solenoid and Spool components. * Our kit includes the SH12387MG replacement Metal Gasket, for improved performance.
Replaces: Schrader K352125 Hendrickson A-12502-023 Tectran 27-K5331RK	

Section 6 • Soupapes de suspension à air • Suspension Air Valves

Soupapes de contrôle Control Valves

New	Notes
NG12401N	<ul style="list-style-type: none"> * Air Control Valve for Self-Steer Axle. * 12 Volt, with Pilot Air Supply. * Manual Override knob.
Replaces: DeLoupe 30CODEL000	

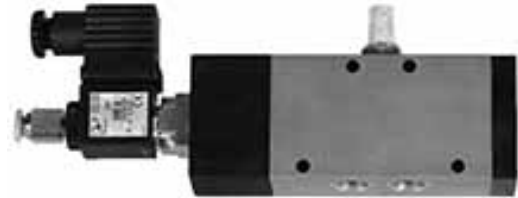

New	Notes
AK12391N	<ul style="list-style-type: none"> * 2 Position, 5 (3/8" PT) Port Valve. * 12 Volt Solenoid, Spring Return. * Manual (locking) Override. * 96 SCFM airflow (at full open). * External Pilot supply needed. * 40 PSI to 150 PSI Supply.
Replaces: Manac SP-4904 Ride-Air RA220-1	



Pilot
1/8" PT

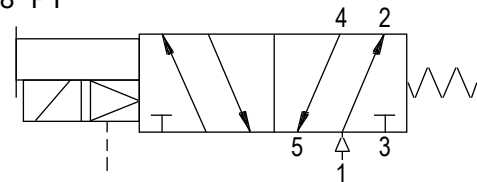

New	Notes
AK12394N	<ul style="list-style-type: none"> * 2 Position, 3 (3/8" PT) Port Valve. * Air pilot operation, Spring return. * 96 SCFM airflow (at full open). * Inline, or thru hole mounting. * 200 PSI Max supply. * 40 PSI Minimum for pilot pressure.
Replaces: HD Plus ACW4948 Manac SP-4902, 223-6203, 223-6196 Ride-Air RA224-3	



Pilot
1/4" PT

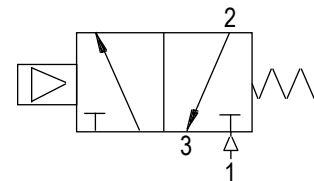

Section 6 • Souppes de suspension à air
• Suspension Air Valves

**Souppes de contrôle
Control Valves**

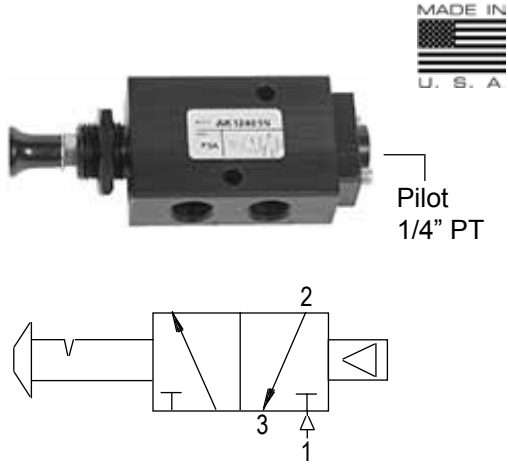

New	Notes
AK12401N	<ul style="list-style-type: none"> * 2 Position, 3 (3/8" PT) Port Valve. * Manual operation, with air pilot reset. Detented in the out position. * 96 SCFM airflow (at full open). * Panel, inline, or thru hole mounting. * 200 PSI Max supply. * 40 PSI Minimum for pilot pressure. * Mini Black Knob.
Replaces: HD Plus ACW4946 Manac SP-4901, 223-6204	

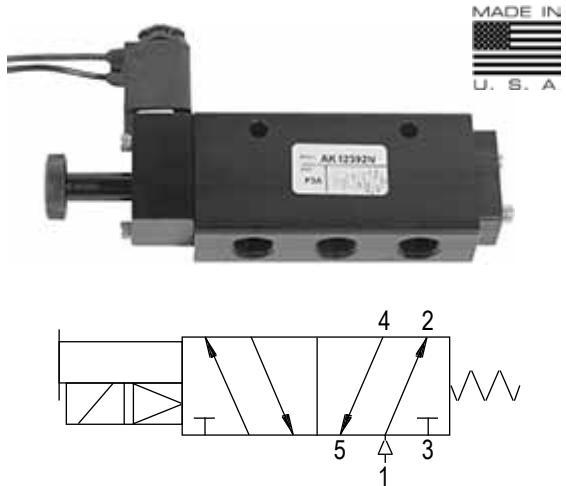

New	Notes
AK12392N	<ul style="list-style-type: none"> * 2 Position, 5 (3/8" PT) Port Valve. * 12 Volt Solenoid, Spring Return. * Manual (locking) Override. * 96 SCFM airflow (at full open). * Mesh screens in ports 1, 2 and 4. * 40 PSI to 150 PSI Supply.
Replaces: HD Plus ACW4944 Manac SP-4900, 223-6197 Ride-Air RA220	



New	Notes
FS-5181	<ul style="list-style-type: none"> * 2 Position, 5 (1/4" PT) Port Valve. * 12 Volt Solenoid * Breather Fittings in ports 3 and 5.
Replaces: Apsco VE-2, Buyers BAV050SA, Tectran 29SS4, Velvac 320131, 320178	
FS-5181-C	Replacement Solenoid Coil <only>

Section 6 • Soupapes de suspension à air • Suspension Air Valves

Soupape 3-voie à retour automatique 3-Way Auto Reset Control Valves

New	Notes
FS-5177	* 1/4" Breather Fitting included.
Replaces: Hendrickson VS-25223	

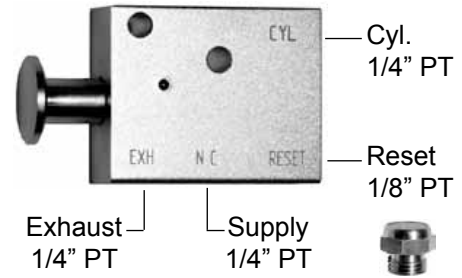

New	Notes
FS-5182	* Exhaust tube and all Compression fittings are included.
Replaces: Hendrickson VS-25224	



Soupape 3-voie à retour automatique Air Suspension Dump Control Valve

New	Notes
FS-5188	* 90° Fitting and Exh. Tube included.
Replaces: Hendrickson VS-30428, AKEM0005-1	

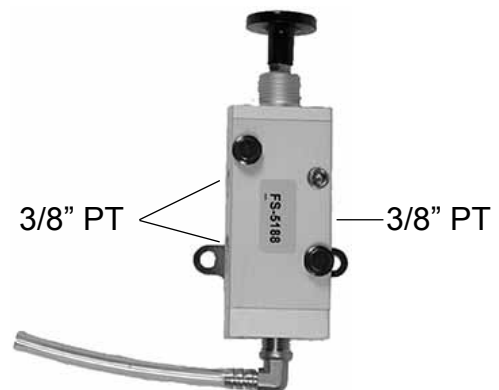

Section 6 • Soupapes de suspension à air • Suspension Air Valves

Valves de protection Pressure Protection Valves



New	Notes
FS-5183	* Normally Closed. Opens at 75 PSI.
Replaces: Hendrickson VS-1128	



New	Notes
FS-6596	* Normally Closed. Opens at 70 PSI. * Max. operating pressure: 150 PSI. * with Filter in Inlet Port.
Replaces: Williams WM778A1, 118181 Manac 023-150	



New	Notes
FS-6596N	* Normally Closed. Opens at 75 PSI. * Max. operating pressure: 150 PSI.
Replaces: Neway N90554107 Manac 023-290	



New	Notes
FS-6597	* Normally Closed. Opens at 75 PSI. * Max. operating pressure: 150 PSI.
Replaces: Haldex KN31171 Hendrickson A14149	

Section 6 • Soupapes de suspension à air • Suspension Air Valves

Robinets à 3-vois 3-Way Diverter Valves

New	Notes
FS-5174	* All ports (3) are 1/4" PT * Brass housing, with Stainless Steel Ball (for corrosion resistance).
Replaces: Hendrickson A12502-025 Manac 223-292	

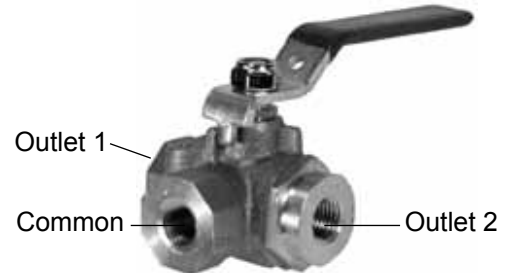

New	Notes
FS-5175	* All ports (3) are 1/4" PT * Brass housing, with Stainless Steel Ball (for corrosion resistance).
Replaces: Hendrickson A22535, VS-22535 Hendrickson AK147-1 Manac 073-034	
FS-5175K	Knob <only> for FS-5175

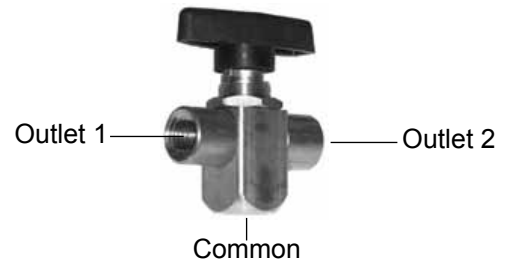

Soupape de contrôle manuel Manual Control Valve

New	Notes
FS-6580	* Both ports (2) are 1/8" PT * Brass housing for corrosion resistance.
Replaces: Dayton 334-1599; Euclid E4326; Manac 023-138; Neway 90054088	
FS-6580K	Knob <only> for FS-6580
Replaces: Neway 90054211	

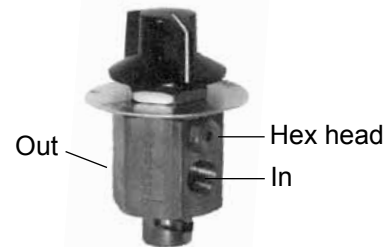

**** Important Note ****
 Reversed connections **WILL**
 cause this valve to leak.

Soupape de décharge rapide Rapid Dump Valve

New	Notes
FS-5176	* All ports (4) are 1/8" PT
Replaces: GT Dev. 4111, Sloan 401148 Tectran 91-8310, Velvac 032195	



Section 6 . Soupapes de suspension à air . Suspension Air Valves

Soupapes à commande par pilote Pilot Valves

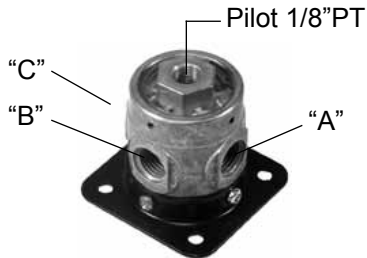

New	Notes	"A"	"B"	"C"
FS-6582	* Normally Open. * Replaces: Neway 90054079	Cyl	Exh	In
FS-6582NC	* Normally Closed.	In	Exh	Cyl
FS-6582U	* Normally Open <or> Closed * Replaces: Neway 90054615	Com	In N/C	In N/O

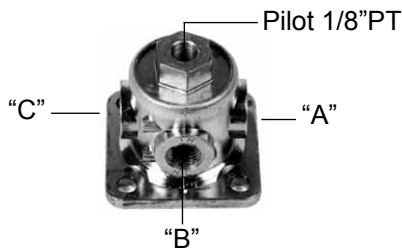

* Air piloted from 20 to 125 PSI. Ports "A" "B" and "C" are 1/4"
 * Commonly used for Service Line Override on Lift Axles.
 *** NOT intended for Brake System use ***

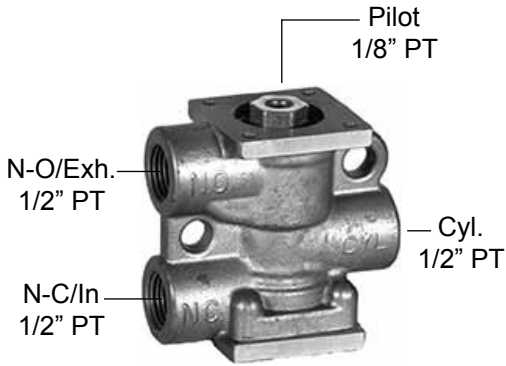

New	Notes
FS-HUM501A	* Two position, Spring Return * Mounts in any position * 275 CFM at 125 PSI
Replaces: Humphrey 501A	

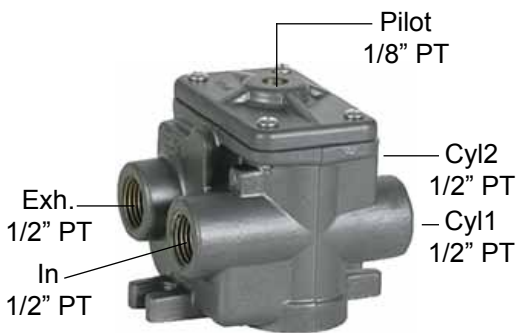

New	Notes
FS-HUM501-4A	* Two position, Spring Return, 4-Way * Mounts in any position * 212 CFM at 125 PSI
Replaces: Humphrey 501-4A	

Section 6 : Soupapes de suspension à air

Suspension Air Valves

Solénoïdes électrique à 3-voie

3-Way Electrical Solenoid Valves

New	Notes	"A" 1/4"	"B" 1/4"	"C" 1/4"
FS-4523 *	* 12 Volt, Normally Open. * Closes when Energized. * Replaces: Neway 90054075	In	Exh	Cyl
* Use NG12410N when higher airflow is required				
FS-6581	* 12 Volt, Normally Closed. * Opens when Energized. * Replaces: Neway 90054074	Exh	In	Cyl
FS-6576	* 12 Volt operation. * Normally open or closed. * Manual Override feature. * Replaces: Neway 90054076	Exh N/C	In N/C	Com

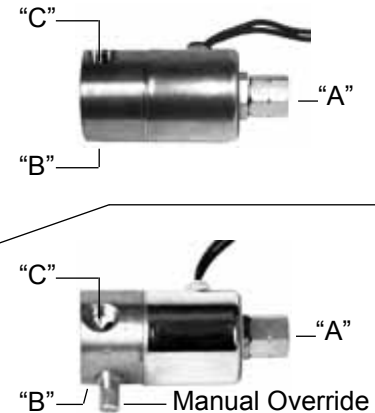

Valves relais

Relay Valves

New	Reman	Type	"A" 1/4" PT	"B" 1/8" PT	Closes @ PSI	Reopens @ PSI	Replaces Williams:
FSWM147C	--	NC	Control	Exhaust	--	15-30	111527
FSWM147F	--	NO	Exhaust	Control	30-50	15-30	111531
--	FSWM147LX	NC	Control	Exhaust	--	35-45	130845
FSWM147P	--	NO	Exhaust	Control	10-30	5-10	111542

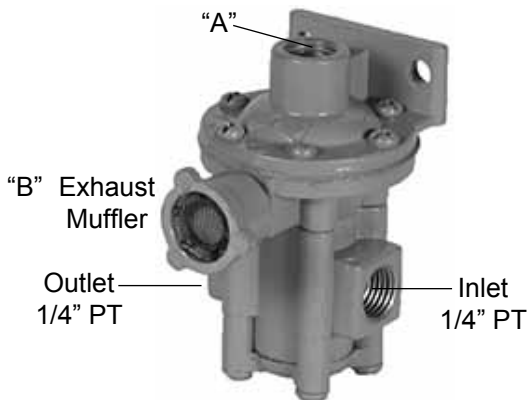

FSWM147C (and L) shown here

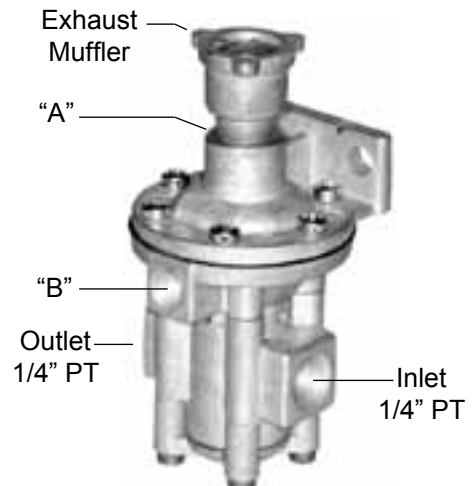

FSWM147F (and P) shown here

Propriété exclusive de FleetSpec. Toute reproduction interdite. / Exclusive property of FleetSpec. Reproduction prohibited.

Section 6 • Soupapes de suspension à air • Suspension Air Valves

Régulateurs de pression Pressure Regulators

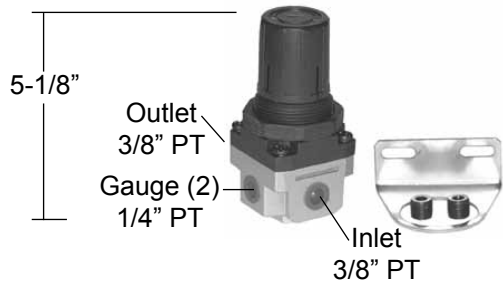

FS-12388
<ul style="list-style-type: none"> * 5-150 PSI regulating range. * 300 PSI max inlet pressure. * Reverse Flow feature * "Push-to-Lock" Adjusting Knob.

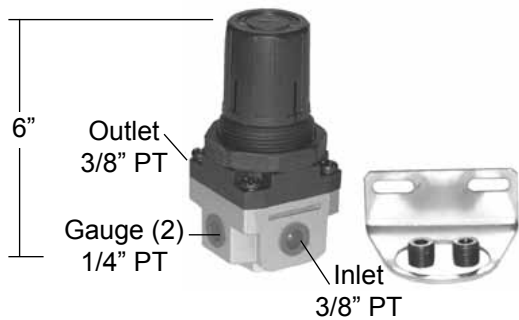

FS-12390
<ul style="list-style-type: none"> * 5-150 PSI regulating range. * 300 PSI max inlet pressure. * Reverse Flow feature. * "Push-to-Lock" Adjusting Knob.
Replaces: Haldex 90054864 Manac 023-3011 Norgren R73R-3AK-RMN Tectran 80-1200

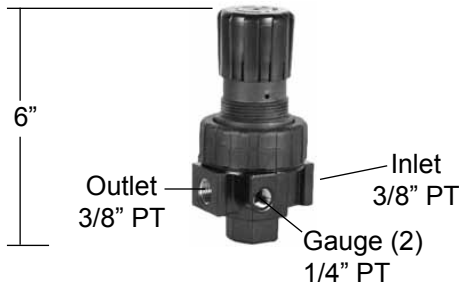

FS12392
<ul style="list-style-type: none"> * 0-125 PSI regulating range. * 250 PSI max inlet pressure. * Reverse Flow feature. * "Push-to-Lock", non-rising Adjusting Knob.
Replaces: Parker 06R213AC Schrader 035612000B Tectran 27-3561200

FS12393
Same specs as above. With 1/4"PT Inlet & Outlet Ports
Replaces: Parker 06R113AC

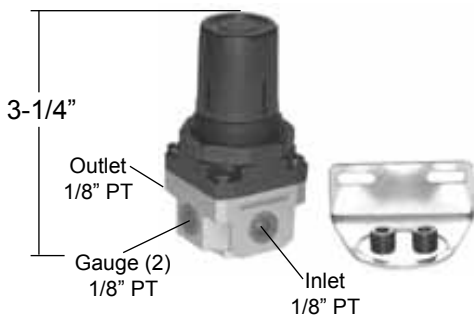

FS-6831
<ul style="list-style-type: none"> * 5-125 PSI regulating range. * 300 PSI max inlet pressure. * Reverse Flow feature. * "Push-to-Lock" Adjusting Knob.
Replaces: Granning 1066, Hendrickson VS1968 Manac 043-016, Parker 14R013FC Norgren R07-100-RNLA

Propriété exclusive de FleetSpec. Toute reproduction interdite. / Exclusive property of FleetSpec. Reproduction prohibited.

Section 6 : Soupapes de suspension à air Suspension Air Valves

Régulateurs de pression Pressure Regulators

NORR73R3AKRMN

- * 5-150 PSI regulating range.
- * 300 PSI max inlet pressure.
- * Reverse Flow feature
- * "Push-to-Lock" Adjusting Knob.

NOR4461-50

Neck Mounting Bracket for R73 series regulators.

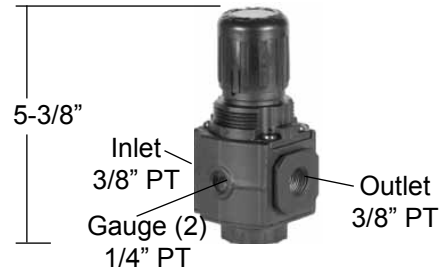

NORR72G2AKRMG

- * 5-150 PSI regulating range.
- * 300 PSI max inlet pressure.
- * Reverse Flow feature
- * "Push-to-Lock" Adjusting Knob
- * Includes Pressure Gauge

NOR74316-50

Neck Mounting Bracket for R72 series regulators

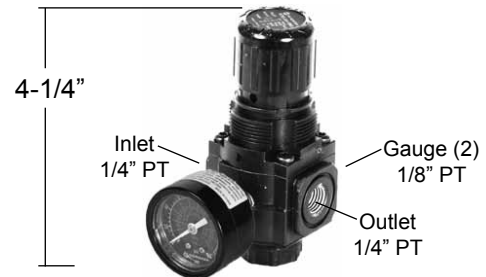

NORR07200RNLA

- * 0-125 PSI regulating range.
- * 300 PSI max inlet pressure.
- * Reverse Flow feature.
- * "Push-to-Lock" Adjusting Knob.

NORR07100RNLA

- * As above, with 4 1/8" PT Ports

NOR2962-04

- * Metal Panel Mount Nut for 07 Series regulators.

NOR18-025-003

- * Neck Mounding Bracket, with Plastic Nut for 07 series regulators.

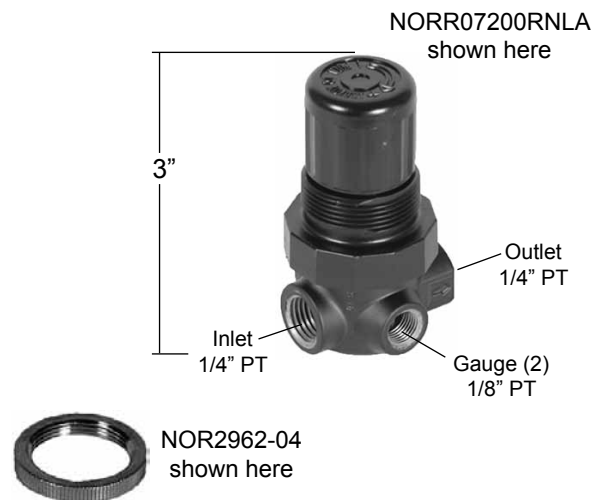

Section 6 • Soupapes de suspension à air • Suspension Air Valves

Manomètres Gauges



New	Notes
FS-6583S	* 2-1/2" Dia. x 1/4" PT Bottom mount. * Silicone liquid filled; Stainless Steel. * reads: 0 to 160 PSI.
Replaces: Ride-Air RA325BL Tectran 27-ADB-15	



New	Notes
FS-6584	* 1-5/8" Dia. x 1/8" PT Bottom mount. * reads: 0 to 160 PSI.



New	Notes
FS-6848S	* 2-1/2" Dia. x 1/4" PT Center mount. * Silicone liquid filled; Stainless Steel. * reads: 0 to 160 PSI.
Replaces: Ride-Air RA325CL	



New	Notes
FS-6849	* 1-5/8" Dia. x 1/8" PT Center mount. * reads: 0 to 160 PSI.
Replaces: Ride-Air RA315C	

Section 6 • Soupapes de suspension à air • Suspension Air Valves

Boîtes pour les contrôles de suspension Air Suspension Control Boxes



New	Notes
	* Air Control Box, Empty. * 12" Square, 6-1/2" Deep.
FS-6967-1	* 18 Gauge, Black Powder Coated Steel. * 8 Pre-punched Access Holes.
FS-6967-1NH	* 18 Gauge, Black Powder Coated Steel. * NO Pre-punched Holes.
FS-6967-1SS	* 304 Stainless Steel - no paint. * 8 Pre-punched access holes * 20 Gauge.
FS-6967-1SSNH	* 304 Stainless Steel - no paint. * NO Pre-punched Holes * 20 Gauge.



All pre-built boxes by FleetSpec include:

- * Plumbing Diagram inside the lid.
- * All components listed for easy ID of replacement parts.
- * Rubber lid seal for improved moisture protection.
- * Rubber Door latch.
- * 100% Factory Tested for reliability.

Section 6 : Soupapes de suspension à air : Suspension Air Valves

Boite de contrôle de suspension à air pour essieu relevable (12x12 po.) Air Suspension Standard 12 x 12 inch Lift Axle Control Boxes

FS-6967-1B (With Norgren style Control Valve)

- * Controls the lifting and lowering of the Lift Axle.
- * With the Regulator, you can adjust the Air Ride pressure to the Lift Axle, to control your loads weight distribution.
- * Silicone filled, Stainless Steel pressure gauge, 0-160 PSI.

Replaces: Manac 021-7181, Ride-Air RA012B

FS-6967-1BSS Same as above, in a Stainless Steel Box.

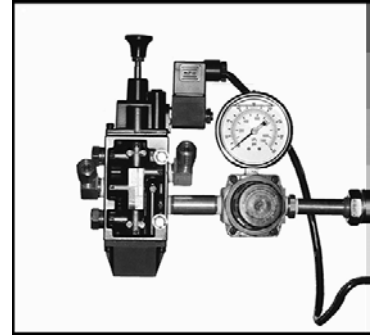

FS-6967-1C (With Norgren style Control Valve)

- * Controls the lifting and lowering of the Lift Axle.
- * With the Regulator, you can adjust the Air Ride pressure to the Lift Axle, to control your loads weight distribution.
- * Silicone filled, Stainless Steel pressure gauge, 0-160 PSI.
- * Lockout Valve eliminates tire damage when the lift axle is up (Lift Axle wheels turn freely).

Replaces: Ride-Air RA012TSR, Tectran 27-ACB-6

FS-6967-1CSS Same as above, in a Stainless Steel box.

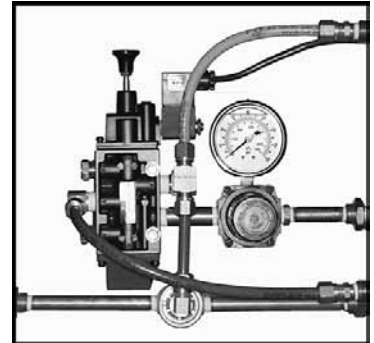

FS-6967-1E (With Ride-Air style Control Valve)

- * Controls the lifting and lowering of the Lift Axle.
- * With the Regulator, you can adjust the Air Ride pressure to the Lift Axle, to control your loads weight distribution.
- * Lockout Valve eliminates tire damage when the lift axle is up (Lift Axle wheels turn freely).
- * Silicone filled, Stainless Steel pressure gauge, 0-160 PSI.

Replaces: Ride-Air RA012, Tectran 27-ACB-6

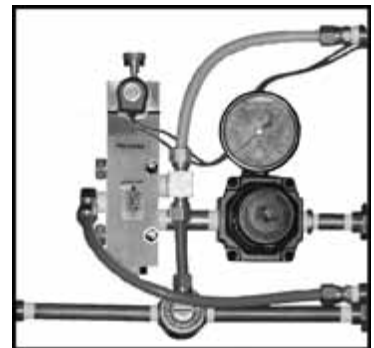

FS-6967-1L (With Schrader style Control Valve)

- * Controls the lifting and lowering of the Lift Axle.
- * With the Regulator, you can adjust the Air Ride pressure to the Lift Axle, to control your loads weight distribution.
- * Silicone filled, Stainless Steel pressure gauge, 0-160 PSI.
- * Lockout Valve eliminates tire damage when the lift axle is up (Lift Axle wheels turn freely).

Replaces: Ride-Air RA012TSR-SWP, Tectran 27-ACB-5

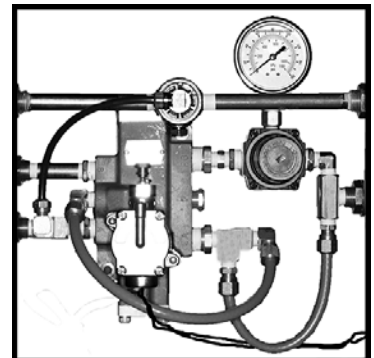

Section 6 • Soupapes de suspension à air • Suspension Air Valves

Boîtes de contrôle pour essieu relevable et d'évacuation de l'air de la suspension pneumatique (12x12po.)

Air Suspension Standard 12 x 12 inch Lift Axle & Air Suspension Dump Control Boxes

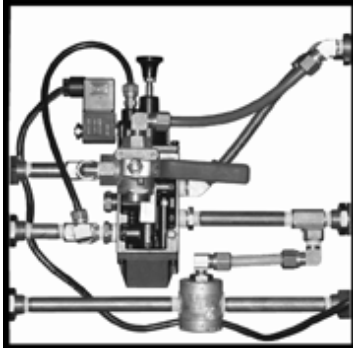

FS-6967-1A (With Norgren style Control Valve)

- * Controls the lifting and lowering of the Lift Axle, and Ride Bags system dump.
- * The Suspension Height Control Valve controls the Air Ride pressure for all axles, including the Lift Axle.
- * Lockout Valve (A) eliminates tire damage when the lift axle is up (Lift Axle wheels turn freely).

Replaces: Ride-Air RA013S, Tectran 27-ACB-8

FS-6967-1ASS Same as above, in a Stainless Steel Box.

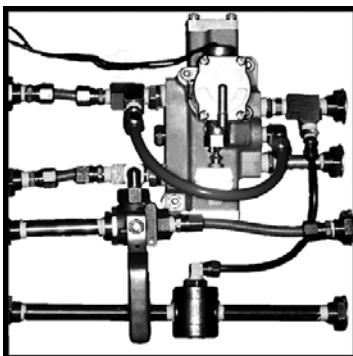

FS-6967-1K (With Schrader style Control Valve)

- * Controls the lifting and lowering of the Lift Axle, and Ride Bags system dump.
- * The Suspension Height Control Valve controls the Air Ride pressure for all axles, including the Lift Axle.
- * Lockout Valve (A) eliminates tire damage when the lift axle is up (Lift Axle wheels turn freely).

Replaces: Tectran 27-ACB-2

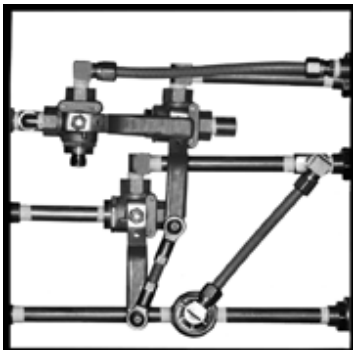

FS-6967-1AM

- * Controls the lifting and lowering of the Lift Axle, and Ride Bags system dump.
- * **Full MANUAL operation**
- * The Suspension Height Control Valve controls the Air Ride pressure for all axles, including the Lift Axle.
- * Lockout Valve eliminates tire damage when the lift axle is up (Lift Axle wheels turn freely).

Section 6 • Soupapes de suspension à air • Suspension Air Valves

Boîtes de contrôle pour essieu relevable autovireur Liftable Steer Axle Control Boxes

FS-6967-1FSS (With Schrader style Control Valve)
* Stainless Steel 12x12 Box

- * With Auto Torpress Regulator.
- * Minimum pre-set regulator @ 25 PSI.
- * Lockout Valve eliminates tire damage when the lift axle is up (Lift Axle wheels turn freely).
- * Suspension Height Control Valve controls the air ride pressure for ALL axles, including the liftable Steer Axle.

Replaces: Ride-Air RA016SRP-31

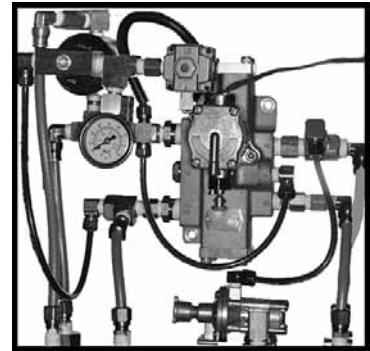

FS-6967-1J (With Ride-Air style Control Valve)

- * With Auto Torpress Regulator.
- * Minimum pre-set regulator @ 25 PSI.
- * Lockout Valve eliminates tire damage when the lift axle is up (Lift Axle wheels turn freely).
- * Suspension Height Control Valve controls the air ride pressure for ALL axles, including the liftable Steer Axle.

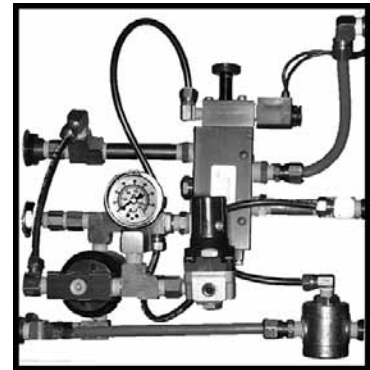

Section 6 · Soupapes de suspension à air · Suspension Air Valves

Boîtes de contrôle pour essieu relevable autovireur, et d'évacuation de l'air Liftable Steer Axle Control Boxes with Dump Control

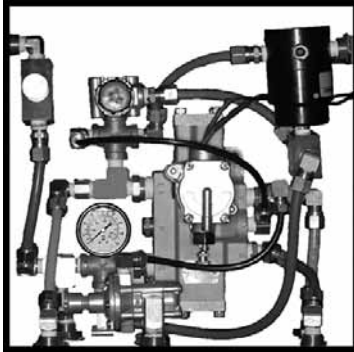

FS-6967-1G (With Schrader style Control Valve)

- * With Auto Torpress Regulator.
- * Minimum pre-set regulator @ 25 PSI.
- * Manual valve to dump & reload air from Primary & Steer Axle Air Springs
- * Lockout Valve eliminates tire damage when the lift axle is up (Lift Axle wheels turn freely).
- * Suspension Height Control Valve controls the air ride pressure for ALL axles, including the liftable Steer Axle.

Replaces: Ride-Air RA016SRP-32

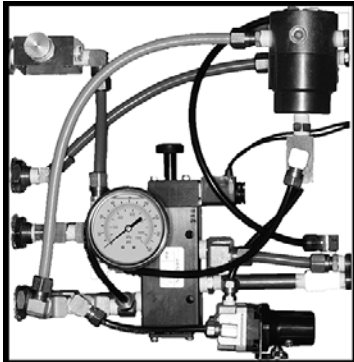

FS-6967-1M (With Ride-Air style Control Valve)

- * With Auto Torpress Regulator.
- * Minimum pre-set regulator @ 25 PSI.
- * Manual valve to dump & reload air from Primary & Steer Axle Air Springs
- * Lockout Valve eliminates tire damage when the lift axle is up (Lift Axle wheels turn freely).
- * Suspension Height Control Valve controls the air ride pressure for ALL axles, including the liftable Steer Axle.

Replaces: Ride-Air RA016SSN-32

Section 6 • Soupapes de suspension à air
 • Suspension Air Valves

Pièces divers
Miscellaneous Parts

New	Notes
FS-6967-1D	* Door Kit for FS-6967-1 (black) Box.
FS-6967-2D	* Door Kit for FS-6967-2 Box.
Kit contains: Door, Hinge Pin, Latch, Cotter Pin, and Pin Mount.	
FS-6967-L	* Latch Kit, fits most Boxes.
Kit contains: Latch, Cotter Pin, and Pin Mount.	
FS-6967-P	* Hinge Pin for FS-6967-1 Box.
FS-6967-1H	* Hinge (with Pin) for FS-6967-1 Box



New	Notes
FS-317E	* Steel Terminal Bolt. * 1/4" Female PT x 1" long.



New	Notes
FS-6970	* 7/8" Grommet, with 3/8" Pass-thru.
FS-6971	* 7/8" Snap-in Hole Plug.



New	Notes
FS-70-2120	* Breather Fitting, 1/8" PT
FS-70-2140	* Breather Fitting, 1/4" PT
FS-70-2160	* Breather Fitting, 3/8" PT



New	Notes
FS-6967-W	Replacement plastic WINDOW for FS-6967-2AW boxes.

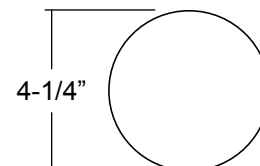

Section 6 . Soupapes de suspension à air . Suspension Air Valves

Boîtes pour les contrôles de suspension Clear Cover Suspension Control Boxes



New	Notes
FS-6967-6	6" square, 3-1/2" deep.
FS-6967-7	8" wide, 10-1/2" tall, 6" deep.
Composite construction, with clear covers, and rubber door seals - Very rugged design.	



Boîtes de contrôle d'évacuation de l'air de la suspension pneumatique Air Suspension Dump Control Boxes



- > Rugged all weather, light weight compact composite box, with Weather Seal.
- > **Minimum** parts, for **Maximum** reliability
- > *Easy to install*, with Push-To-Connect fittings

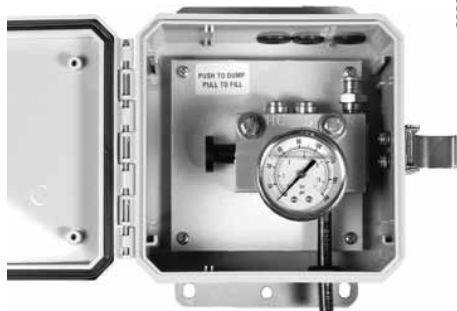

New	Notes
FS-6967-6A	* Durable composite construction. * 6-1/2" square, 4" deep * Manual operation, with Air Reset
Reset port ties into Parking Brake. When Parking Brakes are released, dump valve resets and air flows freely from Height Control Valve to Air Springs.	

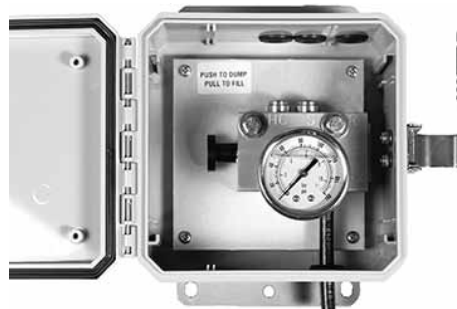

New	Notes
FS-6967-6B	* Durable composite construction. * 6-1/2" square, 4" deep * Full Manual operation.

Section 6 : Soupapes de suspension à air
 : Suspension Air Valves

Boîtes pour les contrôles de suspension
Air Suspension Control Boxes

New	Notes
	* Air Control Box, Empty. * 8-1/4" Square, 4-1/4" Deep.
FS-6967-2	* 18 Gauge, Black Powder Coated Steel. * NO Pre-punched Holes.
FS-6967-2F	* 18 Gauge, Black Powder Coated Steel. * 3 Pre-Punched Access Holes.
FS-6967-2SS	* 304 Stainless Steel - no paint * 20 Gauge * NO Pre-punched Holes. Replaces: Ride-Air RA001TS



All pre-built boxes by FleetSpec include:

- * Plumbing Diagram inside the lid.
- * All components listed for easy ID of replacement parts.
- * Rubber lid seal for improved moisture protection.
- * Rubber Door latch.
- * 100% Factory Tested for reliability.



Section 6 • Soupapes de suspension à air • Suspension Air Valves

Boîtes de contrôle d'évacuation de l'air de suspension pneumatique (8-1/4 x 8-1/4 po.) Air Suspension 8-1/4 x 8-1/4 inch Dump Control Boxes

- * Used to manually exhaust the Air Ride Suspension while the trailer is docked.
- * 3-Way Hand Control Diverter Valve.
- * Silicone filled, Stainless Steel pressure gauge, 0-160 PSI
- * Gauge indicates air pressure in the suspension, which can be used in calculating the load weight.

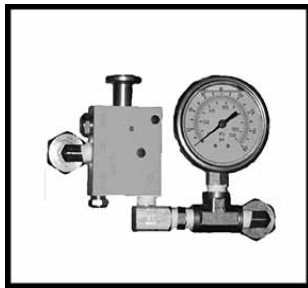

FS-6967-2E

- * 3-Way Push-Pull Diverter Valve.

Replaces: Ride Air RA015GL

FS-6967-2ESS Same as above, in a Stainless Steel Box
 Replaces: Ride-Air RA015LS

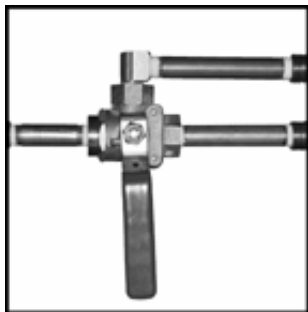

FS-6967-2B

- * Used to manually exhaust the Air Ride Suspension while the trailer is docked.
- * 3-Way Hand Control Diverter Valve.

Replaces: Ride-Air RA014, Tectran 27-ADB-12

FS-6967-2BSS Same as above, in a Stainless Steel Box

Replaces: Tectran 27-ADB-16



FS-6967-2C

- * Used to electrically exhaust the Air Ride Suspension while the trailer is docked.
- * 3-Way Electric Solenoid Valve.

Section 6 : Soupapes de suspension à air
 : Suspension Air Valves

Boîtes pour les contrôles de suspension
Air Suspension Control Boxes

FS-6967-2A

Replaces: Meritor R986058
 Ride Air RA014GL
 Tectran 27-ADB-15, 27-ADB-66

FS-6967-2ASS Same as above, in a Stainless Steel Box
 Replaces: Ride-Air RA014GLS

FS-6967-2AW Same as above, in a standard box with a window for easy viewing of the pressure gauge.

FS-6967-2ASSW Same as above, in a Stainless Steel Box with a window for easy viewing of the pressure gauge.

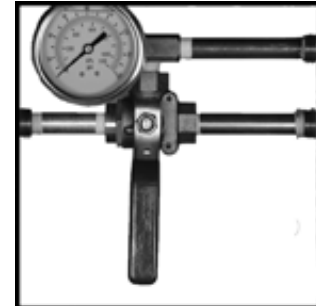

FS-6967-2AW shown here

New	Notes
FS-6967-3	* Air Control Box, Empty. * Black Powder Coated Steel. * 10" High, 18" Long, 6" Deep.



New	Notes
FS-6967-3D	* Door Kit for FS-6967-3 * Foam Seal included. * Latch & Cotter Pin included.



Section 6 . Soupapes de suspension à air . Suspension Air Valves

Boîtes pour les contrôles de suspension Air Suspension Control Boxes



New	Notes
FS-6967-4	* Air Control Box, Empty. * Black High-Gloss Painted Steel. * Foam Door Seal included. * 10" High, 12" Wide, 6" Deep.
Replaces: Manac 482-9041	



New	Notes
FS-6967-4D	* Door for FS-6967-4 Box. * Foam Seal included. * Latch & Cotter Pin included.
Replaces: Manac 582-90411	



New	Notes
FS-6967-5	* Air Control Box, Empty. * Black Powder Coated 18 Ga. Steel. * Foam Door Seal included. * 10" High, 18" Wide, 6" Deep.
Replaces: Manac 223-354	



New	Notes
FS-6967-5D	* Door for FS-6967-5 Box. * Foam Seal included.
Replaces: Manac 492-910	
FS-6967-5L	* Latch Kit for FS-6967-5 Box



Section 6 : Soupapes de suspension à air
 : Suspension Air Valves

Boîtes de contrôle pour essieu auto-vireur relevable, avec contrôle de vidange d'air
Liftable Steer Axle Control Boxes, with Dump Control

New	Notes
FS-6967-5A	<ul style="list-style-type: none"> * Steerable Lift Axle MUST be lifted (Up position) when backing up. * Controls the lifting and lowering of the Lift Axle, and Ride Bags system dump. * Suspension Height Control Valve controls Air Ride Pressure for ALL axles, including the Lift Axle. * Lockout Valve (A) eliminates tire damage when the Lift Axle is up. (Lift Axle Wheels turn freely) * Silicone filled, Stainless Steel Pressure Gauge, 0 to 160 PSI. * REQUIRES Control Box FS-6967-8A to control the Torpress Air Bag.
Replaces: Manac 072-0561	

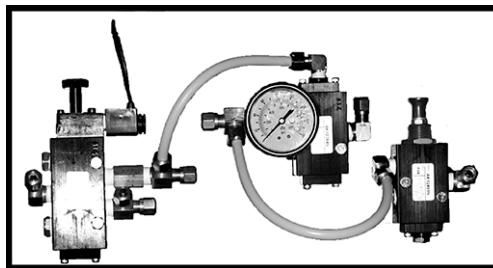

New	Notes
FS-6967-5B	<ul style="list-style-type: none"> * Controls the lifting and lowering of the Lift Axle, and Ride Bags system dump. * Suspension Height Control Valve controls Air Ride Pressure for ALL axles, including the Lift Axle. * For Reverse Operation (Backing up), the Self-Steering Axle MUST be lifted. This activates the Locking Cylinder automatically. (Prevents Self-Steer Axle wheels from turning) * Lockout Valve (A) eliminates tire damage when the Lift Axle is up. (Lift Axle Wheels turn freely) * Silicone filled, Stainless Steel Pressure Gauge, 0 to 160 PSI. * REQUIRES Control Box FS-6967-8A to control the Torpress Air Bag.

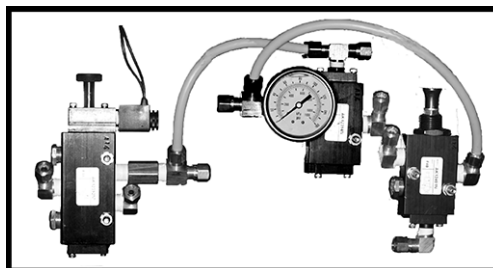

Section 6 . Soupapes de suspension à air . Suspension Air Valves

Boîtes pour les contrôles de suspension Air Suspension Control Boxes



Back
view

New	Notes
FS-6967-8	* Air Control Box, Empty. * Black Powder Coated Steel. * Foam Door Seal included. * 8-1/4" Square, 4-1/2" Deep.
Replaces: Manac 223-352	

Boîtes de contrôle pour essieu relevable autovireur, Lifiable Steer Axle Torpress Air Bag Control Box (8-1/4" square)

New	Notes
FS-6967-8A	* With the Regulator, you can adjust the Air Ride Pressure to the Self-Steering Lift Axle Torpress Air Bag, to control the drivability of the self-steering axle. * Silicone Filled, Stainless Steel Gauge, 0 to 160 PSI.



